

PRODUCT: SPJ-PCL-UL-B

WEIGHT: 20 lbs.

QUANTITY: \_\_\_\_

CONCRETE COLOR:

- COAST
- CONCRETE
- CARBON
- CLAY
- BARK

CONCRETE TEXTURE:

- ETCHED
- POLISHED

LIGHT ENGINE:

- 2W 125 LUMENS
- 8W 300 LUMENS
- 8W 580 LUMENS
- 16W 1,000 LUMENS

SEALER: STD. SEALER 4200



GENERAL PRODUCT NOTES:

E = EXPOSED FINISHED SURFACE

INSTALLATION IS REQUIRED BY OTHERS.

ALL EDGES TO BE EASED.

MANUFACTURING TOLERANCE ±1/4".

2700K STANDARD ELECTRICAL TEMPERATURE: 8-15V

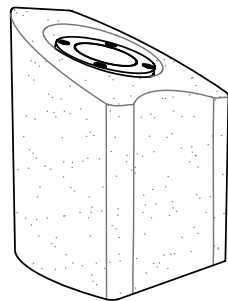

PERSPECTIVE VIEW

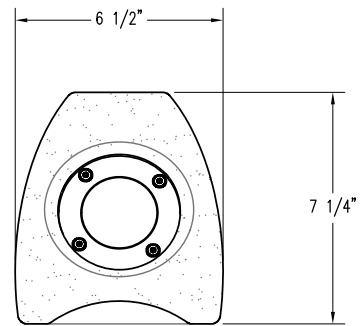

PLAN VIEW

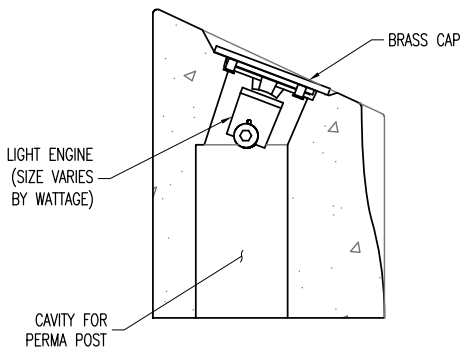

SECTION VIEW

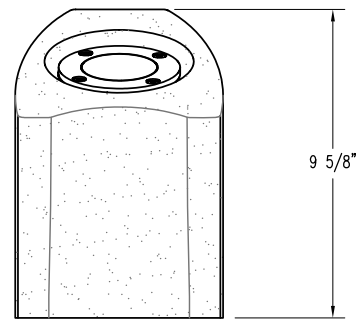

ELEVATION VIEW



Wet Listed



**SPJ** LIGHTING Inc.  
ARCHITECTURAL LANDSCAPE & OUTDOOR LIGHTING

PLAN TYPE	CONSTRUCTION PLAN	DATE	11/3/20	FILE NO.	010_ST-UL-B	SHEET	1
PRODUCT	SPJ-PCL-UL-B   UPLIGHT	SCALE	2" = 1'	DRAWN BY:	W.R.	OF	2
PROJECT NAME		PC. NO.		QC ITEM NO.			

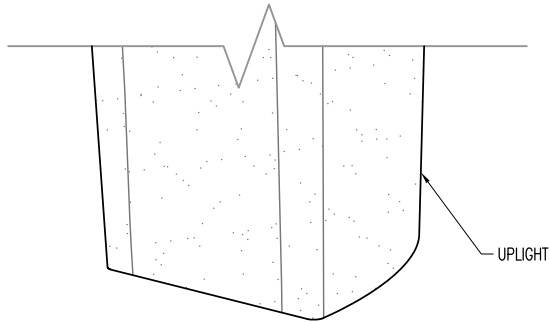

UPLIGHT

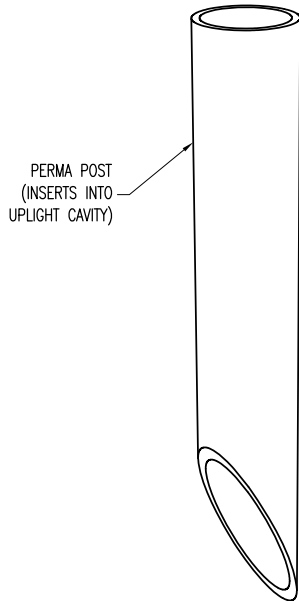

PERMA POST  
(INSERTS INTO  
UPLIGHT CAVITY)

PERSPECTIVE VIEW  
N.T.S.

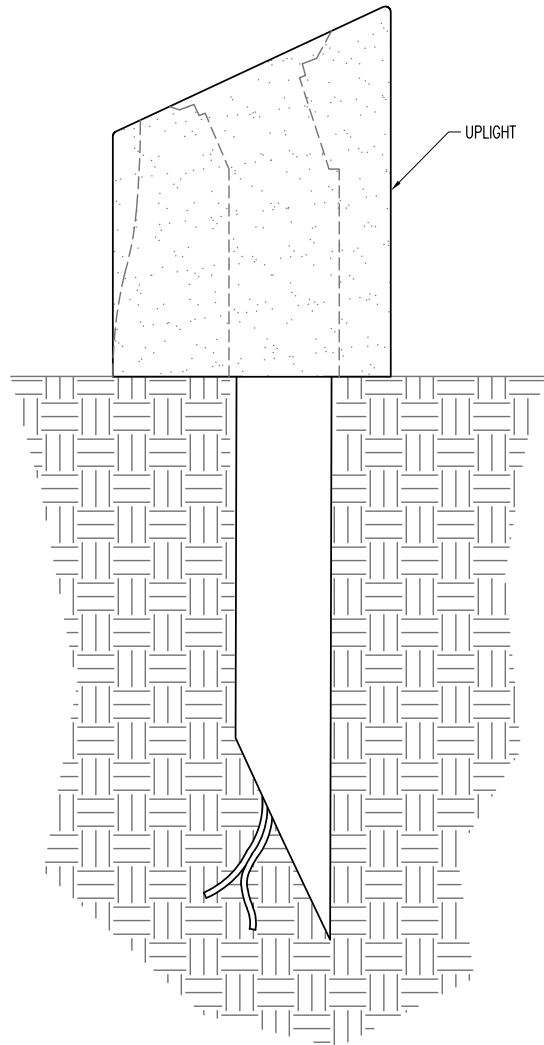

UPLIGHT

INSTALLATION SIDE VIEW  
N.T.S.



Wet Listed



 ARCHITECTURAL LANDSCAPE & OUTDOOR LIGHTING	PLAN TYPE	INSTALLATION PLAN	DATE	FILE NO.	SHEET
	PRODUCT	SPJ-PCL-UL-B   UPLIGHT   IN GROUND	11/3/20	010a_ST-UL-B-IG	2
	PROJECT NAME		SCALE	DRAWN BY:	OF
			3" = 1'	W.R.	2
			PC. NO.	QC ITEM NO.	