

SPJ15-04

Wash Light

Quick Ship

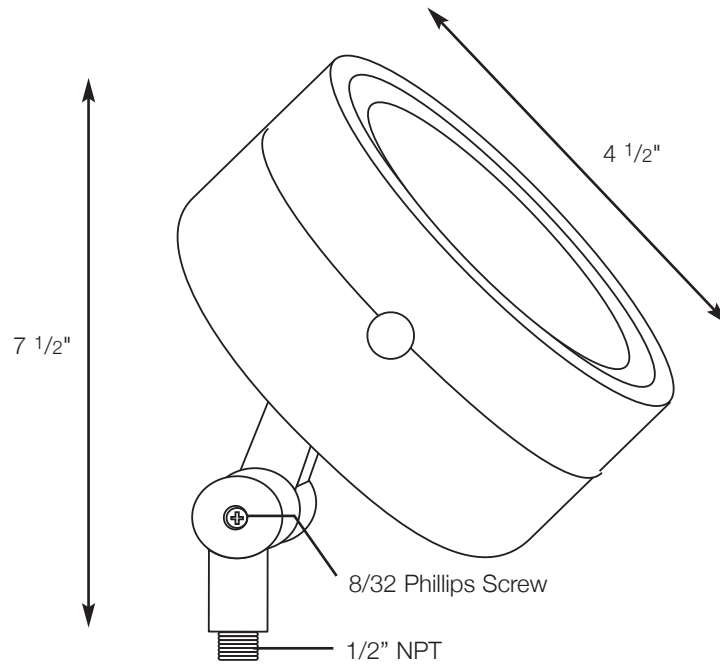

MODEL: SPJ15-04
MATERIAL : Solid Brass
FINISH : Specify
ELECTRICAL : 12v
SOCKET : Single Contact Bayonet
LAMP : 13W S.C.B or 20W Bi-Pin
MOUNTING : 1/2" NPT Dual Fin Spike Incl.

DRAWN BY: MMC

BASE DESIGN: SPJ

DATE: 01-10-10

SPJ LIGHTING INC.

2107 Chico Avenue
 South El Monte, CA 91733
 (800) 469-3637 FAX: (626) 433-4839