



Forever Bright

SPECIFICATION FEATURES



Model: **SPJ13-300**
Finish: Matte Bronze

- Finish:** Our naturally etched finishes will withstand the test of time. All finishes are individually treated insuring consistency. Our meticulous application results in a fixture that truly becomes "a one of a kind".
- Electrical:** Available in 8-15V
- Labels:** ETL Standard Wet Label
C-ETL

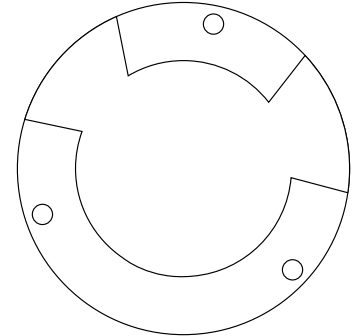

360° Light Distribution

Marker Light

DESCRIPTION

- Model#:** SPJ13-300
- Material:** Cast Brass
- Electrical:** 8-15V
- Engine:** FB-3W-CYL-TA16
- Lumens:** 150
- Color Temp:** 2700K
- Mounting:** In-Ground
- Key Spec:** Clear tempered refractor lens w/gasket
- LED:** Nichia

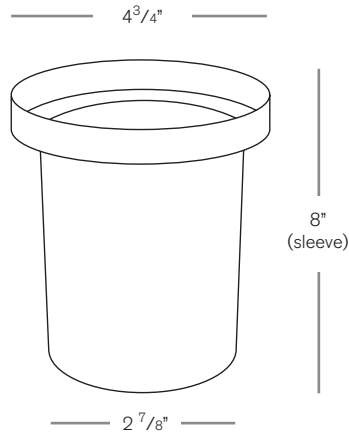

Brass Pour Sleeve

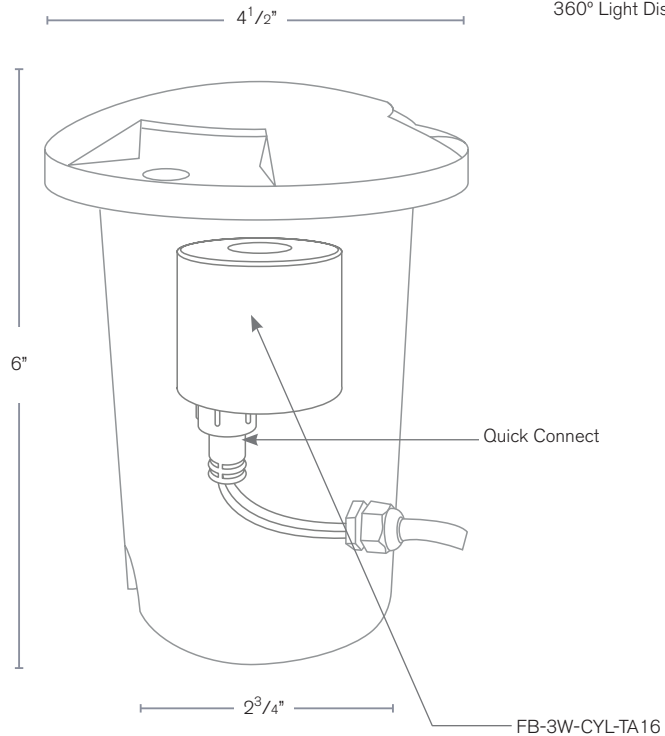

Wet Listed



ORDERING INFORMATION

Model#	Finishes	Wattage	Lumens	Color Temp.	Electrical
SPJ13-300	MBR	3W	150	2700K	8-15V

V = Verde	GM = Gun Metal	1W	50	2700K	8-15V
M = Moss	B = Black	2W	135	4000K	
AG = Aged Brass	R = Rusty	3W	150	5000K	
MBR = Matte Bronze	PVDP = PVD Polished	6W	300		
SB = Satin Brass	PVDS = PVD Satin	8W	580		