



# Forever Bright

## SPECIFICATION FEATURES



Model: **SPJ105-B**  
Finish: Custom Powder Coat

- Finish:** Our naturally etched finishes will withstand the test of time. All finishes are individually treated insuring consistency. Our meticulous application results in a fixture that truly becomes "a one of a kind".
- Electrical:** Available in 9-15V or 220V
- Labels:** ETL Standard Wet Label  
C-ETL

**Higher Lumen Packages Available  
Consult Customer Service**

### Contemporary Path Light

#### DESCRIPTION

- Model#:** SPJ105-B
- Material:** Aluminum
- Electrical:** 12V, 120V or 220V
- Engine:** 4.5W Sandwich (standard)
- Lumens:** 250
- Color Temp:** 2700k
- Mounting:** Deck Mount
- LED:** Nichia

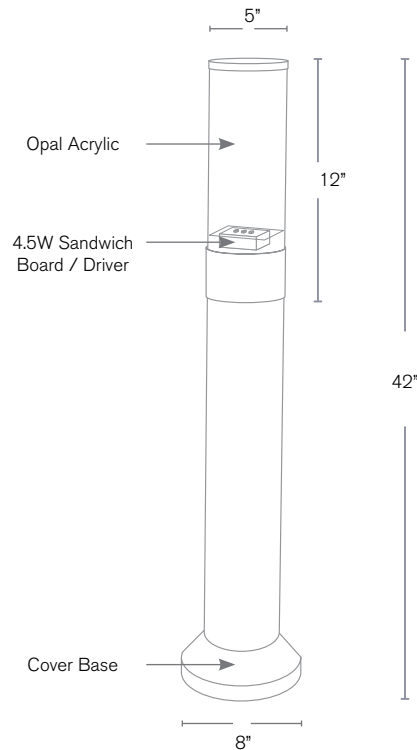

**Wet Listed**



#### ORDERING INFORMATION

Model#	Finishes	Wattage	Lumens	Color Temp.	Electrical
<b>SPJ105-B</b>	<b>Powdercoat</b>	<b>4.5W</b>	<b>250</b>	<b>2700K</b>	<b>12V</b>
		4.5W	250	2700K 4000K 6500K	12V 120V 220V