

SPJ05-02

Garden Lantern

Shown: T-Bar Overlay

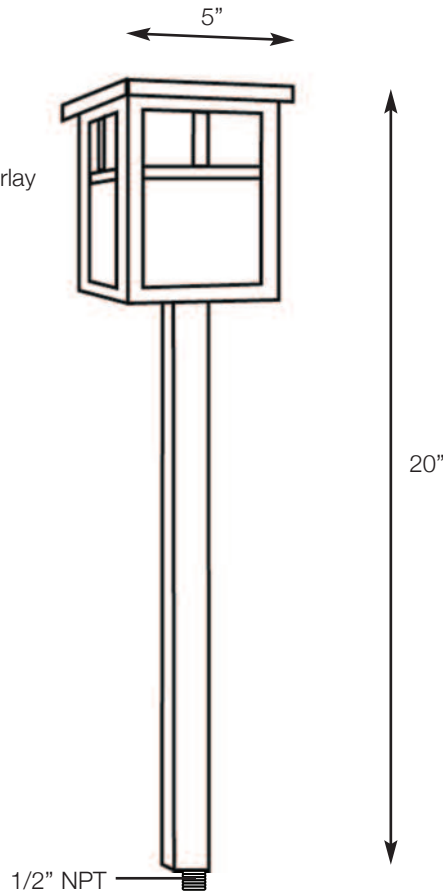

- MODEL:** SPJ05-02
- MATERIAL :** Solid Brass
- FINISH :** Specify
- GLASS :** Specify
- ELECTRICAL :** 12v or 120v
- SOCKET :** Single Contact Bayonet
- LAMP :** 26w Max.
- MOUNTING :** 1/2" NPT Dual Fin Spike Incl.
- OVERLAY :** Specify

Unlimited LED Lumen Packages & Color Temperatures Available!



SPJ-A19
12V
2W or 4W

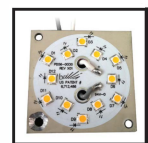

FB-MP1000
120V
10W
1000 LUMENS
WARM DIMMING

DRAWN BY: MMC

BASE DESIGN: SPJ

DATE: 01-10-10

SPJ LIGHTING INC.

2107 Chico Avenue
South El Monte, CA 91733
(800) 469-3637 FAX: (626) 433-4839