

SPJ05-01

Garden Lantern

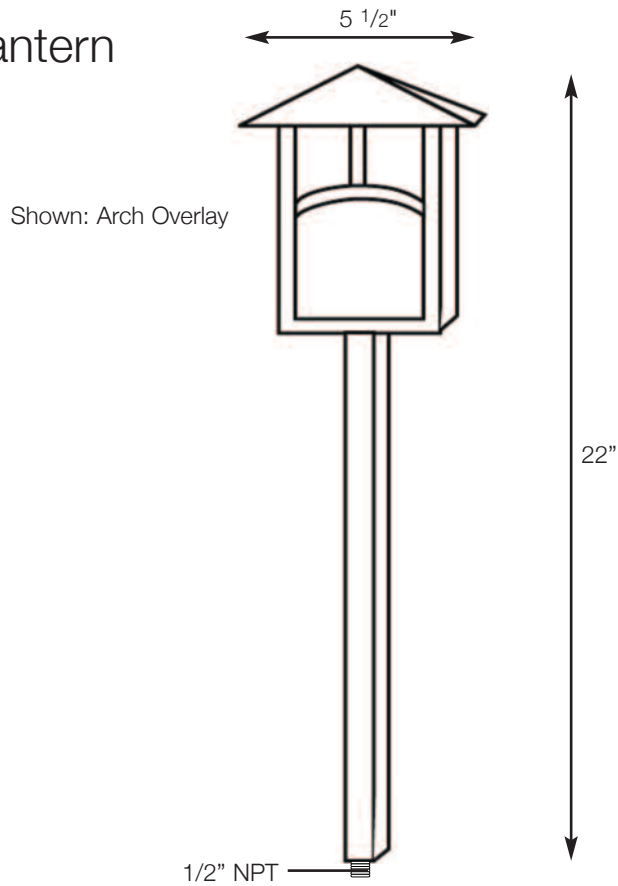

- MODEL:** SPJ05-01
- MATERIAL :** Solid Brass
- FINISH :** Specify
- GLASS :** Specify
- ELECTRICAL :** 12v or 120v
- SOCKET :** Single Contact Bayonet
- LAMP :** 26w Max.
- MOUNTING :** 1/2" NPT Dual Fin Spike Incl.
- OVERLAY :** Specify

*Unlimited LED Lumen
Packages & Color
Temperatures Available!*



SPJ-2W-CB-C
2W
12V or 120V

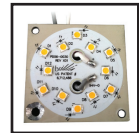

FB-MP1000
120V
10W
1000 LUMENS
WARM DIMMING

DRAWN BY: MMC

BASE DESIGN: SPJ

DATE: 01-10-10

SPJ LIGHTING INC.

2107 Chico Avenue
South El Monte, CA 91733
(800) 469-3637 FAX: (626) 433-4839