



MODEL: **SPJ-HMU-3**  
 FINISH: **Verde**  
 ELECTRICAL: **8-15V**  
 ENGINE: **FB-3W-CYL-TA16**  
 LUMENS: **200**  
 MOUNTING: **Hanging**  
 LED: **Nichia**

**FINISHES**

- Matte Bronze (MBR)
- Verde (V)
- Moss (M)
- Black (B)
- Rusty (R)
- Satin Brass (SB)
- Aged Brass (AG)
- Raw Copper (RC)
- Natural Copper (NC)

**PVD PREMIUM**

- PVD Polished (PVDP)
- PVD Satin (PVDS)
- PVD Graphite (PVDG)
- PVD Bronze (PVDBZ)
- PVD Black (PVDBL)

WATTAGE	LUMENS
<input type="checkbox"/> 1W	80
<input type="checkbox"/> 2W	150
<input type="checkbox"/> 3W	200
<input type="checkbox"/> 6W	300

Custom lumen packages are available upon request

**COLOR TEMPERATURE**

- 2200K
- 2700K
- 3000K
- 4000K
- 5000K
- 6500K
- RGBW

Custom options are available

**ELECTRICAL**

- 8-15V

**OPTICS**

- SPOT 19d
- FLOOD 38d
- WIDE FLOOD 54d
- WIDE ANGLE FLOOD 120d

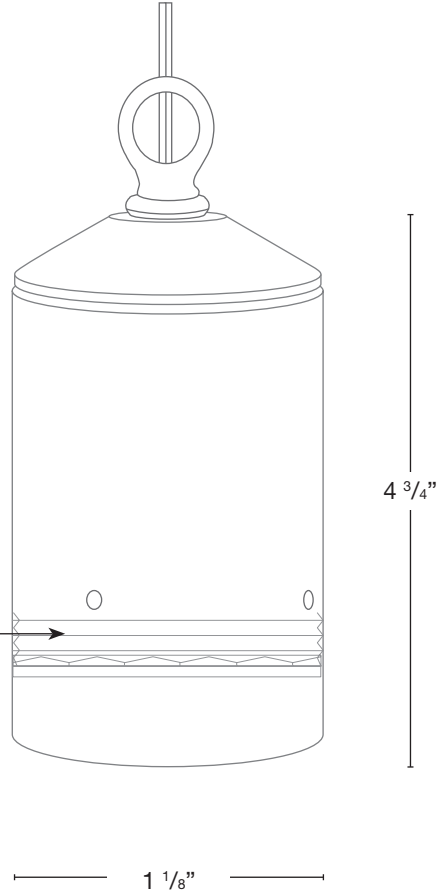

**MOUNTING CANOPIES**

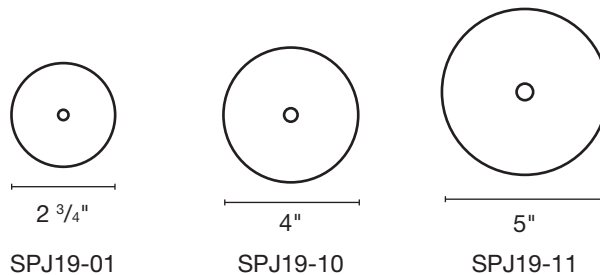

Wet Listed



Ordering Example	Customer Approval	Date
SPJ-HSN-3-V-3W-27K-8-15V		