

PRODUCT: SPJ-PCL-B20-IG

WEIGHT: 15 lbs.



Wet Listed



CONCRETE COLOR:

- COAST
- CONCRETE
- CARBON
- CLAY
- BARK

CONCRETE TEXTURE:

- ETCHED
- POLISHED

LIGHT ENGINE:

- 2W 125 LUMENS
- 8W 300 LUMENS

QUANTITY: _____

SEALER: STD. SEALER 4200

GENERAL PRODUCT NOTES:

E = EXPOSED FINISHED SURFACE

INSTALLATION IS REQUIRED BY OTHERS.

ALL EDGES TO BE EASED.

MANUFACTURING TOLERANCE $\pm 1/4"$.

2700K STANDARD ELECTRICAL TEMPERATURE: 8-15V

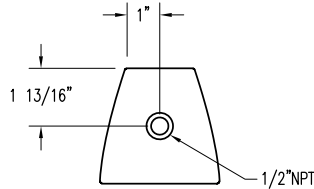

BOTTOM VIEW

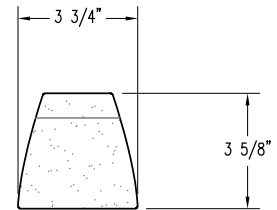

PLAN VIEW

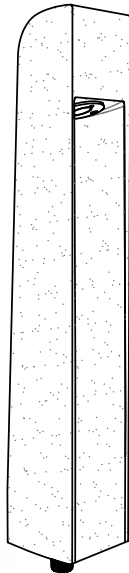

PERSPECTIVE VIEW

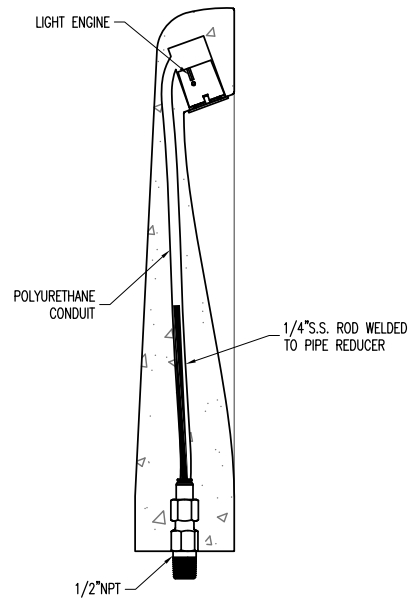

SECTION VIEW

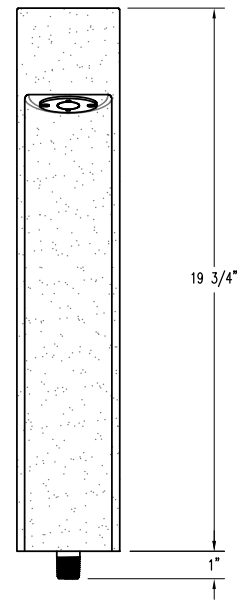

ELEVATION VIEW

SPJ LIGHTING Inc.
ARCHITECTURAL LANDSCAPE & OUTDOOR LIGHTING

PLAN TYPE	CONSTRUCTION PLAN	DATE	11/2/20	FILE NO.	005_ST-PL-B20-IG	SHEET	1
PRODUCT	SPJ-PCL-B20-IG PATHWAY LIGHT SURFACE MOUNT	SCALE	2" = 1'	DRAWN BY:	W.R.	OF	
PROJECT NAME		PC. NO.		QC ITEM NO.			2



Wet Listed

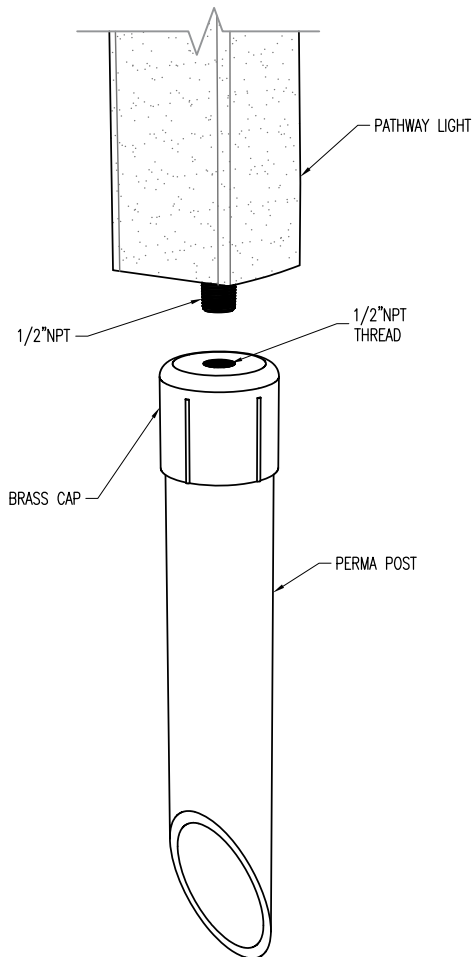

PERSPECTIVE VIEW
N.T.S.

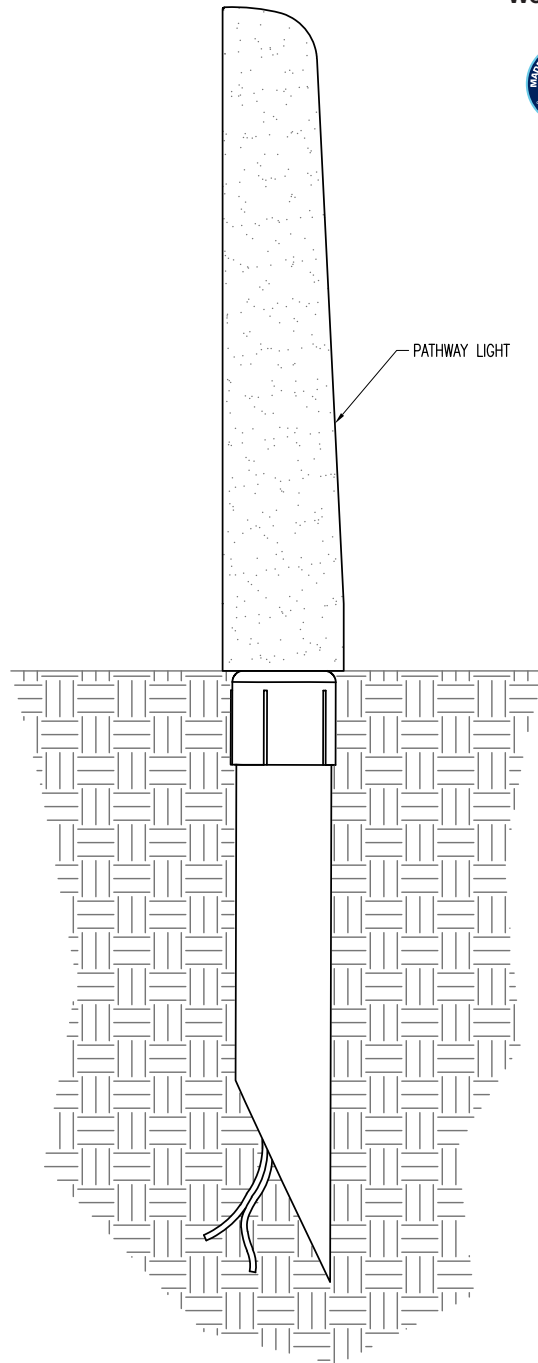

INSTALLATION SIDE VIEW
N.T.S.

<p>ARCHITECTURAL LANDSCAPE & OUTDOOR LIGHTING</p>	PLAN TYPE	INSTALLATION PLAN	DATE	FILE NO.	SHEET
	PRODUCT	SPJ-PCL-B20-IG PATHWAY LIGHT SURFACE MOUNT	11/2/20	005a_ST-PL-B20-IG IN	2
	PROJECT NAME		SCALE	DRAWN BY:	OF
			3" = 1'	W.R.	2
			PC. NO.	QC ITEM NO.	