

PRODUCT: SPJ-PCL-A36-BG

WEIGHT: 126 lbs.



Wet Listed



CONCRETE COLOR:

- COAST
- CONCRETE
- CARBON
- CLAY
- BARK

CONCRETE TEXTURE:

- ETCHED
- POLISHED

QUANTITY: ___

SEALER: STD. SEALER 4200

GENERAL PRODUCT NOTES:

E = EXPOSED FINISHED SURFACE

INSTALLATION IS REQUIRED BY OTHERS.

ALL EDGES TO BE EASED.

MANUFACTURING TOLERANCE $\pm 1/4"$.

2700K STANDARD ELECTRICAL TEMPERATURE: 120-277V

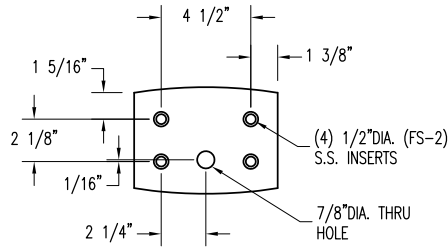

BOTTOM VIEW

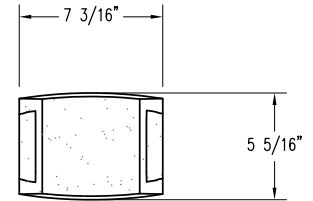

PLAN VIEW



PERSPECTIVE VIEW

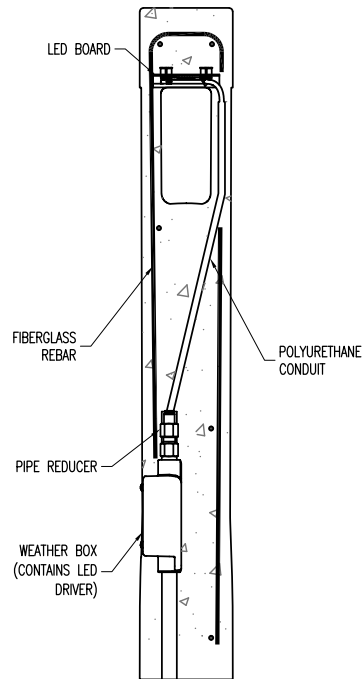

SECTION VIEW

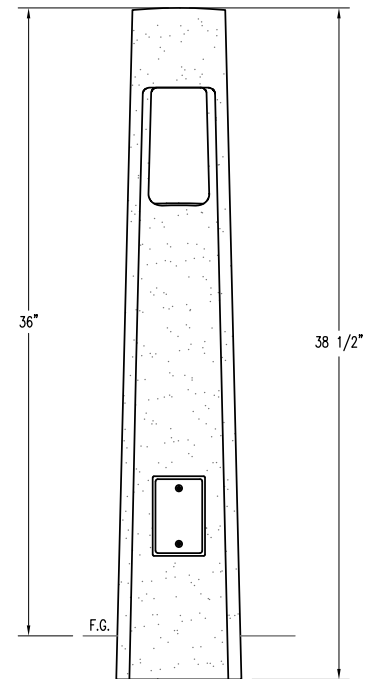

ELEVATION VIEW

SPJ LIGHTING Inc.
ARCHITECTURAL LANDSCAPE & OUTDOOR LIGHTING

PLAN TYPE	CONSTRUCTION PLAN	DATE	11/3/20	FILE NO.	015_ST-BOL-A36-BG	SHEET	1
PRODUCT	SPJ-PCL-A36-BG LIGHTED BOLLARD BELOW GRADE	SCALE	1 1/4" = 1'	DRAWN BY:	W.R.	OF	
PROJECT NAME		PC. NO.		QC ITEM NO.			2



Wet Listed

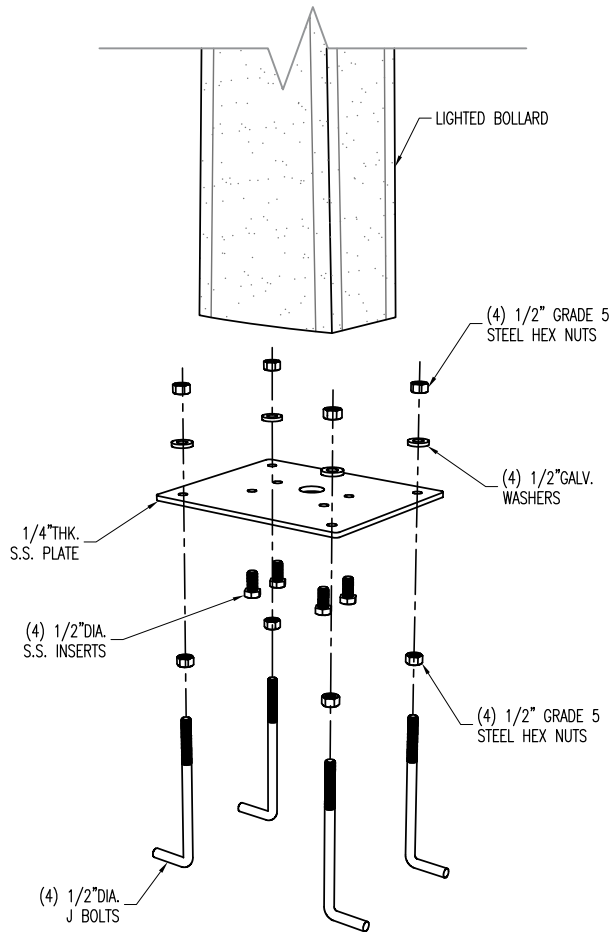

PERSPECTIVE VIEW
N.T.S.

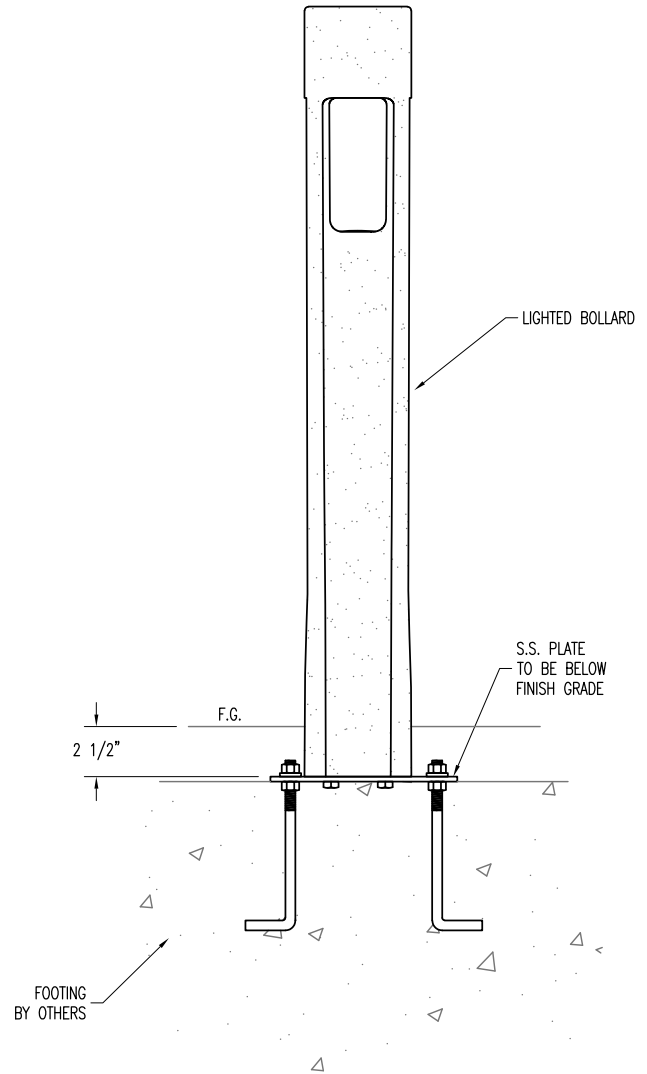

INSTALLATION VIEW
N.T.S.

<p>ARCHITECTURAL LANDSCAPE & OUTDOOR LIGHTING</p>	PLAN TYPE	INSTALLATION VIEW	DATE	FILE NO.	SHEET
	PRODUCT	SPJ-PCL-A36-BG LIGHTED BOLLARD BELOW GRADE	11/3/20 015a_ST-BOL-A36-BG IN	DRAWN BY:	2
	PROJECT NAME		SCALE	W.R.	OF
			1 1/4" = 1'	QC ITEM NO.	2