



ENGWE

User Manual



<https://engwe-bikes-eu.com>
<https://engwe-bikes.com>

L20 2.0

PLEASE READ THIS MANUAL CAREFULLY BEFORE USING YOUR E-BIKE

Preface

Thank you for choosing the ENGWE series of products. In order to familiarize yourself with the use and ensure a safer ride, please read this manual carefully.

1.Before riding, carefully check if all components are in good working order to ensure yoursafety. If any problems are found, please contact the seller in a timely manner.

2.Please comply with the traffic regulations in your local area.Slow down in rainy, snowy and slippery road conditions, and increase braking distance to ensure safety.

3.The vehicle can be ridden in rainy and snowy weather, in order to ensure your safety and prevent damage to the vehicle, please avoid riding through water.if the water depth exceeds the center height of the motor.

4.The vehicle battery is safe but, you should never touch the battery electrodes and the vehicle circuit to avoid the risk of short circuit and injury.

5.It is prohibited to use the vehicle's matching battery to power other electrical appliances as this may cause damage to the battery. Please use the original charger to charge the battery.

6.Do not disassemble or dismantle components , If replacement is needed please purchase standard components from the seller.

7.Please avoid washing the vehicle directly with water. If cleaning is necessary, wipe with cloth.

8.Regularly maintain your brakes, tires, and other movable components to ensure the normal operation of your vehicle.

Table of contents

Preface

1. Vehicle Basic Information	01
1.1 Vehicle Introduction	01
1.2 Vehicle Spece	02
1.3 Use of Product	02
2. Vehicle Assembly Instructions	03
2.1 Vehicle Component ' s	03
2.2 Bolt Size/Tools/Torque Specifications	05
2.3 Vehicle Assembly and Adjustment	05
3. Pre-ride Instructions	11
3.1 Riding Techniques	11
3.2 Pre-ride Preparation	11
4. Display Panel Instructions	12
4.1 Product name and model	12
4.2 Specifications	12
4.3 Appearance and dimensions	12
4.4.Function overview and functional area layout	13
4.5 General operation	14
4.6 General setting	15
5. Battery and Charger	17
5.1 Battery Technical Data and Precautions	17
5.2 Battery Usage Instructions	17
5.3 Battery Storage and Disposal	18
5.4 Charger Technical Data and Precautions	19
6. Common Faults and Maintenance	20
7. Warranty Service	21
8. Disclaimer	24

1. Vehicle Basic Information

1.1 Vehicle Introduction

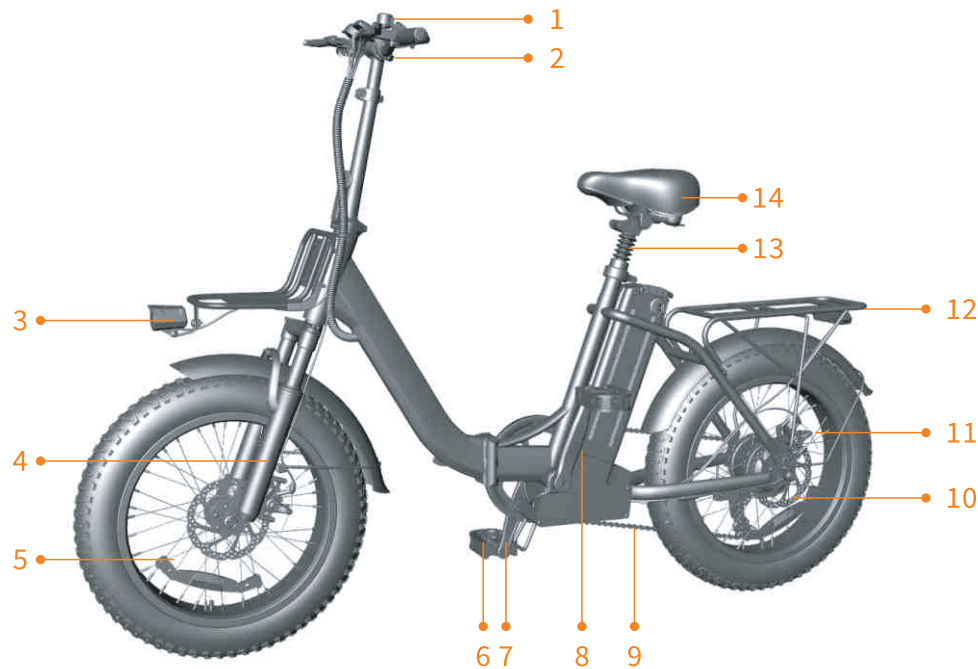

1	Display	8	Battery
2	Handlebar	9	Chain
3	Front light	10	wheel
4	Fork	11	Motor
5	Tire	12	Rear light
6	Pedal	13	Seatpost
7	Crank set	14	Saddle

1.2 Vehicle Specs

Project	Parameters
Model	L20 2.0
Vehicle Dimensions(in)	1700*640*1290MM
Wheel Diameter(in)	20Inches
Frame Mateial	Aluminium alloy
Maximum Load Weight(lb)	264 (120KG)
Vehicle Weight(lb)	68.2 (31KG)
Maximium Speed(MPH)	28(45KM/H)
Rear Derailleur Level	7
Battery Rated Voltage(V)	52
Battery Capacity(AH)	13
Motor Power(W)	750
Charger Input Voltage(AC-V)	100-240
Charger Output Voltage(DC-V)	58.8
Charger Maximum Outout Current(A)	2

1.3 Use of Product

This product is designed specifically for urban commuting, with strong power and long range. Suitable for riding on urban paved roads, flat gravel roads, and improved small roads with moderate slopes and non-slip tires. The rear rack is designed to accommodate objects up to 25 KG. The battery is designed so that it can be easily removed by simply turning the key. High visibility headlights make riding safer at night.

2. Vehicle Assembly Instructions

2.1 Vehicle Component 's

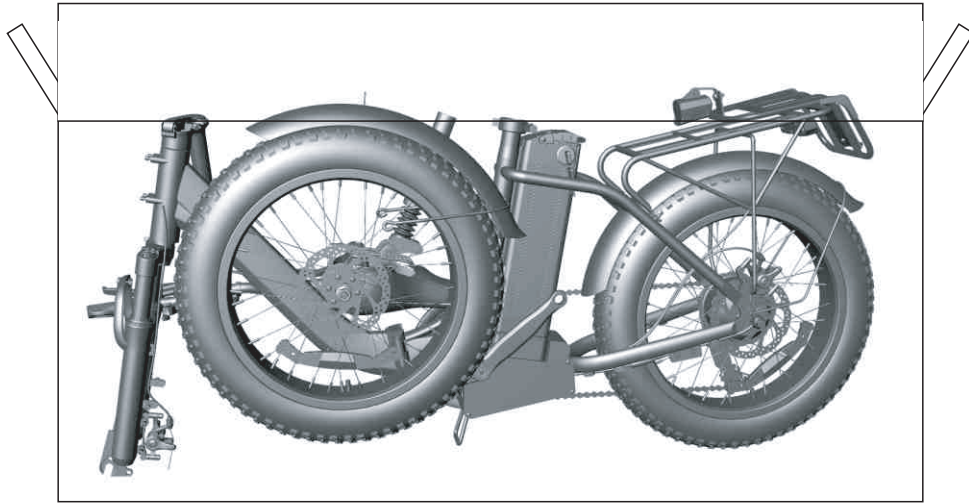

Vehicle Packaging Details

Vehicle Packaging Details		
Outer Shipping	Partially Assembled	Main
	Accessory Box	Instruction Manual
		Tool Kit
		Pedals
		Charger
		Other Accessories

Tool Kit Details

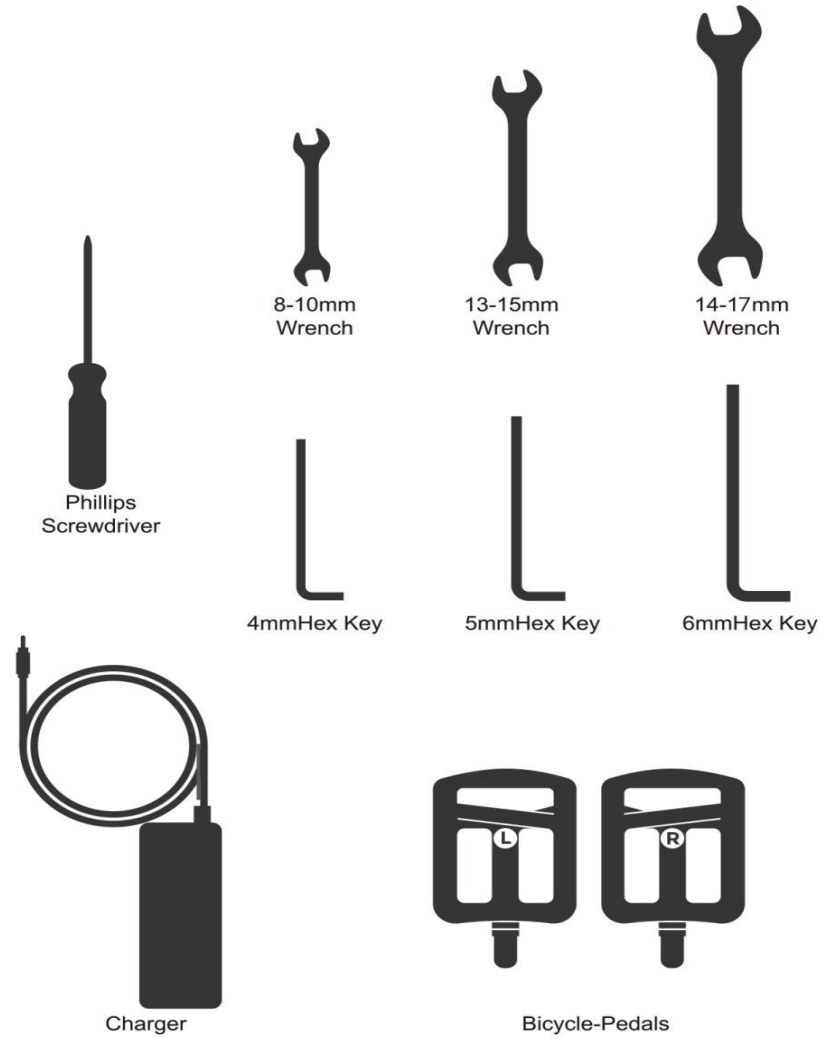

2.2 Bolt Size/Tools/Torque Specifications

Assembly Parts	Tools for Use	Torque Value N.m
Front Axle	8-10mm wrench	20
Handlebar	13-15mm wrench	15
Pedal	14-15mm wrench	20
Crank	4mm Hex Key	15
Rear rack	5mm Hex Key	10
Saddle	6mm Hex Key	6

2.3 Vehicle Assembly and Adjustment

2.3.1 Remove the front wheel.

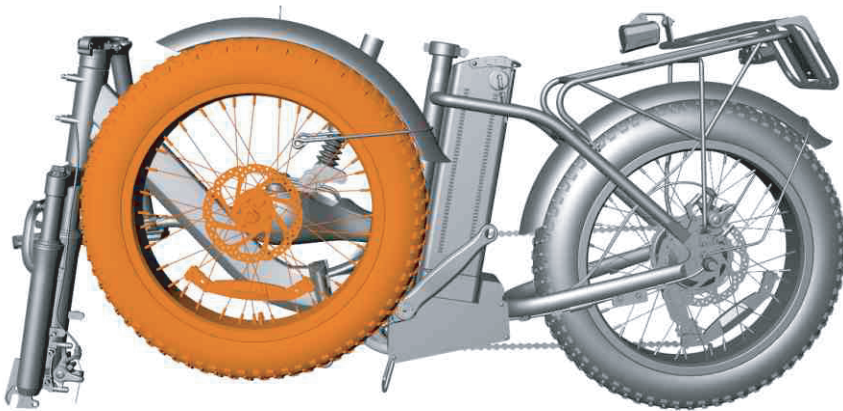

2.3.2 Take off the protective covers on both sides of the front wheel.



2.3.3 Remove the foam wrapped on the handle bars, and then adjust the instrument to the correct position. Arrange the handlebars and use a 5mm hex wrench to rotate clockwise to install two screws. The installation sequence is shown in the following figure. Once the screws and handlebars are in the correct position, tighten the screws and apply appropriate force, Do not overtighten.

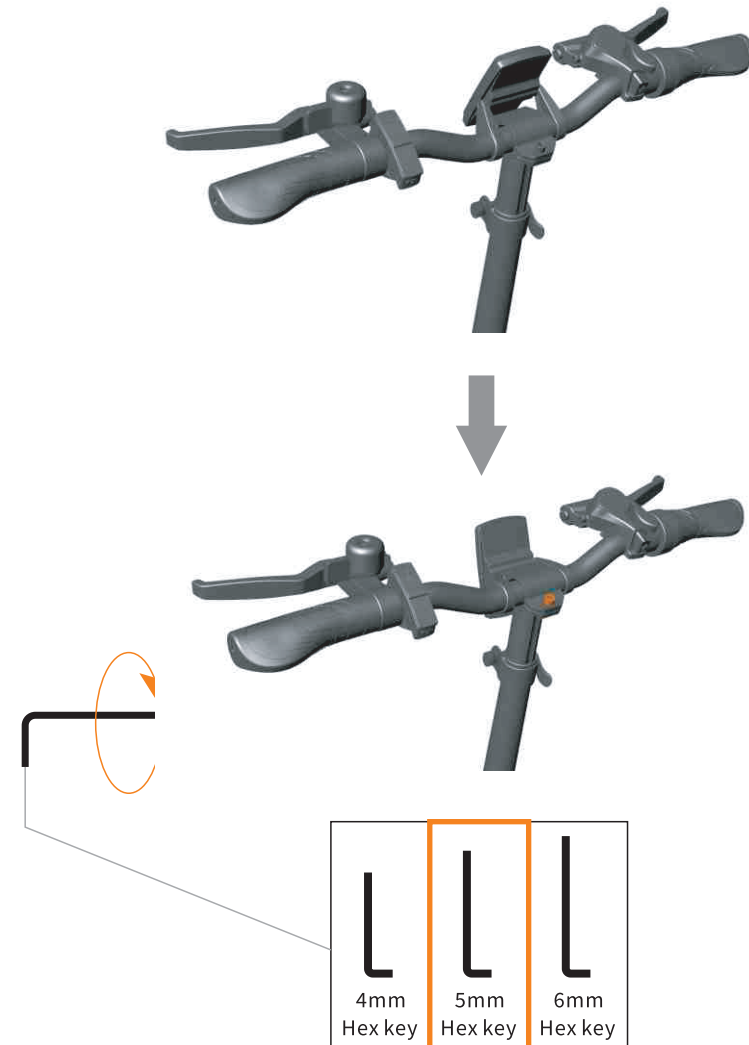

2.3.4 Remove the foam wrapped around the front fender, as shown in the figure below. Align the front fender lug with the front fork installation hole and tighten the screw using a 4mm hex wrench. Align the front fender bracket with the installation hole, as shown in the figure below, and tighten the screw with a 4mm hex wrench.

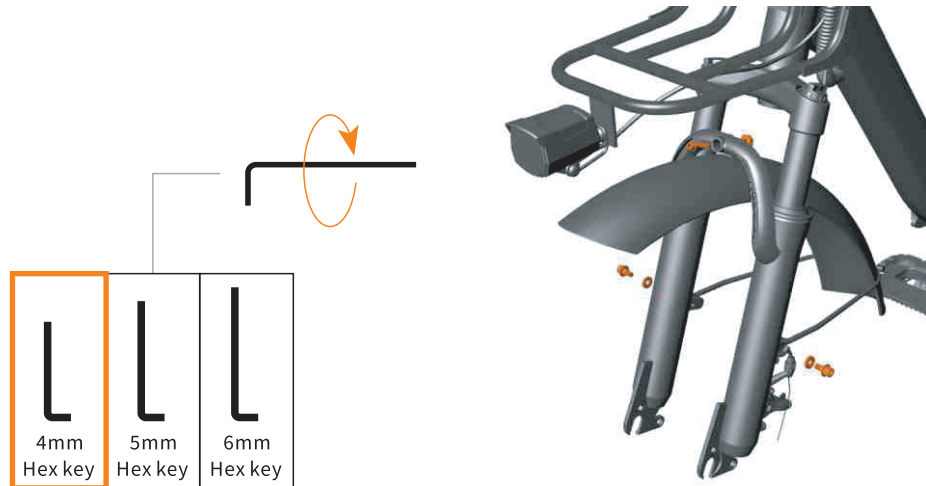

2.3.5 Place the nut and washer on the front wheel as shown in the figure below, following the sequence.



2.3.6 Clamp the front wheel with the front fork and lock the front wheel screw with a 15mm open-end wrench.

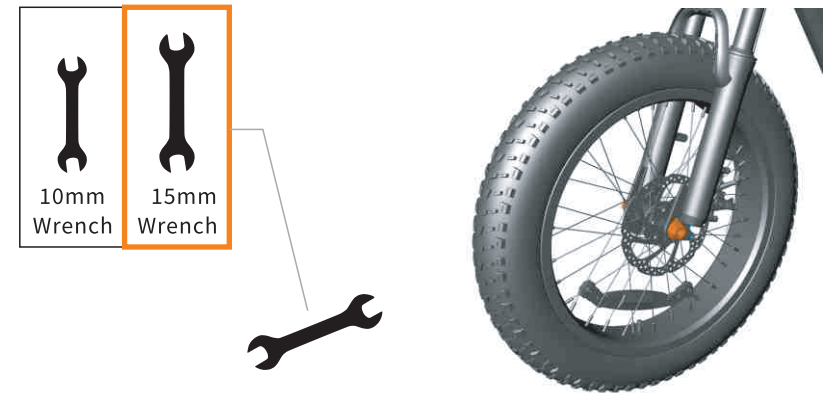

2.3.7 Remove the foam wrapped around the rear fender, as shown in the figure below. Align the rear fender bracket with the installation hole and tighten the screw using an 4 hex wrench.



2.3.8 Take the cargo rack out of the cardboard box, remove the wrapped foam, align it with the installation hole as shown in the figure below, and tighten the screw with an 4 hex wrench.

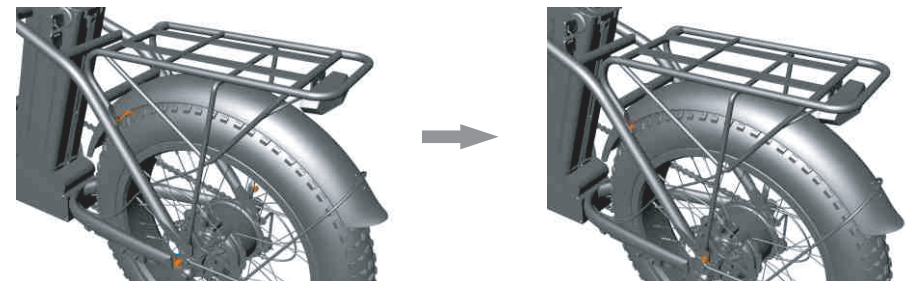

2.3.9 When installing the pedals, note the markings "R" (right) and "L" (left). The pedal marked with "R" should be installed on the right side of the bike and tightened clockwise with a 15mm open-end wrench; The pedal marked with "L" should be installed on the left side of the bike and tightened counterclockwise with a 15mm open-end wrench.



2.3.10

*Release the handle of the seat tube clamp and insert the seat tube into the middle tube of the frame.

*Adjust the seat cushion to the appropriate height and press the seat tube clamp handle by hand to secure it firmly.

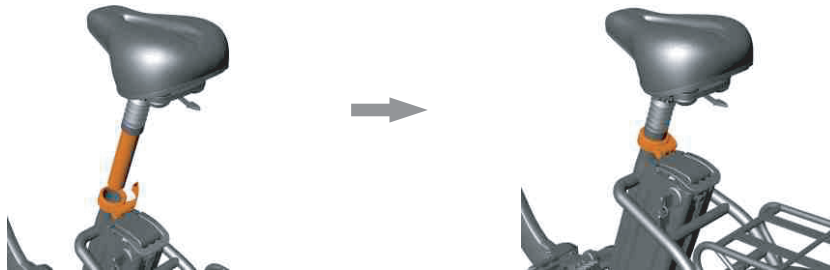

2.3.11 Installation of headlights and rack Take the rack out of the cardboard box, align it with the four holes of the head tube, and tighten it with a 5mm hexwrench. Remove the foam wrapped around the headlights, locate the hole in front of the basket, and tighten it with a 4mm hex wrench.

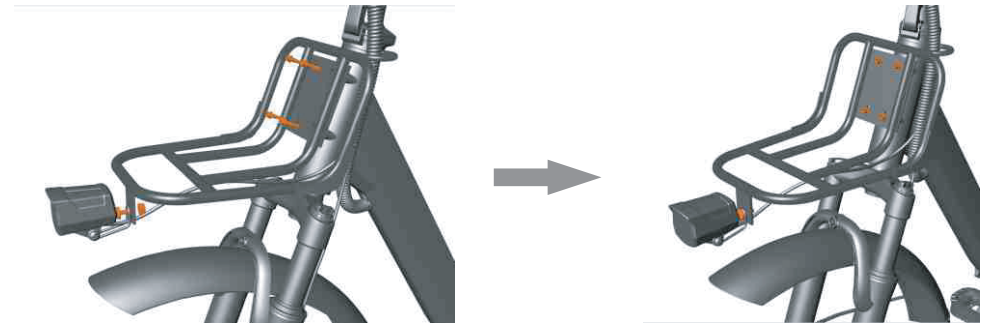

3. Pre-ride Instructions

3.1 Riding Techniques

*When the vehicle display is set to 0, the motor is in a no-output state, and the vehicle can be ridden like a normal bicycle.

*When the display is set to 1-5, it represents different speed levels, with 1 being the slowest and 5 being the fastest. Lower settings will make your battery last longer and make your ride safer.

*Use the shifter to maintain the optimal pedaling frequency with the motor speed, making the riding experience more effortless.

*When shifting gears with the mechanical transmission, lightly step on the pedal to reduce wear on the transmission system.

*When riding in the rain, please maintain a low speed, which will provide greater traction for the tires.

*Heavier loads will increase battery consumption.

*Do not start the bicycle by placing your foot on the pedal, as this may cause the vehicle to suddenly accelerate. The correct way to start is to sit on the seat, hold the handlebars with both hands, and then turn on the vehicle.

3.2 Pre-ride Preparation

Regardless of your level of experience, you should carefully read the "User Manual" and perform a safety check on the vehicle. In addition, please make sure you are familiar with the following vehicle-related information.

Before riding, please check the following information about the vehicle:

*Whether key parts such as the front wheel, rear wheel, saddle, and handlebars are loose. If they are loose, they must be tightened before riding.

*Whether the tire pressure is normal.

*Whether the battery is fully charged.

*When riding at night, check if the front and rear lights of the vehicle are working properly.

*Whether the display components of the instrument are displaying correctly.

*Please wear a cycling helmet and protective gear in accordance with local laws and regulations.

4. Instrument Panel Instructions

4.1 Product name and model

Intelligent LCD display for e-bike; model: YL80C.

4.2 Specifications

- 36V/48V power supply
- Rated working current 15mA
- Maximum working current 30mA
- Leakage current at power-off <1uA
- Working current at the supply controller end 50mA
- Working temperature -5~45°C

4.3 Appearance and dimensions



Picture of Display 80C



Picture of Display 80C Buttons

4.4. Function overview and functional area layout

4.4.1 Function overview



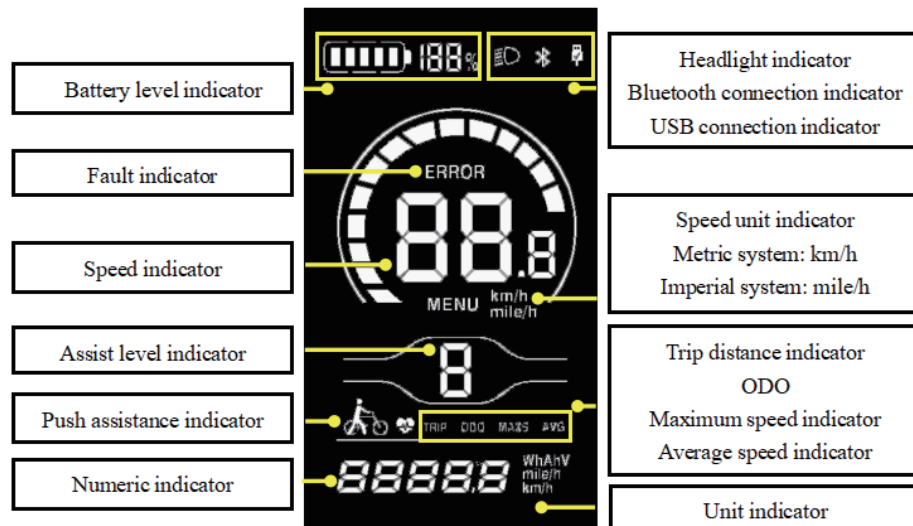

Display YL80C provides a variety of functions to meet your riding needs, including:

- Battery level indicator
- Motor power indicator
- Assist level adjustment and indication
- Speed indicator (including real-time speed, maximum speed and average speed)
- Distance indicator (including trip distance and ODO)
- Push assistance control and indication
- Headlight control and indication
- Error code indicator
- USB connection indicator (reserved)
- Heart rate indicator (reserved)
- Bluetooth connection indicator (reserved)
- Custom parameter setting (e.g., wheel diameter, speed limit, battery level, assist level, power-on password, controller current limit, etc.)
- Reset function

4.4.2 Functional area layout





4.4.3 Button definitions

There are five buttons on the operating unit of display YL80C, i.e., the on/off button , plus button , minus button , headlight button  and switching button .

4.5 General operation

4.5.1 Power on/off



By pressing and holding the button , the display will start to work and the working power supply of the controller will be turned on. In the power-on state, by pressing the button , your e-bike will be powered off. In the power-off state, the display will no longer use the battery power, and its leakage current will be less than 1uA.

■ If your e-bike is not used for more than 10 minutes, the display will be automatically powered off.

4.5.2 Display interface



After the display is turned on, the display will show the real-time speed (km/h) and the trip distance (km) by default. By pressing the button , the information displayed will be switched between the trip distance (km), ODO(km), maximum speed (km/h), average speed (km/h) and riding power.

4.5.3 Push assistance



By pressing and holding the button , the electric push assistance mode will be enabled. Your e-bike will run at the constant speed of 6km/h. The display will show . By releasing the button , your e-bike will immediately stop power output and return to the state before push assistance.

■ The push assistance function can only be used when you are pushing your e-bike. Please do not use it during riding.

4.5.4 Headlight on/off

By pressing the button , the controller will turn on the headlights and the display backlight will turn dark; by pressing the button  again, the controller will turn off the headlights and the display backlight will resume the luminance.

4.5.5 Assist level selection

By pressing the button  / , the e-bike assist level will be switched to change the motor output power.

4.5.6 Battery level indicator

The battery level indicator consists of five segments. When the battery is fully charged, the five segments will be all on. In case of undervoltage, the outline of the battery indicator will flash, which means the battery has to be charged immediately.

4.5.7 Error code indicator

When a fault occurs in the electronic control system of your e-bike, the display will automatically indicate the error code. Detailed definitions of error codes are shown in Schedule 1.

■ When an error code appears on the display interface, please conduct troubleshooting in time. Otherwise, your e-bike will not work normally.

4.6 General setting

■ All parameters can only be set when your e-bike stops.

The steps for general setting are as follows:

In the power-on state, when the display shows the speed of 0,

- (1) Press and hold the buttons **+** and **-** at the same time for more than 2 seconds to enter the selection interface of general setting options;
- (2) Press the button **+** / **-** to switch the selection interface of general setting options, and press the button **i** to enter the parameter modification interface;
- (3) Press the button **+** / **-** for parameter selection;
- (4) Press the button **i** to save the parameter and return to the selection interface of general setting options;
- (5) Press and hold the button **i** to save the parameter and exit the selection interface of general setting options.

The following selection interfaces of general setting options are available:

4.6.1 Trip distance reset

tC refers to the trip distance reset item. tC-n means not to reset the trip distance, and tC-y means to reset the trip distance.

Press the button **i** to enter the parameter modification interface. Press the button **+** / **-** for parameter selection. Press the button **i** to save the parameter and return to the selection interface of general setting options.

4.6.2 Backlight luminance setting

bL refers to the backlight luminance setting option. Parameters bL-1, bL-2 and bL-3 are available, which represent the backlight luminance, 1 for the minimum luminance, 2 for the standard luminance and 3 for the maximum luminance.

Press the button **i** to enter the parameter modification interface. Press the button **+** / **-** for parameter selection. Press the button **i** to save the parameter and return to the selection interface of general setting options.

4.6.3 Metric/imperial system setting

Un refers to the metric/imperial system setting option. U-1 represents the imperial system, and U-2 represents the metric system.

Press the button **i** to enter the parameter modification interface. Press the button **+** / **-** for parameter selection. Press the button **i** to save the parameter and return to the selection interface of general setting options.

Schedule 1 Error Code Definitions

Error codes for protocols YL-01 and YL-02:			
Error codes for protocols YL-01 and YL-02:	Definition	Error codes for protocols YL-01	Definition
E001	Controller	E004	Throttle Abnormality
E002	Communication	E005	Brake Abnormality
E003	Motor Hall Signal	E006	Motor Phase Abnormality
Error codes for protocols YL-05, KDS and YL-J:			
Error codes for protocols YL-01 and YL-02:	Definition	Error codes for protocols YL-01 and	Definition
E001	Current	E004	Motor Hall Signal
E002	Abnormality	E005	Brake Abnormality
E003	Motor Phase	E006	Communication Abnormality

5. Battery and Charger

5.1 Battery technical data and precautions

For transportation safety, the battery is guaranteed to have 30-40% charge when it leaves the factory. This charge will decrease with the length of transportation time. When you receive your battery, please charge the battery before first use.

Battery capacity (AH)	13
Battery level (WH)	676
Rated voltage (V)	52
Maximum charging voltage (V)	58.8
Maximum charging current (A)	2
Battery type	Li-ion
Ambient operating temperature	-5~45°C
Cycle life	≥1000 times
Charging temperature	0~45 °C
Waterproof rating	IPX4

Your bicycle is powered by a lithium-ion (Li-Ion) battery. Please always follow the following instructions when operating, charging and using it:

- *The vehicle battery is only for use with this vehicle. It is strictly prohibited to connect the battery to other electronic devices, as this may risk damaging the battery.
- *Do not modify, open, or disassemble the battery pack. Modifying or disassembling the battery may cause short circuits, fires, or malfunctions.
- *The battery is heavy, please handle it with care to avoid dropping it.
- *Do not let any sharp or metal objects come into contact with the battery electrodes and charging ports, as there is a risk of short circuits and fires.
- *Do not let the battery overheat and avoid excessive exposure.
- *Do not expose the battery to open flames or high temperatures from radiators.
- *Do not immerse the battery in water.
- *Before performing tasks such as installation, maintenance, cleaning or repairs, turn off the power and unplug the charger or battery plug. When the bicycle is turned on, touching the contact points may cause electric shock or injury.

5.2 Battery Usage Instructions

Before mounting the battery, please make sure that there are no foreign objects in the electrode area of the vehicle. If there are any, they must be cleaned off, otherwise it will cause the risk of battery short circuit and damage. Steps matched with corresponding pictures.

5.2.1

*There is a long bar shaped handle under the seat. Press and hold the handle to flip the seat cushion upwards, as shown in the right picture;



*Align the battery with the slide to align with the seat tube, insert it directly into the bottom, insert the key into the keyhole, rotate clockwise, and the battery can be locked.



5.2.2 How to disassemble the battery

*After flipping the seat cushion over;

*Pull up the rubber plug, insert the key into the keyhole, press and turn the key counterclockwise, then remove the key, hold the battery handle, then remove the key, lift the battery, and remove the battery.



5.3 Battery storage and disposal

5.4.1 Storage: If the bicycle is not used for a long time, please remove the battery and store it in a dry, well-ventilated place, and ensure that the storage temperature is between 25-35°C (77-95°F). Also, make sure to charge the battery at least once every three months to keep the battery level at least 3 bars (40-50%), which can effectively extend the battery life.

5.4.2 Disposal: When the battery is no longer usable, do not dispose of it in your household waste! All batteries and chargers must be disposed of in an environmentally friendly manner according to the battery disposal regulations of your country or region.

5.4 Charger Technical data and Precautions

AC input voltage (V)	100-240
Charging voltage (V)	58
Charging current (A)	2
Frequency (Hz)	50/60
Battery type	Li-ion
Ambient operating temperature	0~40 °C

The following regulations should be followed when using the charger:

- * The charger should be placed on a level and non-heated surface.
- * Charge the battery in a dry, well-ventilated place, and ensure that the charger is not covered during the charging process.
- * When charging the battery, connect the charger to the battery charging port first, and then connect it to the ac outlet.
- * Avoid bumping or impacting the charger, as it may damage the charger.
- * Avoid leaving the charger plugged into the battery for a long time. If the battery is fully charged, unplug the charger in a timely manner, as it may affect the battery's lifespan.

6. Common Faults and Maintenance

Sequence	Fault phenomenon	Fault cause analysis	Solution
1	Vehicle not powered	<ol style="list-style-type: none"> 1. Power lock not properly opened, battery not supplying power properly. 2. Battery not installed properly. 3. Power switch circuit loose or disconnected. 4. Battery not powered. 	<ol style="list-style-type: none"> 1. Turn the ignition lock to the ON position, then power on. 2. Install the battery properly. 3. Open the frame electronic control component installation box, connect the wires properly. 4. Contact your retailer for assistance.
2	Vehicle does not move after powering on	<ol style="list-style-type: none"> 1. Check if power select, level is iset, set to 1-5, if it is in gear 0, the motor will not output power. 2. Loose or disconnected speed control lever circuit. 	<ol style="list-style-type: none"> 1. Adjust the instrument to gears 1-5 and use the speed control lever or start with pedal assist. 2. Connect the speed control lever circuit properly. 3. Contact your retailer for assistance.
3	The vehicle rides normally and the instrument panel does not show the speed.	<ol style="list-style-type: none"> 1. The white speed wire at the controller end is loose or disconnected. 2. Instrument panel malfunction. 	<ol style="list-style-type: none"> 1. Open the frame electronic control component installation box and connect the white speed wire. 2. Contact your retailer for assistance.
4	The front/rear lights are not working	<ol style="list-style-type: none"> 1. The front/rear light wires are loose or disconnected. 2. Front/rear light malfunction. 	<ol style="list-style-type: none"> 1. Open the frame electronic control component installation box and connect the front/rear light wires. 2. Contact your retailer for assistance.
5	Gear shifting is not smooth	<ol style="list-style-type: none"> 1. The rear derailleur protector is deformed. 2. The gear shifting wire is loose. 	<ol style="list-style-type: none"> 1. Use a wrench to restore the rear derailleur protector to its normal position. 2. Adjust the gear shifter fine-tuning screw.

7. Warranty Service

7.1 Warranty Terms

7.1.1 The warranty only applies to the original owner of the electric bike purchased through Engwe online or physical stores.

7.1.2 The warranty period starts when the customer receives the electric bike and terminates immediately upon the expiration, sale, or transfer to another person. Any subsequent owner or transferee is not eligible for the limited warranty.

7.1.3 For non-human-induced damages during the warranty period, we will provide free replacement parts. After the warranty period, the customer is responsible for the cost of replacement parts and shipping.

7.2 Warranty Coverage

Warranty content for accessories			
	Accessory name	Shelf life	Quality content
Basic accessories	Frame	12 months	Natural deformation, welding, detachment, and fracture caused by manufacturing defects can be replaced. Self-modification and collision damage are not covered by warranty.
	Front fork assembly, handlebars, folding seat post, seat post.	12 months	Self-modification and collision damage are not covered by warranty.
	Tire	1 month	The tire is punctured by sharp objects, and tire problems caused by insufficient tire pressure or crossing speed bumps are not covered by warranty. Only products with quality problems upon receipt are eligible for warranty.

Basic accessories	Saddle, plastic parts, brakes, disc brake rotor, brake pads, brake cable	3 months	Parts damaged by collision or other causes are not covered by warranty. Damage crossing speed bumps is not covered by warranty.
	Motor Hall, motor bearing	12 months	Hall burnout, abnormal noise or rupture of bearing.
Battery	Battery casing, upper cover, lower cover, battery	12 months	Faults such as poor contact, power failure, no power storage, or capacity lower than 60% can be replaced. (Note: The warranty period for the battery does not restart, and the warranty period for the replaced battery is calculated based on the remaining days.) Water damage or damage caused by human factors is not covered by warranty replacement service.

The following conditions are not eligible for warranty:

- Malfunctions caused by the customer's failure to use, maintain, and adjust according to the user manual.
 - Malfunctions caused by the customer's self-disassembly, repair, modification, or failure to comply with the usage rules.
 - Malfunctions caused by improper use or storage by the customer or accidents.
 - Expenses incurred from repairs at other repair shops without our consent.
 - Slight scratches or damages to the outer packaging box of accessories due to logistics issues are not covered by the warranty.
 - Please contact us and obtain written approval before returning any items. Products returned without acceptance will not be refunded.
 - The warranty does not cover normal wear and tear of components.
 - Consumable parts (such as tires, saddles, plastic parts, brakes, brake rotors, brake pads, brake cables, surface scratches, etc.) are not covered by the warranty.
- Please kindly note: Used ebikes, modified ebikes are not covered by the warranty.

7.3 How to Apply for Warranty

Step 1: Take photos/short videos of your issue.

Step 2: Send a brief description of the problem, problem photos or videos, order number, and purchase platform to service@engwe-bikes.com.

Step 3: We will diagnose your problem, and if the problem is clear, we will provide a solution.

Step 4: When encountering problems that cannot be diagnosed initially, we will send you a troubleshooting file that will require you to perform tests according to our testing methods and provide corresponding videos or photos. We will provide a solution after receiving the testing videos or photos.

Step 5: We will verify your order information and delivery address, and resend the corresponding accessories to you.

7.4 Contact Us

1. Tell:

+33 805980036 (EU) Business hours: 9 am to 6 pm (Greenwich Mean Time +1), Monday to Friday

+1 8442007117 (USA) Business hours: 9 am to 6 pm (Pacific Standard Time, Starting at 8 am), Monday to Friday

2. Email:

service@engwe-bikes.com.

We usually reply within 1 working day.

8.Disclaimer

Please read the following carefully before using this electric bike. This disclaimer details your rights, responsibilities, and limitations when using the electric bike. By using this product, you agree to and accept the following terms:

1. Users must comply with all local laws and regulations, including but not limited to traffic rules, cycling safety standards, and legal restrictions on the use of this electric bike.

2. The vendor is not responsible for any malfunctions, accidents, or damages caused by the user's failure to operate, maintain, and adjust this product according to the user manual, maintenance manual, or safety guide.

3. Users are not allowed to disassemble, repair, or modify this product unless explicitly authorized by the vendor in writing. Any unauthorized modifications will void the warranty and increase the risks of use.

4. This product may involve certain risks, including but not limited to cycling accidents, falls, accidental collisions, or injuries. Users are responsible for their personal safety and should take appropriate safety measures when using this product.

5. The warranty for this product is limited to the defects and faults specified by the vendor. Damages, wear and tear, normal fatigue, or problems caused by accidents, improper use, storage, or maintenance are not covered by the warranty.

6. The vendor is not responsible for any damages or losses caused by logistics transportation. Users should inspect the packaging upon receipt and promptly contact the vendor to resolve any issues.

7. None of the terms in this disclaimer shall diminish the rights of users provided by applicable laws and regulations.

Please read and understand the above disclaimer carefully before using this product. If you do not agree with any of the terms, please do not use this electric bike. If you have any questions about any content in this disclaimer, please contact the Vendor for further explanation and guidance.