

OPTILAB PR-30 EVB USER'S MANUAL

Photo Receiver Evaluation Board

**Caution: The user must read this manual before operating the PR EVB.
Operations other than those described in this manual may result in personal
injury and damage to the unit.**

Ver. 2.1
August 23, 2021

Table of Contents

1. PR-30 Configuration.....	1
1.1 Butterfly Package Pin-out Diagram and Description.....	1
1.2 Bandwidth Adjustment.....	2
1.3 Operation Mode.....	2
2. Evaluation Board.....	3
2.1 Device Mounting Procedure.....	3
2.2 Schematic of Evaluation Board.....	4
2.3 Default Setting.....	5
2.4 Change the Settings.....	5
2.4.1 How to use manual gain control (MGC) mode.....	5
2.4.2 How to use automatic gain control (AGC) mode.....	6
2.4.3 How to monitor received signal strength.....	6
2.5 Operation Instruction.....	7

Optilab, LLC

600 E. Camelback Road, Phoenix, AZ 85012

Phone: (602) 343-1496, Fax: (602) 343-1489, Email: sales@oequest.com

1. PR-30 Configuration

1.1 Butterfly Package Pin-out Diagram and Description

PR-30 is packaged inside a 14-pin butterfly package. For your reference, we have included a table of the pin-out diagram for PR-30.

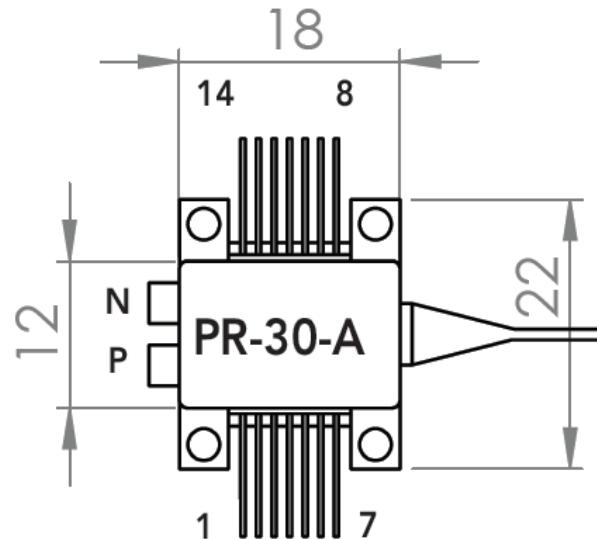

Figure 1 Butterfly Package Pin-out Diagram

Table 1. PR-30 Pin Out Configuration

Pin Configuration		
Pin 1	BWH	Bandwidth Coarse Adjust, GND, Floating or Vcc
Pin 2, 5, 7, 8, 12	Vcc	Filtered +3.3 V
Pin 3	GC	Gain Control in MGC mode. VCC, 0-3.3 V analog adjustment. Set to FLT for AGC mode
Pin 4	OA	Output Amplitude Adjust in AGC mode.
Pin 6	MC	Mode Control. GND= MGC mode, Floating = AGC mode
Pin 9, 11, 13	GND	Ground
Pin 10	RSSI	Received Signal Strength Indicator
Pin 14	BWL	Bandwidth Fine Adjust, GND, Floating or Vcc

Optilab, LLC

4350 E. Camelback Road, Suite E160, Phoenix, AZ 85018

Phone: 1-888-553-3888, Fax: (602) 343-1489, Email: sales@oequest.com

1.2 Bandwidth Adjustment

PR-30 offers a bandwidth adjustment feature that allows users to optimize optical receiver performance for different applications. PR-30 bandwidth can be adjusted as needed. The table below gives the bandwidth based on BWH and BWL settings when photo diode is reversed biased at 3.3V.

Table 2. Bandwidth Setting Lookup Table

BWH	BWL	Min. Bandwidth (GHz)
GND	VCC	13
GND	FLT	15
GND	GND	16
FLT	FLT	18
VCC	GND	20
VCC	FLT	20.5
VCC	VCC	21

In default setting on the evaluation board, both BWH and BWL are preset to VCC to achieve the largest bandwidth. If a bandwidth smaller than 13 GHz is desired, the user can lower VPD to further reduce the overall bandwidth of PR-30.

1.3 Operation Mode

PR-30 integrates a single, differential linear trans-impedance / variable-gain amplifier (TIA/VGA). The TIA offers two gain control modes: manual gain control and automatic gain control. In manual mode, MC pin should be connected to GND. The gain is adjustable from 50 Ω to 5000 Ω differential by adjusting the GC level. When MC and GC pins are floating, device is operating in automatic gain control (AGC) mode. In AGC mode, the gain is automatically adjusted to deliver a constant output voltage. The output amplitude is adjustable over 20 dB dynamic range by adjusting the level of OA.

Table 3. Operation Mode Selection

Operation Mode	MC Setting (Pin 6)	Amplitude / Gain Adjustment
Manual Gain Control	GND	GC (Pin 3), 0 ~ 3.3V
Auto Gain Control	FLT	OA (Pin 4), 0 ~ 3.3 V
Shut Down	VCC	N.A.

The default setting on the evaluation board is MGC. GC is preset to Vcc to maximize the TIA gain.

Optilab, LLC

600 E. Camelback Road, Phoenix, AZ 85012

Phone: (602) 343-1496, Fax: (602) 343-1489, Email: sales@oequest.com

2. Evaluation Board

The Evaluation Board for the PR-30 is used for ease of testing. It provides convenient access to all 14 pins and the data output ports. Utilizing a zero-insertion force configuration, the device can be mounted without the need for soldering as a user-friendly interfacing solution. The EVB is mounted on a base plate. The base plate can be further mounted to other structures using the four ¼-20 threaded through holes

2.1 Device Mounting Procedure

- i) Place PR-30 onto the evaluation board as show in Fig. 2. Pay attention to its orientation. The label P and N denotes the positive and negative RF output ports.
- ii) Align pins down into pin chuck. Make sure that they line up and don't cross over.
- iii) Mount PR to Evaluation board using the four 2-56 screws provided.
- iv) Once secured clamp pins down in pin chuck, as shown in Fig. 3.

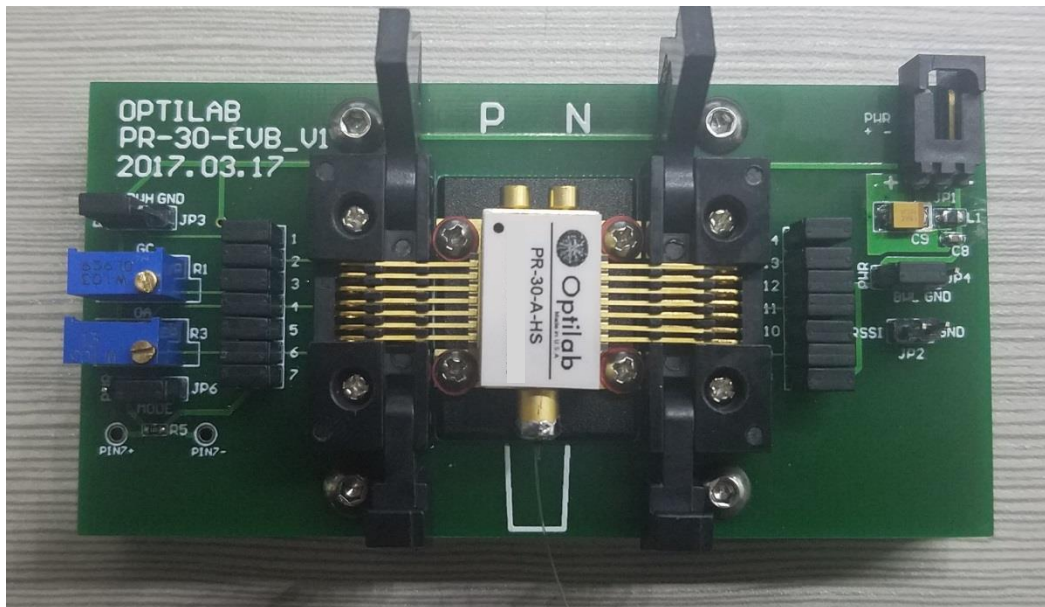

Figure 2. PR-30 mounting procedure

Optilab, LLC

600 E. Camelback Road, Phoenix, AZ 85012

Phone: (602) 343-1496, Fax: (602) 343-1489, Email: sales@oequest.com

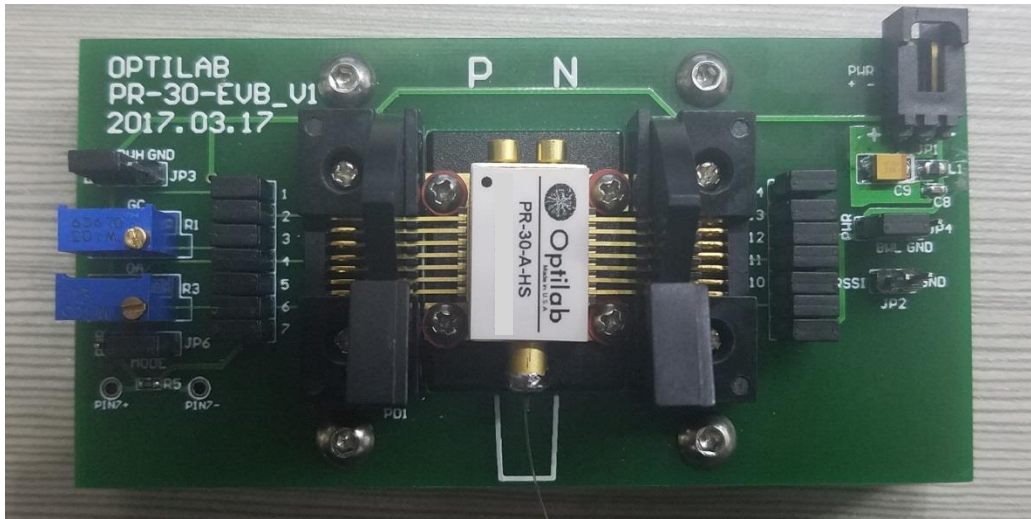

Figure 3. PR-30 clamped down on the EVB

2.2 Schematic of Evaluation Board

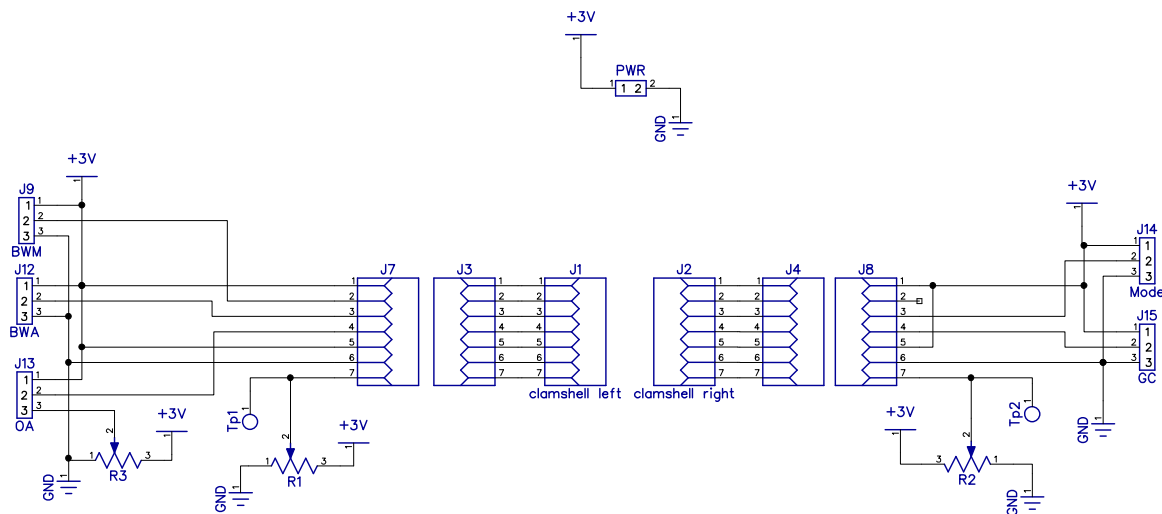

Figure 4. Schematic of Evaluation Board

An external power supply is connected through the power connecting plug. BWH (JP3) and BWL (JP4) are used to select bandwidth setting. Mode (JP6) is for operation mode selection. OA (R3) is used AGC mode for constant output amplitude adjustment. GC (R1) is used manual gain mode for constant gain setting. Test pins PIN7+/- are used to monitor the reverse bias voltage.

2.3 Default Setting

Figure 5 shows an evaluation board in the default setting. Black jumpers (included in the shipment) can be used to make connections between two pins adjacent to each other.

The evaluation board has been preset to MGC mode with the highest bandwidth setting. Photo diode is reversed biased at V_{cc} . The TIA gain is maximized ($GC = V_{cc}$).

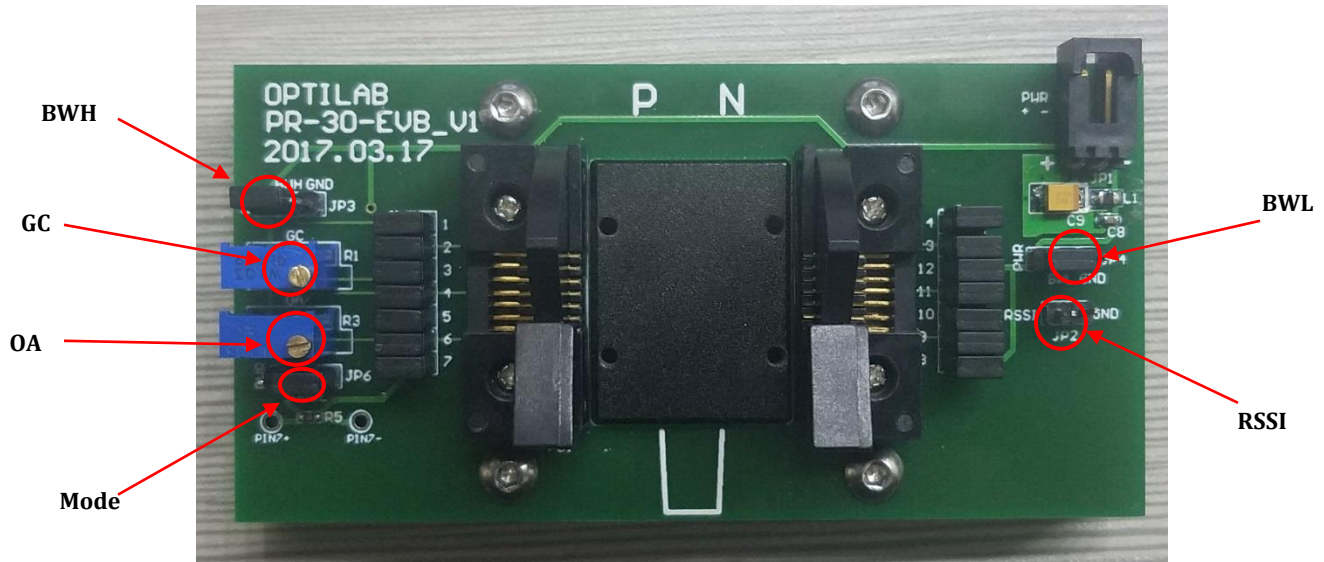

Figure 5. EVB Default Setting and Controls

2.4 Change the Settings

2.4.1 How to use manual gain control (MGC) mode

To use manual gain control mode, leave evaluation board in its default state, ensure Mode Pin (JP6) is jumped to pin 2 and 3. Adjust the differential gain by adjusting the potentiometer GC (R1), clockwise to increase gain.

Optilab, LLC

600 E. Camelback Road, Phoenix, AZ 85012

Phone: (602) 343-1496, Fax: (602) 343-1489, Email: sales@oequest.com

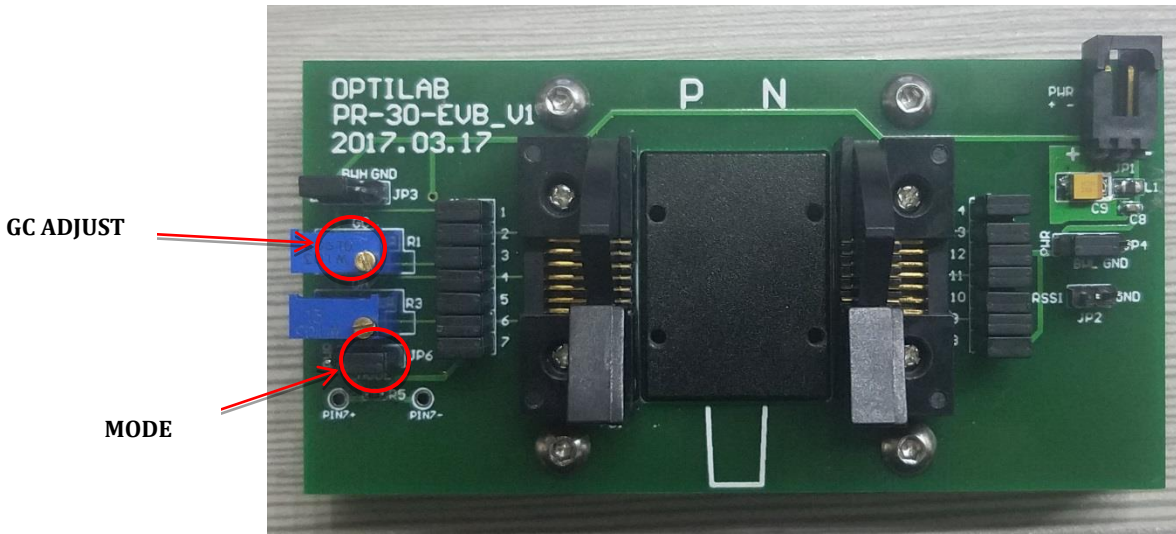

Figure 6. PR-EVB in MGC Mode

2.4.2 How to use automatic gain control (AGC) mode

To use automatic gain control mode, MC and GC pins have to be floating. First float Mode pin (JP6). Then float GC pin by removing jumper on pin 3. Adjust potentiometer R3 (OA) to the desired output amplitude, clockwise to increase amplitude

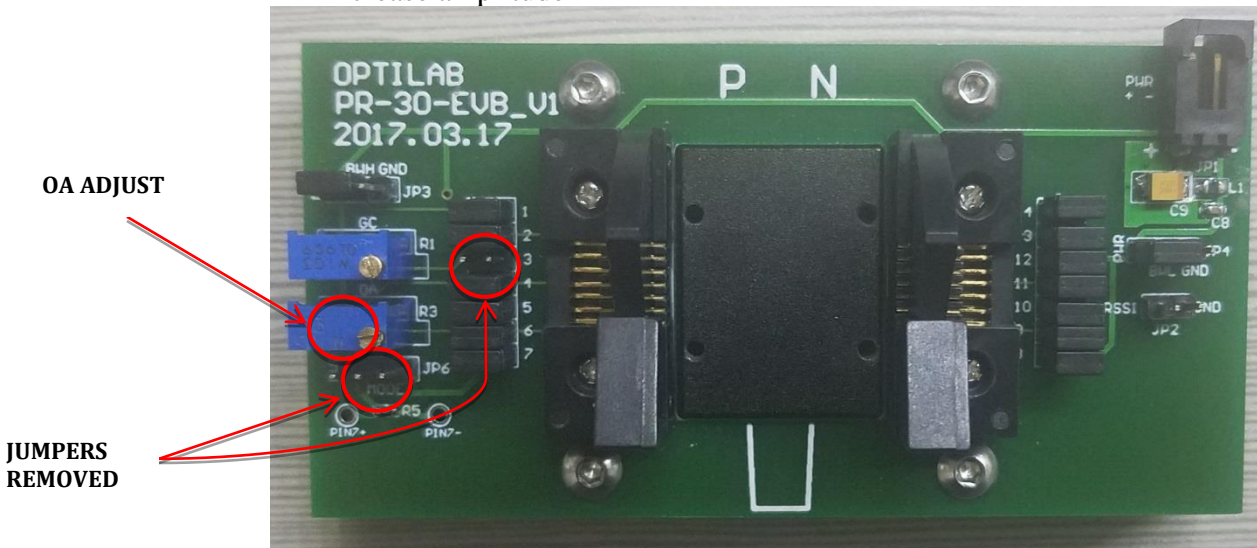

Figure 7. PR-30 EVB in AGC Mode

2.4.3 How to monitor received signal strength

Received signal strength indicator (RSSI) allows end user to monitor signal strength by simply probing onto two pin connector labeled RSSI (JP2).

2.5 Operation Instruction

Before powering up device make sure evaluation board is at factory default setting (see Fig. 5). This is especially important for first time user. Mount the device firmly as instructed in section 2.1. Use ESD strap during the handling.

Connect both RF output ports to the receiver instrument (e.g., CDR circuit, oscilloscope etc.) use a pair of RF cables with GPPO (SMPM) connector. These two RF output ports need AC coupling. Check the specification and setting of the instrument that the device is going to be connected to. If DC coupling scheme is used in the corresponding instrument, use external DC blocks in between. **DC coupling causes high current consumption of device which may damage TIA!!**

Connect 2-pin power connector on the right edge of evaluation board to an external DC power supply. A regulated DC voltage source with low voltage ripple is recommended. Set the current limit to 93 mA, ramp voltage up to 3.3V. Now device is operating in default setting (MGC mode).

To power off device, ramp DC power supply down until current consumption is low (typically around 1V) then turn off DC power supply.