



TWL-L-HP-B-M



DEVICE

L-Band Wavelength Tunable Laser Module, High Performance Version

OVERVIEW

The TWL-L-HP-B-M is a wavelength tunable laser module in C-band based on integrable tunable laser assembly (ITLA). The TWL-L-HP-B-M alleviates inventory and costs in high-channel-count DWDM systems by allowing a single device to replace to replace each of the single-channel devices. Full-band tunable assemblies also enable system functionality such as hot back-up and dynamic provisioning in addition to applications of optical regeneration and wavelength conversion, with the HP version also including a built in sweep function for continuous scanning applications. The TWL-L-HP-B-M has a low Relative Intensity Noise (RIN), a high Side-Mode Suppression Ratio (SMSR), an ultra narrow linewidth, and excellent wavelength accuracy. Its RS-232 control complies to OIF ITLA Multi Source Agreement (MSA) standard, with a provided GUI software for intuitive control of the wavelength and optical power. The TWL-L-HP-B-M can be used for Dense Wavelength Division Multiplexing (DWDM) optical transceivers and DWDM discrete line card designs.

FEATURES

- Wide wavelength tuning range 1570 nm – 1607 nm
- Precise Wavelength step resolution of 1 MHz
- High optical output power of 50 mW
- Continuous wavelength sweeping function
- Side Mode Suppression Ratio of 55 dB
- Polarization Maintaining Output (PM)
- Intuitive and easy to use USB interface
- Ultra narrow laser linewidth < 10 kHz

USE IN

- Optical Add/Drop Multiplexers
- Tunable DWDM transponders and transceivers
- Reconfigurable optical add/drop multiplexers
- Optical packet or burst-mode switching
- Test and measurement equipment
- Fiber sensing and interrogation
- Optical spectrum characterization
- DWDM transmission system

FUNCTIONAL DIAGRAM

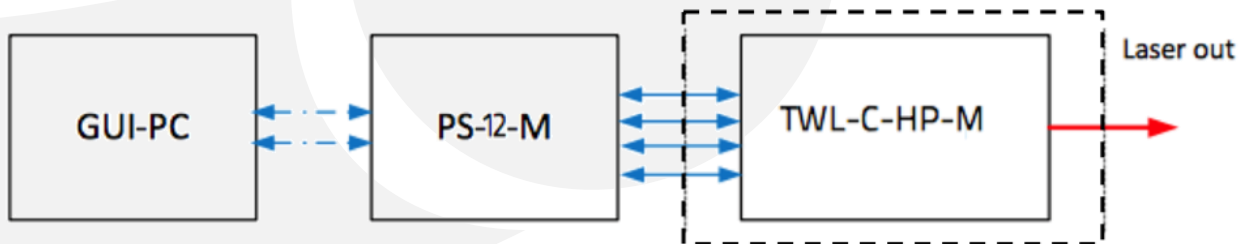



TWL-L-HP-B-M

SPECIFICATIONS

Operating Wavelength	1570 nm - 1607 nm
Wavelength Accuracy	± 1.5 GHz
Fine Tune Wavelength Resolution	1 MHz
Wavelength Stability	± 1 pm over 24 hours
Wavelength Sweeping	Continuous over full L-band range
Output Power	40 mW typ.
Output Stability	0.02 dB over 8 hours
Linewidth (FWHM)	< 10 kHz instantaneous w/o dither < 100 kHz w/ SBS disabled, < 750 MHz w/ SBS enabled
Carrier Noise Ratio	50 dBc typ. @ -5 dBm
Side Mode Suppression Ratio	55 dB typ.
Relative Intensity Noise (RIN)	-157 dB/Hz @ 13 dBm
Polarization Extinction Ratio	20 dB min.
Optical Isolation	30 dB min.
Fiber Type	Panda 1550 PM fiber

GENERAL

MECHANICAL

Power Supply Requirements	100 - 240 VAC
Optical Connectors	PM FC/APC standard, additional types available upon request
Operating Temperature	0°C to +40°C
Storage Temperature	-40°C to +70°C
Control/Monitoring	Output Power Level & Wavelength via GUI Software
Communication Interface	RS232 via DB9 Serial or USB 2.0
Power Supply	PS-5-M, +/-5 V Power Supply
Local Alarm	Over Temperature, Current Overflow
Housing Dimensions	120 mm x 112 mm x 32 mm





TWL-L-HP-B-M

MECHANICAL DRAWING

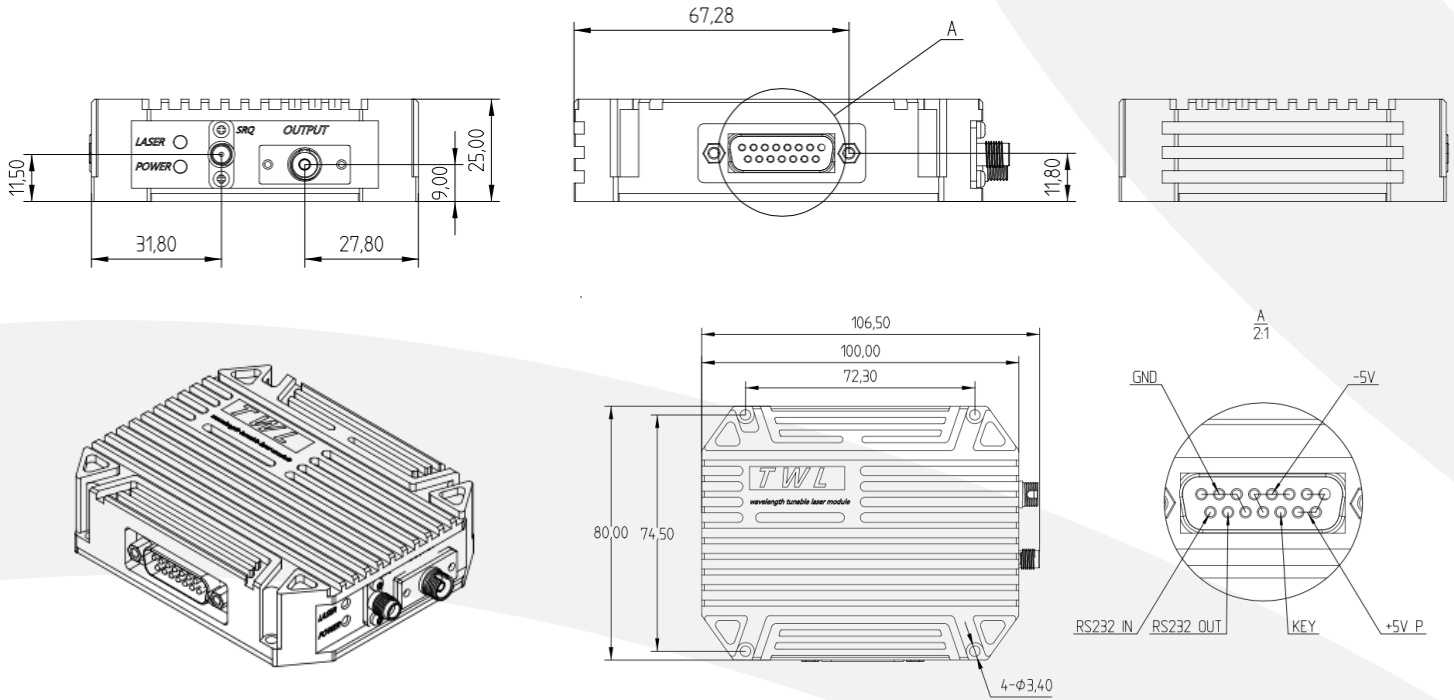

PIN OUT DIAGRAM

