



TWL-4-B



DEVICE

C/L-band Tunable Wavelength Laser Benchtop, 4 Channels

OVERVIEW

The Optilab TWL-4-B series are high spectral purity and stable tunable wavelength laser source. TWL-4-B features wide wavelength tuning range, narrow laser linewidth, high Side Mode Suppression Ratio (SMSR), excellent wavelength stability and optical output level exceeding 20mW. With the standard Polarization Maintaining (PM) fiber output, TWL-4-B offers a linearly polarized output. These features make the cost-effective TWL-4-B well-suited for many different applications, including DWDM device testing, optical sensing, and laboratory measurement applications. The TWL-4-B features four separate laser channels with independent software control, and is available in a standard benchtop housing. It includes an easy-to-use control software via USB interface for remote operation in laboratory environments. Contact Optilab for more information.

FEATURES

- 4 Optical Channels
- Narrow laser linewidth of 100 kHz
- Excellent Side Mode Suppression Ratio of 55 dB
- Wide tuning range from 1530 to 1607 nm
- Polarization Maintaining (PM) Output
- Intuitive and easy to use USB interface
- 1 year warranty

USE IN

- CWDM Networks
- Laboratory testing and measurement
- Seed Laser
- Fiber Optics Components Testing

FUNCTIONAL DIAGRAM

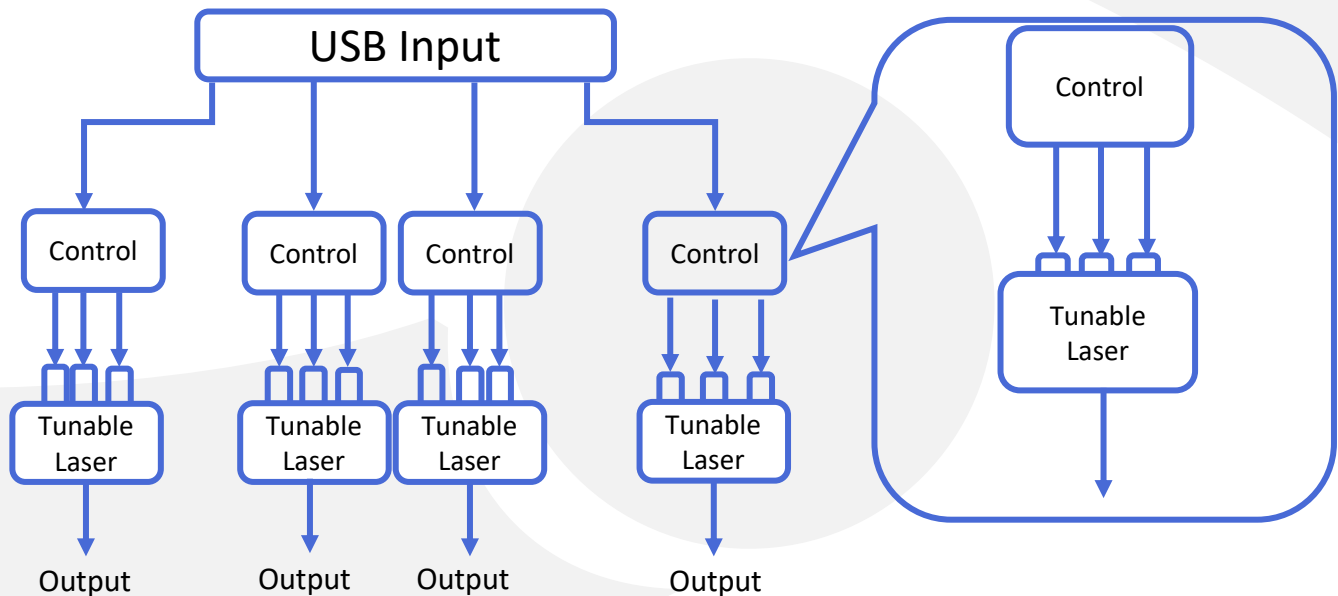



TWL-4-B

SPECIFICATIONS

Laser Wavelength Range	1530 nm to 1607 nm
Wavelength Accuracy	± 1.5 GHz
Wavelength Stability	± 1 pm over 24 hours
Output Power Level	20 mW (+13 dBm) max.
Output Stability	0.02 dB over 8 hours
Laser Linewidth	<100 KHz
Relative Intensity Noise	-150 dB/Hz typ.
Side Mode Suppression Ratio	55 dB typ.
Polarization Extinction Ratio	20 dB typ.
Optical Isolation	30 dB min.
Fiber Type	Panda 1550 PM Fiber
Number of Channels	Up to 4
Optical Connectors	PM Narrow Key, FC/APC or Customer Specified

GENERAL

CONTROL FUNCTIONS

Channel Spacing	25 GHz (0.2 nm)
Channel Grid	1 to 192
Channel Setting Time	10 sec. typ.
Output Power Adjustment	5 dB from max.
Dithering Frequency	0 to 375 MHz
Remote Control Interface	Serial via USB

MECHANICAL

Operating Temperature Range	0°C to +40 °C
Storage Temperature Range	-40°C to +70°C
Power Supply	80-240 V, 43-63 Hz AC, 1.5 A max.
Power Consumption	80 W max.
Display	Output Power Level, Wavelength
Controls	Output Power Level, Laser Wavelength, Dithering Freq.
Communication Interface	Serial via USB
Alarm	Over Temperature, Over Current
Dimensions	16.5" x 12.5" x 5.25"





TWL-4-B

ADDITIONAL INFORMATION

TWL-4-B has built-in wavelength locker also ensures precise wavelength setting of 10pm over life time of the device, which is 15 years along. The laser linewidth can be broadened up to 750MHz to address a variety of applications. Utilizing Telcordia qualified components, TWL tunable laser offers exceptional reliability and come with a standard 1-year limited warranty.

CHANNEL ON EXTENDED C-BAND (1559.04)

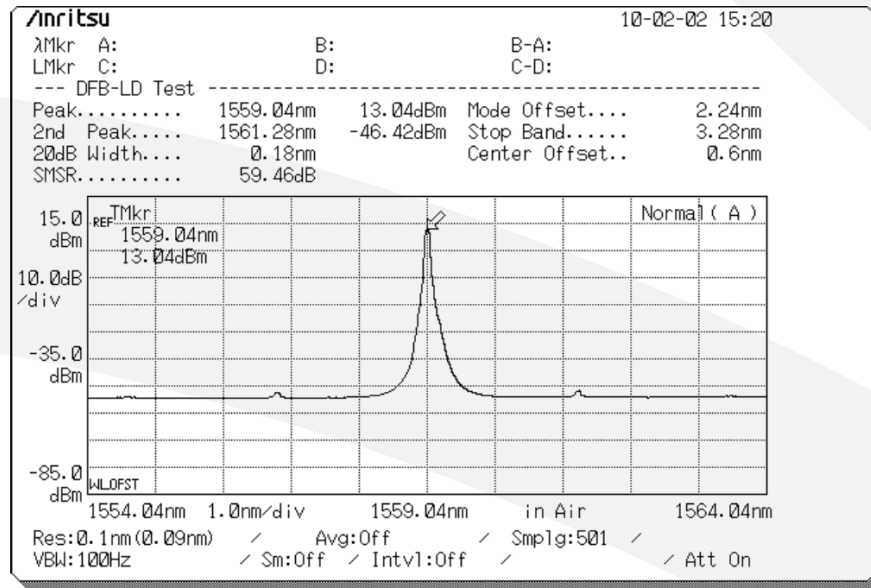

CHANNEL ON EXTENDED C-BAND (1607.08)

