

SPDC-1550-10-BC



1550 nm type-II SPDC Waveguide Chip, 10mm

OVERVIEW

SPDC-1550-10-BC is a 10mm length Periodically Poled Lithium Niobate (PPLN) waveguide chip designed to operate at 1550 nm. This chip may be used for Spontaneous Parametric Down-Conversion (SPDC) to create a pair of polarization correlated photon-pairs for Quantum Light Source (QLS) applications. Due to its well confined waveguide structure in Z-cut Lithium Niobate, the SPDC-1550-10-BC allows high power density to enhance the frequency conversion efficiency at wavelengths around 1550 nm when pumped by a 775 nm laser. The spectrum may be tuned by either slightly tuning the pump laser wavelength or by adjusting the temperature of the SPDC-1550-10-BC. Additional operating wavelengths with for Type-II SPDC may be ordered by contacting Optilab directly.

FEATURES

- Designed for Type-II SPDC
- Spatially Uniformed PPLN
- PM Fiber Pigtailed In/Out
- Polarization-Correlated Photon Pairs
- Titanium In-diffused Waveguide
- High Brightness
- Optimized for Conversion Efficiency & Loss

APPLICATIONS

- Quantum Photon Pair Generation
- Heralded Single Photon Source (HSPS)
- Fiber Based Quantum Optics
- Quantum Light Source (QLS)
- Quantum Key Distribution (QKD)
- EPR Photon Source

ONFIGURATION

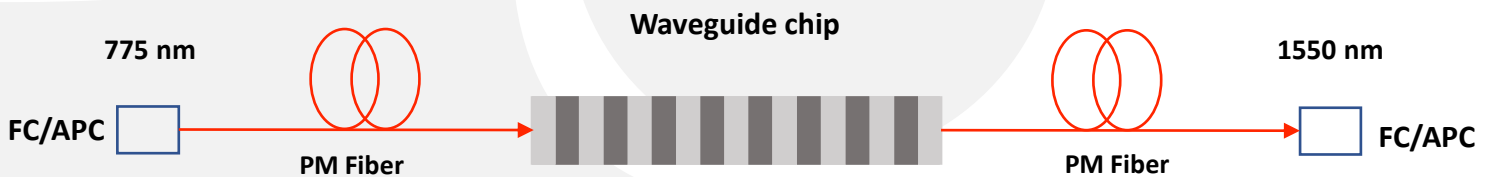

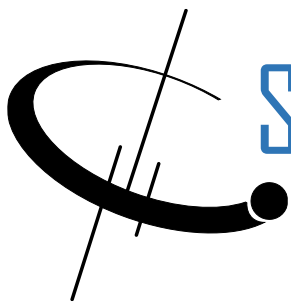

SPDC-1550-10-BC

SPECIFICATIONS

GENERAL

Substrate	Z-cut, X-propagation PPLN
Waveguide	Titanium In-diffusion
Pump Power @ CW	≤ 30 mW
Avg. pump Power @ pulsed pump*	≤ 50 mW
Degeneracy Bandwidth @ 1550nm FWHM	1.25 nm
Insertion Loss	≤ 3.0 dB (2.5 dB typical) @ 1550 nm
Input Fiber Type	PM850
Output Fiber Type	PM1550
In/Output Connector Type	FC/APC
Chip Dimension	10 mm (L) x 2 mm (W) x 0.5 mm (H)
Operating Temperature	+ 10 °C ~ + 60 °C
Storage Temperature	- 20 °C ~ + 80 °C

* Tested by femto-second laser under 76MHz repetition rate with pulse width of 600 fs.

SPDC

SPDC Operation	Type-II
Pump Wavelength	775 ± 1.5 nm
SPDC Degeneracy Wavelength	1550 ± 3 nm
SPDC Polarization	Cross Polarized
Photon-pair Generation Rate*	> 10 ⁷ Hz/mW
Brightness**	> 4 x 10 ⁶ Hz/mW/nm
SPDC Degeneracy Bandwidth	2.5 nm (typical) under CW pump
Temperature Tuning Coefficient	- 0.2 nm/°C

* Based on waveguide pump fundamental mode power = 1 mW.

**According to the SPDC degeneracy bandwidth.



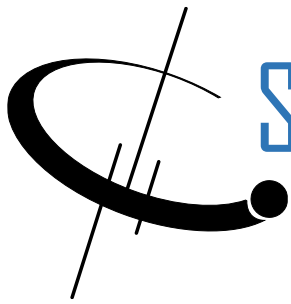

SPDC-1550-10-BC

TEST DATA

SPDC WAVELENGTH

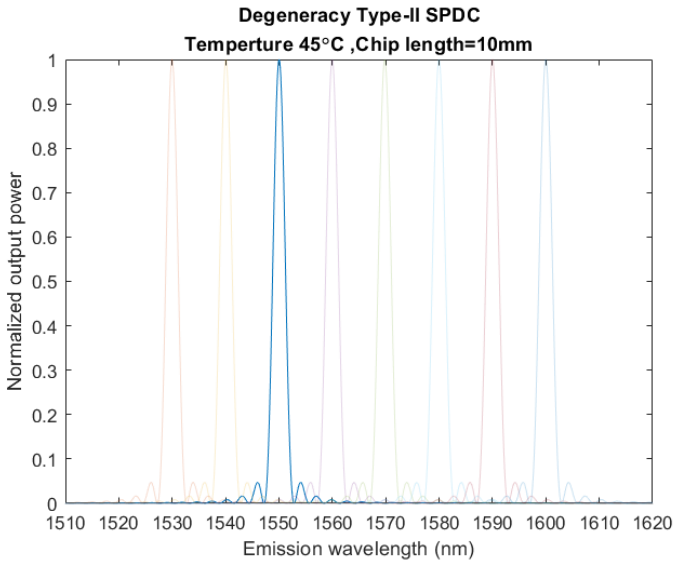

SPDC SPECTRUM

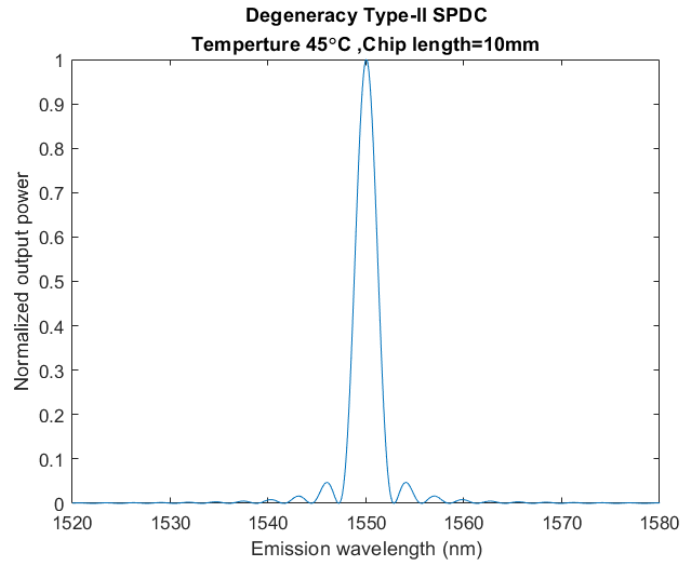

ORDERING OPTION

SPDC-XXXX-10-BC

Wavelength (nm)

XXXX: 1530 1540 1550 1560
1570 1580 1590 1600

*Other wavelengths are available upon request.



SPDC-1550-10-BC

APPLICATION DIAGRAM EXAMPLE

Spontaneous Parametric Down-Conversion Typical Schematic Diagram

$$\omega \rightarrow \omega + \omega$$

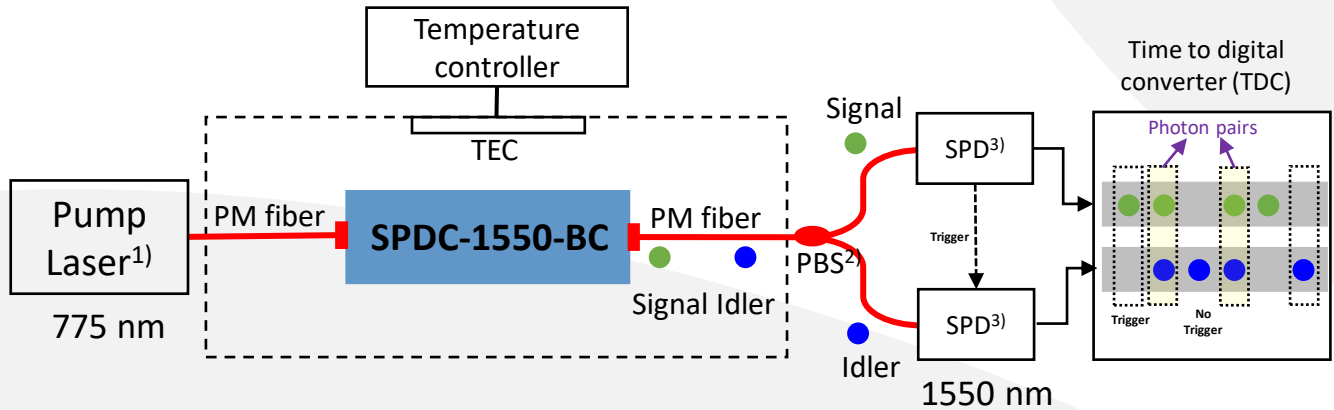

- 1) CW or Femtosecond Laser
- 2) Polarization Beam Splitter
- 3) Single Photon Detector

RELATED PRODUCTS

- SPDC-1550-10-M

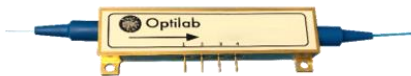

SPDC-1550-10-M is a periodically poled lithium niobate (PPLN) packaged & sealed module designed to operate at 1550 nm. Contact Optilab for more information

- SPDC-1550-10-MC



SPDC-1550-10-M is an Evaluation Module for periodically poled lithium niobate (PPLN) with built-in temperature controller, designed to operate at 1550 nm. Contact Optilab for more information

