

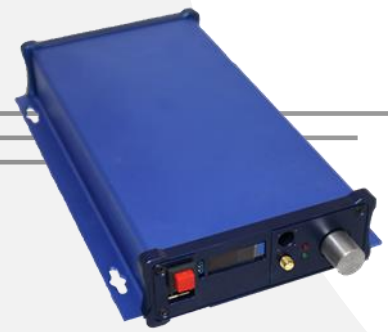

SNL-1550-PM-M



DEVICE

1550 nm Sub-Nanosecond Laser, PM Output, Module

OVERVIEW

The Optilab SNL-1550-PM-M is a programmable laser that produces sub-nanosecond pulses with electrical trigger input. It functions as a seed pulse generator for Master Oscillator Power Amplifiers (MOPA). The SPL-1550-PM-M is designed to produce < 1 ns widths and corresponding repetition rates up to 1 MHz from either internal pulse trigger or user's external electrical pulse generator. The SNL-1550-PM-M features an ultra-stable DFB laser diode, centered at 1550 nm transmission wavelength, but with the flexibility to offer other wavelengths. An optional EDFA is available to boost the pulse power. The module is equipped with a standard RS-232 interface for remote control and an OLED display screen for easy user interface, accessible through a front panel adjustment knob. Contact Optilab for more information.

FEATURES

- Optical pulse width < 1 ns
- High pulse contrast of -30 dB
- Internal or external electrical input
- 1540-1563 nm
- Programmable pulse width & repetition rate
- Optional high power EDFA
- Collimated output available

USE IN

- Sub-ns optical pulse generation
- Research & development
- Test & measurement
- Master Oscillator Power Amplifier (MOPA)

FUNCTIONAL DIAGRAM

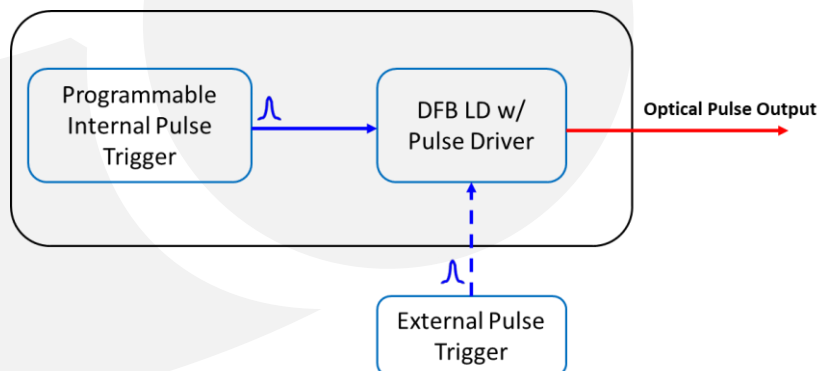



SNL-1550-PM-M

SPECIFICATIONS

OPTICAL

Laser Type	Distributed Feedback Laser (DFB)
Wavelength	1550 +/- 5 nm
Pulse Width	1 ns typ., 1.5 ns max.
Pulse Repetition Rate	1 Hz to 1 MHz, programmable
Pulse Contrast	-25 dB typ.
Peak Power Output (no EDFA)	> 50 mW
Energy per Pulse	Up to 1 uJ w/ EDFA, at 50 KHz
Jitter Relative to RF Reference	10 rms max.
Pulse Amplitude Variation	1% rms max.
Amplitude Stability (short term)	< 1%

EXTERNAL TRIGGER INPUT

Input Level	> 3 V peak to peak
Pulse Repetition Rate	< 1 MHz
Minimal Pulse Width	10 ns
Maximum Pulse Width	0.8* pulse spacing
Electrical Connector	SMA

MECHANICAL

Operating Temperature	0°C to +50°C
Storage Temperature	-40°C to +70°C
Humidity	10% to 90%
Power Supply	110 - 220 V AC, 50 or 60 Hz
Display	Internal trigger setting
Controls	Front Panel / USB .
Communication Interface	RS-232 interface
Dimensions	280 mm x 150 mm x 45 mm
Optical Connector	PM FC/APC or user option
Optical Fiber	PANDA Fiber PM
Electrical Connector	SMA Female

ORDERING OPTION

SNL-1550-XX-M

- XX None : Single Mode
- PM : Polarization Maintaining





SNL-1550-PM-M

MECHNICAL DRAWING (Panel difference may apply)

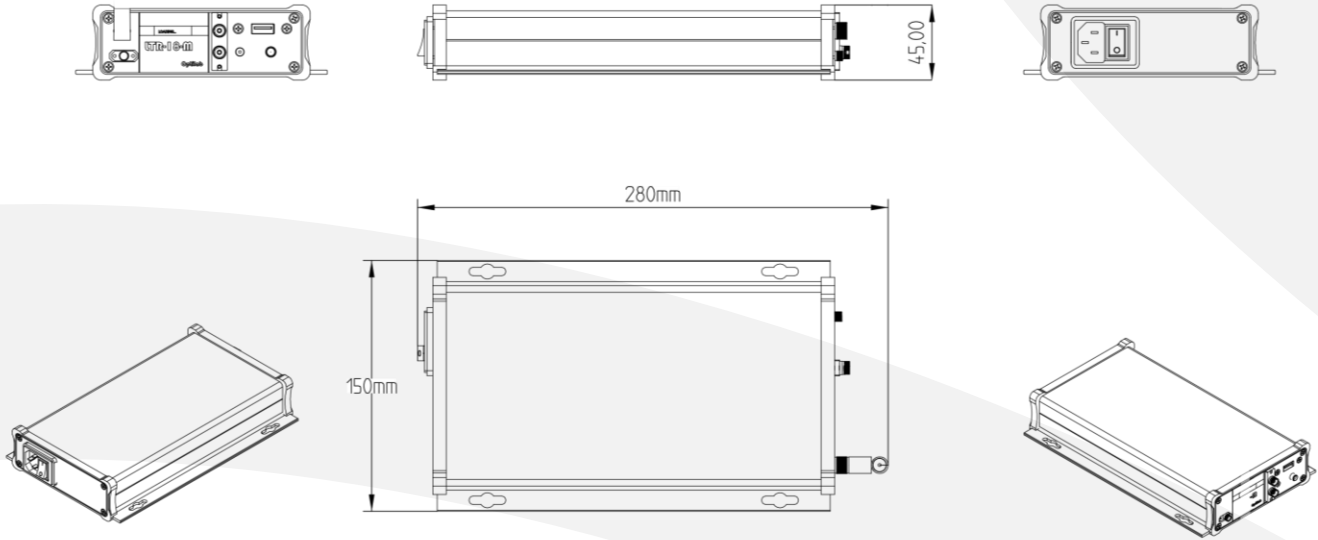

OPTICAL PULSE OUT

The SNL-1550-PM-M has a linear translation from electrical to optical pulses with a 1:1 ratio. The electrical and optical pulses look nearly identical. The following picture shows a typical optical pulse with 750 ps pulse width.

