

# Optilab EDFA-PA-M User's Manual

## Erbium Doped Fiber Amplifier – Pre-Amp Type Module

**Caution:** The user must read this manual before operating the EDFA-PA-M unit. Operations other than those described in this manual may result in personal injury and damage to the unit.

**Note that any attempt to open or fix the equipment without prior approval by Optilab, LLC. voids the warranty.**

Ver. 1.5  
May 8<sup>th</sup>, 2020



# Table of Contents

<b>1. GENERAL INFORMATION</b>	<b>1</b>
1.1 INTRODUCTION	1
1.2 PRODUCT OVERVIEW	1
1.3 FEATURES	1
1.4 USER SAFETY	2
<b>2. OPERATION</b>	<b>2</b>
2.1 INTRODUCTION	2
2.2 INITIAL INSPECTION	2
2.3 CONTROLS	3
2.4 DB15 PIN-OUT DIAGRAM	4
2.5 OPERATION INSTRUCTIONS	5
2.6 PC CONNECTION MODE	6
2.7 RS232 COMMAND SET	7
<b>3. TROUBLESHOOTING</b>	<b>8</b>
<b>4. SERVICE AND SUPPORT</b>	<b>9</b>
4.1 WARRANTY	9
4.2 SERVICE AND CALIBRATION	9
4.3 CARE OF FIBER-OPTIC CONNECTORS	10

## 1. General Information

### 1.1 Introduction

This manual contains information on the installation and operation of the EDFA-PA-M modular erbium doped fiber amplifier (EDFA) unit.

### 1.2 Product Overview

The Optilab EDFA-PA-M Pre-Amp EDFA is a high-gain, easy-to-use and cost-efficient solution for photonic subsystems, OEM integration, and fiber optic system integration. Using a high gain design, this module provides over 25 dB gain with a 4.5 dB noise figure and is designed to amplify signal with a low input level as low as -40 dBm. Pump laser protection and alarms are equipped to ensure the reliability and safety of the device. The module requires a single  $\pm 5$  Volt DC power supply for operation, a standard one-year warranty comes included with each EDFA-PA-M.

### 1.3 Features

- High gain of more than 25 dB
- Low noise figure
- Designed for low input level (as low as -40 dBm)
- Wide wavelength operation range
- Modular Design for OEM Integration

## **1.4 User Safety**

1. The EDFA-PA-M unit emits high intensity invisible light from the optical output receptacle. Avoid direct exposure to skin and eyes.
2. The module case is fully certified for EMS protection. The user should never open the module case; any attempt will void the warranty and may result in electric shock and EMS attack to equipment in the vicinity.
3. The user should avoid using any solvent or vaporizing chemical to clean the exterior. It may result in damage to the surface and internal circuits.

## **2. Operation**

### **2.1 Introduction**

This chapter describes how to operate the EDFA-PA-M unit, and discusses the location and function of the controls and connectors.

### **2.2 Initial Inspection**

Your EDFA-PA-M was carefully inspected before it left the manufacturer. It should be in proper working order upon receipt. You should, however, inspect the unit for any damage that may have occurred in transit. If the shipping container or the packing material is damaged, keep it until the contents of the shipment have been checked to be free of mechanical and electrical damages. Notify Optilab, LLC promptly if any notable damage is found.

2.3 Controls

**EDFA-PA-M – EDFA Module**

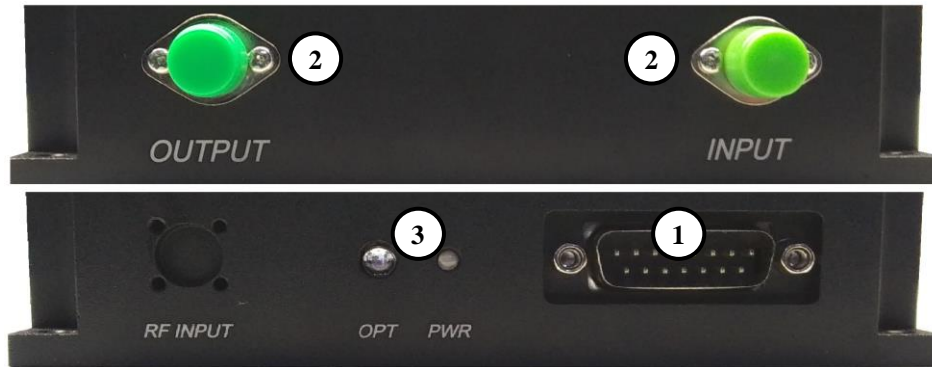

FEATURE	FUNCTION
① ELECTRICAL CONNECTION PORT	This port is used to connect the EDFA module to the power supply and RS232 cable. It is a DB15 type connector, with the full pin-out diagram shown on page 5 of this manual.
② OPTICAL INPUT AND OUTPUT FIBER PORTS	The optical input and output fiber ports for the EDFA unit. The fiber ports shown are FC/APC type.
③ STATUS LEDs	<p>These LEDs show the current status of the EDFA:</p> <p><u>Optic</u>: Blue – EDFA Power Switch is enabled; Red – EDFA Power Switch is disabled.</p> <p><u>Power</u>: Blue – Electrical power enabled; Off – Electrical power disabled.</p> <p>*Note – Optic LED not present on all units</p>

**An external optical isolator at specified wavelength should be used to protect the EDFA-PA-M from optical feedback and to improve stability**

## 2.4 DB15 Pin-Out Diagram

Listed below is the pin-out diagram for the DB15 pin port on the external of the EDFA-PA-M module:

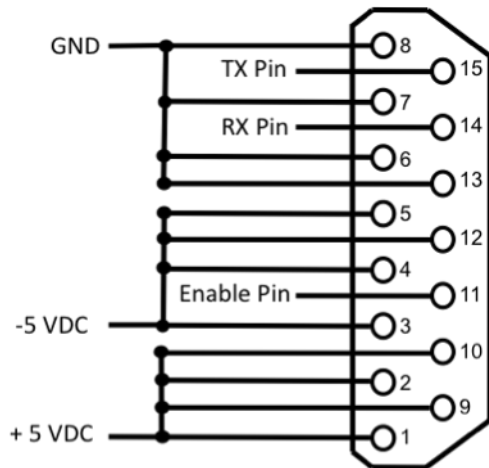

Pins 1, 2, 9, 10 – +5 VDC. It is important to have all pins connected for proper operation.

Pins 3, 4, 5, 12 – -5VDC. It is important to have all pins connected for proper operation.

Pins 6, 7, 8, 13 – Ground

Pin 11 – Enable, short this pin to Ground to enable EDFA operation.

Pin 14 – RS232 RX, for receiving data via standard serial communication.

Pin 15 – RS232 TX, for transmitting data via standard serial communication.

## 2.5 Operation Instructions

### Start-up Procedure

1. Ensure that the proper cable connections are made, including the DB15 connection between the module and power supply.
2. Due to the increased temperature of the device over time, it is strongly recommended to use the EDFA in a well-ventilated area with an adequate heat sink in contact with the EDFA for proper heat dissipation.
3. After plugging in the appropriate power plug into the AC / DC Power Supply, flip the main AC switch to the ON position to enable electrical power to the unit. The AC/DC converter supply's LED will enable.
4. Ensuring the input signal is turned off, connect the optical signal for amplification via the optical input port using the indicated connector patchcords.
5. Connect the optical output port using the indicated connector patchcords to the appropriate signal destination to utilize the amplified optical output signal(s).
6. After checking all physical patchcord connections, turn the input signal laser source on.
7. Turn the EDFA / Power supply laser switch to the ON position.
8. The EDFA-PA-M is now enabled, with both status LEDs enabling to blue (if optical input is higher than -20 dBm).

### Patchcord Swapping Procedure

1. Turn the EDFA power switch to the OFF position to disable the EDFA-PA-M output.
2. Swap patchcords as desired. Only connect the indicated connector patchcords to the optical input/output receptacles, cleaning them as necessary.
3. Turn the EDFA power switch back to the ON position; normal operation will resume after a few seconds.

### Over-temperature Procedure

1. When the **Temp Overheat** warning enables the pump laser will shutdown automatically and the system will freeze up.
2. Flip the main AC switch to the OFF position.
3. Restart the unit using the Start-up Procedure described above.
4. To prevent temperature issues in the future, please allow for adequate ventilation and increased heat sinks for proper dissipation of heat.



## 2.6 PC Connection Mode

For the standard EDFA-PA-M, connecting the module to an external PC will allow for parameter monitoring and pump current adjustments.

Using the RS232 port on the cable assembly, connect the EDFA module to a PC using the following connection diagram and serial port settings:

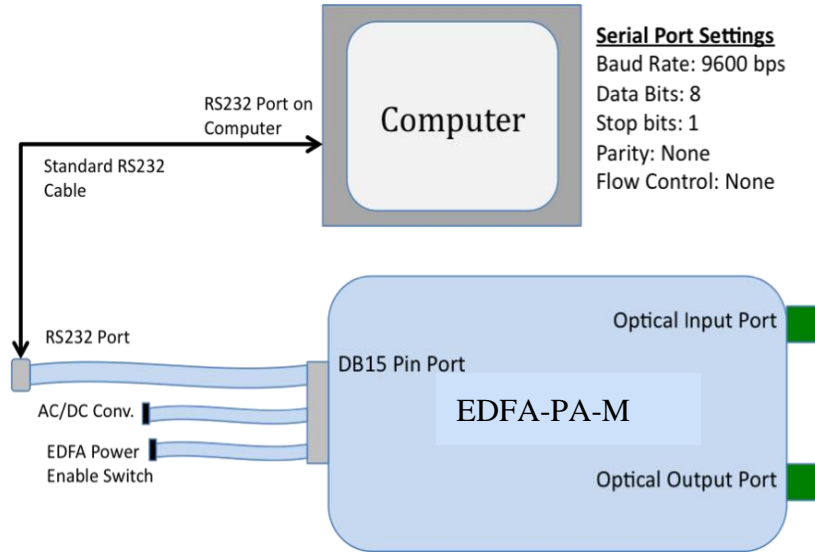

## 2.7 RS232 Command Set

When the electrical connections have been made, and the software settings for serial port transmission are set correctly, you are now able to send commands to the EDFA module.

COMMAND	DESCRIPTION	EXAMPLE	RESPONSE
SETADD	Sets the RS-485 Address (default is 1)	SETADD[X]{CR,LF} X = 0 through 9	ADDRESS:1
READXPA	Reads the equipment basic information.	READ1PA{CR,LF}	Optilab,LLC Model Type:EDFA-PA-M SN:9060001 Version:V1.0.0 Input:Low Output :12.52 dBm Temp:26 C
READXPAPC	Read the EDFA current limit	READ1PAPC{CR,LF}	PC is:250
READXPAC	Read the working current of the laser	READ1PAC{CR,LF}	the Current:130
SETXPALD	Initializes or disables the internal laser diode for amplification	SET1PALD:XXX{CR,LF} XXX = ON, Enable OFF, Disable	success SETPALD
SETXPAC	Read the working current of the EDFA. The value to be set should be a three-digit integer number. For two-digit value, a "0" should be used at the start bit.	SET1PAC:130{CR,LF}	the Current:130

## Troubleshooting

SYMPTOM	POSSIBLE CAUSE AND SOLUTION
OPTICAL OUTPUT POWER NOT HIGH ENOUGH.	<p><b>C:</b> No optical input or optical input power too small.  <b>S:</b> Check optical input present or check optical input power is correct.</p>
	<p><b>C:</b> Optical input/output connectors dirty.  <b>S:</b> Disable optical output and clean optical connectors.</p>
	<p><b>C:</b> Use of incorrect optical adapters or connectors.  <b>S:</b> Use only the indicated optical adapters and connectors. If measurement instruments accept different connector type, then use hybrid patchcords.</p>
	<p><b>C:</b> Optical output connector damaged.  <b>S:</b> Measure optical output power with power meter and compare with readout on PC connection 'READ' command. Return to Optilab for repair if the difference is high (&gt;4 dB) and cannot be corrected by cleaning or replacing the optical connectors. Always apply dust cover plugs to unused optical ports to prevent the damage of optical connectors.</p>
EDFA MODULE IS OVERHEATING	<p><b>C:</b> Improper pin connections  <b>S:</b> If directly connecting the voltage to the DB15 pins, ensure that all +5 VDC pins are making adequate contact to your supply.</p>
	<p><b>C:</b> Insufficient ventilation / heat dissipation.  <b>S:</b> Place unit in well-ventilated area or supply additional fans for ventilation. You may need to add a heat sink for additional heat dissipation.</p>
OPTICAL OUTPUT POWER UNSTABLE.	<p><b>C:</b> Insufficient optical output isolation.  <b>S:</b> Connect isolator of corresponding wavelength to optical output connector.</p>
UNIT DOES NOT POWER UP.	<p><b>C:</b> Insufficient electrical voltage.  <b>S:</b> Check that the electrical supply is at least 110 VAC.</p>
	<p><b>C:</b> AC Power cord is loose.  <b>S:</b> Plug power cord is firmly into the unit.</p>
	<p><b>C:</b> Improper pin connections  <b>S:</b> If directly connecting the voltage to the DB15 pins, ensure that all +5 VDC pins are making adequate contact to your supply.</p>
UNIT RESETS OR BLINKS ON AND OFF.	<p><b>C:</b> Insufficient electrical voltage.  <b>S:</b> Check that the electrical supply is at least 110 VAC.</p>

### 3. Service and Support

#### 3.1 Warranty

Optilab, LLC guarantees its EDFA-PA-M unit is guaranteed to be free of defects for 1 year from the date of shipment. The guarantee does not cover any damages resulting from the misuse or improper handling of the equipment, or any incidental or consequential loss. Note that the warranty will be void upon any attempt to open or to fix the equipment by the user without prior approval of Optilab, LLC

#### 3.2 Service and Calibration

Your EDFA-PA-M unit has been designed to provide years of trouble-free operation. No internal maintenance is required provided that the equipment is properly handled, operated and kept away from contamination. For any questions regarding the operation and performance of the unit, please contact Optilab, LLC at:

Optilab, LLC  
600 E. Camelback Road  
Phoenix, AZ 85012

Phone: (602)-343-1496  
Fax: (602) 343-1489  
Email: [sales@oequest.com](mailto:sales@oequest.com)

### 3.3 Care of Fiber-optic Connectors

Damage to optical connectors account for more than 70 percent of equipment performance degradation. To avoid such damage, the user should use only industrial grade 99% pure isopropyl alcohol and follow the procedures below to keep the connectors, adaptors and receptacles clean.

#### **Cleaning Optical Connector End-face with Wipe and Alcohol**

To properly clean optical connectors utilizing lens tissue grade wipes and alcohol follow the procedure below. The moist wipe removes dust particles, oil and contaminants that may damage or blot the end-face of the connector during connection. The dry wipe removes residual alcohol that may be ignited by optical emission.

1. Disable the optical output and turn off unit to prevent accidental exposure or damage to the optical connector by optical emission.
2. Moisten a wipe with alcohol by placing on top of the alcohol dispenser and push down to saturate the wipe.
3. Place the moist wipe on a work surface, and place a second dry wipe next to it.
4. Wipe the optical connector, end-face down on the moist wipe 3 times and then repeat on the dry wipe.
5. Visually inspect the end-face of the optical connector with an optical microscope to verify cleanliness. Repeat steps 2 to 5 as needed.

#### **Cleaning Optical Connector Sides, Receptacles, Adaptors with Swab and Alcohol**

Dust or particles can adhere to the insides of receptacles and adaptors or the sides of the optical connector ferrule. Their presence can affect the alignment of the optical fiber connectors and increase connection loss. To properly clean optical connectors, receptacles, and adaptors utilizing a swab and alcohol follow the procedure below:

1. Disable the optical output and turn off unit to prevent accidental exposure or damage to the optical connector by optical emission.
2. Moisten the swab by placing it on top of the alcohol dispenser and push down to saturate the swab.
3. For receptacles, adapters, or other connection points, insert the moistened swab and rotate the tip 1/2 turn clockwise and counter-clockwise 6 times while applying light but firm pressure.
4. For fiber connectors, rotate the tip of the moistened swab 5 revolutions around the connector while applying light but firm pressure.
5. Visually inspect the end face of the connector with an optical microscope to verify cleanliness. Clean end-face as needed.