

Optilab EDFA-PA-L-R User's Manual

Erbium Doped Fiber Amplifier – Pre-Amp Type
Rackmount



**CAUTION –
USE OF CONTROLS OR ADJUSTMENTS OR PERFORMANCE OF PROCEDURES OTHER
THAN THOSE SPECIFIED HEREIN MAY RESULT IN HAZARDOUS RADIATION
EXPOSURE.**



**THE USER MUST READ THIS MANUAL BEFORE OPERATING THE PRODUCT.
OPERATIONS OTHER THAN THOSE DESCRIBED IN THIS MANUAL MAY RESULT IN
PERSONAL INJURY AND DAMAGE TO THE PRODUCT.**



Note that any attempt to open or fix the equipment without prior approval by Optilab, LLC voids the warranty.

Revision History

Ver. 1.3
Jan 4th, 2021

Table of Contents

1. General Information	1
1.1 Introduction	1
1.2 Product Overview	1
1.3 Features	1
1.4 User Safety	1
2. Operation	2
2.1 Introduction	2
2.2 Initial Inspection	2
2.3 Controls	3
2.4 Operation Instructions	4
2.5 PC Connection Mode	5
2.6 Remote Command Set	6
3. Troubleshooting	7
4. Service and Support	8
4.1 Warranty	8
4.2 Service and Calibration	8
4.3 Care of Fiber-optic Connectors	9

1. General Information

1.1 Introduction

This manual contains information on the installation and operation of the EDFA-PA-L-R Rackmount erbium doped fiber amplifier (EDFA) unit.

1.2 Product Overview

The Optilab EDFA-PA-L-R Pre-amp EDFA is a high-gain, easy-to-use and cost-efficient solution for photonic subsystems and fiber optic system integration. Using a high gain design, the EDFA provides over 25 dB gain with a 4.5 dB noise figure and is designed to amplify signal with a low input level as low as -40 dBm. Pump laser protection and alarms are equipped to ensure the reliability and safety of the device. Controllable either through the front panel LCD interface or through USB 2.0 control, the EDFA-PA-L-R offers superior integration, backed by a three-year warranty for long term operation.

1.3 Features

- High gain of more than 25 dB in the L-band region
- Low noise figure
- Designed for low input level (as low as -40 dBm)
- Wide wavelength operation range
- Rackmount Design for system integration

1.4 User Safety

1. The EDFA-PA-L-R unit emits high intensity invisible light from the optical output receptacle. Avoid direct exposure to skin and eyes.
2. The module case is fully certified for EMS protection. The user should never open the module case; any attempt will void the warranty and may result in electric shock and EMS attack to equipment in the vicinity.
3. The user should avoid using any solvent or vaporizing chemical to clean the exterior. It may result in damage to the surface and internal circuits.

Optilab, LLC

600 E. Camelback Road, Phoenix, AZ 85012

Phone: 1-602-343-1496, Fax: (602) 343-1489, Email: sales@oequest.com

2. Operation

2.1 Introduction

This chapter describes how to operate the EDFA-PA-L-R unit, and discusses the location and function of the controls and connectors.

2.2 Initial Inspection

Your EDFA-PA-L-R was carefully inspected before it left the manufacturer. It should be in proper working order upon receipt. You should, however, inspect the unit for any damage that may have occurred in transit. If the shipping container or the packing material is damaged, keep it until the contents of the shipment have been checked to be free of mechanical and electrical damages. Notify Optilab, LLC promptly if any notable damage is found.

2.3 Controls

EDFA-PA-L-R – Front and Rear Panels



Feature	Function
① Front Panel LCD	Displays the current features and functions of the rackmount EDFA system.
② Optical Input and Output Fiber Ports	The optical input and output fiber ports for the EDFA unit. The fiber ports shown are FC/APC type.
③ Arrow Selector Buttons	These buttons navigate the front panel LCD display, as well as enable editing of the pump laser driving current.
④ EDFA Enable Key Switch	This key provides a key accessed enable / disable switch for the EDFA system.
⑤ AC Input and Main Power Switch	Accepts the standard 110/220 VAC power plug, with main power switch enabling / disabling electrical power to the rackmount EDFA system
⑥ USB 2.0 Port	This connection is used for remote access of the EDFA system, this port is 2.0 USB protocol type. Please see page 6 for more details on the remote access commands.
⑦ Interlock	This BNC female connector is a safety interlock. It must be shorted in order for the pump lasers to enable. Use the provided accessory to short this port or connect it to a compatible interlock device. If the interlock is open during normal operation, the pump lasers will be turned off. To re-enable the pump laser output, turn the output switch on the front panel to “OFF” position first and start over.
⑧ Ventilation Fans	The ventilation fans ensure proper ventilation inside the unit. The back panel of this equipment should be placed at least 3 inches from the wall to dissipate heat effectively.

Optilab, LLC

600 E. Camelback Road, Phoenix, AZ 85012

Phone: 1-602-343-1496, Fax: (602) 343-1489, Email: sales@oequest.com

An external optical isolator at specified wavelength should be used to protect the EDFA-PA-L-R from optical feedback and to improve stability

2.4 Operation Instructions

Start-up Procedure

1. After plugging in the appropriate power plug into the AC/DC Power Supply, flip the main AC switch to the On position to enable electrical power to the unit. The front panel Power LED will enable.
2. Ensuring the input signal is turned off, connect the optical signal for amplification via the optical input port using the indicated connector patchcords.
3. Connect the optical output port using the indicated connector patchcords to the appropriate signal destination to utilize the amplified optical output signal(s).
4. After checking all physical patchcord connections, turn the input signal laser source on.
5. Turn the EDFA Enable Key switch to the On position.
6. The EDFA-PA-L-R is now enabled.

Output Power Adjustment Procedure

1. Using the front panel arrow selector buttons, press the Up or Down buttons to highlight the following screen:



2. Press the center button to enable editing of the pump laser diode current. Pressing the Up and Down button will adjust the current selected digit, and the Right and Left arrows to select the appropriate digit to adjust (up to the hardware limited maximum setting).
3. When finished, press the center button again to confirm the settings, with the front panel reflecting the change.

Patchcord Swapping Procedure

1. Turn the EDFA Enable Key switch to the OFF position to disable the EDFA-PA-L-R output.
2. Swap patchcords as desired. Only connect the indicated connector patchcords to the optical input/output receptacles, cleaning them as necessary.
3. Turn the EDFA Enable Key switch back to the ON position; normal operation will resume after a few seconds.

2.5 PC Connection Mode

For the standard EDFA-PA-L-R, connecting the rackmount unit to an external PC will allow for parameter monitoring and pump current adjustments.

Using the front panel USB 2.0 port and an appropriate serial terminal communication program (such as Termit), connect the EDFA to a PC using the following connection diagram and serial port settings:

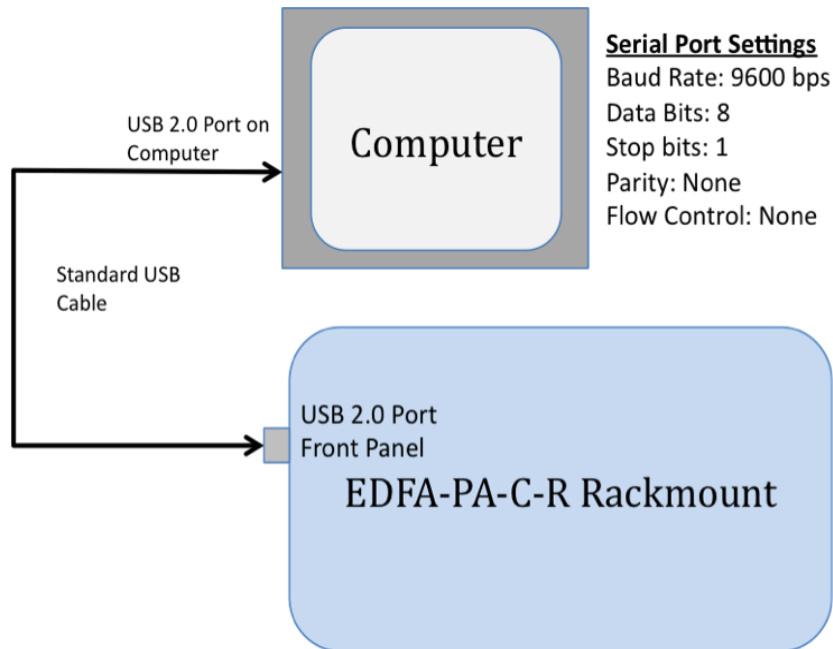

2.6 Remote Command Set

When the electrical connections have been made, and the software settings for serial port transmission are set correctly, you are now able to send commands to the LR module.

Command	Description	Example	Response
READ	Reads the equipment basic information.	READ{CR,LF}	Optilab,LLC Model Type:EDFA-PA-L-R SN:XXXXXXX Version:V2.0.0 Input:Low Output :12.52 dBm
READC	Read the working current of the EDFA	READC{CR,LF}	the Current:130
SETC	Set the working current of the EDFA. The value to be set should be a three-digit integer number. For two-digit value, a "0" should be used at the start bit.	SETC:130{CR,LF}	the Current:130

The screenshot below shows a typical response for the 'READ' command:

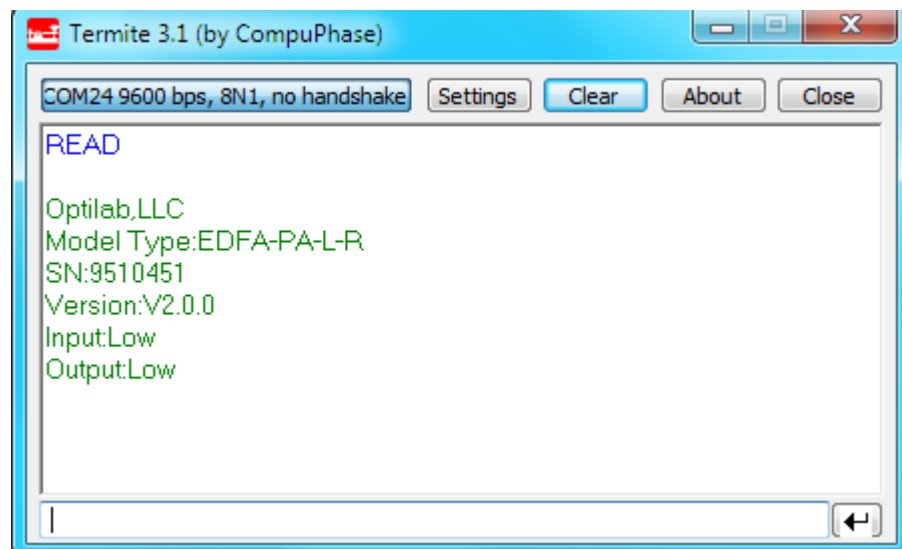

3. Troubleshooting

Symptom	Possible Cause and Solution
Optical output power not high enough.	C: No optical input or optical input power too small. S: Check optical input present or check optical input power is correct.
	C: Optical input/output connectors dirty. S: Disable optical output and clean optical connectors.
	C: Use of incorrect optical adapters or connectors. S: Use only the indicated optical adapters and connectors. If measurement instruments accept different connector type, then use hybrid patchcords.
	C: Optical output connector damaged. S: Measure optical output power with power meter and compare with readout on PC connection 'READ' command. Return to Optilab for repair if the difference is high (>4 dB) and cannot be corrected by cleaning or replacing the optical connectors. Always apply dust cover plugs to unused optical ports to prevent the damage of optical connectors.
	C: Pump current setting is too low S: Check the front panel or remote read command for the current pump current setting, making adjustments as necessary.
Optical output power unstable.	C: Insufficient optical output isolation. S: Connect isolator of corresponding wavelength to optical output connector.
Unit does not power up.	C: Insufficient electrical voltage. S: Check that the electrical supply is at least 110 VAC.
	C: AC Power cord is loose. S: Plug power cord is firmly into the unit.
	C: Insufficient electrical voltage. S: Check that the electrical supply is at least 110 VAC.
Unit resets or blinks on and off.	C: Insufficient electrical voltage. S: Check that the electrical supply is at least 110 VAC.

4. Service and Support

Optilab, LLC

600 E. Camelback Road, Phoenix, AZ 85012

Phone: 1-602-343-1496, Fax: (602) 343-1489, Email: sales@oequest.com

4.1 Warranty

Optilab, LLC guarantees its EDFA-PA-L-R unit is guaranteed to be free of defects for 1 year from the date of shipment. The guarantee does not cover any damages resulting from the misuse or improper handling of the equipment, or any incidental or consequential loss. Note that the warranty will be void upon any attempt to open or to fix the equipment by the user without prior approval of Optilab, LLC

4.2 Service and Calibration

Your EDFA-PA-L-R unit has been designed to provide years of trouble-free operation. No internal maintenance is required provided that the equipment is properly handled, operated and kept away from contamination. For any questions regarding the operation and performance of the unit, please contact Optilab, LLC at:

Optilab, LLC
600 E. Camelback Road
Phoenix, AZ 85012

Phone: 1-602-343-1496
Fax: (602) 343-1489
Email: sales@oequest.com

4.3 Care of Fiber-optic Connectors

Damage to optical connectors account for more than 70 percent of equipment performance degradation. To avoid such damage, the user

should use only industrial grade 99% pure isopropyl alcohol and follow the procedures below to keep the connectors, adaptors and receptacles clean.

Cleaning Optical Connector End-face with Wipe and Alcohol

To properly clean optical connectors utilizing lens tissue grade wipes and alcohol follow the procedure below. The moist wipe removes dust particles, oil and contaminants that may damage or blot the end-face of the connector during connection. The dry wipe removes residual alcohol that may be ignited by optical emission.

1. Disable the optical output and turn off unit to prevent accidental exposure or damage to the optical connector by optical emission.
2. Moisten a wipe with alcohol by placing on top of the alcohol dispenser and push down to saturate the wipe.
3. Place the moist wipe on a work surface, and place a second dry wipe next to it.
4. Wipe the optical connector, end-face down on the moist wipe 3 times and then repeat on the dry wipe.
5. Visually inspect the end-face of the optical connector with an optical microscope to verify cleanliness. Repeat steps 2 to 5 as needed.

Cleaning Optical Connector Sides, Receptacles, Adaptors with Swab and Alcohol

Dust or particles can adhere to the insides of receptacles and adaptors or the sides of the optical connector ferrule. Their presence can affect the alignment of the optical fiber connectors and increase connection loss. To properly clean optical connectors, receptacles, and adaptors utilizing a swab and alcohol follow the procedure below:

1. Disable the optical output and turn off unit to prevent accidental exposure or damage to the optical connector by optical emission.
2. Moisten the swab by placing it on top of the alcohol dispenser and push down to saturate the swab.
3. For receptacles, adapters, or other connection points, insert the moistened swab and rotate the tip 1/2 turn clockwise and counter-clockwise 6 times while applying light but firm pressure.
4. For fiber connectors, rotate the tip of the moistened swab 5 revolutions around the connector while applying light but firm pressure.
5. Visually inspect the end face of the connector with an optical microscope to verify cleanliness. Clean end-face as needed.