

# EDFA-PA-L-B USER'S MANUAL

Erbium Doped Fiber Amplifier – Pre-Amp Type, L-Band, Benchtop

**Caution:** The user must read this manual before operating the EDFA-PA-L-B unit. Operations other than those described in this manual may result in personal injury and damage to the unit.

**Note that any attempt to open or fix the equipment without prior approval by Optilab, LLC voids the warranty.**

Ver. 1.1  
Nov.10<sup>th</sup>, 2021



---

# Table of Contents

<b><u>1.</u></b>	<b><u>GENERAL INFORMATION</u></b>	<b><u>1</u></b>
1.1.	INTRODUCTION	1
1.2.	PRODUCT OVERVIEW	1
1.3.	FEATURES	1
1.4.	USER SAFETY	1
<b><u>2.</u></b>	<b><u>OPERATION</u></b>	<b><u>2</u></b>
2.1.	INTRODUCTION	2
2.2.	INITIAL INSPECTION	2
2.3.	CONTROLS	3
	MAIN DISPLAY SCREEN	5
2.4.	OPERATION INSTRUCTIONS	5
	PC CONNECTION MODE (OPTIONAL)	7
<b><u>3.</u></b>	<b><u>TROUBLESHOOTING</u></b>	<b><u>8</u></b>
<b><u>4.</u></b>	<b><u>SERVICE AND SUPPORT</u></b>	<b><u>9</u></b>
4.1.	WARRANTY	9
4.2.	SERVICE AND CALIBRATION	9
4.3.	CARE OF FIBER-OPTIC CONNECTORS	10

## 1. General Information

### 1.1. Introduction

This manual contains information on the installation and operation of the EDFA-PA-L-B benchtop erbium doped fiber amplifier (EDFA) unit.

### 1.2. Product Overview

The EDFA-PA-L-B is an ultra-stable high gain optical amplifier unit designed for applications requiring high efficiency optical amplification. It is a self-contained, benchtop unit designed to supply high and stable gain across the L-Band range of the communications window. The EDFA-PA-L-B is optimized for optical input power from -30 to 0 dBm.

The Optilab EDFA-PA-L-B comes in several output power levels and multiple output ports. Please visit [www.oequest.com](http://www.oequest.com) for more details.

### 1.3. Features

- High saturation output power
- High gain
- High stability
- Low noise
- Low polarization dependence
- Touchscreen and remote interface

### 1.4. User Safety

1. The EDFA-PA-L-B unit emits high intensity invisible light from the optical output receptacle. Avoid direct exposure to skin and eyes.
2. The equipment case is fully certified for EMS protection. The user should never open the equipment case; any attempt will void the warranty and may result in electric shock and EMS attack to equipment in the vicinity.
3. The user should avoid using any solvent or vaporizing chemical to clean the equipment panel or case. It may result in damage to the surface and internal circuits.

## 2. Operation

### 2.1. Introduction

This chapter describes how to operate the EDFA-PA-L-B unit, and discusses the location and function of the controls and connectors.

### 2.2. Initial Inspection

Your EDFA-PA-L-B was carefully inspected before it left the manufacturer. It should be in proper working order upon receipt. You should, however, inspect the unit for any damage that may have occurred in transit. If the shipping container or the packing material is damaged, keep it until the contents of the shipment have been checked to be free of mechanical and electrical damages. Notify Optilab, LLC promptly if any notable damage is found.

## 2.3. Controls

### EDFA-PA-L-B Front Panel



FEATURE	Function
① MAIN DISPLAY	The LED display shows the parameters and optical settings of the EDFA-PA-L-B Benchtop unit. This display is touchscreen with context sensitive buttons for each menu option.
② Laser Enable Switch	This switch enables / disables the laser optical output for the EDFA output.
③ Optical Input and Output Ports	The optical input and output receptacles for the benchtop unit. Multiple output ports are available upon request. The ports shown are FC/APC type.

**An external optical isolator at specified wavelength should be used to protect the EDFA-PA-L-B from optical feedback and to improve stability**

#### **Optilab, LLC**

600 E. Camelback Road, Phoenix, AZ 85012

Phone: (602) 343-1496, Fax: (602) 343-1489, Email: [sales@oequest.com](mailto:sales@oequest.com)

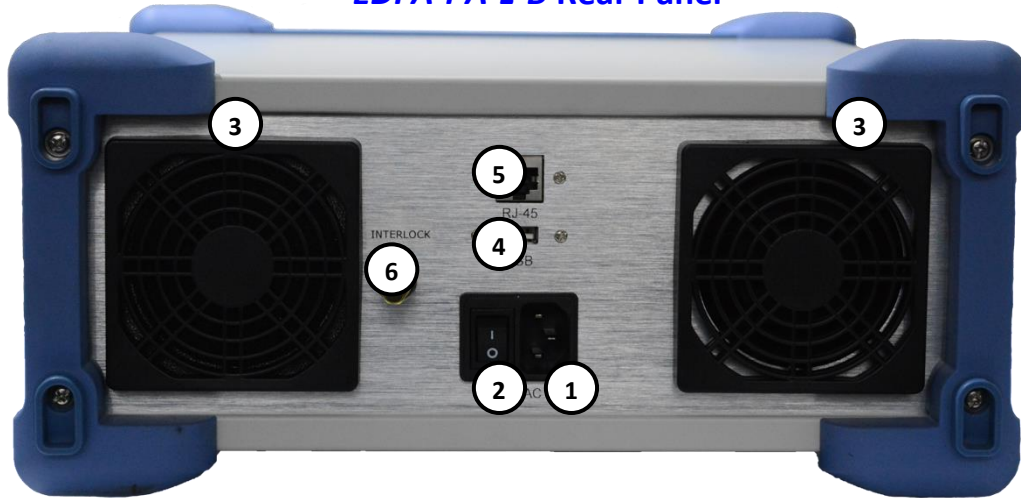
**EDFA-PA-L-B Rear Panel**

FEATURE	Function
① AC Power Socket	The AC power socket is the input for the AC power source. A three-pin standard power cord should be used to connect this equipment to any 110 or 220 V main supply.
② MAIN AC POWER SWITCH	This switch enables the electrical power to the EDFA unit.
③ VENTILATION FANS	The ventilation fans ensure proper ventilation inside the unit. The back panel of this equipment should be placed at least 3 inches from the wall to dissipate heat effectively.
④ USB 2.0 PORT	Using a standard USB cable, this port allows for remote control and monitoring through a PC workstation. <b>This feature is not enabled on all units.</b>
⑤ LAN PORT	This terminal is used allow for Ethernet connection to the EDFA-PA-L-B for remote operation and monitoring. <b>This feature is not enabled on all units.</b>
⑥ INTERLOCK	This BNC female connector is a safety interlock. It must be shorted in order for the pump lasers to enable. Use the provided accessory to short this port or connect it to a compatible interlock device. If the interlock is open during normal operation, the pump lasers will be turned off. To re-enable the pump laser output, after the interlock connection has been re-established, turn the output switch on the front panel to “OFF” position first and start over.

**Optilab, LLC**

600 E. Camelback Road, Phoenix, AZ 85012

Phone: (602) 343-1496, Fax: (602) 343-1489, Email: [sales@oequest.com](mailto:sales@oequest.com)

## Main Display Screen

Upon powering up the EDFA-PA-L-B unit, the Main Display will become lit while the unit initializes. After initialization, the Main Display will appear.

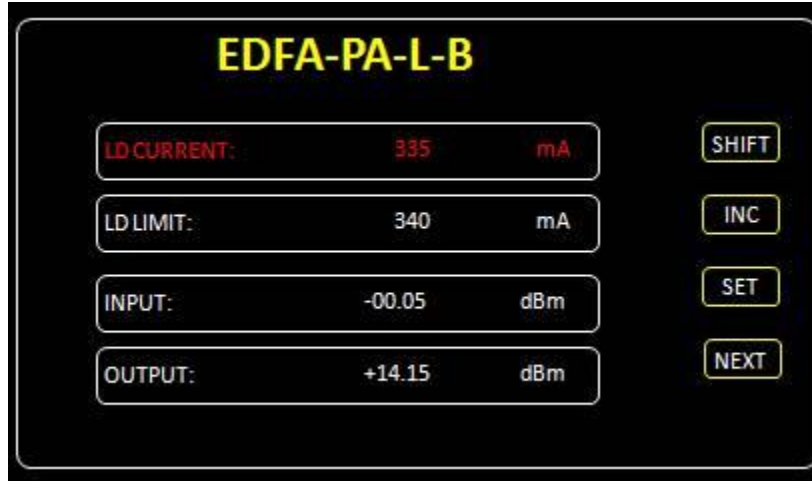

The Main Display allows the user to quickly view the various specifications of the EDFA-PA-L-B. By pressing the Next button, you can proceed to the next page. Follow the onscreen instructions to edit the various parameters.

## 2.4. Operation Instructions

### **Start-up Procedure**

1. After plugging in the appropriate power plug into the AC Power Socket, flip the main switch to the On position to enable electrical power to the unit. The LCD display will turn on.
2. Wait for the LCD display to switch to the Main Display / Status screen.
3. Ensuring the input signal is turned off, connect the optical signal for amplification via the optical input receptacle using the indicated connector patchcords.
4. Connect the optical output receptacle using the indicated connector patchcords to the appropriate signal destination to utilize the amplified optical output signal(s).
5. After checking all physical patchcord connections, turn the input signal laser source on.
6. Turn the front panel Laser Enable Switch to the On position.
7. The EDFA-PA-L-B is now enabled. The laser output will then be activated, as indicated by the Main Display Output Power monitor value.



### Optical Output Adjustment Procedure

1. To adjust the optical output level for the EDFA-PA-L-B, press the SHIFT touchscreen button to toggle cursor placement followed by pressing the INC button to increase cursor placement value.



2. Press the SET button to allow adjustment to the current, observing the noted LD Limit.
3. In addition to this current adjustment feature, pressing the Next button will allow for viewing the system information, as seen below:

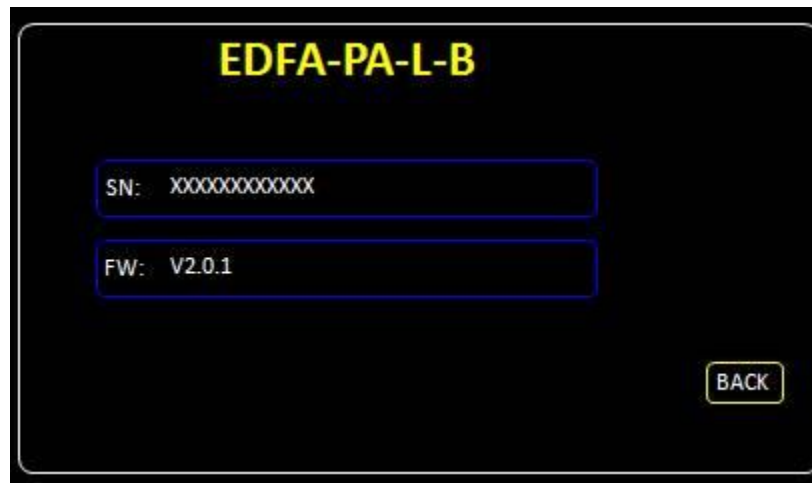

## PC Connection Mode (OPTIONAL)

1. Connect the EDFA-PA-L-B to computer via a standard USB 2.0 cable, and refer to the following connection diagram and serial port settings:

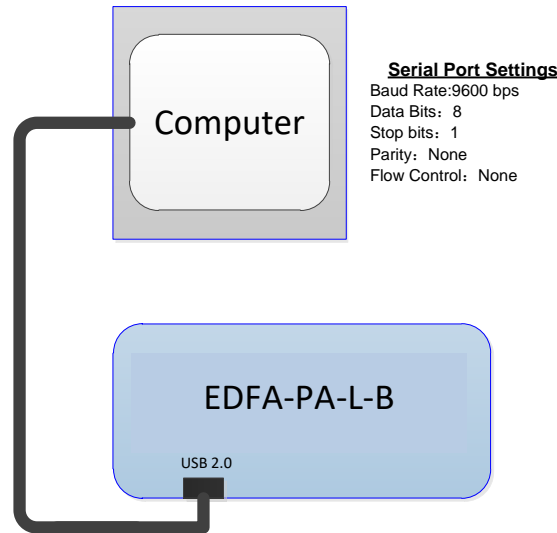

3. Using the computer program Device Manager, determine the appropriate COMport to assign in the RS232 software, to ensure proper communication to the EDFA-PA-L-B unit.
2. Use the RS232 commands to control the EDFA-PA-L-B remotely. The RS232 commands are listed in the table below.

Command	Description	Example
READ	Reads the basic parameters of the device for remote monitoring	READ
SETC	Set the desired driving current level, in mA (requires three digits, leading zero required if transmitting two digit value. The setting range is 000 to 270, which is the default current limit setting	SETC:100 SETC:050 SETC:270

### Optilab, LLC

600 E. Camelback Road, Phoenix, AZ 85012

Phone: (602) 343-1496, Fax: (602) 343-1489, Email: [sales@oequest.com](mailto:sales@oequest.com)

## Troubleshooting

SYMPTOM	Possible Cause and Solution
OPTICAL OUTPUT POWER NOT HIGH ENOUGH.	<b>C:</b> No optical input or optical input power too small. <b>S:</b> Check optical input present or check optical input power is correct.
	<b>C:</b> Optical input/output connectors dirty. <b>S:</b> Disable optical output and clean optical connectors.
	<b>C:</b> Use of incorrect optical adapters or connectors. <b>S:</b> Use only the indicated optical adapters and connectors. If measurement instruments accept different connector type, then use hybrid patchcords.
	<b>C:</b> Optical output connector damaged. <b>S:</b> Measure optical output power with power meter and compare with readout on Main Display. Return to Optilab for repair if the difference is high (>4 dB) and cannot be corrected by cleaning or replacing the optical connectors. Always apply dust cover plugs to unused optical receptacles to prevent the damage of internal optical connectors.
	<b>C:</b> Static electrical discharge. <b>S:</b> Wait 10 to 30 seconds for the display to refresh.
MAIN DISPLAY GOES BLANK	<b>C:</b> Insufficient ventilation. <b>S:</b> Place unit in well ventilated area or supply additional fans for ventilation.
OPTICAL OUTPUT POWER UNSTABLE.	<b>C:</b> Insufficient optical output isolation. <b>S:</b> Connect isolator of corresponding wavelength to optical output connector.
UNIT DOES NOT POWER UP.	<b>C:</b> Blown fuse. <b>S:</b> Check fuse and replace if it has blown.
	<b>C:</b> Insufficient electrical voltage. <b>S:</b> Check that the electrical supply is at least 110 VAC.
	<b>C:</b> Power cord is loose. <b>S:</b> Plug power cord is firmly into the unit.
UNIT RESETS OR BLINKS ON AND OFF.	<b>C:</b> Insufficient electrical voltage. <b>S:</b> Check that the electrical supply is at least 110 VAC.

### **Optilab, LLC**

600 E. Camelback Road, Phoenix, AZ 85012

Phone: (602) 343-1496, Fax: (602) 343-1489, Email: [sales@oequest.com](mailto:sales@oequest.com)

## 3. Service and Support

### 3.1. Warranty

Optilab, LLC guarantees its EDFA-PA-L-B unit is guaranteed to be free of defects for 1 year from the date of shipment. The guarantee does not cover any damages resulting from the misuse or improper handling of the equipment, or any incidental or consequential loss. Note that the warranty will be void upon any attempt to open or to fix the equipment by the user without prior approval of Optilab, LLC

### 3.2. Service and Calibration

Your EDFA-PA-L-B unit has been designed to provide years of trouble-free operation. No internal maintenance is required provided that the equipment is properly handled, operated and kept away from contamination. For any questions regarding the operation and performance of the unit, please contact Optilab, LLC at:

Optilab, LLC  
600 E. Camelback Road  
Phoenix, AZ 85012

Phone: (602) 343-1496  
Fax: (602) 343-1489  
Email: [sales@oequest.com](mailto:sales@oequest.com)

### 3.3. Care of Fiber-optic Connectors

Damage to optical connectors account for more than 70 percent of equipment performance degradation. To avoid such damage, the user should use only industrial grade 99% pure isopropyl alcohol and follow the procedures below to keep the connectors, adaptors and receptacles clean.

#### **Cleaning Optical Connector End-face with Wipe and Alcohol**

To properly clean optical connectors utilizing lens tissue grade wipes and alcohol follow the procedure below. The moist wipe removes dust particles, oil and contaminants that may damage or blot the end-face of the connector during connection. The dry wipe removes residual alcohol that may be ignited by optical emission.

1. Disable the optical output and turn off unit to prevent accidental exposure or damage to the optical connector by optical emission.
2. Moisten a wipe with alcohol by placing on top of the alcohol dispenser and push down to saturate the wipe.
3. Place the moist wipe on a work surface, and place a second dry wipe next to it.
4. Wipe the optical connector, end-face down on the moist wipe 3 times and then repeat on the dry wipe.
5. Visually inspect the end-face of the optical connector with an optical microscope to verify cleanliness. Repeat steps 2 to 5 as needed.

#### **Cleaning Optical Connector Sides, Receptacles, Adaptors with Swab and Alcohol**

Dust or particles can adhere to the insides of receptacles and adaptors or the sides of the optical connector ferrule. Their presence can affect the alignment of the optical fiber connectors and increase connection loss. To properly clean optical connectors, receptacles, and adaptors utilizing a swab and alcohol follow the procedure below:

1. Disable the optical output and turn off unit to prevent accidental exposure or damage to the optical connector by optical emission.
2. Moisten the swab by placing it on top of the alcohol dispenser and push down to saturate the swab.
3. For receptacles, adapters, or other connection points, insert the moistened swab and rotate the tip 1/2 turn clockwise and counter-clockwise 6 times while applying light but firm pressure.
4. For fiber connectors, rotate the tip of the moistened swab 5 revolutions around the connector while applying light but firm pressure.
5. Visually inspect the end face of the connector with an optical microscope to verify cleanliness. Clean end-face as needed.