

ASE-C-MSA Series User's Manual

ASE Source Module in MSA Footprint

Caution: The user must read this manual before operating the ASE-C-MSA unit. Operations other than those described in this manual may result in personal injury and damage to the unit.

Note that any attempt to open or fix the equipment without prior approval by Optilab, LLC. voids the warranty.

Ver. 1.0
Oct 28th, 2021

Table of Contents

1. GENERAL INFORMATION	1
1.1 INTRODUCTION	1
1.2 PRODUCT OVERVIEW	1
1.3 FEATURES	1
1.4 USER SAFETY	1
2. OPERATION	2
2.1 INTRODUCTION	2
2.2 INITIAL INSPECTION	2
2.3 PANEL DIAGRAM AND CONTROLS	2
2.4 PIN-OUT DIAGRAM	4
2.5 OPERATION INSTRUCTIONS	5
2.6 PC CONNECTION MODE	6
2.7 REMOTE CONTROL COMMAND SET	7
2.8 MECHANICAL DRAWING	7
3. TROUBLESHOOTING	8
4. SERVICE AND SUPPORT	9
4.1 WARRANTY	9
4.2 SERVICE AND CALIBRATION	9
4.3 CARE OF FIBER-OPTIC CONNECTORS	9

1. General Information

1.1 Introduction

This manual contains information on the installation and operation of the ASE-C-MSA series ASE source module in MSA footprint.

1.2 Product Overview

The Optilab ASE-C-MSA is an Amplified Spontaneous Emission (ASE) based broadband light source in a multi-source agreement (MSA) footprint module. It is available in single output channel or 3 output channels version. The ASE-C-MSA is a reliable and cost-effective module with one or three output channels. The optical output of each channel can be as high as 14 dBm. The LD operating temperature and drive current are precisely monitored by a micro-controller to ensure constant output power and emission wavelength stability. The module can be controlled through a computer by using a USB or RS-232 interface, the user can control the ASE source output power level by setting the pump driving current. Contact Optilab for more information.

1.3 Features

- Emission wavelength 1527 nm – 1565 nm
- 3 channel outputs with 14 dBm maximum output power for each channel
- Minimal ripple in emission spectrum
- Monitoring and control via USB or RS232 interfaces

1.4 User Safety

1. The ASE-C-MSA module emits high intensity invisible light from the optical output receptacle. Avoid direct exposure to skin and eyes.
2. The module case is fully certified for EMS protection. The user should never open the module case; any attempt will void the warranty and may result in electric shock and EMS attack to equipment in the vicinity.
3. The user should avoid using any solvent or vaporizing chemical to clean the exterior. It may result in damage to the surface and internal circuits.

2. Operation

2.1 Introduction

This chapter describes how to operate the ASE-C-MSA unit and introduce the location and function of the controls and connectors.

2.2 Initial Inspection

Your ASE-C-MSA was carefully inspected before it left the manufacturer. It should be in proper working order upon receipt. You should, however, inspect the unit for any damage that may have occurred in transit. If the shipping container or the packing material is damaged, keep it until the contents of the shipment have been checked to be free of mechanical and electrical damages. Notify Optilab, LLC promptly if any notable damage is found.

2.3 Panel Diagram and Controls

ASE-C-MSA



FEATURE	FUNCTION
① ELECTRICAL CONNECTION PORT, 30 PIN	This port is used to connect the ASE module to the Power Adaptor. It is a 30-pin type connector, with the full pin-out diagram is shown in section 2.4 of this manual
② MODEL AND SERIAL NUMBER LABEL	This label shows the model number and serial number of the device.
③ OPTICAL OUTPUT FIBER PORTS	The optical output fiber ports for the ASE module. The fiber ports shown are FC/APC type.

Power Adapter – Cable Assembly

Optilab provide two types of power adapters options to interface with ASE-C-MSA module. These adapters are optional to use. They are designed for users with little experience using modules to plug and play. The main difference of the two types of adapters lies in the power supply form. Option 1 uses a 4-Pin Molex connector, which is compatible with Optilab PM-5-M +/-5V power supply module. Option 2 uses a single +5V power jack connector.

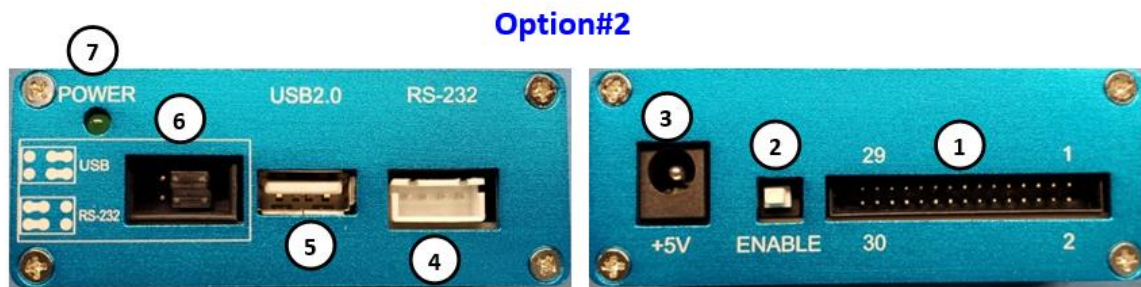
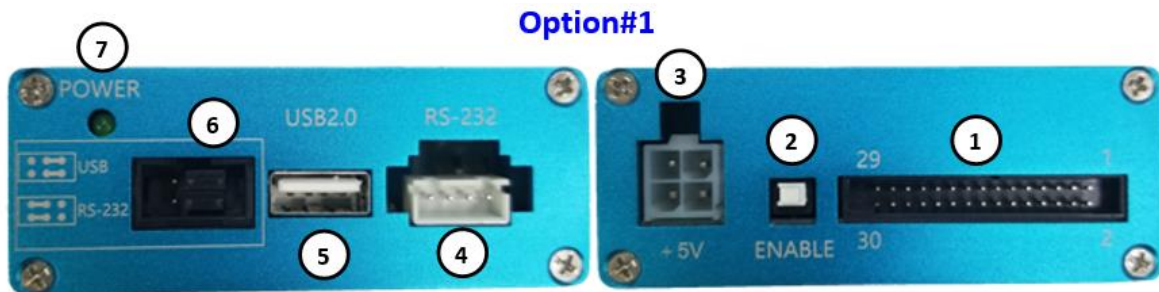

FEATURE	FUNCTION
① ASE MODULE CONNECTOR PORT, 30 PIN	This port is used to connect the power adaptor to the ASE module for operation. It is a 30-pin connector.
② POWER SWITCH	This power Switch turns on/off the electrical power to the ASE module
③ DC POWER SOCKET	The DC power socket is connected to a +5 VDC power supply. <u>Option#1:</u> 4-pin socket DC power supply is needed, the pin diagram is shown in section 2.4 of this manual. Optilab PS-5-M which outputs +5V can be a candidate power supply. <u>Option#2:</u>

	A typical coaxial AC/DC power adaptor with output of +5V (3000 mA) is needed for powering the power adaptor.
④ RS232 PORT	Using a RS232 port, this cable allows for remote control and monitoring through a PC workstation. User can choose between using either USB or RS232. The pin-out diagram is shown in section 2.4 of this manual.
⑤ USB PORT	Using a USB port, this cable allows for remote control and monitoring through a PC workstation. User can choose between using either USB or RS232.
⑥ INTERFACE SELECTOR	This 3-pin jumper pairs can be connected correspondingly to enable USB interface or RS-232 interface.
⑦ LED INDICATOR FOR MODULE POWER	Display for power state of the adaptor. The LED lights green when the power adaptor is powered on.

2.4 Pin-Out Diagram

30-pin cable pin-out diagram

Listed below is the pin-out diagram for the 30-pin port on the external of the ASE-C-MSA module and power adaptor:

+5V	30	29	+5V
NC	28	27	NC
GND	26	25	GND
NC	24	23	NC
GND	22	21	GND
NC	20	19	NC
NC	18	17	NC
NC	16	15	NC
NC	14	13	KEY
NC	12	11	NC
GND	10	9	GND
TX	8	7	RX
GND	6	5	GND
NC	4	3	NC
+5V	2	1	+5V

Pins 1, 2, 29, 30 – +5 VDC. It is important to have all pins connected for proper operation.

Pins 5, 6, 9,10,21,22,25, 26 – Ground

Pin 7 – RS232 RX, for receiving data via standard serial communication, TTL Format.

Pin 8– RS232 TX, for transmitting data via standard serial communication, TTL Format.

Pin 13 – Enable, short this pin to GND to enable the internal power Power.

All other Pins – Not Connected

+5V power socket pin-out diagram

Listed below is the pin-out diagram for the +5V 4-pin power socket on the external of the power adapter:

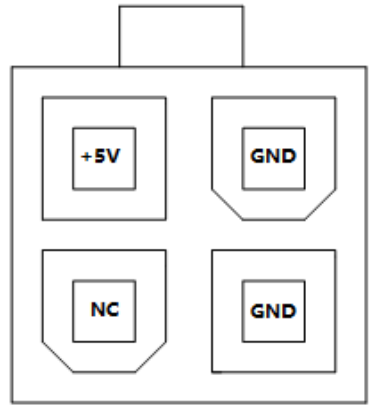

RS-232 pin-out diagram

Listed below is the pin-out diagram for the RS-232 port on the external of the power adapter



2.5 Operation Instructions

Start-up Procedure

1. Make sure the three optical output FC/APC connectors of the ASE module are properly connected to the optical power receiver.
2. Connect the ASE module to the power adapter by using the 30-pin cable.
3. Connect the power adaptor to a +5 V DC power supply (depends on the power adaptor the customer received, the Optilab PS-5-M power supply or a typical coaxial +5 VDC AC/DC adaptor can be used) through DC power socket.

Optilab, LLC

600 E. Camelback Road, Phoenix, AZ 85012

Phone: (602) 343-1496, Fax: (602) 343-1489, Email: sales@oequest.com

4. Connect the power adapter to a PC for remote control by using an USB cable or RS-232 cable.
5. After checking all physical patch cord connections, turn on the +5 V power supplier, the electrical power is applied to the power adapter, the LED indicator on the power adapter turns green.
6. Press the power switch on the power adapter to enable the electrical power driving of the ASE module. Now the ASE module is ON, and the laser current can be adjusted using the PC.

Turn-off Procedure

1. Set the pump current to be zero to turn off the laser.
2. Exit and close the command setting window of the module.
3. Press the power switch on the power adaptor to turn off the electrical power applied on the ASE module.
4. Turn off the +5V power supply.

2.6 PC Connection Mode

For the standard ASE-C-MSA, connecting the ASE module to an external PC will allow for parameter monitoring and pump current adjustments. If you have an ASE-C-MSA with additional software control, please refer to the additional supplemental manual for complete information.

Using the USB port (or RS-232 cable) on the cable assembly, connect the ASE module to a PC using the following connection diagram and serial port settings:

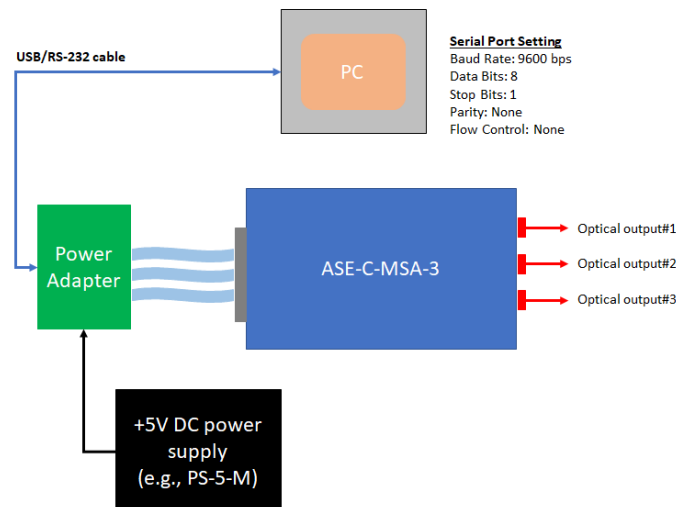

2.7 Remote Control Command Set

When the electrical connections have been made, and the software settings for serial port transmission are set correctly, you are now able to send commands to the ASE module. The commands are listed below:

Command	Description	Example	Response
READ	Reads the equipment basic information.	READ{CR,LF}	Optilab,LLC. Model Type:ASE-C-MSA-3 SN:XXXXXXXX Version:VX.XX PUMP Current:000 Protect Current:600 Output1:Low Output2:Low Output3:Low
SETC	Set the pump laser current. The current can be set between 0 mA and the protect current (600 mA typically).	SETC:050{CR,LF} Set the pump current to be 50 mA.	PUMP Current:050

2.8 Mechanical Drawing

Unit: mm

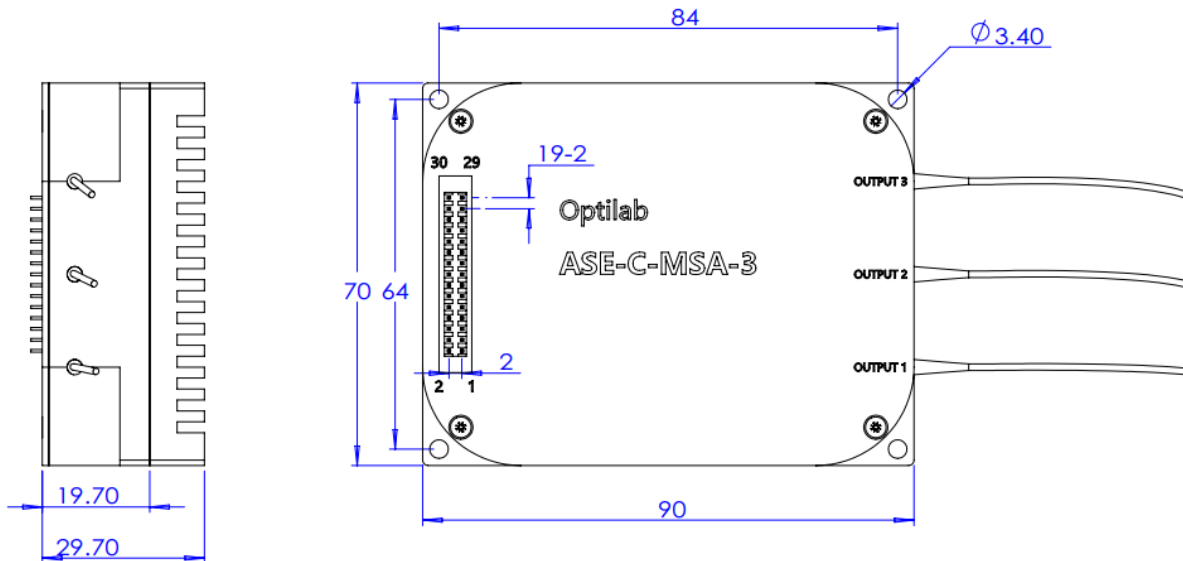

Detachable Heat Sink:

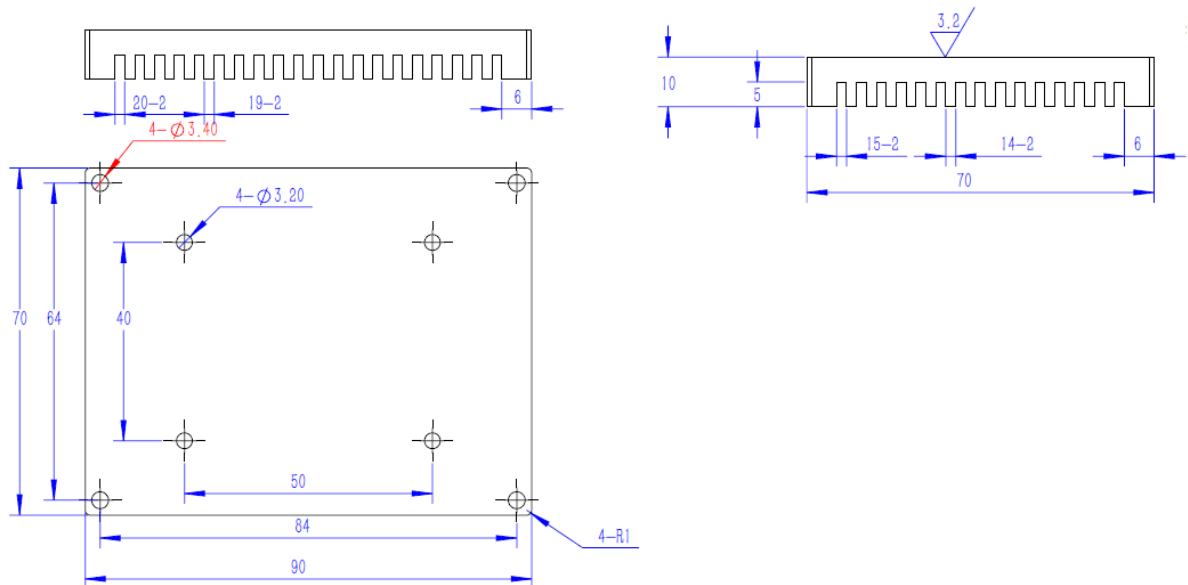

3. Troubleshooting

SYMPTOM	POSSIBLE CAUSE AND SOLUTION
<p>OPTICAL OUTPUT POWER NOT HIGH ENOUGH.</p>	<p>C: No optical input or optical input power too small. S: Check optical input present or check optical input power is correct.</p>
	<p>C: Optical input/output connectors dirty. S: Disable optical output and clean optical connectors.</p>
	<p>C: Use of incorrect optical adapters or connectors. S: Use only the indicated optical adapters and connectors. If measurement instruments accept different connector type, then use hybrid patchcords.</p>
	<p>C: Optical output connector damaged. S: Measure optical output power with power meter and compare with readout on PC connection 'READ' command. Return to Optilab for repair if the difference is high (>4 dB) and cannot be corrected by cleaning or replacing the optical connectors. Always apply dust cover plugs to unused optical ports to prevent the damage of optical connectors.</p>
	<p>C: Improper pin connections S: If directly connecting the voltage to the 30 pin connector, ensure that all +5 VDC pins are making adequate contact to your supply.</p>

ASE MODULE IS OVERHEATING	<p>C: Insufficient ventilation / heat dissipation. S: Place unit in well-ventilated area or supply additional fans for ventilation. You may need to add a heat sink for additional heat dissipation.</p>
OPTICAL OUTPUT POWER UNSTABLE.	<p>C: Insufficient optical output isolation. S: Connect isolator of corresponding wavelength to optical output connector.</p>
UNIT DOES NOT POWER UP.	<p>C: Improper pin connections S: If directly connecting the voltage to the 30 pin connector, ensure that all +5 VDC pins are making adequate contact to your supply.</p>
	<p>C: AC Power cord is loose. S: Plug power cord is firmly into the unit.</p>

4. Service and Support

4.1 Warranty

Optilab, LLC guarantees its ASE-C-MSA module is guaranteed to be free of defects for 1 year from the date of shipment. The guarantee does not cover any damages resulting from the misuse or improper handling of the equipment, or any incidental or consequential loss. Note that the warranty will be void upon any attempt to open or to fix the equipment by the user without prior approval of Optilab, LLC

4.2 Service and Calibration

Your ASE-C-MSA module has been designed to provide years of trouble-free operation. No internal maintenance is required provided that the equipment is properly handled, operated, and kept away from contamination. For any questions regarding the operation and performance of the unit, please contact Optilab, LLC at:

Optilab, LLC
600 E. Camelback Road
Phoenix, AZ 85012

Phone: (602) 343-1496
Fax: (602) 343-1489
Email: sales@oequest.com

4.3 Care of Fiber-optic Connectors

Damage to optical connectors account for more than 70 percent of equipment performance degradation. To avoid such damage, the user should use only

Optilab, LLC

600 E. Camelback Road, Phoenix, AZ 85012

Phone: (602) 343-1496, Fax: (602) 343-1489, Email: sales@oequest.com

industrial grade 99% pure isopropyl alcohol and follow the procedures below to keep the connectors, adaptors and receptacles clean.

Cleaning Optical Connector End-face with Wipe and Alcohol

To properly clean optical connectors utilizing lens tissue grade wipes and alcohol follow the procedure below. The moist wipe removes dust particles, oil and contaminants that may damage or blot the end-face of the connector during connection. The dry wipe removes residual alcohol that may be ignited by optical emission.

1. Disable the optical output and turn off unit to prevent accidental exposure or damage to the optical connector by optical emission.
2. Moisten a wipe with alcohol by placing on top of the alcohol dispenser and push down to saturate the wipe.
3. Place the moist wipe on a work surface, and place a second dry wipe next to it.
4. Wipe the optical connector, end-face down on the moist wipe 3 times and then repeat on the dry wipe.
5. Visually inspect the end-face of the optical connector with an optical microscope to verify cleanliness. Repeat steps 2 to 5 as needed.

Cleaning Optical Connector Sides, Receptacles, Adaptors with Swab and Alcohol

Dust or particles can adhere to the insides of receptacles and adaptors or the sides of the optical connector ferrule. Their presence can affect the alignment of the optical fiber connectors and increase connection loss. To properly clean optical connectors, receptacles, and adaptors utilizing a swab and alcohol follow the procedure below:

1. Disable the optical output and turn off unit to prevent accidental exposure or damage to the optical connector by optical emission.
2. Moisten the swab by placing it on top of the alcohol dispenser and push down to saturate the swab.
3. For receptacles, adapters, or other connection points, insert the moistened swab and rotate the tip 1/2 turn clockwise and counter-clockwise 6 times while applying light but firm pressure.
4. For fiber connectors, rotate the tip of the moistened swab 5 revolutions around the connector while applying light but firm pressure.
5. Visually inspect the end face of the connector with an optical microscope to verify cleanliness. Clean end-face as needed.