

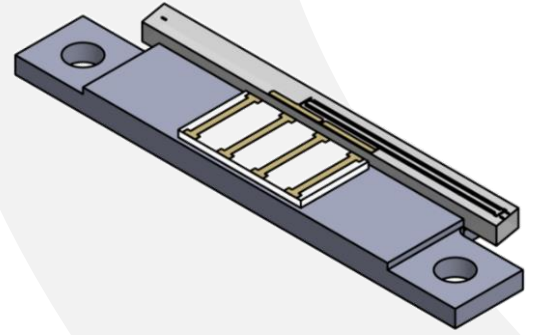

MIOC-1550-22-SB



DEVICE

Multi-functional Integrated Optical Chip 1550 nm, 22 mm Chip on a Submount

OVERVIEW

The Optilab MIOC-1550-22-BC is the optical chip of Fiber Optic Gyroscope (FOG) for rotational rate sensing and inertial navigation systems. This Integrated Optic Chip (IOC) device is composed of a polarizer, a Y-junction coupler and dual electro optic phase modulators. Based on Lithium Niobate (LiNbO3), MIOC-1550-22-BC is fabricated with Annealed Proton Exchange (APE) optical waveguides. The MIOC-1550-22-BC features Polarization Extinction Ratio (PER) exceeding 60 dB. The MIOC-1550-18-BC assures high reliability and performance over wide temperature range and is compatible with a variety of PM fibers. Contact Optilab for more information.

FEATURES

- 1550 ± 20 nm operation
- Low insertion loss
- Polarization extinction ratio > 60 dB
- Low V_{π} voltage
- Low Polarization crosstalk
- PM fiber pigtailed

USE IN

- Fiber Optic Gyroscope (FOG)
- Fiber Optic Current Sensor (FOCS)
- Hydrophone and other optic sensitive fields
- Research and development

FUNCTIONAL DIAGRAM

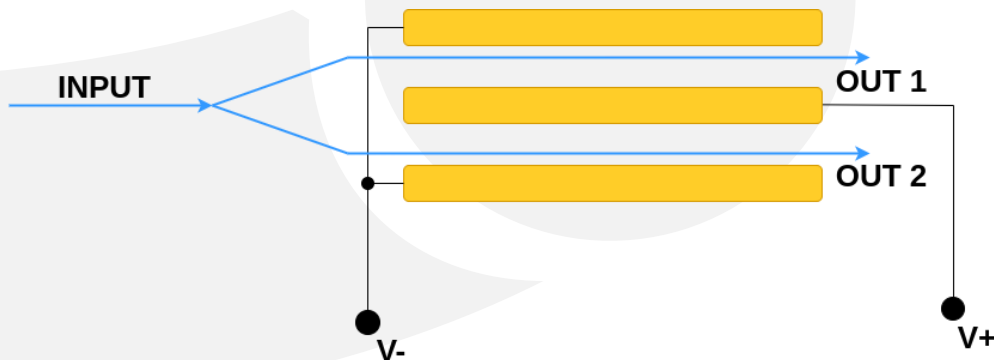



MIOC-1550-22-SB

ABSOLUTE MAXIMUM RATING ($T_c = 25\text{ }^\circ\text{C}$ unless otherwise specified)

Parameter	Symbol	Conditions	Min	Max	Unit
Optical Input Power	OP_{in}	CW		100	mW
Drive Voltage	V_{in}	CW or Pulse	-25	+25	V
Operation Case Temperature	T_c		-45	75	$^\circ\text{C}$
Storage Temperature	T_{st}		-45	85	$^\circ\text{C}$

GENERAL SPECIFICATIONS at Room Temperature ($T_c = 25\text{ }^\circ\text{C}$)

Parameter	Symbol	Unit	P Grade	A Grade	B Grade
Operating Wavelength	λ	nm	1520 ~ 1570		
Insertion Loss	IL	dB	≤ 2.5	≤ 3.0	≤ 3.5
Splitting Ratio	SR	%	50 ± 2	50 ± 3	50 ± 5
Half Wave Voltage	V_{pi}	V	≤ 4.0	≤ 4.1	≤ 4.3
Chip Polarization Extinction Ratio	PER	dB	≥ 60		
Residual Intensity Modulator	RIM	%	≤ 0.1	≤ 0.1	≤ 0.2
Chip Length	L	mm	18.0 +/- 0.1		
Waveguide Separation Distance	G	μm	400 +/- 1		
End facet Polish Angle	α	degree	10 +/- 0.3		

Ordering Option:

MIOC-1550-LL-FF-G-XX-YY-ZZ

LL: Chip Length

- 18: 18 mm
- 22: 22 mm

FF: Form Factor

- BC: Bare chip
- SB: Bare chip on submount
- SP: Fiber pigtailed w/ submount
- PG: Packaged

G: Grade

- P: Premium grade
- A: A grade
- B: B grade

XX: Input Fiber

- YY: Output Fiber #1
- ZZ: Output Fiber #2

For each fiber:

First digit: Fiber Type

Second digit: Alignment direction

Fiber Type Option:

- 0: No fiber pigtail
- 1: Corning RCPM15, 80/165 μm
- 2: Corning PM15-U25D, 125/250 μm

Fiber Alignment Direction Option:

- 0: Not applicable
- 1: Slow axis aligned to TE mode
- 2: Fast axis aligned to TE mode
- 3: 45° alignment

