

LTB-50



DEVICE

50 GHz Lightwave Transmitter Board for OEM

OVERVIEW

The Optilab LTB-50 is a high performance Lightwave Transmitter Board designed for analog photonics applications from DC to 50 GHz. This unit includes a 50 GHz optical intensity modulator and an Automatic Bias Control (ABC) board with four different operating modes. The integrated internal DFB laser makes it a versatile solution for RFoF system integration. The LTB-50 requires a single ± 5 Volt DC power supply for operation. Contact Optilab for more information.

FEATURES

- 1520 nm to 1610 nm wavelength range
- Automatic Bias Control w/ 4 mode operation
- Internal DFB Laser up to 50 mW
- Customizable Options:
 - Low Drive Voltage
 - PM Output
 - High Extinction Ratio (>30 dB)

USE IN

- Satellite communication
- Optical Communications to 43 Gb/s
- Sub-nanosecond pulse generation
- Analog photonics
- 43 GHz RFoF transmission
- RF/IF signal distribution

FUNCTIONAL DIAGRAM

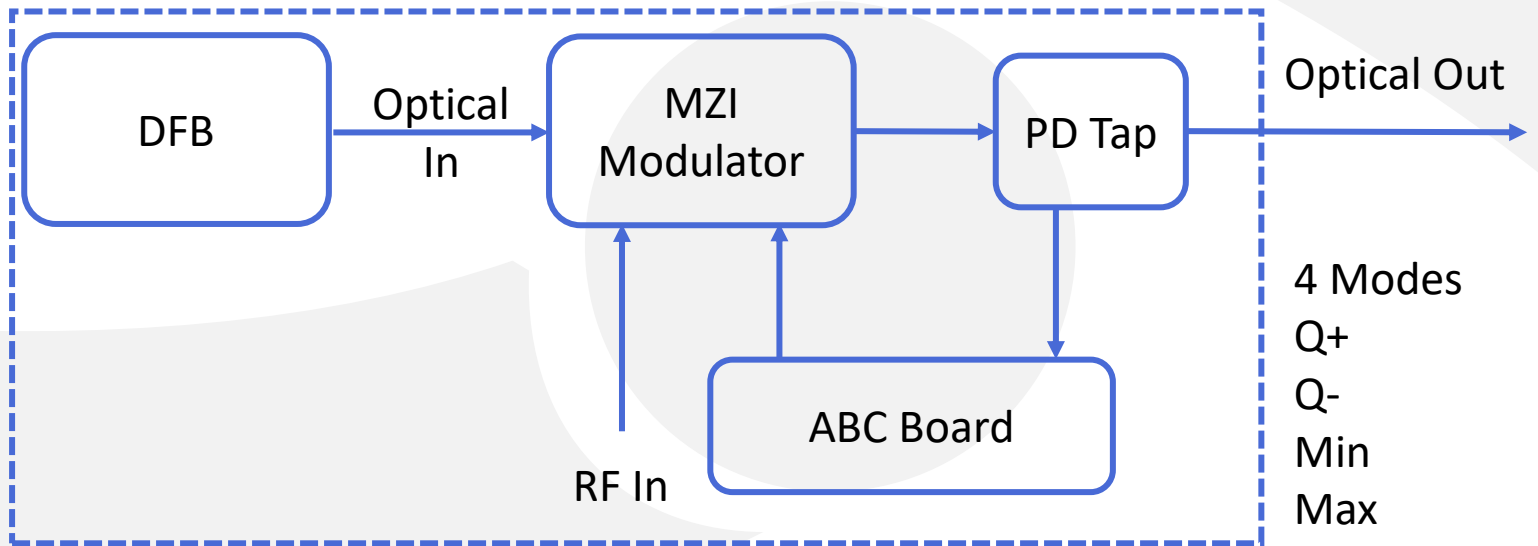



LTB-50

SPECIFICATIONS

Operating Wavelength	1520 nm to 1610 nm
Laser Source	Internal DFB laser, 1550 ± 10 nm; other wavelength and narrow linewidth < 1 MHz are available
Laser Power Level	20 mW, 30 mW, 40 mW, 50 mW
RF Return Loss	≤ -10 dB @ 20 GHz
Impedance	50 Ω
Operating Frequency Range	DC to 50 GHz
Input RF Voltage	27 dBm max.
Optical Output Level	6.5 dBm typ. With 20 mW DFB
S21 Bandwidth	29 GHz typ. @ -3 dB, 51 GHz typ. @ -6 dB
Modulator Bias Mode	4 Automatic bias control modes, selectable by software
Extinction Ratio	25 dB typ., > 30 dB (HE version)
Modulator Voltage V_{PI}	3 V typ. @ 10 GHz typ

GENERAL

Operating Temperature (standard)	-30°C to +60°C
Storage Temperature	-60°C to +90°C
Power Supply Requirements	± 5 V, 1 A typ.
Optical Connectors	FC/APC
Fiber Type	SMF-28 output, PANDA output (PM version)
RF Input Connector	V connector
Power Connector	4 Pin Molex
Remote Control	USB 2.0 software included
Dimensions	206mm x 102.4mm x 31.5mm

MECHANICAL

Q+	Set to quadrature point of positive slope for linear analog modulation
Q-	Set to quadrature point of negative slope for linear analog modulation
Min	Set to min. point of operation for pulse generator or digital modulation
Max	Set to max. point of operation for pulse generator or digital modulation

BIAS CONTROL MODE





LTB-50

TYPICAL S21 AND S22 BANDWIDTH

S21

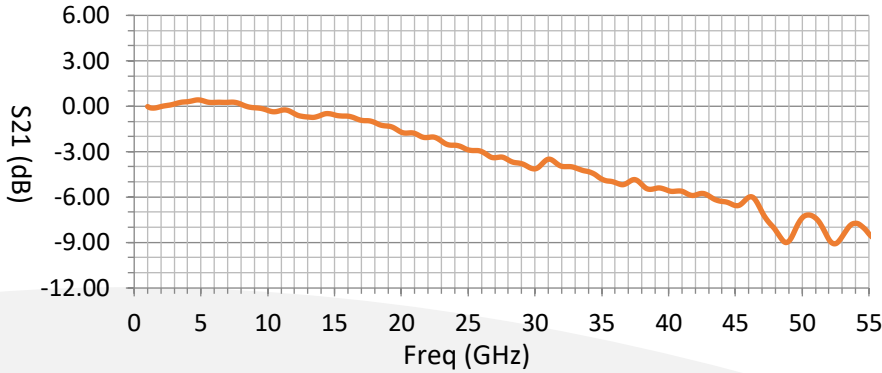

S11

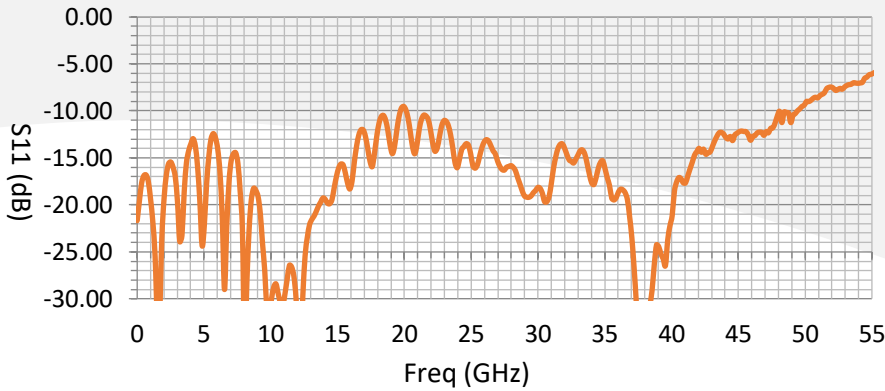

OPTIONS

LTB-50-XX

- LD: Low Drive Voltage
- XX: PM: Polarization Maintaining
- HE: High Extinction Ratio

BIAS SETTING MODES FOR LTB

Based on sophisticated phase measurement of this small dither signal, LTB-50 provides four selectable operating modes: quadrature (Quad +), inverted quadrature (Quad-), minimum (Min), or maximum (Max) points.

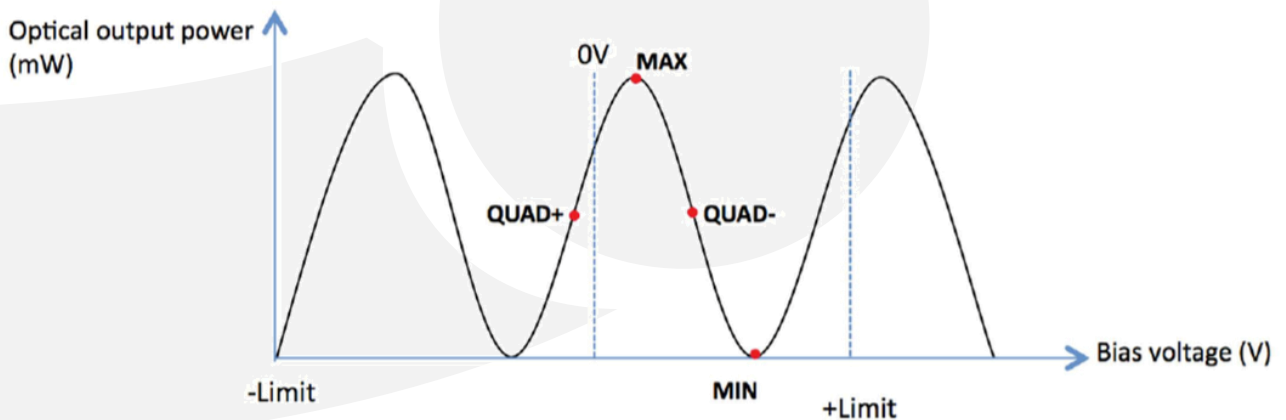

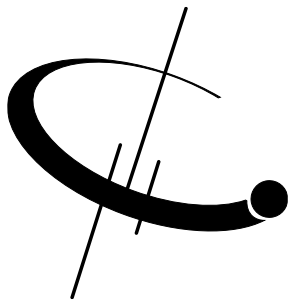

LTB-50

DETAILED LAYOUT

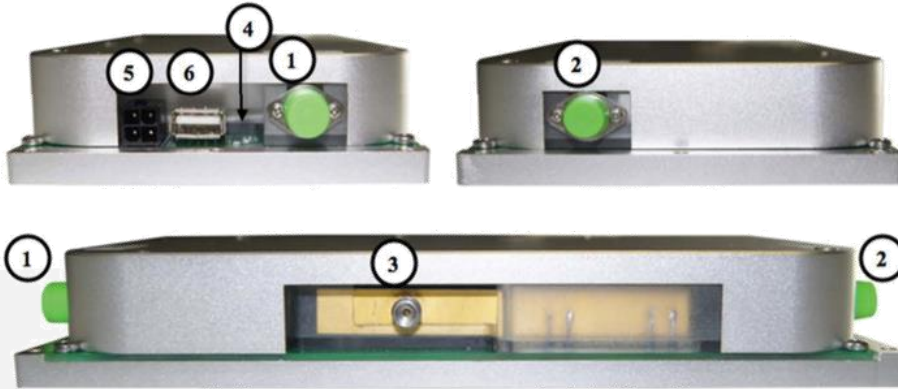

No.	Feature
1	NC
2	Optical Output Port
3	RF Input Port
4	LED Indicators
5	DC Connection Port
6	USB Control and Monitor Port

MECHANICAL DRAWING

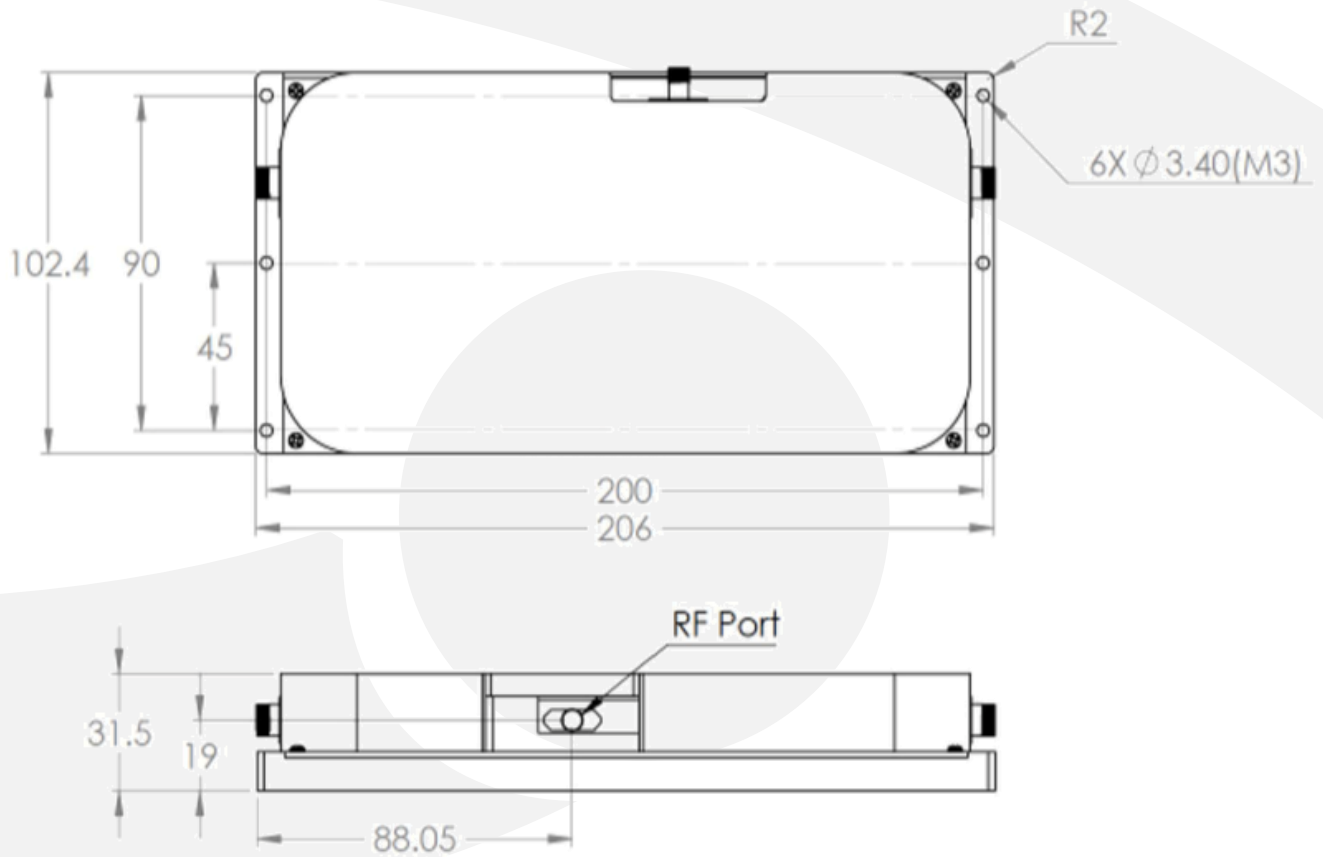

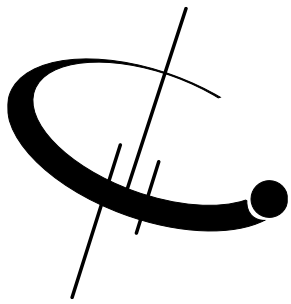

LTB-50

PRECISION POWER SUPPLY FOR LTB (OPTIONAL)

FRONT



BACK



General Specifications	
Parameters	Specifications
Input AC Voltage (VAC)	85-240
Input AC Current (A)	≤0.5
Input AC Frequency (HZ)	50-60
Transfer Efficiency	≤85%
DC Output Current (A)	4 A max.
DC Output Voltage (V)	±5 V
DC Voltage Ripple	≤2%
DC Connectors	Molex 4 Pin
Communication Connectors	DB-9 and USB 2.0
Dimensions (mm)	153x115x33

