

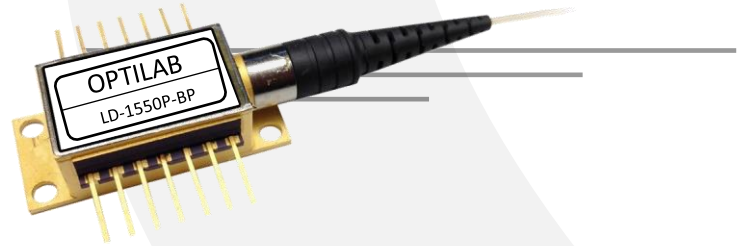

LD-1550P-BP



DEVICE **1550 nm Fabry Perot Laser Diode, 20 mW CW, 50mW Peak Power**

OVERVIEW The Optilab LD-1550P-BP is a high power Fabry-Perot (FP) laser diode with a 1550 nm wavelength. The LD-1550P-BP incorporates a strained multi-quantum (st-MQW) laser diode chip with thermo-electric cooler (TEC), a PIN photodiode, and PM output fiber, in a hermetically sealed 14-pin butterfly package. It can be used for both CW and Pulse mode. Also, the laser is designed for laboratory test application that requires short coherence laser. Contact Optilab for more information.

- FEATURES
- 20 mW output power
 - 50 mW Peak Power
 - Used for both CW & Pulse
 - Short Coherence Length
 - PM Fiber Output available
 - Built in TEC, Thermistor & Monitor PD

- USE IN
- Interferometer
 - Fiber Sensors
 - Multi-mode laser source
 - General laboratory and research use

FUNCTIONAL DIAGRAM

PIN	Description	PIN	Description
1	TEC(+)	8	NC
2	Thermistor	9	NC
3	Detector(P)	10	LD(P)
4	Detector(N)	11	LD(N)
5	Thermistor	12	NC
6	NC	13	Ground
7	NC	14	TEC(-)

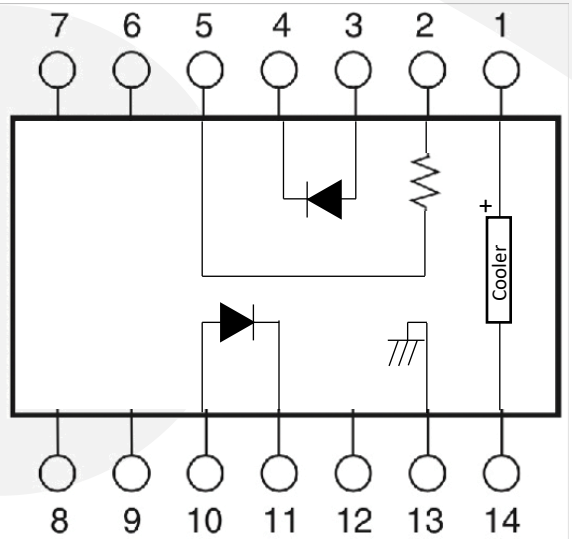



LD-1550P-BP

SPECIFICATIONS

Center Wavelength	1530 nm – 1560 nm
Optical Output Power (CW)	20 mW typ.
Operating Current (CW)	200 mA typ.
Peak Output Power (Pulse)	50 mW typ.
Operating Current (Pulse)	500 mA typ.
Forward Voltage	2.5 V typ.
Series Resistance	25 Ω typ.
Threshold Current	25 mA typ.
Monitor Current	0.10 mA min., 1.0 mA max.
Photodiode Dark Current	2 nA typ., 100 nA max.
Side Mode Suppression	30 dB typ.
Spectral Width	10 nm max.
Optical Isolation	30 dB typ. (No isolator version is available up on special request)
Polarization Extinction Ratio	20 dB typ.

GENERAL

MECHANICAL

Operating Temperature	-10°C to +60°C
Storage Temperature	-40°C to +70°C
Operating Humidity	95% @ < 30°C
Optical Fiber Type	SMF28 (PANDA PM available)
Optical Connector	FC/APC, other available

TEC AND THERMISTOR CHARACTERISTICS

TEC Current	1.0 A max.
TEC Voltage	2.4 V max.
TEC Resistance	2.4 Ω typ.
Thermistor Resistance	7.7 k Ω min., 12.6 k Ω max.
Thermistor B Constant	3,270 K min., 3,450 K typ., 3,630 K max.

ABSOLUTE MAXIMUM RATING

Reverse Voltage	2 V
Operating Current	200 mA
PD Reverse Voltage	20 V
PD Forward Current	10 mA
TEC Voltage	4 V
TEC Current	4 A



TYPICAL LASER DIODE LI CURVE @ 25°C

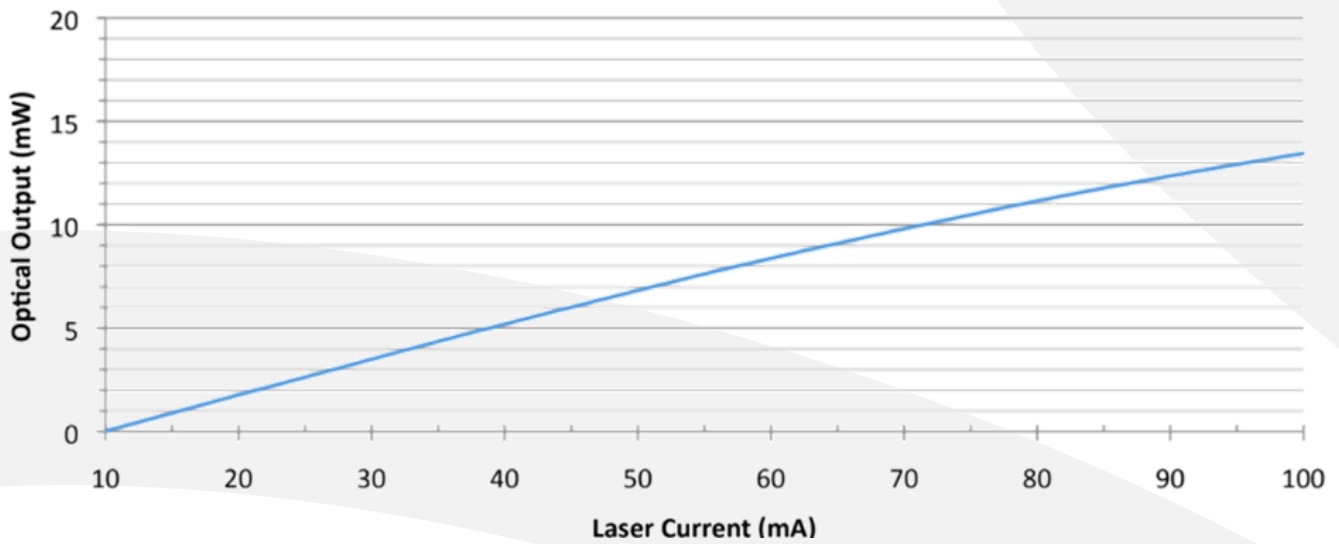

TYPICAL OPTICAL SPECTRUM @ 25°C @ 10 mW

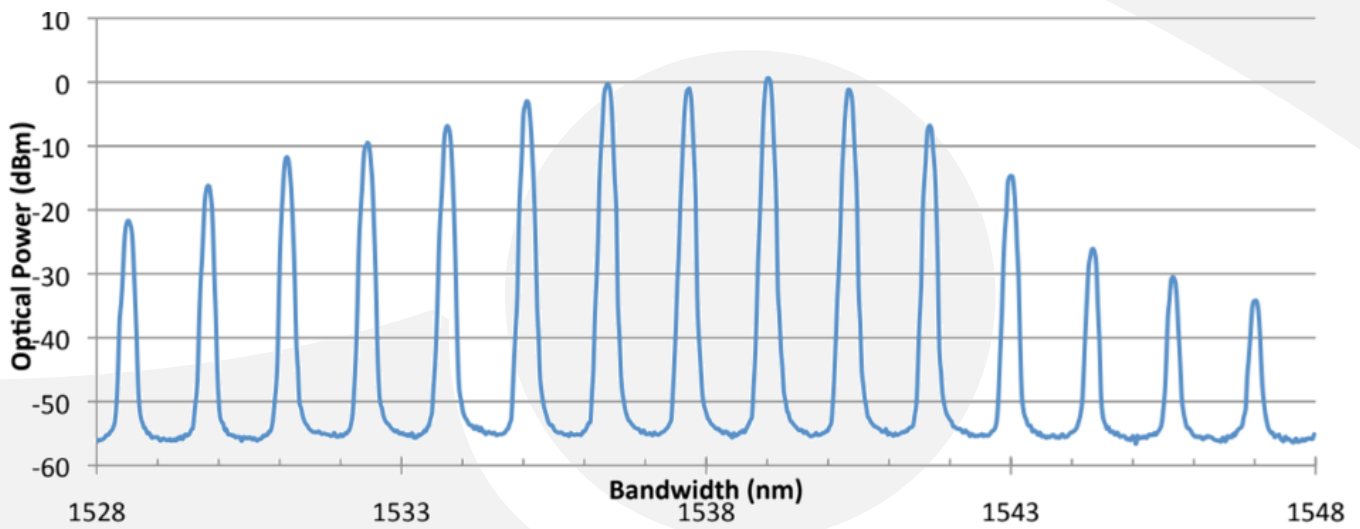

LD-1550P-BP

MECHANICAL DRAWING

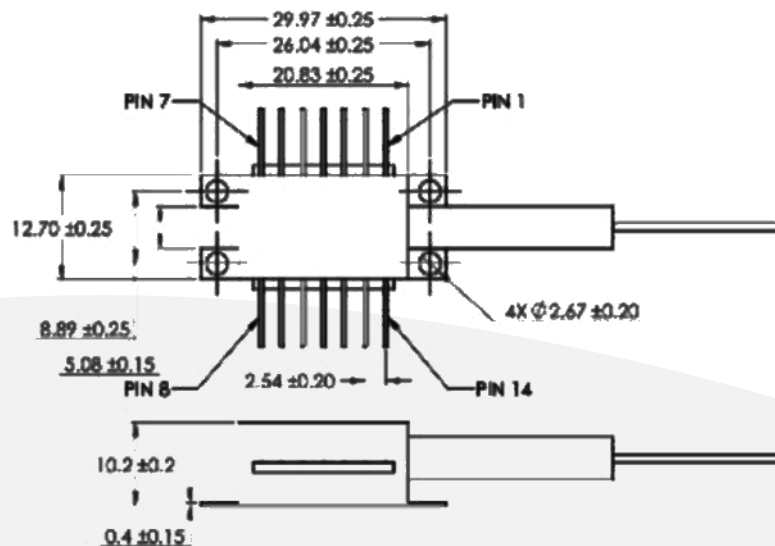

Unit: mm

AVAILABLE MODULE

- NPL-P

Phoenix Series, Portable



The Optilab NPL-P series is a Nanosecond Pulsed Laser Portable Photonics Instrument (PPI) series in handheld form factor with touchscreen control and intuitive GUI.

ORDERING OPTIONS

LD-15xxP-BP-yy-zz

xxxx: Wavelength in nm

yy: PM for PM, None for SM

zz: Output Power in mW: 20, 30

