



# LCA-65



DEVICE

## 65 GHz Lightwave Component Analyzer

OVERVIEW

The Optilab LCA-65 is a high performance lightwave component analyzer with an operational bandwidth beyond 65 GHz. It offers an ideal choice to characterize electro-optical components and provides excellent compatibility with the Keysight/Agilent network analyzers. The LCA-65 is an ideal measurement solution for analog photonic applications beyond 60 GHz. The instrument is traceable to international standards and provides guaranteed specifications for electro-optical responsively S-parameter measurements in a turn-key solution. Contact Optilab for more information.

FEATURES

- Over 65 GHz Operational Bandwidth
- Built-in Tunable Laser w/ Power Adjustment
- Integrated Narrow Linewidth Laser
- Full VNA Compatibility
- Touchscreen LCD & USB Interface
- Optional Power Monitoring

USE IN

- High-Speed Component Characterization
- EO / OE Measurement
- Fiber Channel & CATV Transmission System
- RF Over Fiber
- Research and Development
- Lab Instrument

FUNCTIONAL DIAGRAM

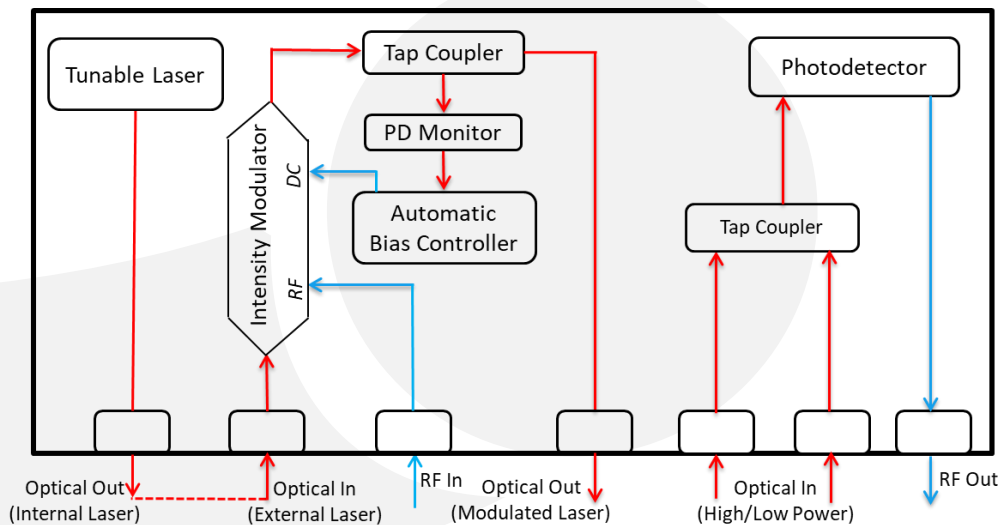



# LCA-65

## SPECIFICATIONS

Internal Laser Wavelength	1550 nm (customizable)
Internal Laser Output Power	Up to 50 mW (adjustable)
Internal Laser Linewidth	≤ 1 MHz (customizable)
Internal Laser SMSR	≥ 40 dB
Internal Laser RIN	≤ -150 dB/Hz
Modulator Bandwidth	≥ 60 GHz
Modulator Return Loss	≤ -10 dB
Modulator Input Impedance	50 Ω typical
Modulator RF V <sub>π</sub>	3.0 V typical @ 10 GHz 6.5 V typical @ 60 GHz
Modulated Output Power	≥ 5 mW
PD Operating Wavelength	1200 nm to 1650 nm
PD Bandwidth	≥ 60 GHz
PD Responsivity	0.5 A/W typical
PD S22 Characteristics	≤ -10 dB
PD Dark Current @ 25°C, -5V	10 nA typ. 100 nA max.

## GENERAL

Operating Temperature	+5°C to +35°C
Storage Temperature	-40 °C to +70 °C
Operating Humidity	15% to 80% Relative Humidity
Power Supply	100 to 240 VAC
Optical Input Fiber	Panda PM 1550
Optical Output Fiber	SMF-28
Optical Connectors	Cleanable FC APC (customizable)
RF Port Connectors	NMD ruggedized 1.85 mm female (customizable)
Control Interface	Touchscreen LCD & USB 2.0
Assembly Dimension (H x W x D)	5.3" x 17.3" x 23.8"
Recommended Calibration Period	1 year

## MECHANICAL





# LCA-65



TYPICAL MODULATOR S21 RESPONSE

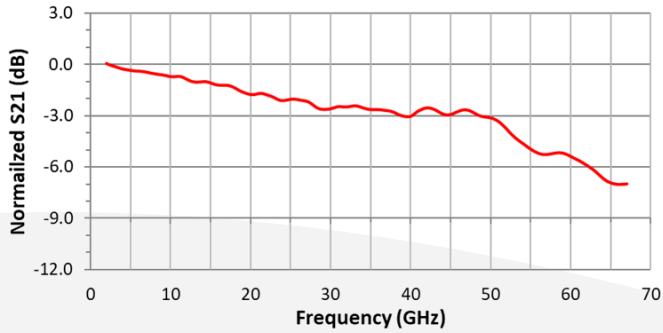

TYPICAL MODULATOR S11 RESPONSE

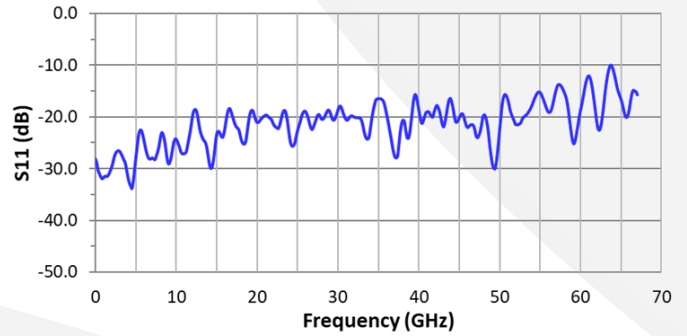

TYPICAL PD S21 RESPONSE

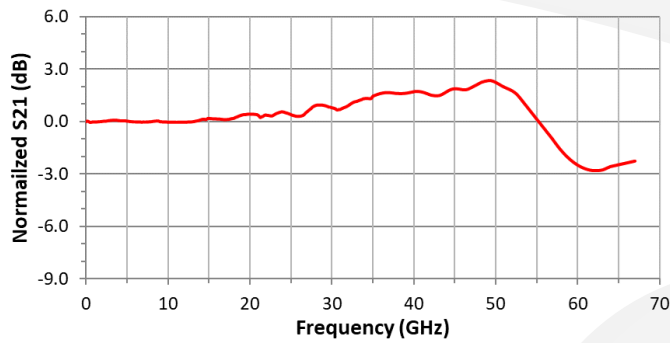

TYPICAL PD S22 RESPONSE

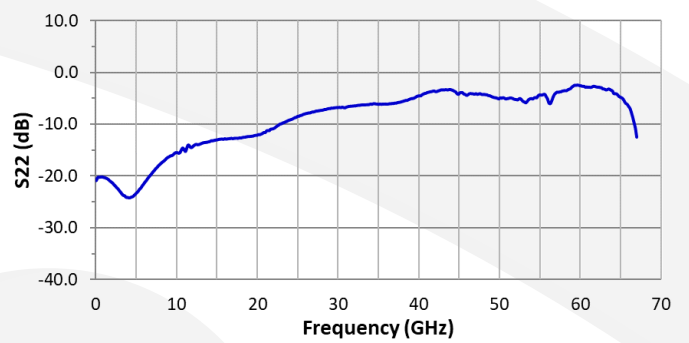

TYPICAL LINK GAIN

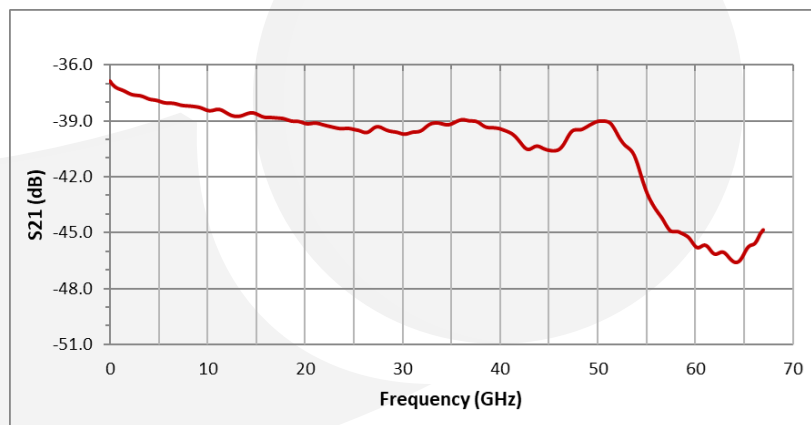



# LCA-65

1	Internal Laser Output
2	Modulator Input Port
3	Modulator Output Port
4	RF Input Port
5	Power Button
6	Laser Enable Button
7	Optical Input Power, Low Power
8	Optical Input Power, High Power
9	RF Output Port
10	AC Power Socket
11	Main AC Power Switch
12	USB Female Socket
13	Ventilation Fans



## MECHANICAL DRAWING

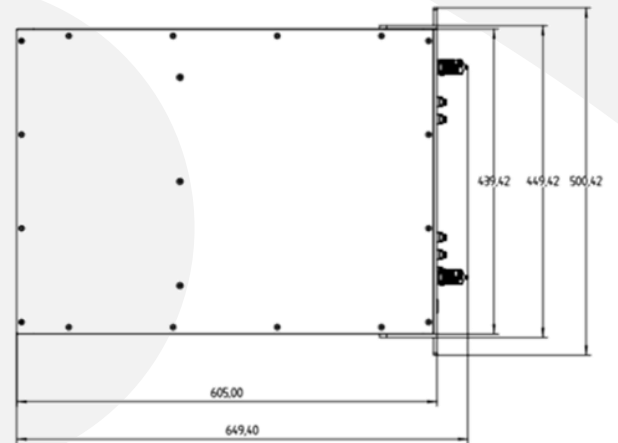
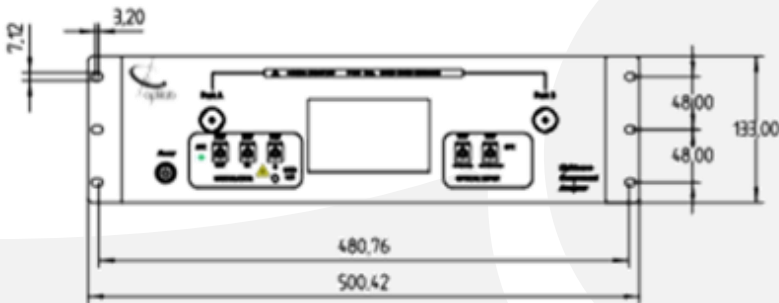

Unit: mm

