

EDFA-L-XX-PM-R



Dual Stage Erbium-Doped Fiber Amplifier, C-Band, Rackmount w/PM Output

OVERVIEW

The Optilab EDFA-L-XX-PM-R Erbium-Doped Fiber Amplifier (EDFA) is a dual pump, versatile amplifier designed for optical communication and other general-purpose optical applications. By using a dual pump laser (980nm & 1480nm) amplifier design with high efficiency, EDFA-L-XX-PM-R provides optical gain up to 35 dB, while maintaining low noise figure (NF) of 5 dB. The EDFA-L-XX-PM-R amplifier produces optical output levels up to +22 dBm with an input power level range from -12 dBm to +7 dBm. Featuring adjustable Polarization Maintaining (PM) output level power via ACC through the front panel and software control through USB in a standard 1U rackmount. Contact Optilab for more information.

FEATURES

- PM Output
- Up to +22 dBm output power
- Dual Pump Design
- Optical gain up to 35 dB
- Input power range: -12 dBm to +7 dBm
- Automatic Current Control (ACC)
- Software control through USB

USE IN

- Optical Communication
- Test and measurement
- Pulse Amplification
- General-purpose optical amplifier

FUNCTIONAL DIAGRAM

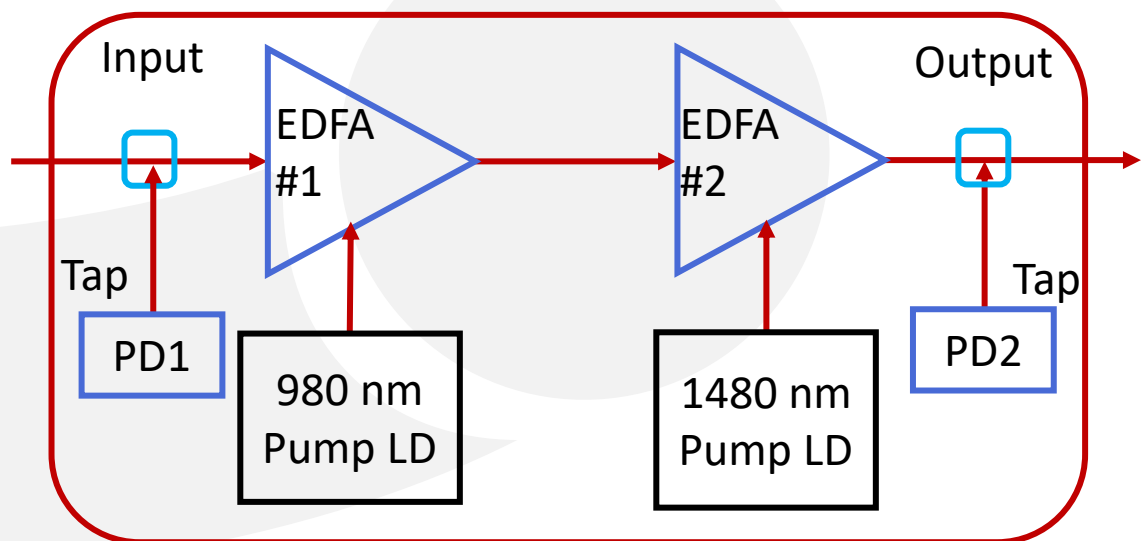

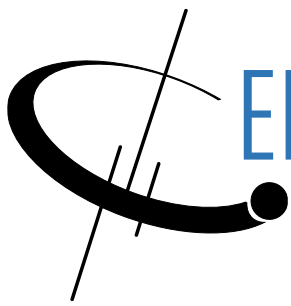

EDFA-L-XX-PM-R

SPECIFICATIONS

OPTICAL

Operating Range	1568 nm – 1605 nm
Output Power Levels	Up to +22 dBm
Input Power Range	-12 dBm to +7 dBm
Optical Gain	Up to 35 dB @ -10 dBm input
Noise Figure (NF)	< 5.0 dB typ. @ -10 dBm input
Optical Return Loss	50 dB min.
Input/Output Optical Isolation	30 dB min.
Polarization Mode Dispersion	1.0 ps max.
Polarization Dependent Gain	0.10 dB max.
Output Power Stability	0.10 dB over 8 hours
Input/Output Fiber Type	PANDA PM

MECHANICAL

Operating Temperature	-10°C to +60°C
Storage Temperature	-40°C to +70°C
Power Supply Requirements	80 – 240 V, 43 – 63 Hz AC
Power Consumption	60 W max.
Output Level Control	Pump Lasers Current Adjustment
Monitoring	Pump Laser Temperature
Computer Interface	LabVIEW via USB
Display	Input/Output Power Level, TEC Temperature
Alarms	Temperature and Input Power
Optical Connectors	FC/APC., Other Option Available
Housing Dimensions	1RU 482.60 (L) x 470.57 (W) x 44.00 (H) (mm)

ORDERING OPTIONS

EDFA-L-XX-PM-R

XX Output Power Level: 22 dBm



EDFA-L-XX-PM-R

MECHANICAL DRAWING

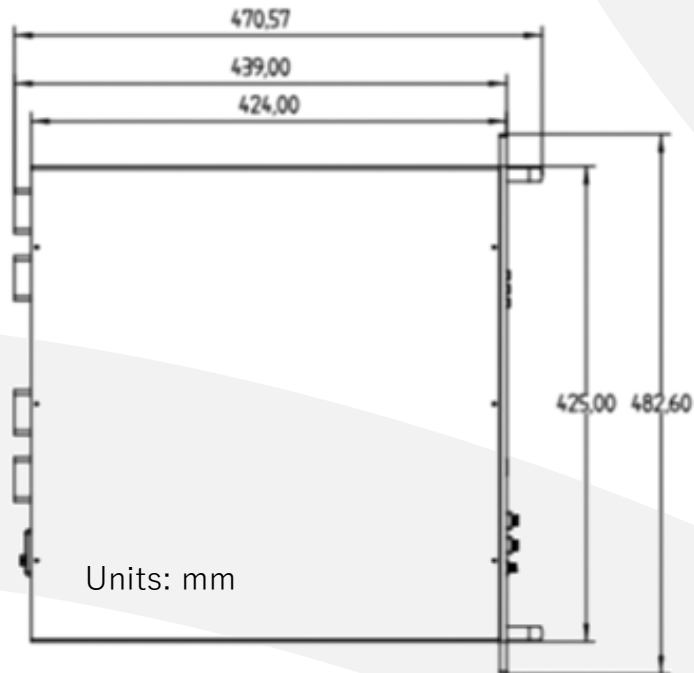

RELATED BENCHTOP

- **EDFA-L-XX-PM-B**



The Optilab EDFA-L-XX-PM-B is a Polarization Maintaining (PM) high-gain EDFA in a benchtop, featuring front panel touch screen control.

