

VW 1.9L 2.0L TDI ADAPTER KIT Installation Guide for TD Conversion kits



This document is a general guide for how to install the TD Conversion's TDI adapter kit to the 1.9L 2.0L TDI engine. The instructions found in this guide can be applied to all TDI adapter kits sold by TD Conversions. Please follow this guide from start to finish and do not skip steps. Failure to follow recommended instructions may result in damage to your adapter kit, engine, or transmission. If you have any concerns with these installation steps, please contact us at [**info@tdconversions.com.**](mailto:info@tdconversions.com)

Contents

Introduction	5
Application	5
Requirements	5
Parts.....	6
Tools	7
Assembly Photos.....	8
Overview of Install Guide	9
Crank Adapter Install	10
Solid Profile Crank Adapter Install	11
Two-Piece Crank Adapter Install.....	12
(DISCONTINUED) H – style Crank Adapter Install	13
Engine Plate Install.....	15
Modify Bellhousing for Starter Motor	17
Transmission Plate Install.....	19
Flexplate/Flywheel Install	20
Starter Motor Install	21
Install Dowels into Transmission Adapter Plate.....	23
Mate Transmission to Adapter Kit Overview	24
Kit Specific Modifications and Hardware.....	26
Chevy SBC & LS V8 Adapter Kits.....	26
<i>Transmission Bellhousing Hardware.....</i>	<i>26</i>
<i>Bellhousing Modification</i>	<i>26</i>
<i>Starter Motor Positions (Powermaster).....</i>	<i>27</i>
<i>Starter Motor Notes (Toyota 4.7 starter).....</i>	<i>28</i>
<i>Kit Specific Notes.....</i>	<i>29</i>
Chevy 2.2L and 2.8L V6 Adapter Kits	30
<i>Transmission Bellhousing Hardware.....</i>	<i>30</i>
<i>Bellhousing Modification</i>	<i>30</i>
<i>Starter Motor Notes (Toyota 4.7 starter).....</i>	<i>31</i>
<i>Kit Specific Notes.....</i>	<i>32</i>
Ford 3.0L V6 Adapter Kits	33

Installation Manual Special Note:

The products supplied in this kit are manufactured and assembled specifically for this conversion type. The hardware supplied may have more or less bolts than required for your specific application. Modification to components will void any possible warranty or returns. This information is provided as a guide to aid with installation process, it is by no means “complete and exact”. We recommend using your vehicle specific Factory Service Manual for additional information.

<i>Transmission Bellhousing Hardware</i>	33
<i>Bellhousing Modification</i>	33
<i>Starter Motor Notes (Toyota 4.7 starter)</i>	34
<i>Kit Specific Notes</i>	34
Ford 4.0L V6 Adapter Kits	35
<i>Transmission Bellhousing Hardware</i>	35
<i>Bellhousing Modification</i>	35
<i>Starter Motor Notes (Toyota 4.7 starter)</i>	36
<i>Kit Specific Notes</i>	36
Ford Small Block V8 Adapter Kits.....	37
<i>Transmission Bellhousing Hardware</i>	37
<i>Bellhousing Modification</i>	37
<i>Starter Motor Notes (Toyota 4.7 starter)</i>	38
<i>Kit Specific Notes</i>	39
JEEP 4.0L, 4.2L, and AMC V8 Adapter Kits	40
<i>Transmission Bellhousing Hardware</i>	40
<i>Bellhousing Modification</i>	40
<i>Starter Motor Notes (Toyota 4.7 starter)</i>	41
JEEP 3.8L Adapter Kits.....	42
<i>Transmission Bellhousing Hardware</i>	42
<i>Bellhousing Modification</i>	42
<i>Starter Motor Notes (Toyota 4.7 starter)</i>	43
JEEP 3.6L Adapter Kits.....	44
<i>Transmission Bellhousing Hardware</i>	44
<i>Bellhousing Modification</i>	44
<i>Starter Motor Notes (Toyota 4.7 starter)</i>	45
Jeep 2.5L Adapter Kits.....	46
<i>Transmission Bellhousing Hardware</i>	46
<i>Bellhousing Modification</i>	46
<i>Starter Motor Notes (Toyota 4.7 starter)</i>	47
Nissan 2.4L Adapter Kits	48
<i>Transmission Bellhousing Hardware</i>	48

Installation Manual Special Note:

The products supplied in this kit are manufactured and assembled specifically for this conversion type. The hardware supplied may have more or less bolts than required for your specific application. Modification to components will void any possible warranty or returns. This information is provided as a guide to aid with installation process, it is by no means “complete and exact”. We recommend using your vehicle specific Factory Service Manual for additional information.

<i>Bellhousing Modification</i>	48
<i>Starter Motor Notes (Toyota 4.7 starter)</i>	49
Nissan 3.0L/3.3L Adapter Kits	50
<i>Transmission Bellhousing Hardware</i>	50
<i>Bellhousing Modification</i>	50
<i>Starter Motor Notes (Toyota 4.7 starter)</i>	51
Toyota 4.0L Adapter Kits	52
<i>Transmission Bellhousing Hardware</i>	52
<i>Bellhousing Modification</i>	52
<i>Starter Motor Notes (Toyota 4.7 starter)</i>	53
Toyota 3.0/3.4L Adapter Kits	54
<i>Transmission Bellhousing Hardware</i>	54
<i>Bellhousing Modification</i>	54
<i>Starter Motor Notes (Toyota 4.7 starter)</i>	55
Toyota 2.7L Adapter Kits	56
<i>Transmission Bellhousing Hardware</i>	56
<i>Bellhousing Modification</i>	56
<i>Starter Motor Notes (Toyota 4.7 starter)</i>	57
Toyota 22R Adapter Kits	58
<i>Transmission Bellhousing Hardware</i>	58
<i>Bellhousing Modification</i>	58
<i>Starter Motor Notes (Toyota 4.7 starter)</i>	59

Installation Manual Special Note:

The products supplied in this kit are manufactured and assembled specifically for this conversion type. The hardware supplied may have more or less bolts than required for your specific application. Modification to components will void any possible warranty or returns. This information is provided as a guide to aid with installation process, it is by no means “complete and exact”. We recommend using your vehicle specific Factory Service Manual for additional information.

Introduction

The instructions contained in this document are a guide to assist experienced automotive mechanics with installing the TD Conversion TDI Adapter Kit.

Application

This guide is only applicable for the TDI Adapter Kits sold by TD Conversion. This guide works with nearly all Volkswagen 1.9L 2.0L TDI engines. Make sure you are using the correct adapter kit that is compatible with your transmission. The steps to install the transmission to this adapter kit is the same for most transmission, only bolt length and size will vary by application. Some bolts may not be used with your application. Be aware of the crank adapter installation steps, there are two types of crank adapters (solid and H-style) and it is critical you follow the correct procedure.

Requirements

The TD Conversion's adapter kit is a bolt together process but will require modifications to your bellhousing for starter motor drive gear clearance. For this modification, an angle and/or die grinder will be required.

Not supplied with adapter kit:

- For automatic transmission use your existing factory flexplate and flexplate bolts.
- For manual transmission use your existing factory flywheel and flywheel bolts.

Installation Manual Special Note:

The products supplied in this kit are manufactured and assembled specifically for this conversion type. The hardware supplied may have more or less bolts than required for your specific application. Modification to components will void any possible warranty or returns. This information is provided as a guide to aid with installation process, it is by no means "complete and exact". We recommend using your vehicle specific Factory Service Manual for additional information.

Parts

Inside your adapter kit shipping box you will find a Bill of Materials for the exact items included with your kit.

The chart below is a general overview of the parts included.

Part List Example	
Major Components	Qty
VW TDI 1.9/2.0L Billet Engine Adapter Plate	1
Billet Transmission Adapter Plate	1
VW 1.9/2.0L Crank Adapter (transmission specific)	1
Starter motor	1
Starter Adapter (kit specific)	1
Starter motor shim and/or spacer (kit specific)	1
VW TDI 1.9/2.0L Engine Adapter Hardware Listed Below	
M12 x 1.75 x 35mm 8.8 Plated Hex Bolts	1
M12 x 1.75 x 40mm 8.8 Plated Hex Bolts	3
M12 x 1.75 x 55mm 8.8 Plated Hex Bolts	4
M10 x 1.5 x 35mm 8.8 Plated Hex Bolts	3
M12 Flat Washers	8
M12 Lock Washers	8
M12x 1.75 Flanged Nuts	4
M10 Flat Washers	3
M10 Lock Washers	3
1/2" x 1-1/2" NC Grade 8 Bolts	6
1/2" Nordlock Washers	6
Transmission Adapter Hardware Listed Below	
See "Adapter Kit Specific Notes" section for exact hardware list	Kit specific
Crank Adapter Hardware Kit	
M10 x 1.0 x (30, 40, or 50mm) Socket Head Bolts	6
M10 x 1.0 x 3/8" NF Custom Stud (only for H – style crank adapters)	6
3/8" Nordlock Washer (only for H – style crank adapters)	6
3/8" NF Nut Plated (only for H – style crank adapters)	6
Starter Motor Hardware Kit	
1/4" NC Socket Head Bolts (PowerMaster Starter Motor)	2 -3
5/16" NC Hex bolts (Toyota 4.7 Starter Motor)	2

Installation Manual Special Note:

The products supplied in this kit are manufactured and assembled specifically for this conversion type. The hardware supplied may have more or less bolts than required for your specific application. Modification to components will void any possible warranty or returns. This information is provided as a guide to aid with installation process, it is by no means "complete and exact". We recommend using your vehicle specific Factory Service Manual for additional information.

Tools

- Red Loctite Thread locker
- Blue Loctite Thread locker
- Anti-seize thread lubricant
- torque wrench (3/8 drive)
- 19mm Socket
- 19mm Wrench
- 17mm Socket
- 17mm Wrench
- 3/4" Socket
- 9/16" Socket
- 9/16" Wrench
- 5/8" Socket
- 5/8" Wrench
- 1/4" Allen Key
- 3/16" Allen Key
- 8mm Allen Key
- 9/16" crows foot (3/8 drive)
- Angle grinder
- Die Grinder
- Rubber Mallet
- socket for VW accessory pulley
- breaker bar
- feeler gauges
- metal file
- (H- style crank adapter only) 14mm stubby SNAP-ON combination wrench (Part #: OXIM14B)
- (H- style crank adapter only) 14mm triple square 3/8 drive socket (Part #: BLPXZNM3814)

Installation Manual Special Note:

The products supplied in this kit are manufactured and assembled specifically for this conversion type. The hardware supplied may have more or less bolts than required for your specific application. Modification to components will void any possible warranty or returns. This information is provided as a guide to aid with installation process, it is by no means "complete and exact". We recommend using your vehicle specific Factory Service Manual for additional information.

Assembly Photos

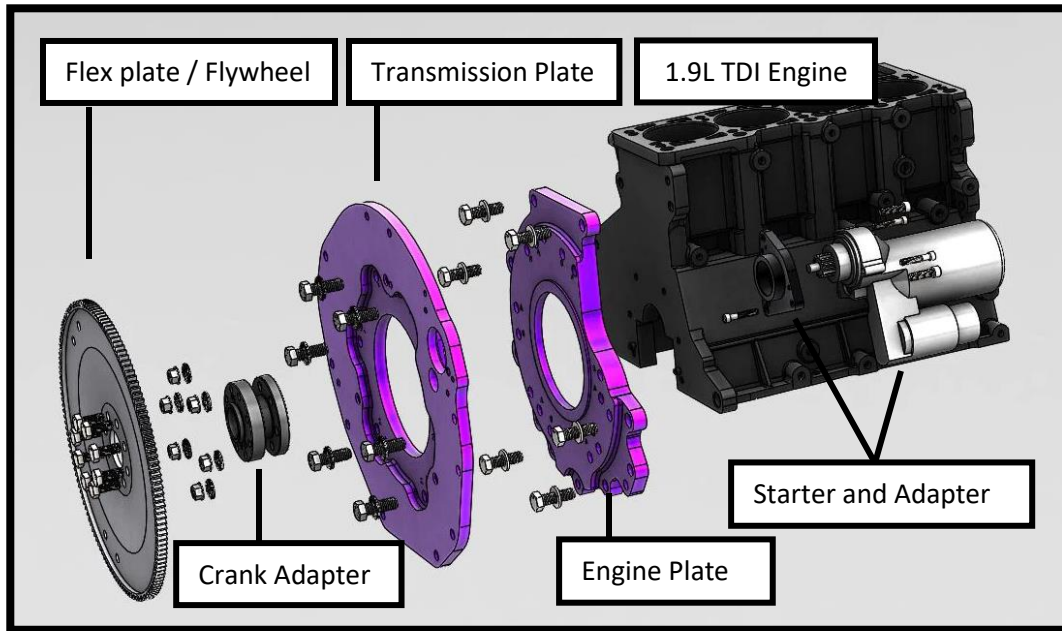
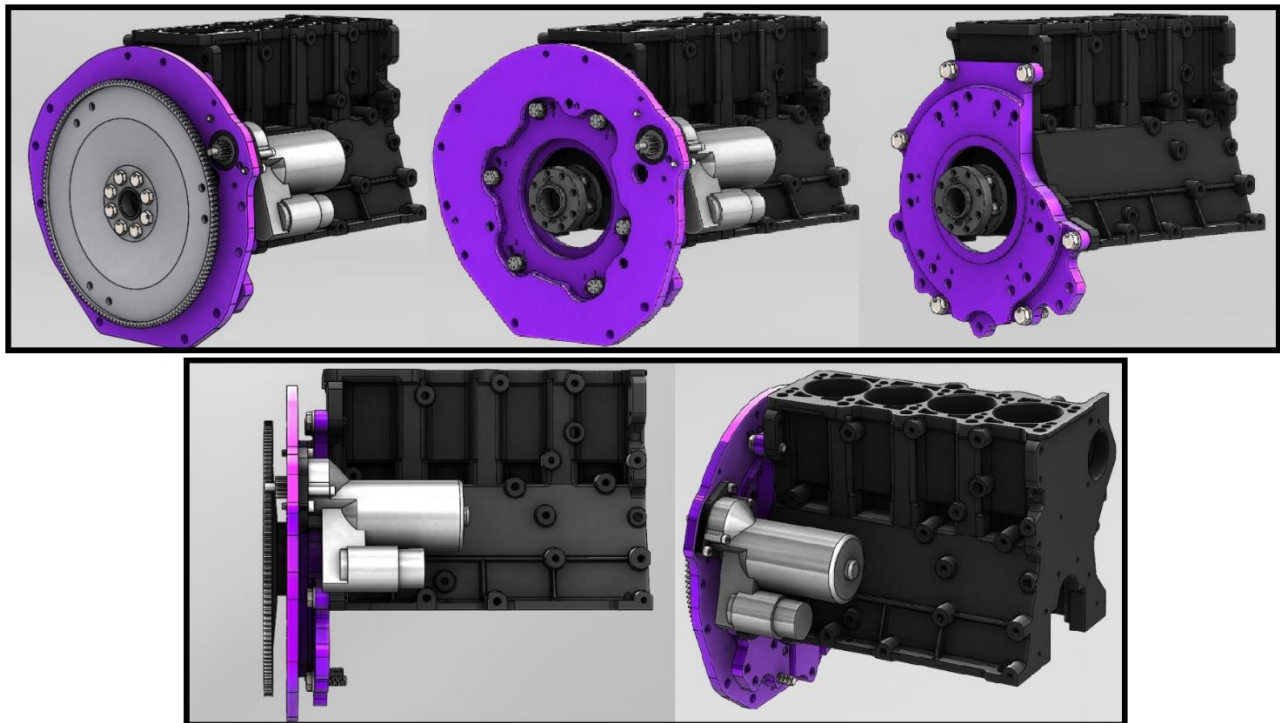

Figure 1: 3D exploded model of the complete assembly



Installation Manual Special Note:

The products supplied in this kit are manufactured and assembled specifically for this conversion type. The hardware supplied may have more or less bolts than required for your specific application. Modification to components will void any possible warranty or returns. This information is provided as a guide to aid with installation process, it is by no means “complete and exact”. We recommend using your vehicle specific Factory Service Manual for additional information.

Overview of Install Guide

This install guide is designed to be read and worked through from start to finish. Please follow the steps in order as presented. If you have any concerns, feel free to contact us.

Here are the main install steps that you will perform:

1. Read install guide from start to finish before beginning install.
2. Confirm you have received all parts and hardware
3. Collect required tools
4. Install crank adapter onto engine
5. Install engine adapter plate
6. Test fit transmission adapter plate onto transmission bellhousing
7. Modify bellhousing for starter motor drive gear
8. Install transmission adapter plate onto engine adapter plate
9. Install flex plate or flywheel onto crank adapter
10. Install starter motor onto transmission adapter plate
11. Check starter motor drive gear engagement on ring gear
12. Test start engine
13. Position engine in engine bay
14. Attach transmission to transmission adapter plate

For additional information on your specific adapter kit, reference the last section of this guide, “Kit Specific Details”.

Installation Manual Special Note:

The products supplied in this kit are manufactured and assembled specifically for this conversion type. The hardware supplied may have more or less bolts than required for your specific application. Modification to components will void any possible warranty or returns. This information is provided as a guide to aid with installation process, it is by no means “complete and exact”. We recommend using your vehicle specific Factory Service Manual for additional information.

Crank Adapter Install

All our TDI kits require a crank adapter. There are two reasons a crank adapter is required:

<p>Crank shaft bolt pattern compatibility:</p> <ul style="list-style-type: none"> The crank adapter allows the OEM flywheel from your engine application to bolt to the Volkswagen 1.9/2.0 TDI crank shaft. The OEM flywheel is therefore retained with no additional modifications to the flywheel/flexplate. 	<p>Transmission coupling to engine:</p> <ul style="list-style-type: none"> Due to the nature of coupling a non-VW transmission to a VW engine, we must use adapter plates to combine the two different bellhousing bolt patterns. The thickness of the plates offsets the transmission, which needs to be corrected using a crank adapter.
--	--

There are **3 types** of crank adapters. Please identify which crank adapter you have.

1. Solid crank adapter

The solid crank adapter is used for applications where the crank bolt patterns do not interfere with each other. For example, the Jeep 4.0L crank bolt pattern does not interfere with the VW crank bolt pattern, therefore a solid crank adapter is used.

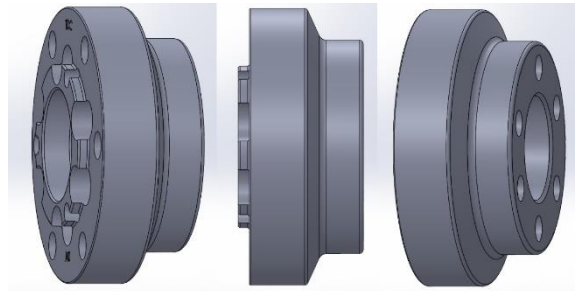

2. Two-piece crank adapter (NEW, 2022)

For applications where the crank bolt patterns overlap and interfere with each other, we use a two-piece crank adapter. This adapter has a slight interference fit and is pressed together as you tighten the outer coupling bolts. This creates near perfect concentricity with the driveline zero line. This crank adapter was introduced late 2022 and replaces the H-style crank adapter. The two-piece crank adapter is superior to the H-style crank adapter in three ways. 1: simple straightforward install procedure. 2: no custom hardware. 3: increased allowable engine torque output. This two-piece design is a trickle-down design from our 3.0 TDI adapter kits which has a significantly larger torque output.



3. H-style crank adapter (Legacy)

The H-style crank adapter is our original solution for applications with interfering bolt patterns. This style is being phased out due its tedious install procedure and the need for custom imperial to metric studs. Select applications now use the two-piece crank adapter.

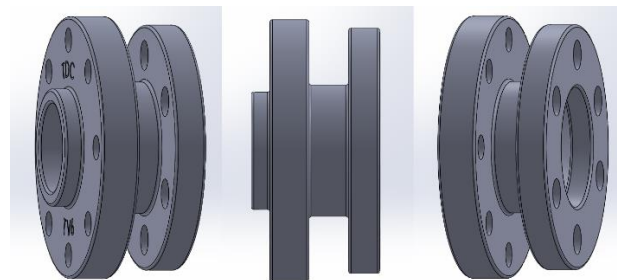

Installation Manual Special Note:

The products supplied in this kit are manufactured and assembled specifically for this conversion type. The hardware supplied may have more or less bolts than required for your specific application. Modification to components will void any possible warranty or returns. This information is provided as a guide to aid with installation process, it is by no means "complete and exact". We recommend using your vehicle specific Factory Service Manual for additional information.

Solid Profile Crank Adapter Install

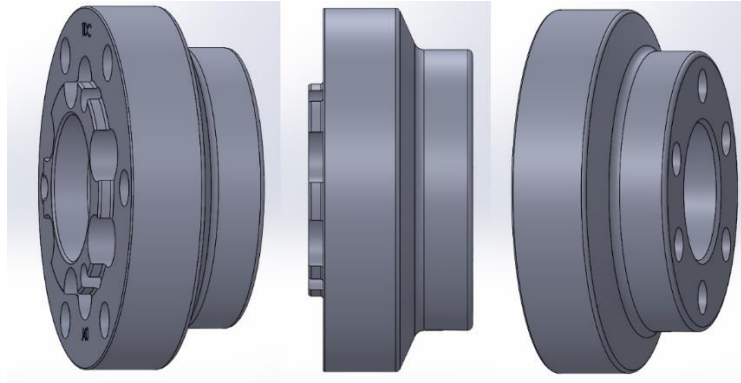

Parts needed: Crank adapter hardware kit, crank adapter (pilot bushing preinstalled in manual kits).

Tools required: 6mm Allen key or socket, ratchet, Red Loctite, socket for VW accessory pulley, breaker bar, feeler gauges, metal file.

- 1) Ensure the surface of your engine's crank is **clean and free of debris**. Use a metal file to clean any burrs or raised metal grooves that may otherwise not let crank adapter sit flat.
- 2) Locate the six M10 x 1.0 socket head bolts for securing adapter to VW crank shaft. They will be nitride black with a length of 30mm, 40mm, or 50mm.
- 3) Fit the crank adapter onto your engine crank, as seen in figure 3. The Volkswagen bolt pattern is asymmetrical, so there is only one way it will fit.
- 4) **Apply Red or Blue Loctite to the M10 socket head bolts and incrementally torque the bolts in a star pattern in three steps; 1. tighten all bolts to 20ft-lb, 2. then all to 40 ft-lb, 3. and finally all to 60 ft-lb.** You will need to counter hold the crank by using a socket and breaker bar on the VW accessory pulley bolt.

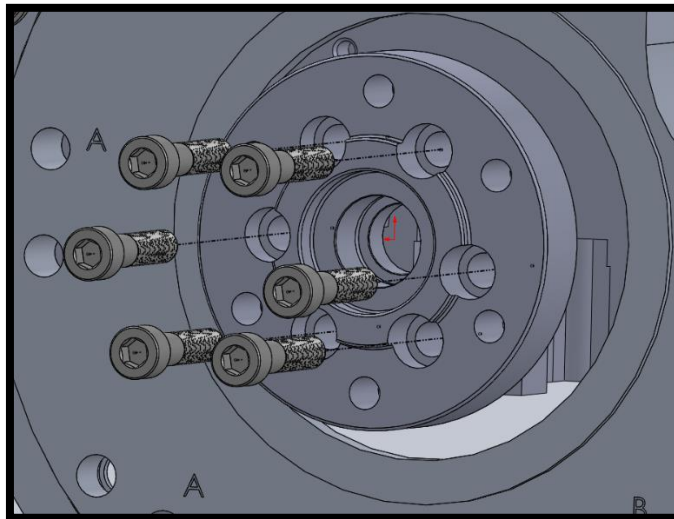

Figure 3: Example image of a Chevy Small Block crank adapter

- 5) **Let the red Loctite cure for 24 hours before starting the engine.**

Installation Manual Special Note:

The products supplied in this kit are manufactured and assembled specifically for this conversion type. The hardware supplied may have more or less bolts than required for your specific application. Modification to components will void any possible warranty or returns. This information is provided as a guide to aid with installation process, it is by no means "complete and exact". We recommend using your vehicle specific Factory Service Manual for additional information.

Two-Piece Crank Adapter Install



Parts Needed: Crank adapter hardware kit, crank adapter top and base, pilot bushing may be preinstalled.

Tools Required: 6mm hex bit socket, 5/16 hex bit socket, ratchet, torque wrench, Red and Blue Loctite, socket for VW accessory pulley, breaker bar, feeler gauges, metal file, rubber mallet.

- 1) Ensure the surface of your engine's crank is **clean and free of debris**. Use a metal file to clean any burrs or raised metal grooves that may otherwise not let crank adapter sit flat.
- 2) Locate the six M10 x 1.0 socket head bolts for securing base to VW crank shaft. They will be nitride black with a length of 30mm, 40mm, or 50mm depending on the thickness of your kits crank adapter.
- 3) Fit the crank adapter base onto your Volkswagen engine crank. The fit should be snug with little to no movement. If you are unable to get the base onto the crank, place base into boiling water for a few minutes then try again. Wear gloves when hot! A Rubber mallet may be required.
- 4) **Apply Red or Blue Loctite to the M10 socket head bolts and incrementally torque the bolts in a star pattern in three steps; 1. tighten all bolts to 20 ft-lb, 2. then all to 40 ft-lb, 3. and finally all to 60 ft-lb.** The Volkswagen bolt pattern is asymmetrical and will only fit one way. You will need to counter hold the crank by using a socket and breaker bar on the VW accessory pulley bolt.
- 5) **Apply Blue Loctite to the 3/8" socket head bolts. Let cure for 24 hours before starting engine.**
- 6) Align the top adapter onto the base; this is an interference fit and will be pressed on in next steps.
- 7) Begin installing the 3/8" bolts by hand. Snug them all up by hand until there is an even gap all the way around top and bottom crank adapter.
- 8) In a star pattern, incrementally tighten the 3/8" bolts; the top should begin pressing onto the base.
- 9) Once the top is fully seated onto base, torque bolts in a star pattern to 37 ft-lb.
- 10) The crank adapter should now be fully installed. Double check with feeler gauges to make sure there are no gaps between the four mated surfaces.



Installation Manual Special Note:

The products supplied in this kit are manufactured and assembled specifically for this conversion type. The hardware supplied may have more or less bolts than required for your specific application. Modification to components will void any possible warranty or returns. This information is provided as a guide to aid with installation process, it is by no means "complete and exact". We recommend using your vehicle specific Factory Service Manual for additional information.

(Legacy) H – style Crank Adapter Install

Parts needed: Crank adapter hardware kit, crank adapter (pilot bushing preinstalled in manual kits).

Tools needed: 9/16" crowfoot, torque wrench, Red Loctite, anti-seize thread lubricant, socket for VW accessory pulley, breaker bar, feeler gauges, metal file

- 1) Ensure the engine's crank surface is **clean and free of debris**. No burs or raised metal grooves as this will compromise the fitment of crank adapter to crank face. Use a metal file if necessary.
- 2) Locate the 6 crank adapter studs. If your hardware pack does not have studs, then you most likely have the solid crank hub and not the H – style.
- 3) Inspect one stud and notice how there are two different thread types on each stud. The larger diameter end of stud has M10 x 1.0 threads, and the smaller diameter end has 3/8" fine threads. The M10 side threads into the VW engine crank.
- 4) **Apply RED Loctite** to the M10 threads of the studs and hand screw them into the engine crank. Follow the manufacturers instructions on the Loctite Bottle. You can temporarily install the 3/8" NF nut onto the smaller end of stud to help you screw stud into crank. Keep turning by hand until the smooth section of stud is flush with the crank face and no threads visible. Do not continue to thread stud in further, it is not required to do so. You do not need to torque the stud, the RED Loctite will lock stud in place. You can use a wrench to assist turning if you find turning by hand is too hard. **DO NOT CROSS THREAD THE HOLE. IF THERE IS EXCESSIVE FORCE REQUIRED, PLEASE RE-ASSESS WHAT END OF STUD YOU ARE USING. Test fit the crank adapter onto the studs** to make sure all studs are seated far enough into crank. Make sure crank adapter sits flush against the crank face. If the studs are not installed deep enough the stud ends will prevent crank adapter from seating against the crank face. **Use a feeling gauge to check there is no gap between crank adapter and crank face.**
- 5) **MAKE SURE THE TOP OF STUDS DO NOT TOUCH THE UNDERSIDE OF CRANK ADAPTER FLANGE.** There should be clearance between top of studs and underside of crank adapter flange. **Studs must be fully seated into VW crank.**
- 6) Place a 3/8" nordlock washer on each stud and fasten a 3/8" nut onto each stud – as shown in figure. Best technique is to get all 6 nuts started on the threads and progressively turn each nut in a clockwise pattern until the crank adapter is seated against the crank hub. **Do not torque to spec until step 8.**

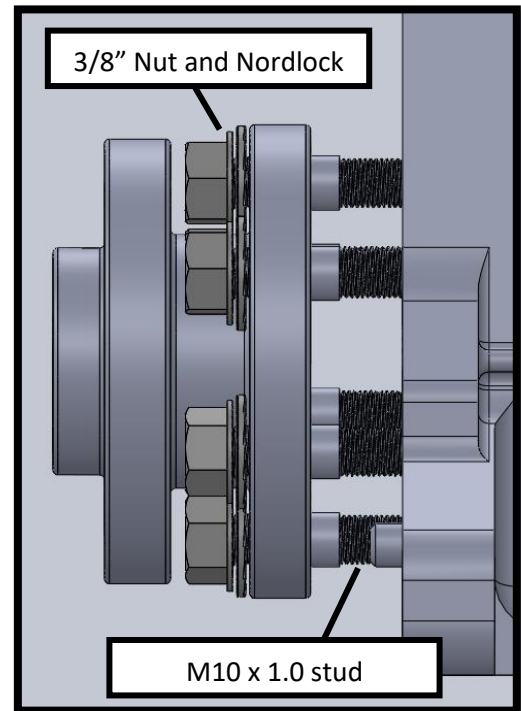

Continue install steps on next page...

Installation Manual Special Note:

The products supplied in this kit are manufactured and assembled specifically for this conversion type. The hardware supplied may have more or less bolts than required for your specific application. Modification to components will void any possible warranty or returns. This information is provided as a guide to aid with installation process, it is by no means "complete and exact". We recommend using your vehicle specific Factory Service Manual for additional information.

*******CRITICAL STEPS TO FOLLOW*******
 *******PLEASE READ THE FOLLOWING CAREFULLY*******

Tools required for tightening the nuts:

- **14mm stubby SNAP-ON combination wrench (Part #: OXIM14B)**
- **14mm triple square 3/8 drive socket (Part #: BLPXZNM3814)**
- **3/8" drive torque wrench**

- 7) Getting a torque wrench onto the nuts is possible by using the stubby wrench and triple square. Insert the triple square into the box end of wrench, then attach torque wrench to triple square socket.



- 8) Use the torque wrench to tighten the nuts in **3 equal steps** (see info below). The wrench **MUST** fit tight on the nut to reduce chance of rounding the nut.

- a) Place the wrench at an angle 90-degrees to the torque wrench handle. This orientation allows you to follow the fastener's torque specification. Calculating a torque multiplier is not necessary because the center of the fastener remains on the same plane as the torque wrench, meaning the overall effective length of the torque wrench stays the same.
- b) Make sure to tighten the nuts down in a star pattern, same pattern as you would tighten wheel lug nuts. You will need to counter hold the crankshaft by placing a socket and breaker bar on the front accessory pulley bolt. This step will require a second person to assist.

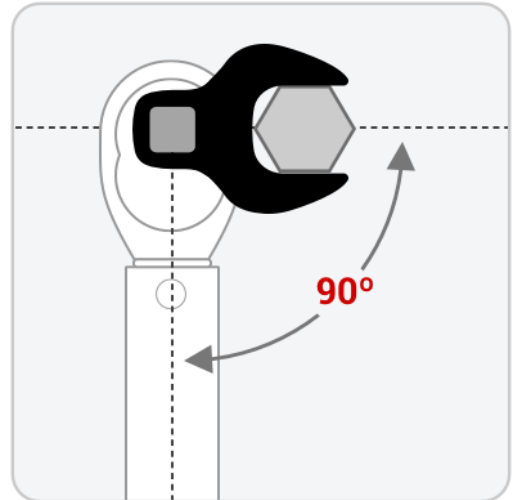

Torque crank adapter nuts using 3 step torque procedure:

- Step 1. Torque to 20 ft-lbs, star pattern**
- Step 2. Torque to 40 ft-lbs, star pattern**
- Step 3. Final Torque to 60 ft-lbs, star pattern**

These custom studs are metric grade 12.9 with imperial grade 8 nuts. The M10 x1.0 grade 12.9 stud section have been tested up to 200 ft-lb of torque without failing. 3/8 Nut and thread section has been tested up to 120 ft-lbs without failing.

- 9) **Let the red Loctite cure for 24 hours before starting the engine.**

Installation Manual Special Note:

The products supplied in this kit are manufactured and assembled specifically for this conversion type. The hardware supplied may have more or less bolts than required for your specific application. Modification to components will void any possible warranty or returns. This information is provided as a guide to aid with installation process, it is by no means "complete and exact". We recommend using your vehicle specific Factory Service Manual for additional information.

Engine Plate Install

Parts Needed: VW Engine Adapter Plate, Engine Hardware Kit.

Make sure the engine block has the two factory installed dowels. Place engine plate onto the back of the engine making sure to fit plate onto the dowels. The plate will require a couple light taps with a rubber mallet to seat the plate onto the dowels. Make sure the plate is flush with engine block. A slight gap is fine as the bolts will pull plate flush to block. Figure 4, shows the bolt locations and type. Figure 5, shows hardware assembly and torque specifications. The Oil pan bolt pattern is different between TDI models, so some bolts and holes may not be used.

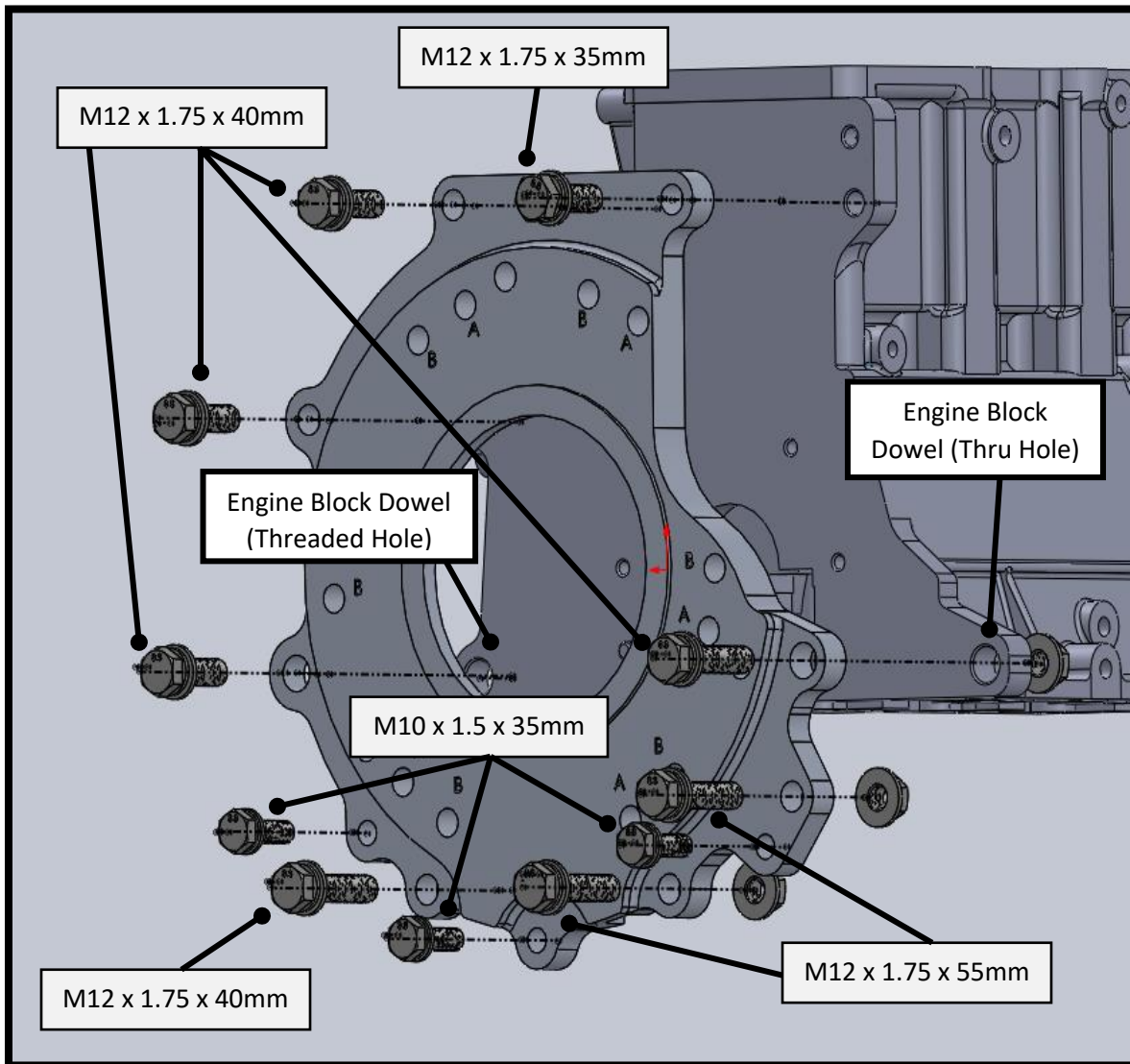

Figure 4: Locations of bolts to fasten the engine plate to the engine.

Installation Manual Special Note:

The products supplied in this kit are manufactured and assembled specifically for this conversion type. The hardware supplied may have more or less bolts than required for your specific application. Modification to components will void any possible warranty or returns. This information is provided as a guide to aid with installation process, it is by no means “complete and exact”. We recommend using your vehicle specific Factory Service Manual for additional information.

Bolt #	Hardware Assembly	Torque Spec.
1 2 3 4	 <p>M12 x 1.75 x 35mm 8.8 Hex Bolt M12 x 1.75 x 40mm 8.8 Hex Bolt</p> <p>M12 Lock Washer Plated</p> <p>M12 Flat Washer Plated</p>	46 ft-lb
5 7 9	 <p>M10 x 1.5 x 35mm 8.8 Plated Cap Screw</p> <p>M10 Lock Washer Plated</p> <p>M10 Flat Washer Plated</p>	26 ft-lb
6 8 10 11	 <p>M12 x 1.75 x 55mm 8.8 Plated Cap Screw</p> <p>M12 Lock Washer Plated</p> <p>M12 Flat Washer Plated</p> <p>M12x 1.75 Flange Nut Plated</p>	65 ft-lb

Figure 5: Bolt number refers to the numbers assigned in figure 4.

Installation Manual Special Note:

The products supplied in this kit are manufactured and assembled specifically for this conversion type. The hardware supplied may have more or less bolts than required for your specific application. Modification to components will void any possible warranty or returns. This information is provided as a guide to aid with installation process, it is by no means “complete and exact”. We recommend using your vehicle specific Factory Service Manual for additional information.

Modify Bellhousing for Starter Motor

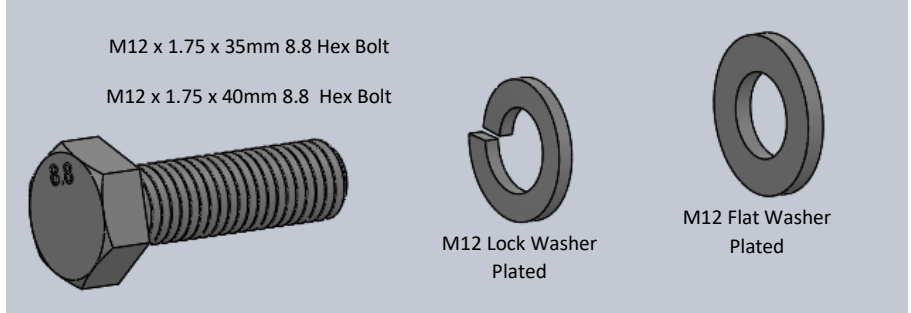
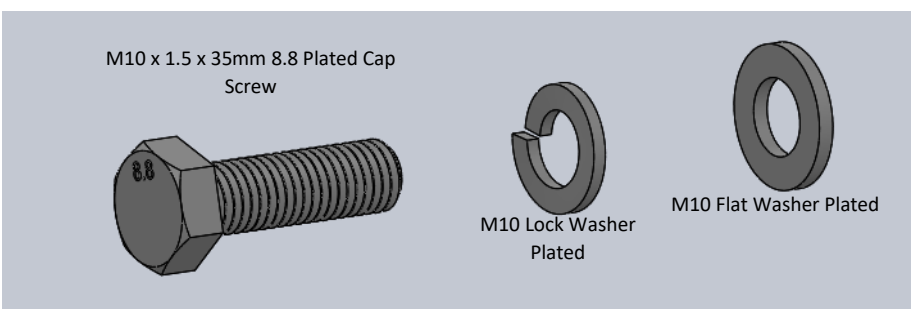
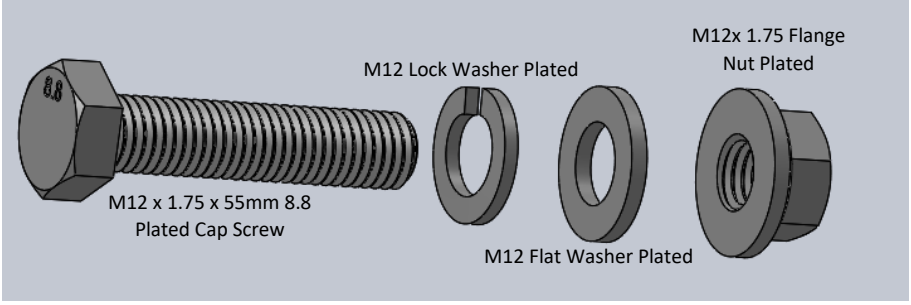
Parts Needed: Transmission Adapter Plate, starter motor, transmission bellhousing, angle grinder, die grinder, marker.

For all TDI adapter kits, the starter motor needs to be relocated to the passenger side (turbo side) of the VW TDI engine. This is the only location that allows for a starter motor to be mounted. Nearly all bellhousings will require modifications by grinding a clearance pocket for the starter motor drive gear to fit.

Starter fitment steps:

- 1) Place your transmission adapter plate onto your stock bellhousing with the “TD Conversions” engraving facing away from the bell. Make sure the transmission dowels in the adapter plate fit into the bellhousing to allow for correct alignment.
- 2) Temporarily secure the bellhousing to adapter using the supplied bolts.
- 3) Look through the starter motor hole in the adapter plate and take note of the material that must be removed for the starter motor drive gear to fit. Use a paint pen to mark surfaces to be removed. The drive gear will typically extend past the end of adapter plate by 1 to 2 inches.



- 4) Remove the adapter plate from the bellhousing and start grinding/cutting away material. An angle grinder and die grinder work well for this task.

Installation Manual Special Note:

The products supplied in this kit are manufactured and assembled specifically for this conversion type. The hardware supplied may have more or less bolts than required for your specific application. Modification to components will void any possible warranty or returns. This information is provided as a guide to aid with installation process, it is by no means “complete and exact”. We recommend using your vehicle specific Factory Service Manual for additional information.

- 5) Once you are satisfied, re-attach the adapter plate to bellhousing and test fit the starter motor with drive gear fully extended. Make sure to attach the provided starter adapter plate if your kit requires one. The pinion drive gear travel is approximately 0.5 inches. A ½" flange nut or piece of metal works well to lock the drive gear in the extended position.

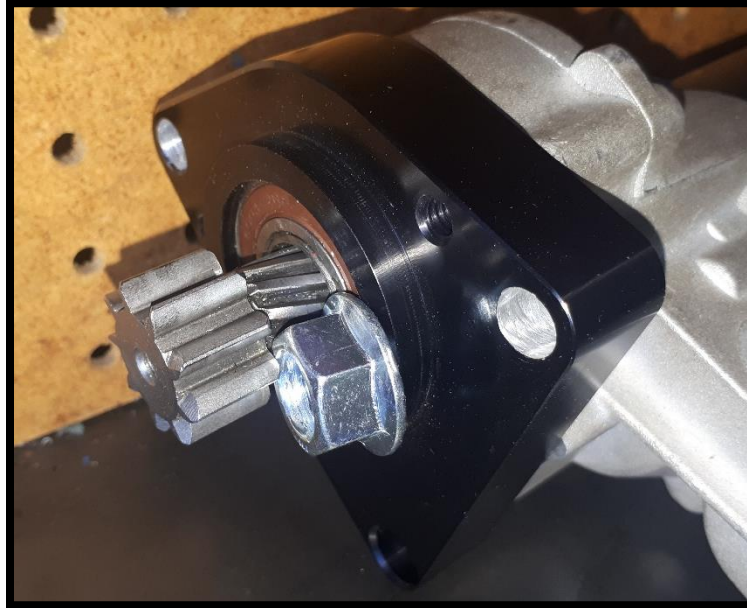

- 6) You may need to repeat steps 1 through 6 several times before you have adequate drive gear clearance. Take your time, some bellhousings require more material removal than others.

Installation Manual Special Note:

The products supplied in this kit are manufactured and assembled specifically for this conversion type. The hardware supplied may have more or less bolts than required for your specific application. Modification to components will void any possible warranty or returns. This information is provided as a guide to aid with installation process, it is by no means "complete and exact". We recommend using your vehicle specific Factory Service Manual for additional information.

Transmission Plate Install

- 1) Remove the transmission adapter plate from the bellhousing if still attached.
- 2) Attach transmission plate to the engine plate. The center hole should fit over the pilot boss on the engine plate. The plates should fit snug with 0.000 to 0.002" of play.
- 3) Take note of the engraved letters on the plates. These markings are used to clock the engine at three different angles. See the engravings guide below. Clocking the engine is necessary in some vehicles for various clearance issues such as: hood clearance, oil pan clearance, front axle clearance, turbo clearance, frame rail clearance.
- 4) Select your desired clocking angle, apply **Blue Loctite** to bolt threads and install **1/2" x 1-1/2" NC Cap Screws** and **1/2" Nord Lock washers**. Torque to **56 ft-lb** in a **STAR PATTERN**, in **3 steps**.
 - Step 1: tighten all bolts to 20 ft-lb, star pattern.
 - Step 2: tighten all bolts to 40 ft-lb, star pattern.
 - Step 3: tighten all bolts to final torque of **56ftlb**, star pattern.

Engine Clocking Engravings Guide:

- 0 degrees, engine vertical position, no lean: line up "A" and "1"
- 10 degrees, engine lean towards passenger side (turbo side): line up "A" and "2"
- 15 degrees, engine lean towards passenger side (VW OEM lean angle): line up "B" and "1"

The engine will safely operate in any of the clocking positions. Extra engine oil may be required. Add the recommended OEM oil volume and then verify dipstick level indicator. Add more oil until dipstick shows correct level.

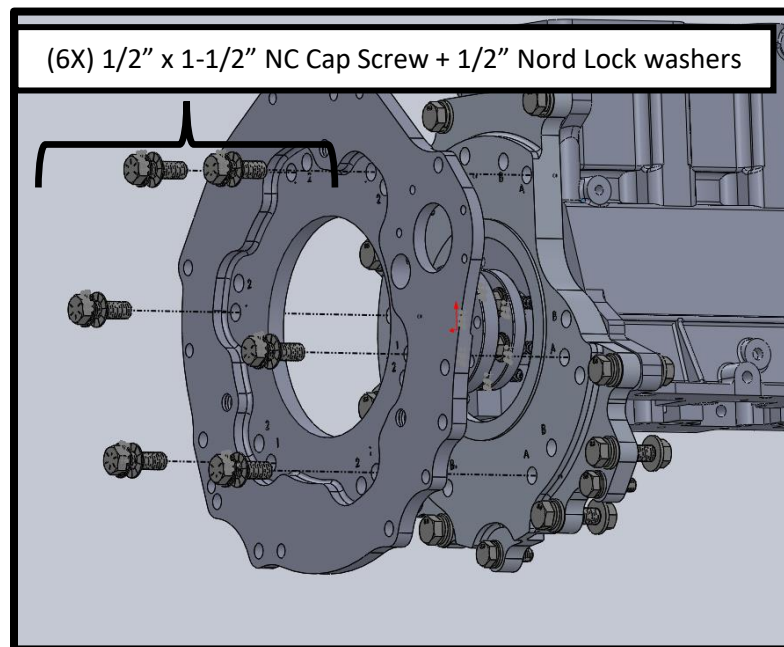

Figure 8: Lubricate the bolts with blue Loctite and torque to **56 ft-lb**.

Installation Manual Special Note:

The products supplied in this kit are manufactured and assembled specifically for this conversion type. The hardware supplied may have more or less bolts than required for your specific application. Modification to components will void any possible warranty or returns. This information is provided as a guide to aid with installation process, it is by no means "complete and exact". We recommend using your vehicle specific Factory Service Manual for additional information.

Flexplate/Flywheel Install

Required parts:

- OEM flexplate or flywheel that matches your transmission
- OEM flexplate or flywheel bolts (not supplied with kit)

- 1) Make sure the flexplate/flywheel mating surfaces are clean, no rust, or debris that will interfere with the mating surfaces on the crank adapter.
- 2) Place the flexplate/flywheel onto crank adapter, there should be very minimal movement between the pilot hole and the crank adapter. In some cases, the pilot hole may not fit onto crank adapter by hand. Try using a rubber mallet to persuade it into place.
- 3) Make sure the flywheel is flush with the crank adapter and there is no gap in the mating faces. Use feeler gauges to check for no gap.
- 4) **If you have an H – style crank adapter, you must check the flywheel bolt lengths are not too long and protrude through crank adapter and bind against the crank studs. Test fit each bolt and verify it does not touch the crank studs. If you find they touch, you can shorten the bolts or use Nord lock washers to space the bolt further out.**
- 5) Secure flexplate/flywheel using the OEM bolts (we do not supply these bolts in our kit). Make sure to follow the factory install and torque specifications. **It is highly recommended to use new bolts with Blue Loctite and use a torque wrench.**

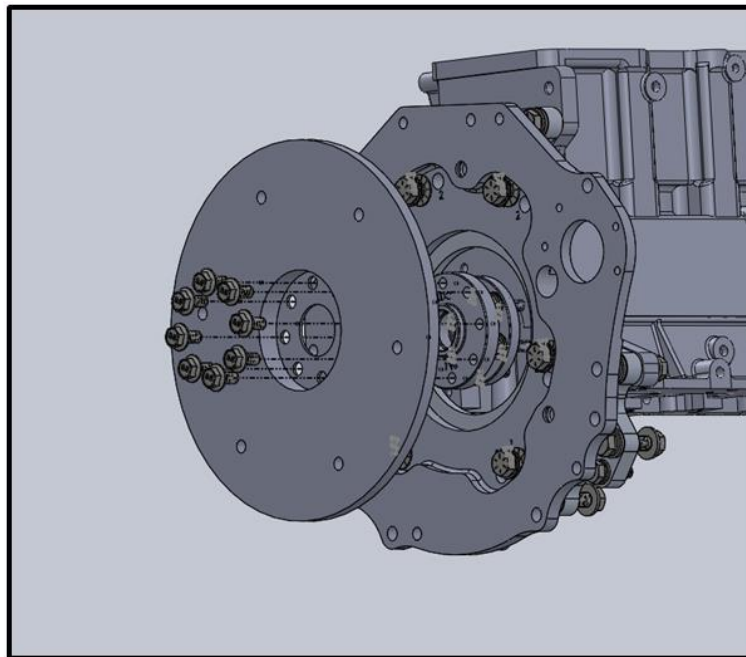

Figure 9: Mounting an OEM flywheel to the crank adapter.

Installation Manual Special Note:

The products supplied in this kit are manufactured and assembled specifically for this conversion type. The hardware supplied may have more or less bolts than required for your specific application. Modification to components will void any possible warranty or returns. This information is provided as a guide to aid with installation process, it is by no means “complete and exact”. We recommend using your vehicle specific Factory Service Manual for additional information.

Starter Motor Install

IMPORTANT NOTE: It is highly recommended that you use a 12 volt **Solenoid Control Relay** to actuate the solenoid. This will guarantee the solenoid is always receiving 12 volts. The solenoid will wear out prematurely or starter motor may underperform if you do not use a solenoid control relay. We recommend using any of these relays: **ND182800-3791, 182800-3820, 182800-3790, 182800-3791**



12V Solenoid Control Relay (182800-3790)



Powermaster starter motor with 12V Solenoid Control Relay attached

Installation Manual Special Note:

The products supplied in this kit are manufactured and assembled specifically for this conversion type. The hardware supplied may have more or less bolts than required for your specific application. Modification to components will void any possible warranty or returns. This information is provided as a guide to aid with installation process, it is by no means "complete and exact". We recommend using your vehicle specific Factory Service Manual for additional information.

- 1) If your adapter kit uses a **Powermaster starter**, attach the starter adapter to the starter motor using the supplied bolts. If your kit uses an **OEM Toyota 4.7L starter motor**, a starter shim and/or spacer may be included.
- 2) It is highly recommended to test fit the starter motor onto the transmission plate **BEFORE** you attach the transmission. This critical step will allow you to verify the starter motor drive gear engages correctly with the ring gear on flexplate/flywheel. You can apply 12 volts to the starter solenoid to extend the drive gear and check correct ring gear engagement.
- 3) Bolt starter motor to transmission plate and torque to **102 in-lbs (8.5 ft-lbs)**. Stop torquing if you feel you are applying too much torque. These are aluminum threads and too much torque can strip the threads. You can apply **Blue Loctite** if desired.
 - a. With the drive gear fully extended onto ring gear, check the gear teeth mesh correctly with approximately 0.03" to 0.06" of clearance between the gear tooth tip of drive gear and root of ring gear.
 - b. With the drive gear retracted, check the distance between the front face of drive gear to face of flexplate/flywheel is between 0.04" and 0.20". If the drive gear rubs on the ring gear in the retracted position, add the provided starter shim (0.060") to move the starter further away from ring gear. If your drive gear is further than 0.20", do not start motor as it may wreck the starter teeth and ring gear, and please contact: info@tdconversions.com
- 4) At this point it is highly recommended that you test start the engine without the transmission attached. This will allow you to verify starter motor engagement on flexplate/flywheel.

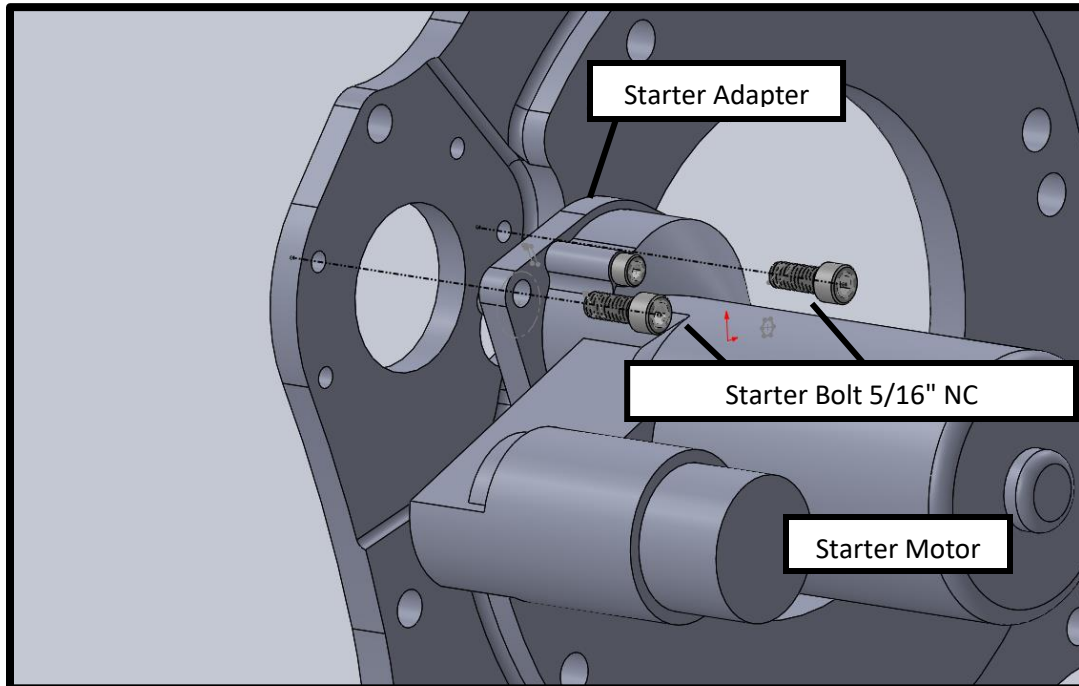

Figure 10: Fastening the starter in place. Torque the 2 starter bolts to **102 in-lbs (8.5 ft-lbs)**.

Installation Manual Special Note:

The products supplied in this kit are manufactured and assembled specifically for this conversion type. The hardware supplied may have more or less bolts than required for your specific application. Modification to components will void any possible warranty or returns. This information is provided as a guide to aid with installation process, it is by no means "complete and exact". We recommend using your vehicle specific Factory Service Manual for additional information.

Install Dowels into Transmission Adapter Plate

Transmission dowels are required to achieve a perfect transmission alignment with the crankshaft.

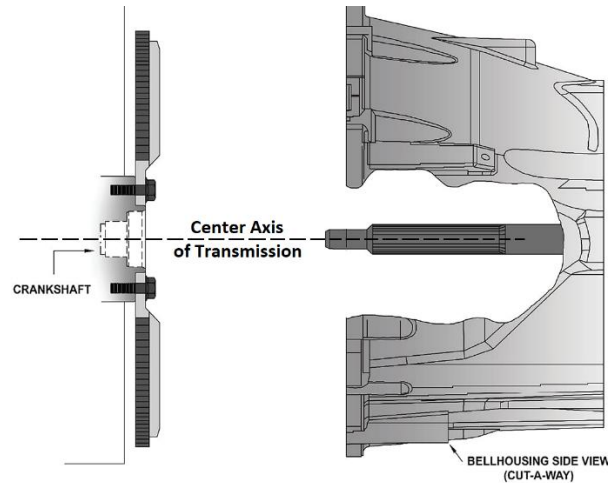

You will need to install the provided dowels into the transmission adapter plate. For most applications the dowels will be a light press fit into the transmission plate.

Install dowels:

1. Use a bench top vise to slowly press the dowels into place. This requires light to moderate force.

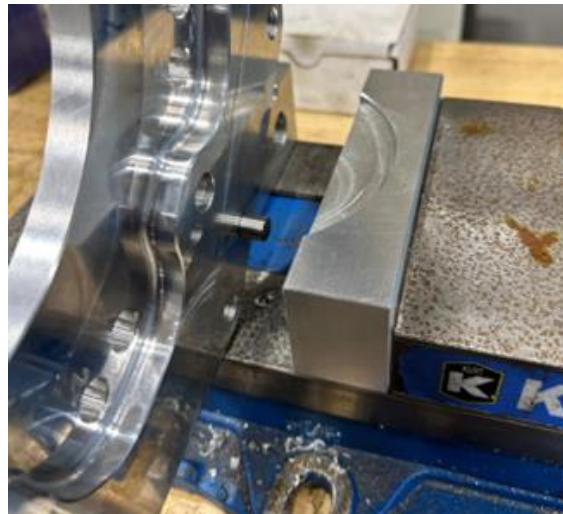

2. Make sure the dowels are seated far enough into the plate. Typically, the dowel will protrude from plate by 0.40 to 0.60". The actual protrusion varies by transmission. Reference the dowel protrusion from your old engine or measure dowel hole depth on your transmission bellhousing.
3. Remove any existing dowels from your transmission bellhousing.

Installation Manual Special Note:

The products supplied in this kit are manufactured and assembled specifically for this conversion type. The hardware supplied may have more or less bolts than required for your specific application. Modification to components will void any possible warranty or returns. This information is provided as a guide to aid with installation process, it is by no means "complete and exact". We recommend using your vehicle specific Factory Service Manual for additional information.



Mate Transmission to Adapter Kit Overview

- 1) Open the transmission hardware pack and organize the hardware based on length and diameter. Each kit will have specific hardware sizes and lengths that match your bellhousing. In some cases, not all the bellhousing holes will be used. Due to the number of bellhousing variations you may have to modify the provided hardware to fit your application.
- 2) On the next page below, you will see examples of hardware stack ups for the common bolts being used in the assembly. There are two securing methods; bolt with nut, or bolt threaded into plate.
- 3) **The location of each bolt is outlined in the next section, “Kit Specific Modifications and Hardware”. Please find your kit and reference the bolt locations before proceeding onto step 4.**
- 4) After you have referenced our hardware location diagrams, proceed to install the transmission, starting with the top 2 thread bolt holes. Double check that you have installed the provided dowels into the transmission adapter plate AND there are no existing dowels in the transmission bellhousing. The dowels are required to achieve a perfect transmission alignment to crankshaft. Align the bellhousing with the dowels on the plate and secure the transmission to the adapter plate.
- 5) Be mindful of the bolts you have remaining and lengths of each. It may take a few minutes to decide which bolts go into which holes. Some bolts may be easier to install when inserted from the transmission side facing forward or from the engine side facing backwards.

For kit specific details and bolt locations, jump to section: “Kit Specific Modifications and Hardware”

Installation Manual Special Note:

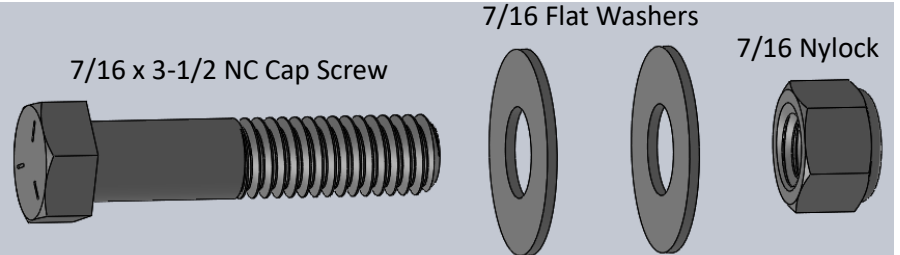
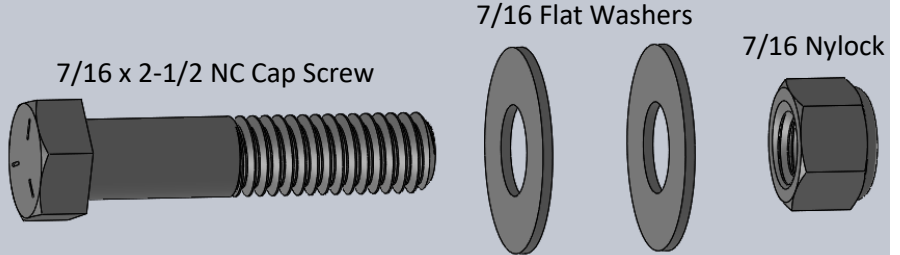
The products supplied in this kit are manufactured and assembled specifically for this conversion type. The hardware supplied may have more or less bolts than required for your specific application. Modification to components will void any possible warranty or returns. This information is provided as a guide to aid with installation process, it is by no means “complete and exact”. We recommend using your vehicle specific Factory Service Manual for additional information.

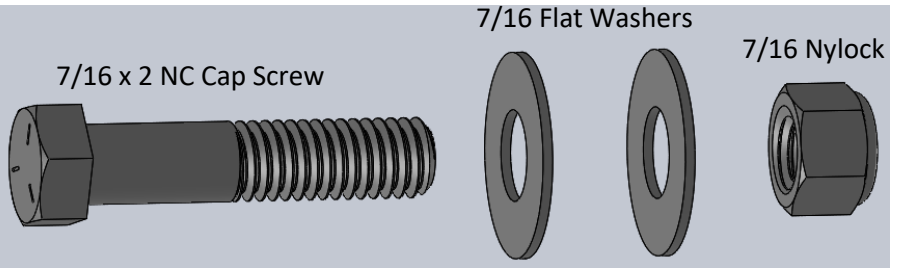
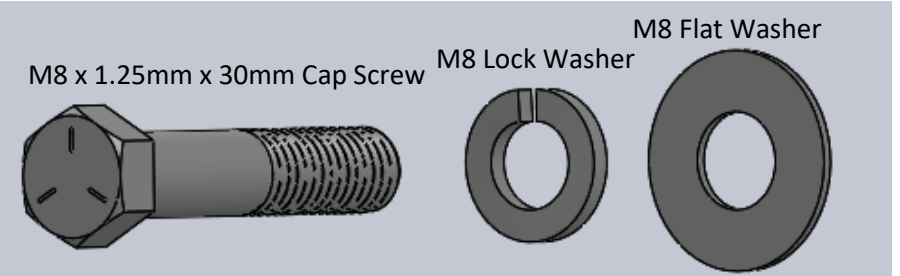
Bolt #	Hardware Assembly Examples	Torque Spec.
13 8 9	 <p>7/16 x 3-1/2 NC Cap Screw</p> <p>7/16 Flat Washers</p> <p>7/16 Nylock</p>	49 ft-lb
1 3 5 6	 <p>7/16 x 2-1/2 NC Cap Screw</p> <p>7/16 Flat Washers</p> <p>7/16 Nylock</p>	49 ft-lb
10 11	 <p>7/16 x 2-3/4 NC Cap Screw</p> <p>7/16 Lock Washer</p> <p>7/16 Flat Washer</p>	35 ft-lb
12	 <p>7/16 x 2 NC Cap Screw</p> <p>7/16 Flat Washers</p> <p>7/16 Nylock</p>	49 ft-lb
1 2 4 7	 <p>M8 x 1.25mm x 30mm Cap Screw</p> <p>M8 Lock Washer</p> <p>M8 Flat Washer</p>	13 ft-lb

Installation Manual Special Note:

The products supplied in this kit are manufactured and assembled specifically for this conversion type. The hardware supplied may have more or less bolts than required for your specific application. Modification to components will void any possible warranty or returns. This information is provided as a guide to aid with installation process, it is by no means "complete and exact". We recommend using your vehicle specific Factory Service Manual for additional information.

Kit Specific Modifications and Hardware

Chevy SBC & LS V8 Adapter Kits

Transmission Bellhousing Hardware

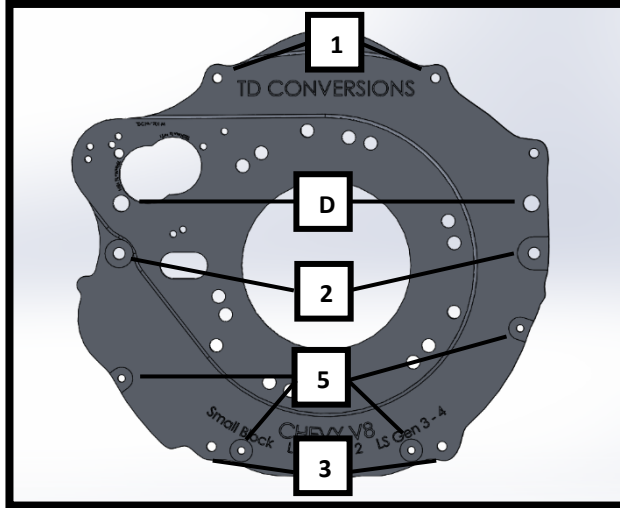

Chevy Small Block Bellhousing Hardware			
Bolt #	Bolt Size	Type of Mounting	Torque Spec.
1	7/16" x 1-3/4" NC	Threaded	35 ft-lb
2	7/16" x 2" NC	Thru	49 ft-lb
3	7/16" x 2-1/4" NC	Threaded	35 ft-lb
4	7/16" x 1-3/4" NC (LS)	Threaded	35 ft-lb
5	1/4" x 1-1/4" NC (SBC)	Threaded	13 ft-lb
D	Dowel		

Bellhousing Modification

1. Remove material from circled area for starter motor gear clearance. See image below.

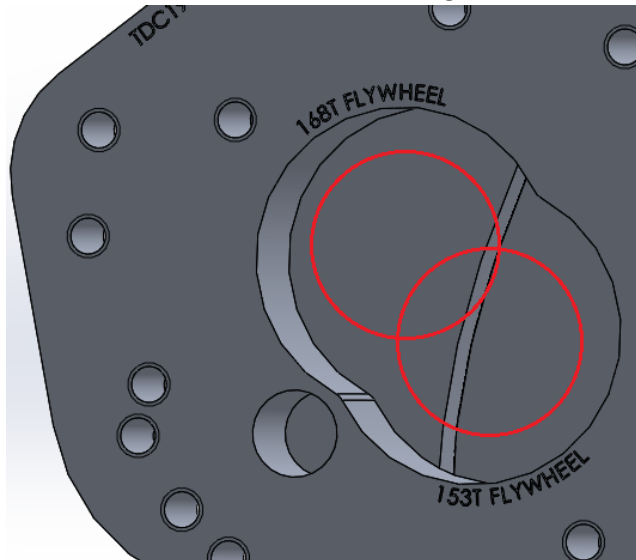

2. You may need to drill holes into bellhousing for the 5/16" starter motor bolts. These will be clearance holes and do not need to be threaded.
3. **Remove the factory dowels from bellhousing. Install new dowels into adapter plate.**

Installation Manual Special Note:

The products supplied in this kit are manufactured and assembled specifically for this conversion type. The hardware supplied may have more or less bolts than required for your specific application. Modification to components will void any possible warranty or returns. This information is provided as a guide to aid with installation process, it is by no means "complete and exact". We recommend using your vehicle specific Factory Service Manual for additional information.

Starter Motor Positions (Powermaster)

- This applies only when using a PowerMaster starter motor compatible adapter kit.
- The starter adapter is nonconcentric to allow starter engagement with 153T and 168T flexplates/flywheels.
 1. Starter motor attaches to starter adapter two ways, see figure below. Attach starter to adapter based on your flexplate/flywheel size.
 2. Attach starter to transmission plate in the correct orientation for your flexplate/flywheel size. Transmission plate has threaded holes for either 153T or 168T. Rotate starter to correct position.

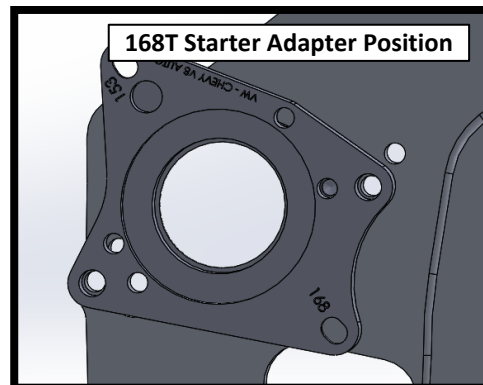
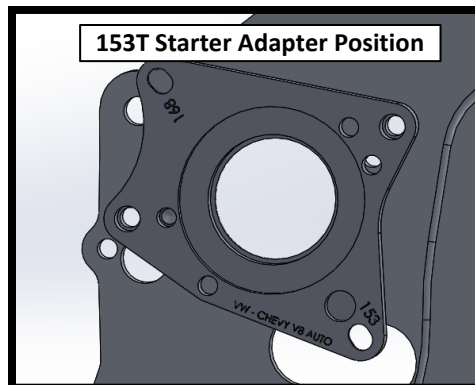
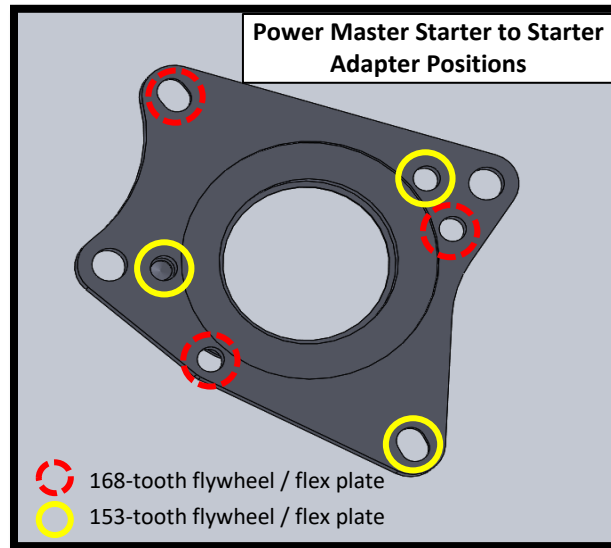

Installation Manual Special Note:

The products supplied in this kit are manufactured and assembled specifically for this conversion type. The hardware supplied may have more or less bolts than required for your specific application. Modification to components will void any possible warranty or returns. This information is provided as a guide to aid with installation process, it is by no means "complete and exact". We recommend using your vehicle specific Factory Service Manual for additional information.

Starter Motor Notes (Toyota 4.7 starter)

- The mounting positions below are for Toyota 4.7 starter motor compatible adapter kits.
- This transmission plate can be used with all Chevy V8 transmission that use 168T or 153T flexplates/flywheels. Use the starter hole that applies to your application.
- The starter motor can be rotated to multiple clocking positions.
- Automatic transmission (SBC): a 0.120" starter motor spacer is required for proper ring gear engagement.
- Automatic transmission (LS Gen 3 + 4): no starter motor spacer required
- Manual transmissions (SBC and LS Gen 3 + 4): no starter motor spacer required
- The Toyota 4.7 starter motor requires a 12-pitch pinion gear (provided with kit). The OEM 10-pitch pinion cannot be used with this kit (only a concern when replacing starter motor)

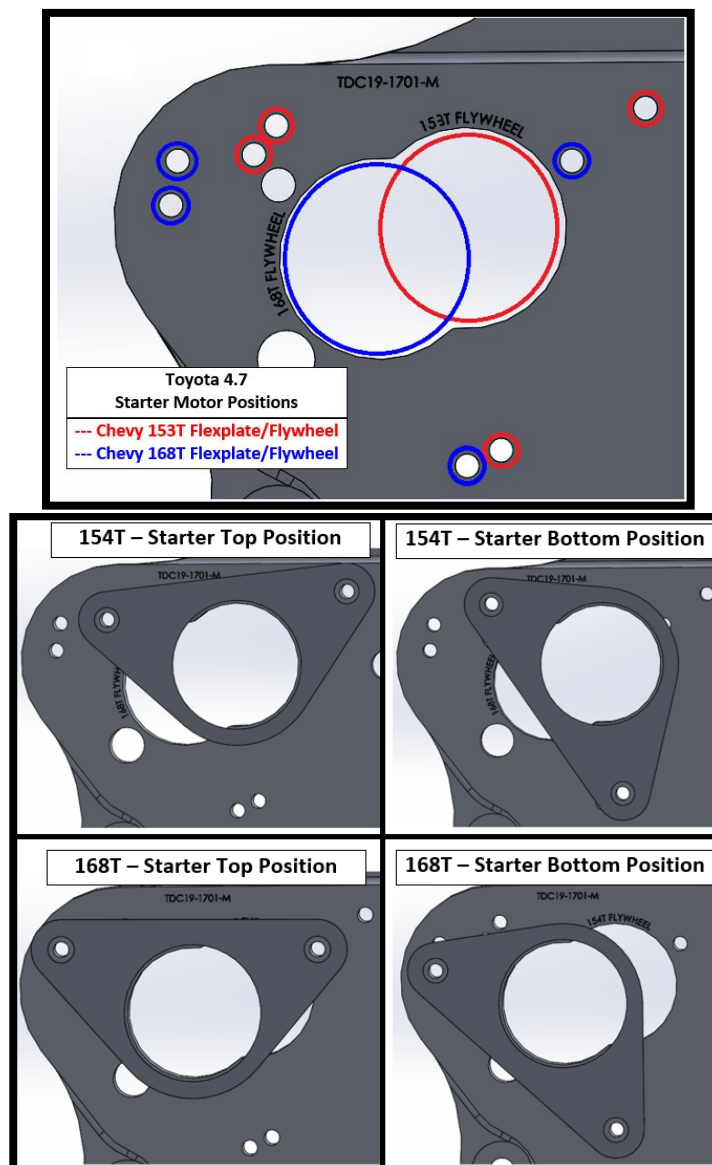

Installation Manual Special Note:

The products supplied in this kit are manufactured and assembled specifically for this conversion type. The hardware supplied may have more or less bolts than required for your specific application. Modification to components will void any possible warranty or returns. This information is provided as a guide to aid with installation process, it is by no means "complete and exact". We recommend using your vehicle specific Factory Service Manual for additional information.

Kit Specific Notes

- This kit was specifically designed to replace the Chevy Small block V8 and LS Gen 3 + 4 engine. This kit makes the back of the VW TDI engine look like the engine block it is replacing. This means you can bolt any Chevy Small block V8 or LS Gen 3 + 4 transmission to any VW 4-cylinder TDI engine using this adapter kit.
- Our Chevy V8 kits are broken down into 3 different kits. The only difference between the 3 kits are the crank adapters; 3 different crank adapters.
- Compatible Engines:
 - V6 4.3 90 degree (V6 60 degree, 2.8 3.1 3.4 will not work)
 - V8 5.0L 5.7L
 - Early LS 6.0L 1998-2000 with the 6L80e. This combo has a longer crank hub than the 2001+ gen 3 LS engines. All 2001+ gen 3 & 4 LS crank hubs are 0.400" shorter than previous gen motors.
- Common Engine codes
 - Pre-1986: LE9, LU5, L14, L48, L46, L65, LM1, ZQ3, L81, L82, L83, LT9, LG3, LT1 (pre-1986), LS9 (pre-1986)
 - Post-1986: L98, L03, L05, L30, L31, LB9, LT1 (92-97)
 - (LS Gen 3 + 4, 2001+): LR4, LM4, LM7, L59, LQ4, LQ9, L33, LS1, LS2, LS3, and so on...
- Common Auto Transmissions
 - (pre-1986): SM420, TH350, TH400, 3L80, 3L80HD, 700R4 (pre-1986)
 - (Post-1986 to 1999): 700R4, 4L60, 4L60e, 4L80, 4L80e (1998-2000)
 - (LS Gen 3 + 4, 2001+): 4L60E, 4L65E, 4L70E, 4L80E, 4L90E, 6L80E, 6L90E
- Common Manual Transmissions
 - (Post-1986 to 1999): NV3500, NV4500, Tremec T-5, T56
 - (LS Gen 3 + 4, 2001+): NV4500, T56, TR6060

Installation Manual Special Note:

The products supplied in this kit are manufactured and assembled specifically for this conversion type. The hardware supplied may have more or less bolts than required for your specific application. Modification to components will void any possible warranty or returns. This information is provided as a guide to aid with installation process, it is by no means "complete and exact". We recommend using your vehicle specific Factory Service Manual for additional information.

Chevy 2.2L and 2.8L V6 Adapter Kits

Transmission Bellhousing Hardware

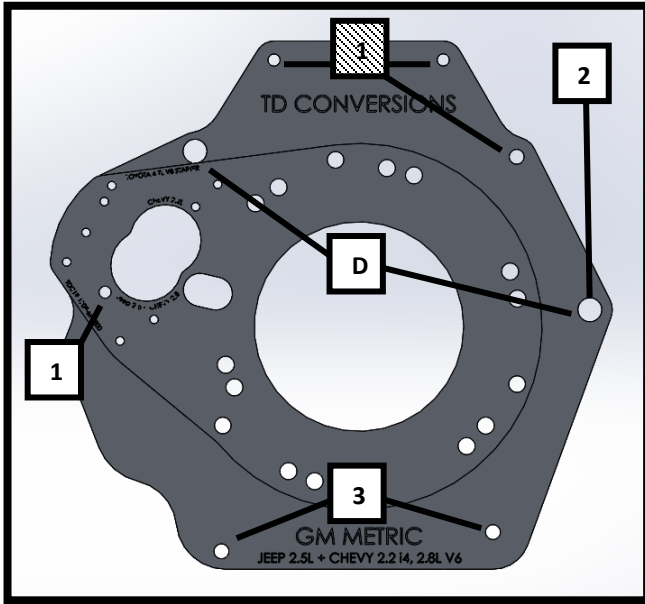

Chevy 2.8L Hardware			
Bolt #	Bolt Size	Type of Mounting	Torque Spec.
1	7/16" x 3" NC CS	Threaded	35 ft-lbs
2	7/16" x 3-1/2" NC CS	Thru	49 ft-lbs
3	7/16" x 2-3/4" NC CS	Thru	49 ft-lbs
D	Dowel	Press fit	

Bolt Orientation

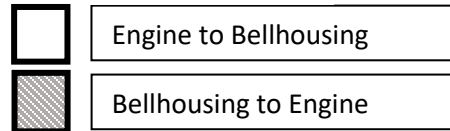

Bellhousing Modification

1. Remove material from the circled areas for starter motor pinion clearance, see photo below.

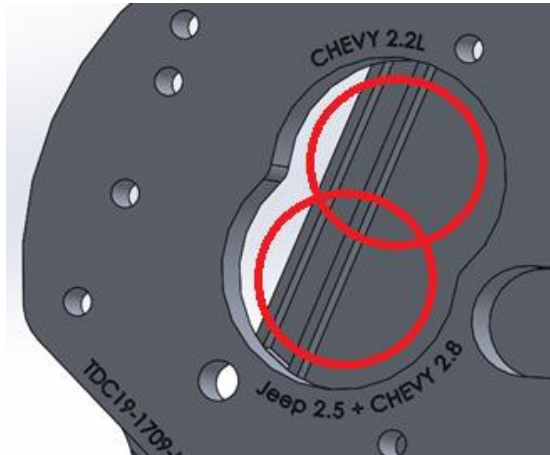

2. Make sure the 5/16" starter motor bolts are clear of the bellhousing. If they interfere, remove material from bellhousing to create clearance. Alternatively, use additional washers to offset bolts.
3. Remove the factory dowels from bellhousing. Install new dowels into adapter plate.

Installation Manual Special Note:

The products supplied in this kit are manufactured and assembled specifically for this conversion type. The hardware supplied may have more or less bolts than required for your specific application. Modification to components will void any possible warranty or returns. This information is provided as a guide to aid with installation process, it is by no means "complete and exact". We recommend using your vehicle specific Factory Service Manual for additional information.

Starter Motor Notes (Toyota 4.7 starter)

- The mounting positions below are for Toyota 4.7 starter motor compatible adapter kits.
- This transmission plate can be used with multiple transmissions. Use the starter hole that applies to your application.
- The starter motor can be rotated to multiple clocking positions.
- For Chevy 2.2 and 2.8 transmissions, a 0.160" starter motor spacer is required for proper ring gear engagement.
- The Toyota 4.7 starter motor requires a 12-pitch pinion gear (provided with kit). The OEM 10-pitch pinion cannot be used with this kit (only a concern when replacing starter motor)

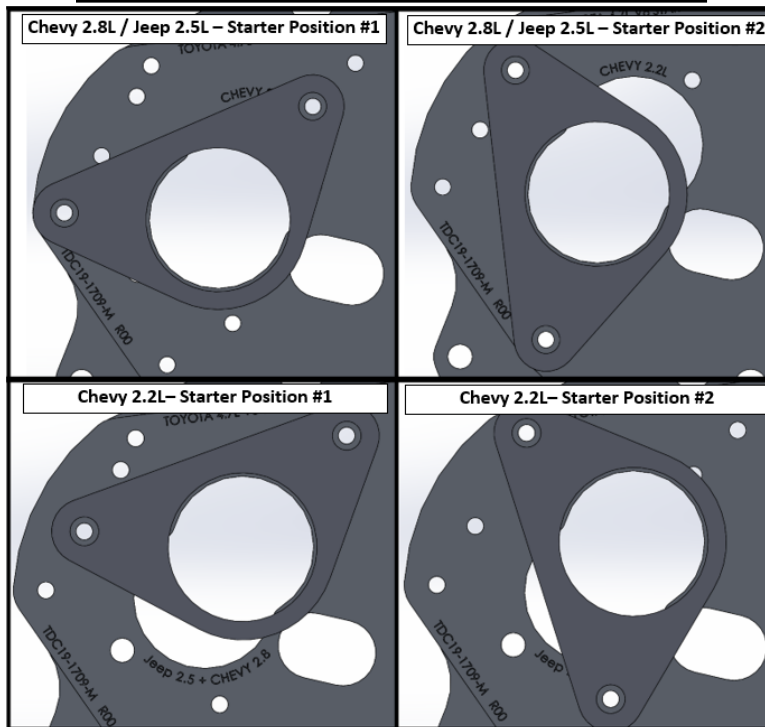
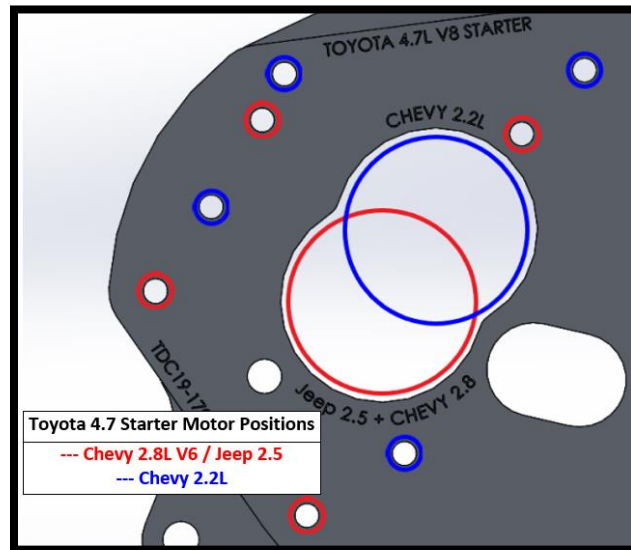

Installation Manual Special Note:

The products supplied in this kit are manufactured and assembled specifically for this conversion type. The hardware supplied may have more or less bolts than required for your specific application. Modification to components will void any possible warranty or returns. This information is provided as a guide to aid with installation process, it is by no means "complete and exact". We recommend using your vehicle specific Factory Service Manual for additional information.

Kit Specific Notes

- This kit was specifically designed to replace the Chevy 2.2 i4 or 2.8 V6 engine. This kit makes the back of the VW TDI engine look like the engine block it is replacing. This means you can bolt any Chevy 2.2L or 2.8 V6 transmission to any VW 4-cylinder TDI engine using this adapter kit.
- Compatible Engine codes:
 - Chevy 2.2L inline 4 cylinder: LN2, L43 (Vortec 2200)
 - All GM 60 degree V6 engines with the GM metric bellhousing
- Compatible Transmissions:
 - NV1500 (manual)
 - 4L60E (non-removable bellhousing, 60 degree V6 GM Metric pattern)
 - All V6 GM metric bellhousing transmissions

Installation Manual Special Note:

The products supplied in this kit are manufactured and assembled specifically for this conversion type. The hardware supplied may have more or less bolts than required for your specific application. Modification to components will void any possible warranty or returns. This information is provided as a guide to aid with installation process, it is by no means “complete and exact”. We recommend using your vehicle specific Factory Service Manual for additional information.

Ford 3.0L V6 Adapter Kits

Transmission Bellhousing Hardware

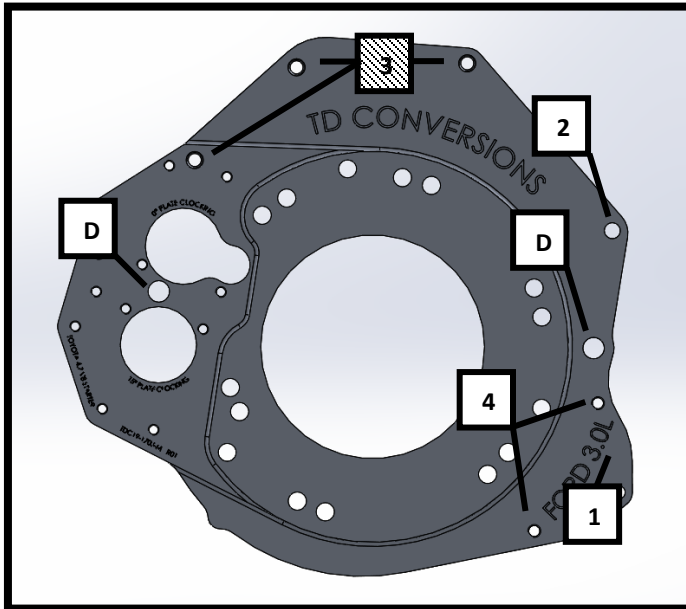

Ford 3L Hardware			
Bolt #	Bolt Size	Type of Mounting	Torque Spec.
1	3/8" x 2-1/4" NC CS	Thru	31 ft-lbs
2	7/16" x 2-1/4" NC CS	Thru	49 ft-lbs
3	7/16" x 1-3/4" NC	Threaded	35 ft-lbs
4	3/8" x 1-3/4" NC CS	Thru	31 ft-lbs
D	Dowel		

Bolt Orientation

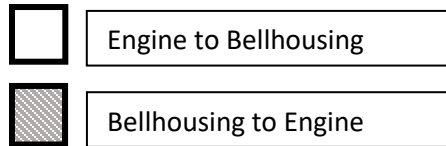

Bellhousing Modification

1. Remove material from the circled area for starter motor clearance, see photo.
2. Make sure the 5/16" starter motor bolts are clear of the bellhousing. If they interfere, remove material from bellhousing to create clearance. Alternatively, use additional washers to offset bolts.
3. **Remove the factory dowels from bellhousing. Install new dowels into adapter plate.**

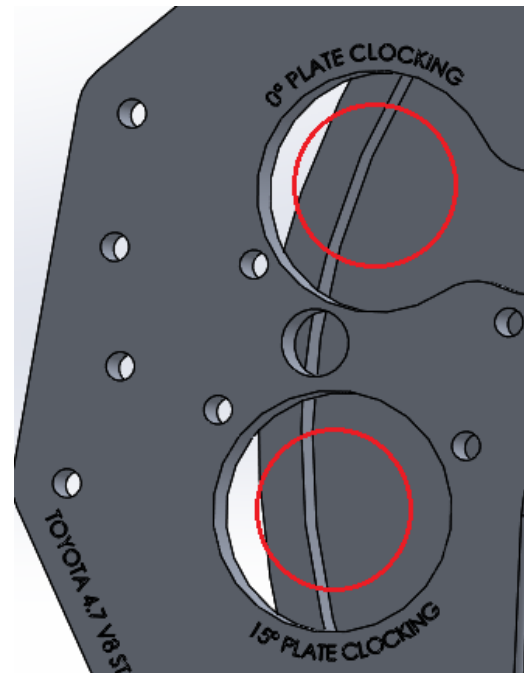

Installation Manual Special Note:

The products supplied in this kit are manufactured and assembled specifically for this conversion type. The hardware supplied may have more or less bolts than required for your specific application. Modification to components will void any possible warranty or returns. This information is provided as a guide to aid with installation process, it is by no means "complete and exact". We recommend using your vehicle specific Factory Service Manual for additional information.

Starter Motor Notes (Toyota 4.7 starter)

- The mounting positions below are for Toyota 4.7 starter motor compatible adapter kits.
- There are two starter hole locations. The top hole is used when engine is clocked at 0 degrees. The bottom hole is used when engine is clocked at 15 degrees. Use the starter hole that applies to your application.
- The starter motor can be rotated to multiple clocking positions.
- No starter motor spacer required
- The Toyota 4.7 starter motor requires a 12-pitch pinion gear (provided with kit). The OEM 10-pitch pinion cannot be used with this kit (only a concern when replacing starter motor)

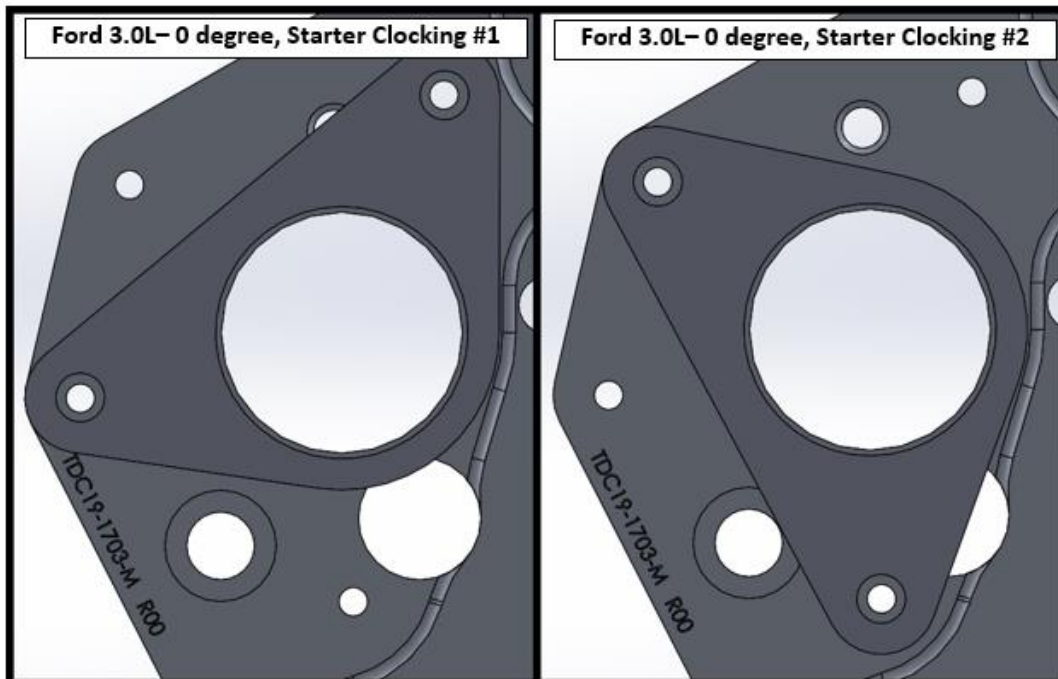

Kit Specific Notes

- This kit was specifically designed to replace the Ford 3.0L V6 (Vulcan) engine. This kit makes the back of the VW TDI engine look like the engine block it is replacing. This means you can bolt any Ford 3.0L V6 (Vulcan) transmission to any VW 4-cylinder TDI engine using this adapter kit.
- Compatible Engine codes:
 - Ford 3.0L (OHV Vulcan V6), Mazda 3.0L (OHV Vulcan V6)
- Compatible Auto Transmission:
 - 4R44E, 5R44E (3.0L Bellhousing)
- Compatible Manual Transmission:
 - M50D-R1 (3.0L Bellhousing)
 - M50D-R1HD (3.0L Bellhousing)
- Compatible vehicle make and models:
 - Ford Ranger (3.0L V6 Vulcan): 1991 to 2011
 - Mazda B3000 (3.0L V6 Vulcan): 1993 to present (2022)

Installation Manual Special Note:

The products supplied in this kit are manufactured and assembled specifically for this conversion type. The hardware supplied may have more or less bolts than required for your specific application. Modification to components will void any possible warranty or returns. This information is provided as a guide to aid with installation process, it is by no means “complete and exact”. We recommend using your vehicle specific Factory Service Manual for additional information.

Ford 4.0L V6 Adapter Kits

Transmission Bellhousing Hardware

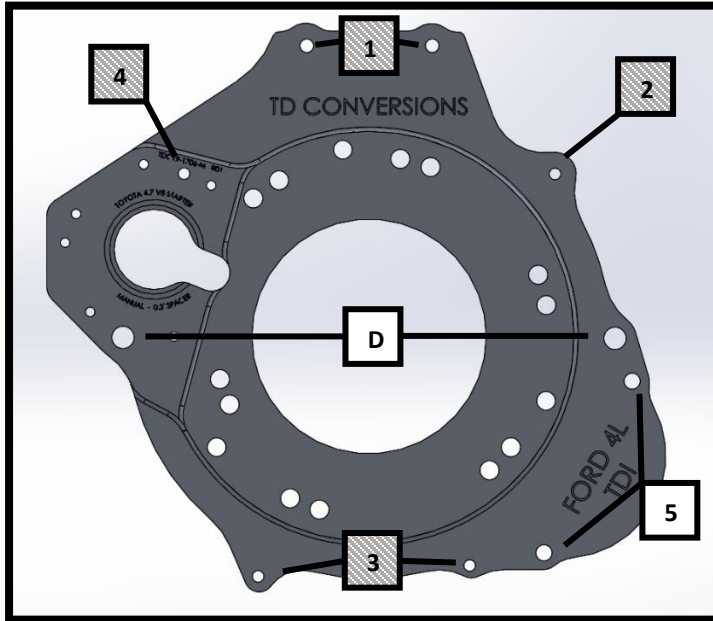

Ford 4L Hardware			
Bolt #	Bolt Size	Type of Mounting	Torque Spec.
1	7/16" x 2-1/4" NC CS	Threaded	35 ft-lbs
2	3/8" x 2-1/4" NC CS	Threaded	35 ft-lbs
3	3/8" x 2-1/4" NC CS	Threaded	35 ft-lbs
4	3/8" x 2-1/2" NC CS	Threaded	35 ft-lbs
5	M10 x 1.5 x 35mm	Thru	33 ft-lbs
D	Dowel	Hollow	

Bolt Orientation

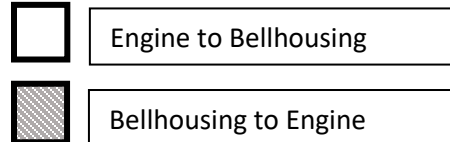

Bellhousing Modification

1. Remove material from the circled area for starter motor clearance, see image below.

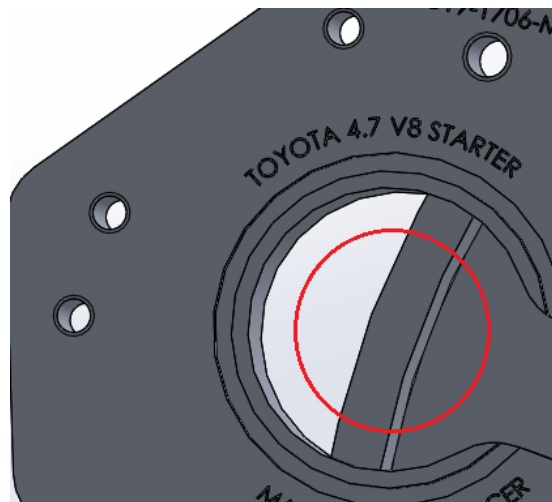

2. Make sure the 5/16" starter motor bolts are clear of the bellhousing. If they interfere, remove material from bellhousing to create clearance. Alternatively, use additional washers to offset bolts.
3. Remove the factory dowels from bellhousing. Install new dowels into adapter plate.

Installation Manual Special Note:

The products supplied in this kit are manufactured and assembled specifically for this conversion type. The hardware supplied may have more or less bolts than required for your specific application. Modification to components will void any possible warranty or returns. This information is provided as a guide to aid with installation process, it is by no means "complete and exact". We recommend using your vehicle specific Factory Service Manual for additional information.

Starter Motor Notes (Toyota 4.7 starter)

- The mounting positions shown are for Toyota 4.7 starter motor compatible adapter kits.
- The starter motor can be rotated to multiple clocking positions.
- MANUAL transmissions: use the provided 0.24" starter spacer
- AUTO transmissions: do not use starter spacer, bolt starter directly to transmission plate.
- The Toyota 4.7 starter motor requires a 12 pitch pinion gear, the OEM 10 pitch pinion cannot be used with this kit.

Kit Specific Notes

- This kit is specifically designed to replace the Ford 2.8, 2.9, and 4.0L V6 "Cologne" engine. The adapter plate makes the back of the VW TDI engine look like the engine block it is replacing. This means you can bolt any Ford 2.8, 2.9, and 4.0L V6 transmission to any VW 4-cylinder TDI engine using this adapter kit.
- Compatible Engines: Ford Cologne engine family - 2.8L V6, 2.9L V6, 4.0L V6 (OHV and SOHC)
 - OHV (1990 - 2000) (VIN Code X)
 - SOHC (2001 - 2007) (VIN Code E)
 - *Ford Explorer OHV and SOHC (1997 - 2000), SOHC only (2001+)
- **If you are replacing a Ford 4.0L V6 SOHC 1998+ (with 8 bolt flywheel), you will need to use a 6 bolt flywheel and clutch kit from the 4.0L V6 OHV (1990-1997).**
- Compatible Auto Transmission: 4R55E, 5R55E
- Compatible Manual Transmission
 - M50D-R1 (4.0L Bellhousing) 1990-2000
 - M50D-R1HD (4.0L Bellhousing) 2001-2011
- Flywheel recommendation (4.0L, 6 bolt, 1990-1997)
 - LUK LFW156
- Clutch kit recommendation (4.0L, 6 bolt, 1990-1997)
 - LUK 07905 {#07-905} RepSet®; Heavy-Duty
- M50D-R1 and M50D-R1HD manual transmissions have been proven to handle over 400 ft-lbs of torque.

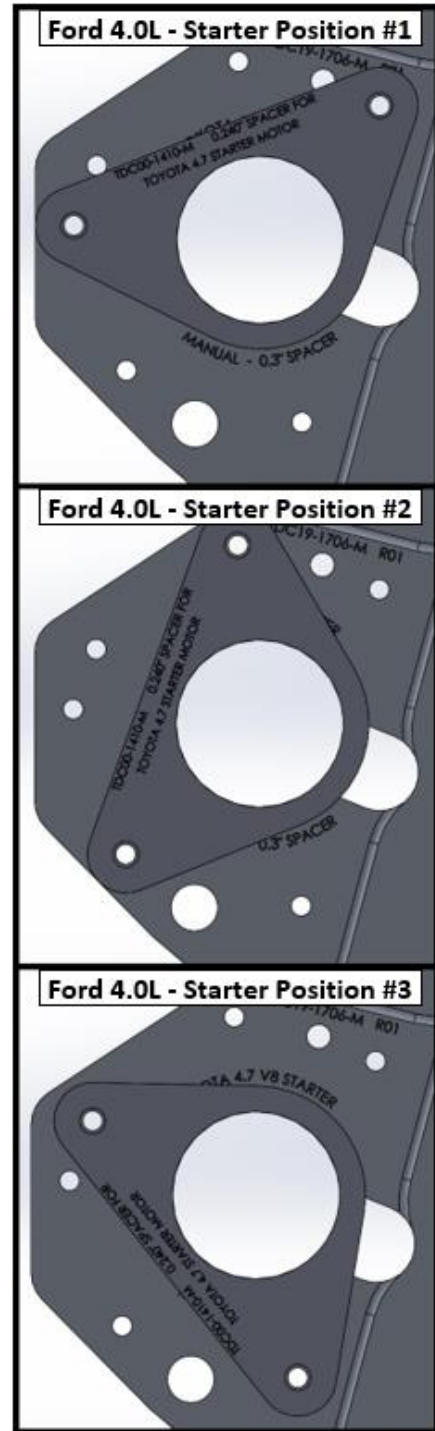

Installation Manual Special Note:

The products supplied in this kit are manufactured and assembled specifically for this conversion type. The hardware supplied may have more or less bolts than required for your specific application. Modification to components will void any possible warranty or returns. This information is provided as a guide to aid with installation process, it is by no means "complete and exact". We recommend using your vehicle specific Factory Service Manual for additional information.

Ford Small Block V8 Adapter Kits

Transmission Bellhousing Hardware

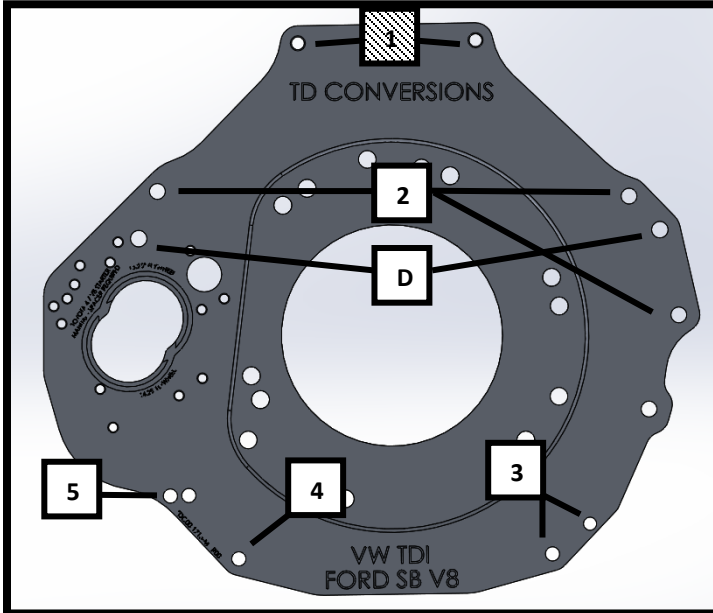

Ford 4L Hardware			
Bolt #	Bolt Size	Type of Mounting	Torque Spec.
1	7/16" x 2" NC CS	Threaded	35 ft-lbs
2	7/16" x 3" NC CS	Thru	49 ft-lbs
3	5/16" x 1-1/4" NC CS	Thru	30 ft-lbs
4	3/8" x 1-1/4" NC CS	Thru	35 ft-lbs
5	3/8" x 1-3/4" NC CS	Thru	35 ft-lbs
D	Dowel	Solid	

Bolt Orientation

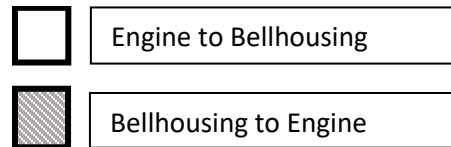

Bellhousing Modification

1. Remove material from the circled area for starter motor clearance, see image.
2. Make sure the 5/16" starter motor bolts are clear of the bellhousing. If they interfere, remove material from bellhousing to create clearance. Alternatively, use additional washers to offset bolts.
3. Remove the factory dowels from bellhousing. Install new dowels into adapter plate.

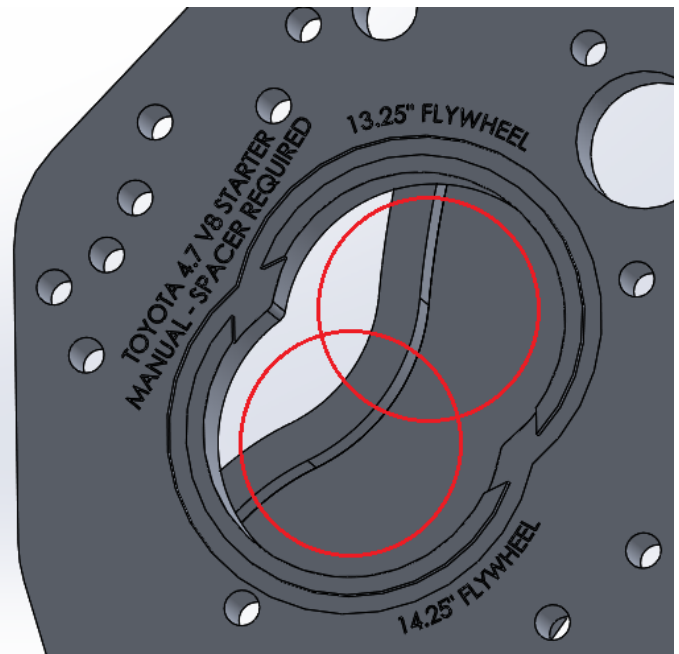

Installation Manual Special Note:

The products supplied in this kit are manufactured and assembled specifically for this conversion type. The hardware supplied may have more or less bolts than required for your specific application. Modification to components will void any possible warranty or returns. This information is provided as a guide to aid with installation process, it is by no means "complete and exact". We recommend using your vehicle specific Factory Service Manual for additional information.

Starter Motor Notes (Toyota 4.7 starter)

- The mounting positions shown are for Toyota 4.7 starter motor compatible adapter kits.
- This transmission plate can be used with all Ford small block V8 transmissions that use a 13.25" or 14.25" flexplates/flywheels. Use the starter hole that applies to your application.
- The starter motor can be rotated to multiple clocking positions.
- MANUAL transmissions: use the provided 0.35" starter motor spacer (press spacer into groove)
- AUTO transmissions: do not use starter spacer, bolt starter directly to transmission plate.
- The Toyota 4.7 starter motor requires a 12 pitch pinion gear, the OEM 10 pitch pinion cannot be used with this kit.

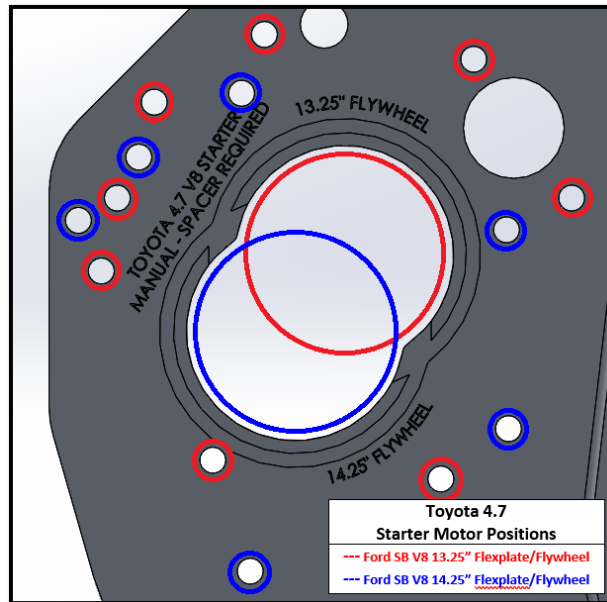

Starter Motor Clocking Positions

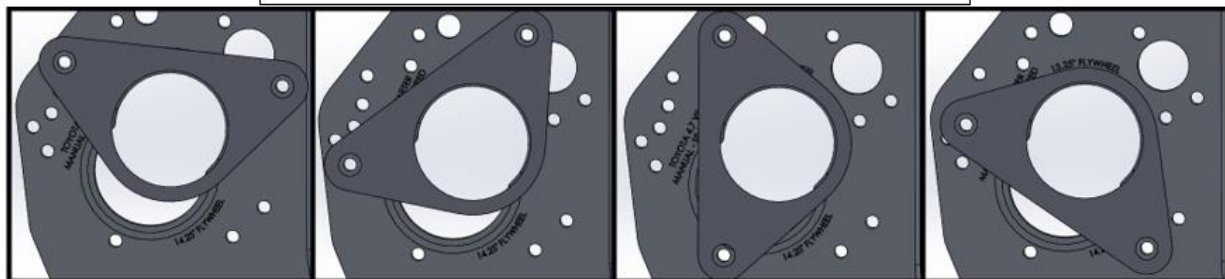

Installation Manual Special Note:

The products supplied in this kit are manufactured and assembled specifically for this conversion type. The hardware supplied may have more or less bolts than required for your specific application. Modification to components will void any possible warranty or returns. This information is provided as a guide to aid with installation process, it is by no means "complete and exact". We recommend using your vehicle specific Factory Service Manual for additional information.

Kit Specific Notes

- This kit is specifically designed to replace any Ford small block V8 engine. The adapter plate makes the back of the VW TDI engine look like the engine block it is replacing. This means you can bolt any Ford small block V8 transmission to any VW 4-cylinder TDI engine using this adapter kit.
- Common Engines:
 - 221, 255, 260, 289, 302, and 351 (Windsor) cubic inch engines
 - Ford Mustang 3.8L (1998-2004)
- Compatible vehicles:
 - Ford vehicles between 1962 and 2000 with Ford Small Block V8 transmission
 - Ford Mustang V6 3.8L (1998-2004) with the hybrid 4R70w (Ford SB V8 bellhousing with 4R70w transmission box)
- **THIS KIT IS NOT COMPATIBLE WITH THE NEWER FORD MODULAR V8 TRANSMISSIONS.**

Installation Manual Special Note:

The products supplied in this kit are manufactured and assembled specifically for this conversion type. The hardware supplied may have more or less bolts than required for your specific application. Modification to components will void any possible warranty or returns. This information is provided as a guide to aid with installation process, it is by no means “complete and exact”. We recommend using your vehicle specific Factory Service Manual for additional information.

JEEP 4.0L, 4.2L, and AMC V8 Adapter Kits

Transmission Bellhousing Hardware

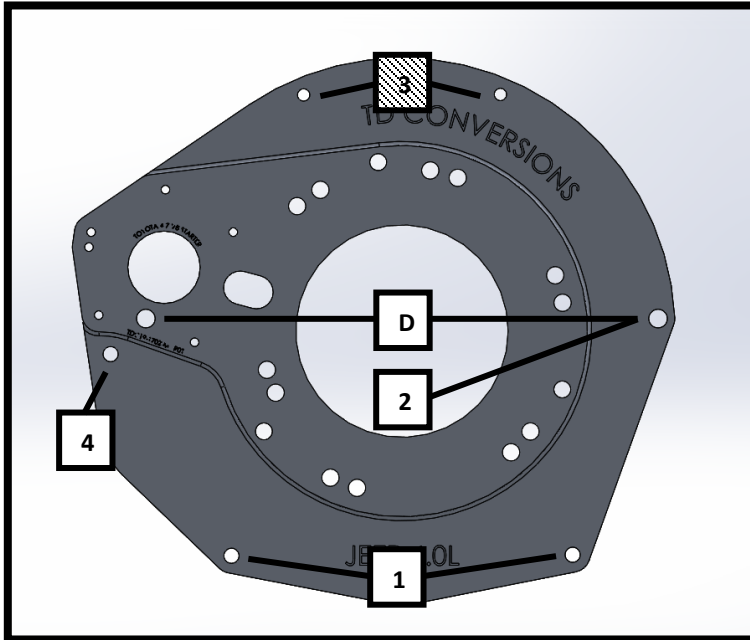

Jeep 4L Hardware			
Bolt #	Bolt Size	Type of Mounting	Torque Spec.
1	7/16" x 2-1/4" NC CS	Thru	49 ft-lb
2	3/8" x 3" NC CS	Thru	35 ft-lb
3	7/16" x 2" NC CS	Threaded	35 ft-lb
4	7/16" x 1-1/2" NC CS	Thru	49 ft-lb
D	Dowel	Hollow	

Bolt Orientation

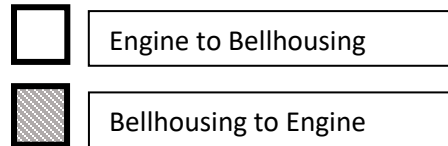

Bellhousing Modification

1. Remove material from the circled area for starter motor clearance, see image below.

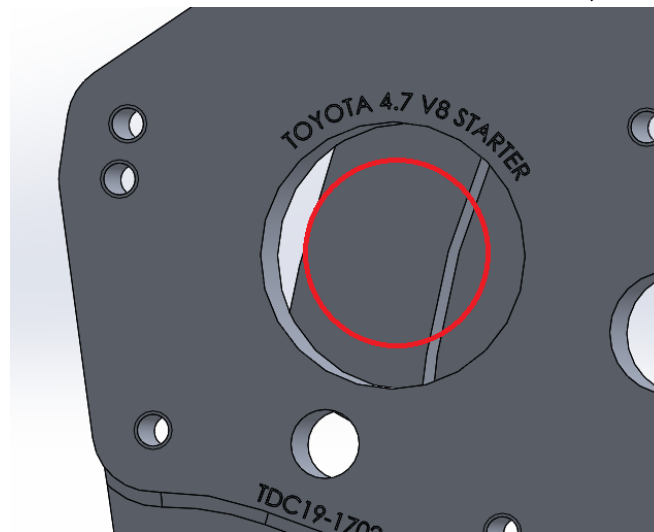

2. Make sure the 5/16" starter motor bolts are clear of the bellhousing. If they interfere, remove material from bellhousing to create clearance. Alternatively, use additional washers to offset bolts.
3. **Remove the factory dowels from bellhousing. Install new dowels into adapter plate.**

Installation Manual Special Note:

The products supplied in this kit are manufactured and assembled specifically for this conversion type. The hardware supplied may have more or less bolts than required for your specific application. Modification to components will void any possible warranty or returns. This information is provided as a guide to aid with installation process, it is by no means "complete and exact". We recommend using your vehicle specific Factory Service Manual for additional information.

Starter Motor Notes (Toyota 4.7 starter)

- The mounting positions shown below are for Toyota 4.7 starter motor compatible adapter kits.
- This transmission plate can be used with any Jeep 4.0L, 4.2L, or AMC V8 Gen 2 + 3 (1966-1991) transmission.
- The starter motor can be rotated to multiple clocking positions.
- No starter motor spacer required
- The Toyota 4.7 starter motor requires a 12 pitch pinion gear, the OEM 10 pitch pinion cannot be used with this kit.

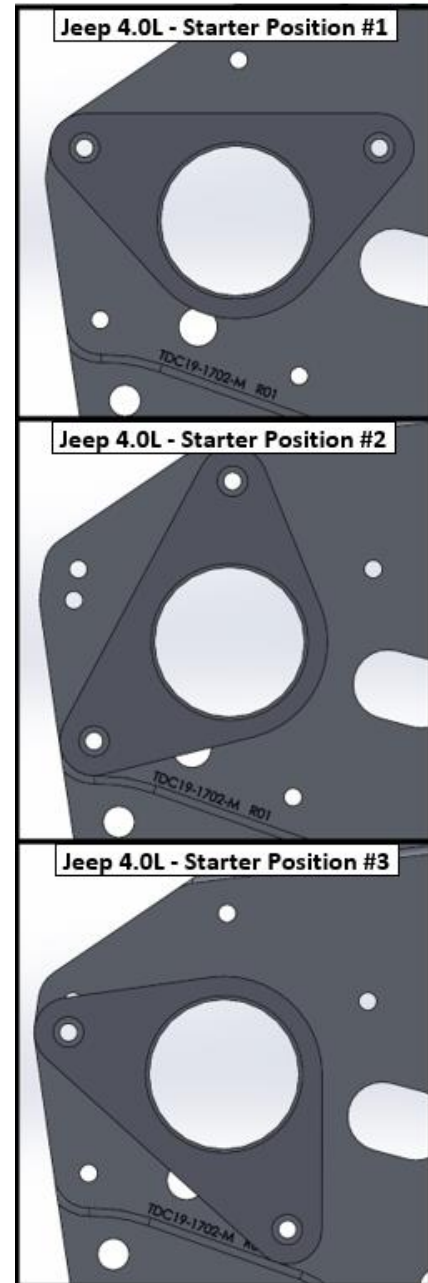

Installation Manual Special Note:

The products supplied in this kit are manufactured and assembled specifically for this conversion type. The hardware supplied may have more or less bolts than required for your specific application. Modification to components will void any possible warranty or returns. This information is provided as a guide to aid with installation process, it is by no means "complete and exact". We recommend using your vehicle specific Factory Service Manual for additional information.

JEEP 3.8L Adapter Kits

Transmission Bellhousing Hardware

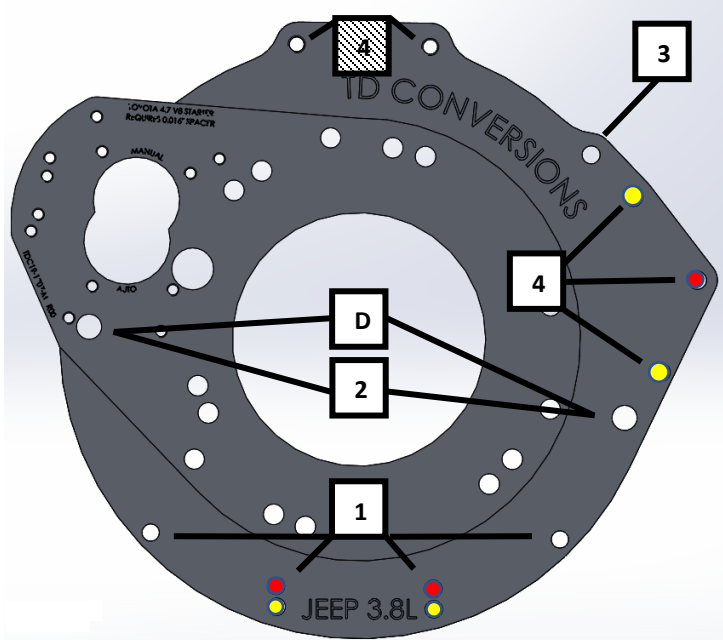

Jeep 3.8L Hardware			
Bolt #	Bolt Size	Type of Mounting	Torque Spec.
1	M10 x 1.5 x 35mm	Threaded	35 ft-lb
2	M12 x 1.75 x 40mm	Threaded	45 ft-lb
3	7/16" x 2-1/4" NC CS	Thru	49 ft-lb
4	7/16" x 2" NC CS	Threaded	35 ft-lb
D	Dowel	Hollow	

Bolt Orientation

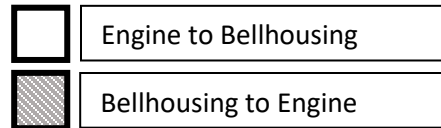

Transmission Specific

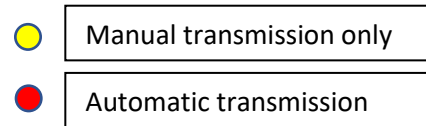

Bellhousing Modification

1. Remove material from the circled area for starter motor clearance, see image below.

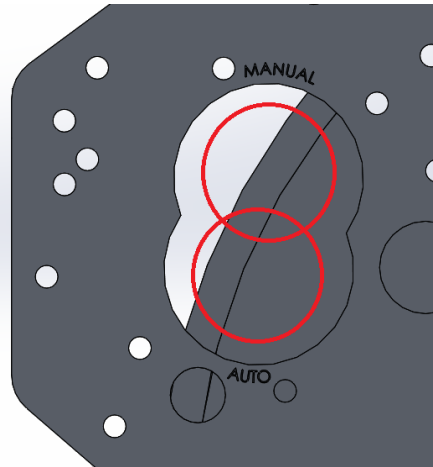

2. Make sure the 5/16" starter motor bolts are clear of the bellhousing. If they interfere, remove material from bellhousing to create clearance. Alternatively, use additional washers to offset bolts.
3. **Remove the factory dowels from bellhousing. Install new dowels into adapter plate.**

Installation Manual Special Note:

The products supplied in this kit are manufactured and assembled specifically for this conversion type. The hardware supplied may have more or less bolts than required for your specific application. Modification to components will void any possible warranty or returns. This information is provided as a guide to aid with installation process, it is by no means "complete and exact". We recommend using your vehicle specific Factory Service Manual for additional information.

Starter Motor Notes (Toyota 4.7 starter)

- The mounting positions shown below are for Toyota 4.7 starter motor compatible adapter kits.
- This transmission plate can be used with any Jeep 3.8L transmission. The starter position is different for manual or auto transmissions. Use the hole that matches your transmission type.
- The starter motor can be rotated to multiple clocking positions.
- A 0.060" starter motor spacer is required for manual and automatic transmissions.
- The Toyota 4.7 starter motor requires a 12 pitch pinion gear, the OEM 10 pitch pinion cannot be used with this kit.

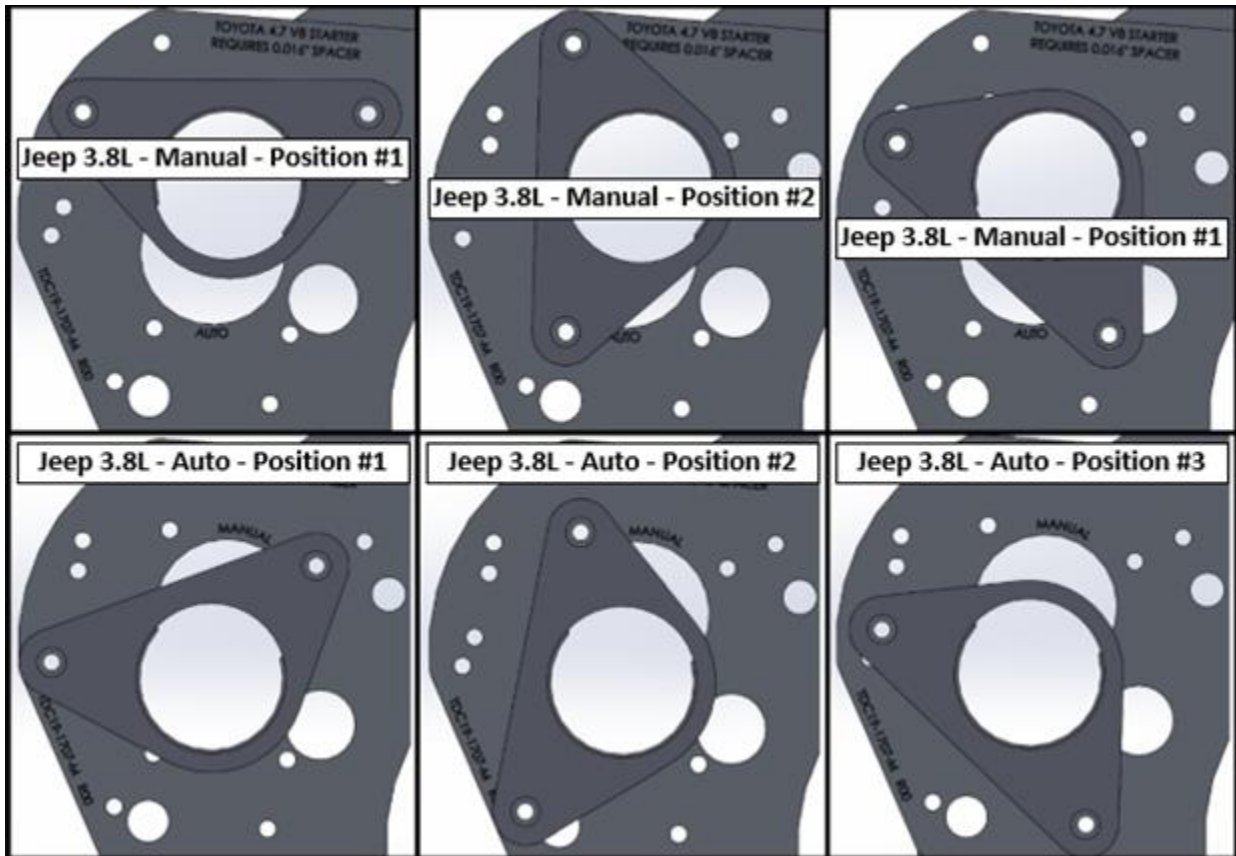
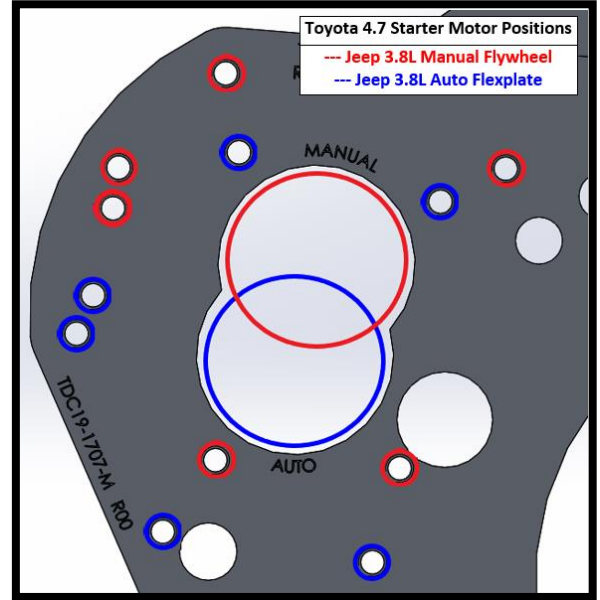

Installation Manual Special Note:

The products supplied in this kit are manufactured and assembled specifically for this conversion type. The hardware supplied may have more or less bolts than required for your specific application. Modification to components will void any possible warranty or returns. This information is provided as a guide to aid with installation process, it is by no means "complete and exact". We recommend using your vehicle specific Factory Service Manual for additional information.

JEEP 3.6L Adapter Kits

Transmission Bellhousing Hardware

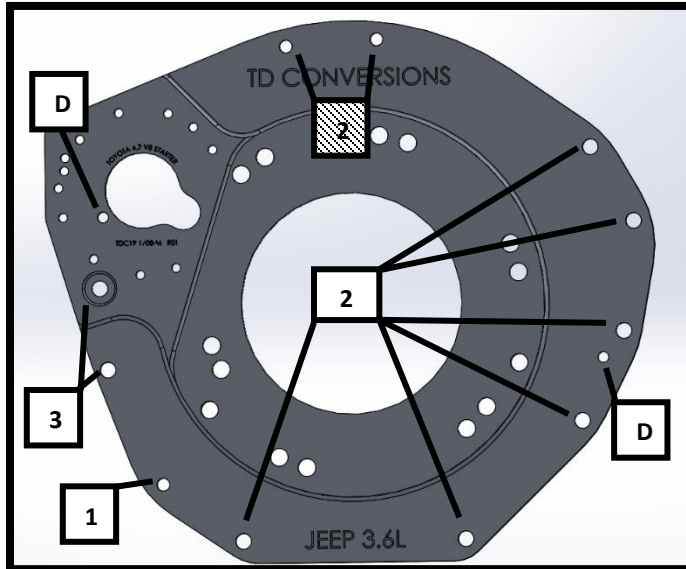

Jeep 3.6L Hardware			
Bolt #	Bolt Size	Type of Mounting	Torque Spec.
1	7/16" x 1-1/2" NC CS	Threaded	35 ft-lb
2	7/16" x 2" NC CS	Thru	49 ft-lb
3	M10 x 1.5 x 45mm CS	Threaded	35 ft-lb
D	Dowel	Solid	

Bolt Orientation

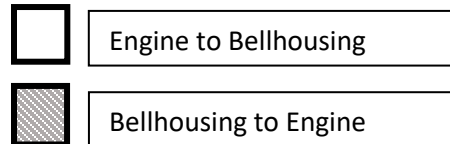

Bellhousing Modification

1. Remove material from the circled area for starter motor clearance, see photo below.

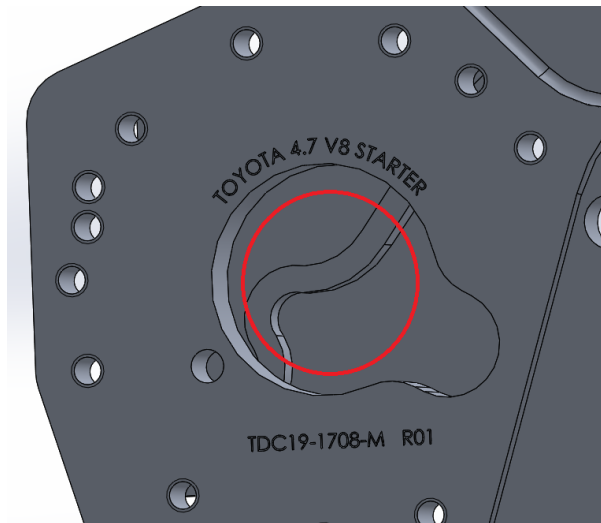

2. You may need to drill clearance holes into bellhousing for the 5/16" starter motor bolts. These will be clearance holes and do not need to be threaded.
3. Remove the factory dowels from the bellhousing. Our transmission adapter plate will have the dowels pre-installed for you.

Installation Manual Special Note:

The products supplied in this kit are manufactured and assembled specifically for this conversion type. The hardware supplied may have more or less bolts than required for your specific application. Modification to components will void any possible warranty or returns. This information is provided as a guide to aid with installation process, it is by no means "complete and exact". We recommend using your vehicle specific Factory Service Manual for additional information.

Starter Motor Notes (Toyota 4.7 starter)

- The mounting positions shown below are for Toyota 4.7 starter motor compatible adapter kits.
- This transmission plate can be used with any Jeep 3.6L transmission.
- The starter motor can be rotated to multiple clocking positions.
- This kit utilizes a 10-pitch starter motor pinion gear. You do not need to swap to the 12-pitch.

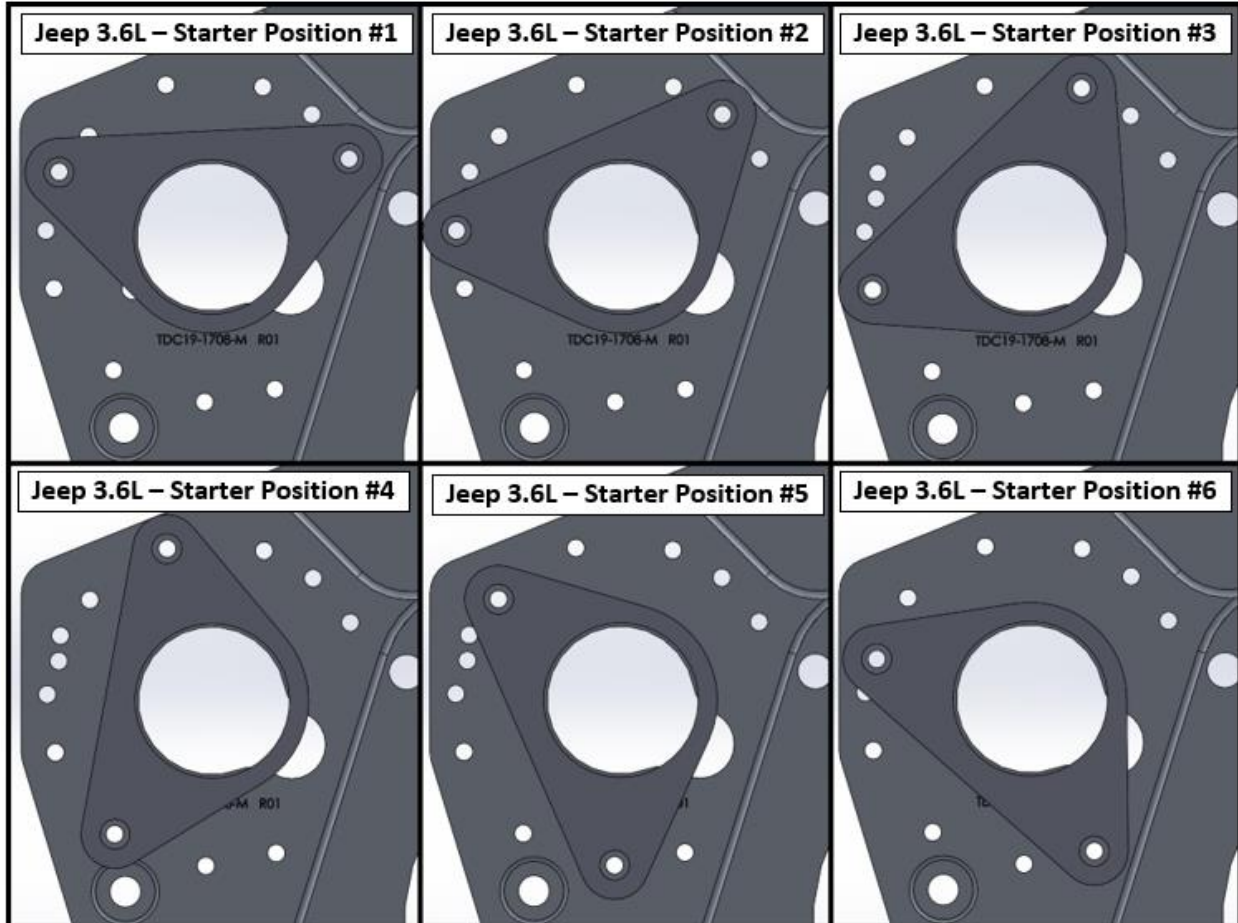

Installation Manual Special Note:

The products supplied in this kit are manufactured and assembled specifically for this conversion type. The hardware supplied may have more or less bolts than required for your specific application. Modification to components will void any possible warranty or returns. This information is provided as a guide to aid with installation process, it is by no means "complete and exact". We recommend using your vehicle specific Factory Service Manual for additional information.

Jeep 2.5L Adapter Kits

Transmission Bellhousing Hardware

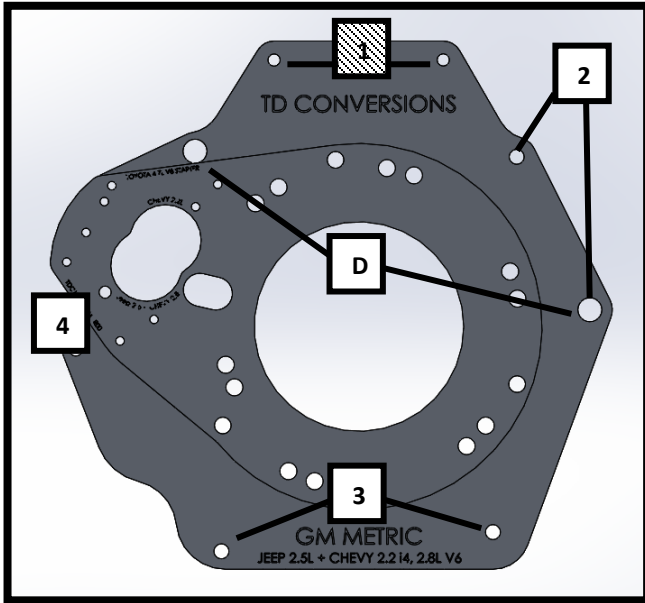

Chevy 2.8L Hardware			
Bolt #	Bolt Size	Type of Mounting	Torque Spec.
1	7/16" x 2" NC CS	Threaded	35 ft-lbs
2	7/16" x 4" NC CS	Thru	49 ft-lbs
3	7/16" x 3" NC CS	Thru	49 ft-lbs
4	7/16" x 1-1/2" NC CS	Threaded	35 ft-lbs
D	Dowel		

Bolt Orientation

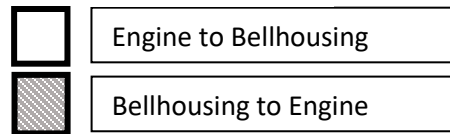

Bellhousing Modification

1. Remove material from the circled area for starter motor clearance, see photo below.

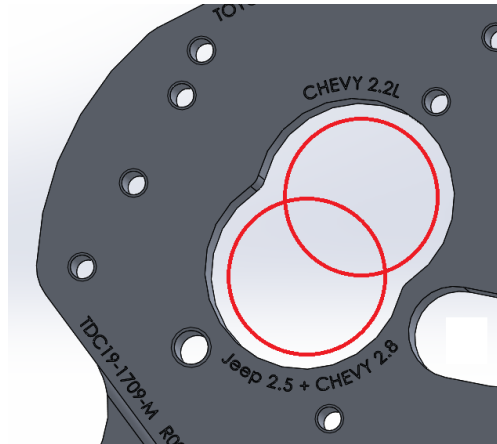

2. You may need to drill clearance holes into bellhousing for the 5/16" starter motor bolts. These will be clearance holes and do not need to be threaded.
3. Remove the factory dowels from the bellhousing. Our transmission adapter plate will have the dowels pre-installed for you.

Installation Manual Special Note:

The products supplied in this kit are manufactured and assembled specifically for this conversion type. The hardware supplied may have more or less bolts than required for your specific application. Modification to components will void any possible warranty or returns. This information is provided as a guide to aid with installation process, it is by no means "complete and exact". We recommend using your vehicle specific Factory Service Manual for additional information.

Starter Motor Notes (Toyota 4.7 starter)

- The mounting positions shown below are for Toyota 4.7 starter motor compatible adapter kits.
- This transmission plate can be used with any Jeep 2.5L transmission. This plate is compatible with three different engines (Jeep 2.5, Chevy 2.8, an chevy 2.2). Choose starter position that corresponds with your transmission type.
- The starter motor can be rotated to multiple clocking positions.
- The Toyota 4.7 starter motor requires a 12 pitch pinion gear, the OEM 10 pitch pinion cannot be used with this kit.

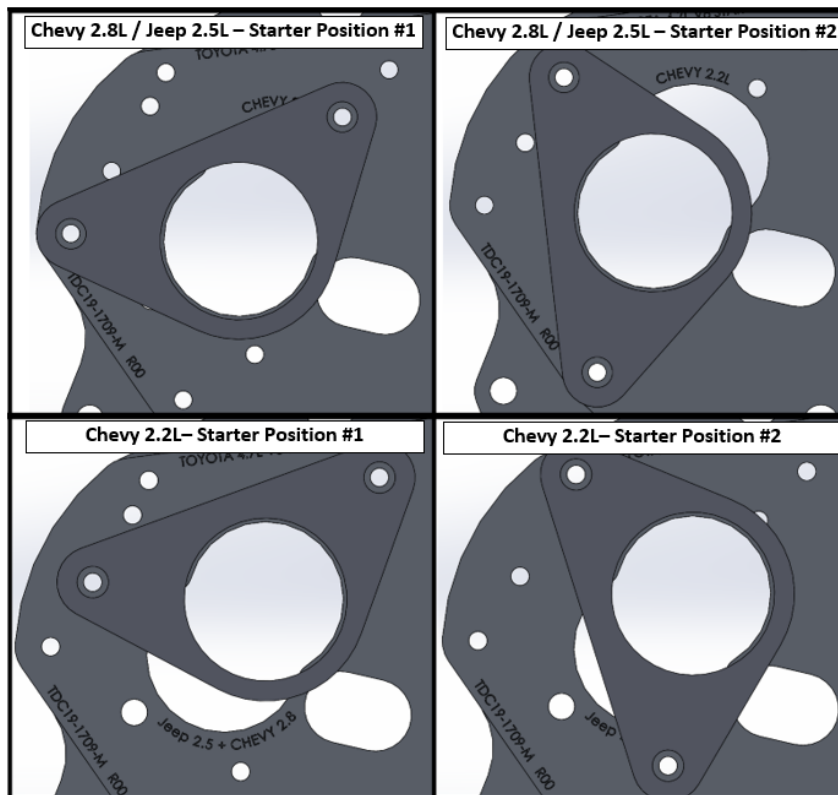
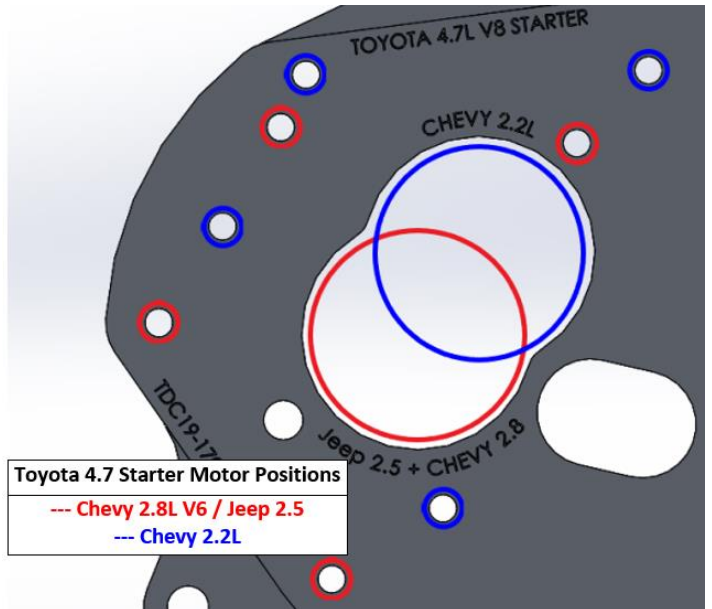

Installation Manual Special Note:

The products supplied in this kit are manufactured and assembled specifically for this conversion type. The hardware supplied may have more or less bolts than required for your specific application. Modification to components will void any possible warranty or returns. This information is provided as a guide to aid with installation process, it is by no means “complete and exact”. We recommend using your vehicle specific Factory Service Manual for additional information.

Nissan 2.4L Adapter Kits

Transmission Bellhousing Hardware

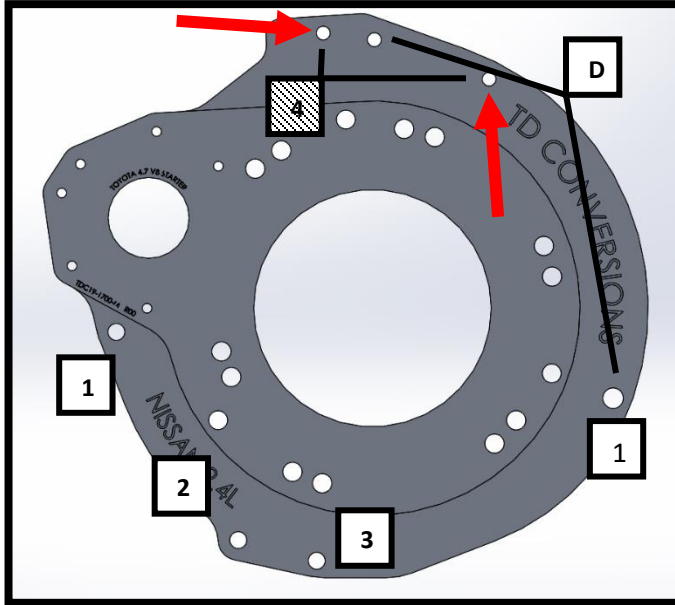

Nissan 2.4L Hardware			
Bolt #	Bolt Size	Type of Mounting	Torque Spec.
1	7/16" x 2-3/4" NC CS	Thru	35 ft-lbs
2	3/8" x 1-1/2" NC CS	Thru	31 ft-lbs
3	3/8" x 2" NC CS	Thru	31 ft-lbs
4	7/16" x 2-1/2" NC CS	Threaded	35 ft-lbs
D	Dowel		

Bolt Orientation

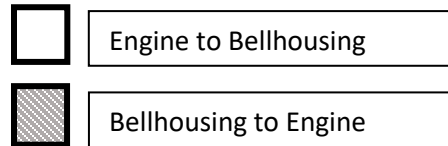

Bellhousing Modification

1. Remove material from the circled area for starter motor clearance, see photo below.

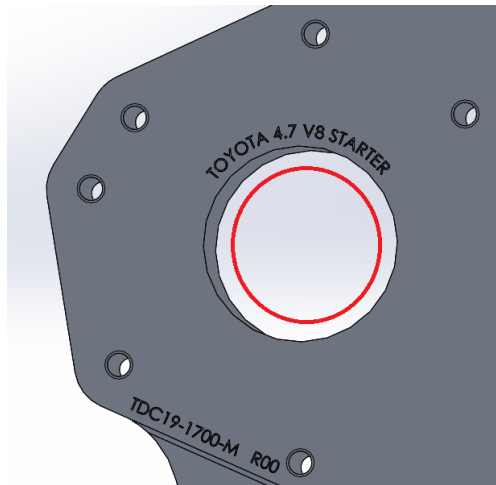

2. You may need to drill clearance holes into bellhousing for the 5/16" starter motor bolts. These will be clearance holes and do not need to be threaded.
3. The bell housing requires enlarging two holes to clear the 7/16" bolts. Use a 1/2" drill to enlarge the two holes pointed out by red arrows above.

Installation Manual Special Note:

The products supplied in this kit are manufactured and assembled specifically for this conversion type. The hardware supplied may have more or less bolts than required for your specific application. Modification to components will void any possible warranty or returns. This information is provided as a guide to aid with installation process, it is by no means "complete and exact". We recommend using your vehicle specific Factory Service Manual for additional information.

Starter Motor Notes (Toyota 4.7 starter)

- The mounting positions shown below are for Toyota 4.7 starter motor compatible adapter kits.
- This transmission plate can be used with any Nissan 2.4L (KA24DE) transmission.
- The starter motor can be rotated to multiple clocking positions.
- This kit utilizes a 10-pitch starter motor pinion gear. You do not need to swap to the 12-pitch.

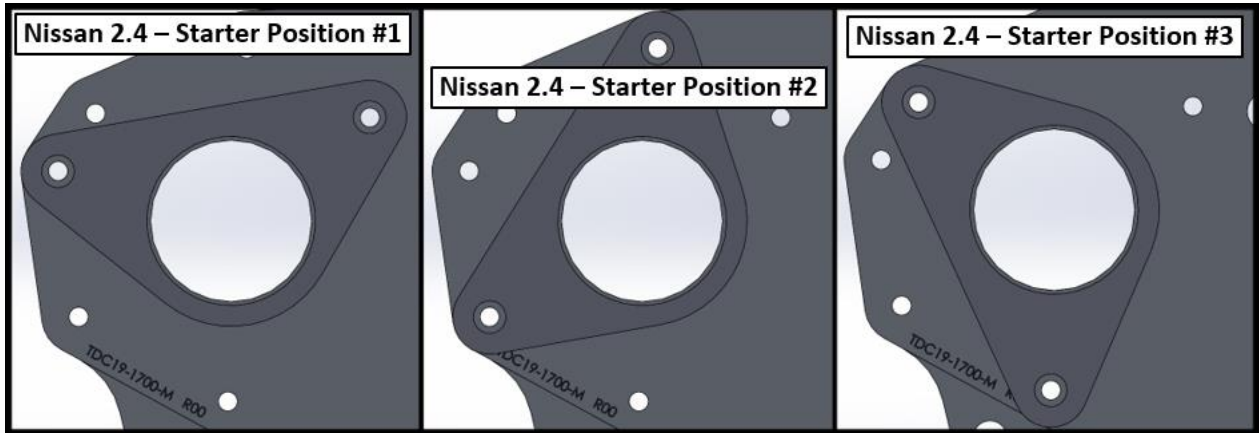

Installation Manual Special Note:

The products supplied in this kit are manufactured and assembled specifically for this conversion type. The hardware supplied may have more or less bolts than required for your specific application. Modification to components will void any possible warranty or returns. This information is provided as a guide to aid with installation process, it is by no means "complete and exact". We recommend using your vehicle specific Factory Service Manual for additional information.

Nissan 3.0L/3.3L Adapter Kits

Transmission Bellhousing Hardware

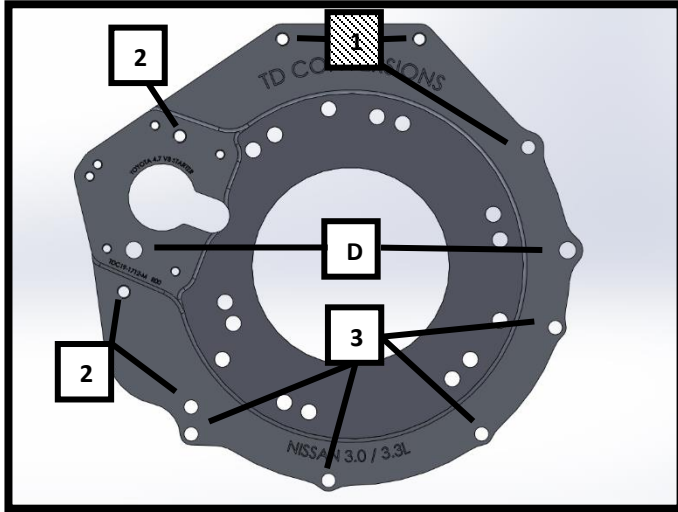

Nissan 3 / 3.3L Hardware			
Bolt #	Bolt Size	Type of Mounting	Torque Spec.
1	7/16" x 1-3/4" NC CS	Threaded	35 ft-lbs
2	7/16" x 2" NC CS	Threaded	35 ft-lbs
3	M10 x 1.5 x 30mm CS	Threaded	38 ft-lbs
D	Dowel		

Bolt Orientation

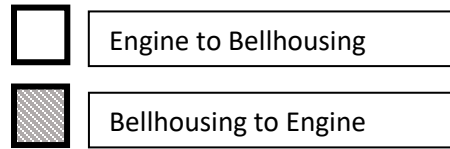

Bellhousing Modification

1. Remove material from the circled area for starter motor clearance, see photo below.

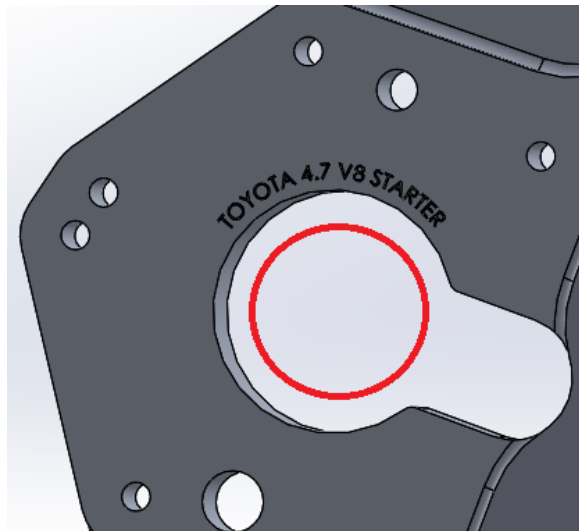

2. You may need to drill clearance holes into bellhousing for the 5/16" starter motor bolts. These will be clearance holes and do not need to be threaded.
3. Remove the factory dowels from the bellhousing. Our transmission adapter plate will have the dowels pre-installed for you.

Installation Manual Special Note:

The products supplied in this kit are manufactured and assembled specifically for this conversion type. The hardware supplied may have more or less bolts than required for your specific application. Modification to components will void any possible warranty or returns. This information is provided as a guide to aid with installation process, it is by no means "complete and exact". We recommend using your vehicle specific Factory Service Manual for additional information.

Starter Motor Notes (Toyota 4.7 starter)

- The mounting positions shown below are for Toyota 4.7 starter motor compatible adapter kits.
- This transmission plate can be used with any Nissan 3.0/3.3 (VG30/VG33) transmission.
- The starter motor can be rotated to multiple clocking positions.
- This kit utilizes a 10-pitch starter motor pinion gear. You do not need to swap to the 12-pitch.

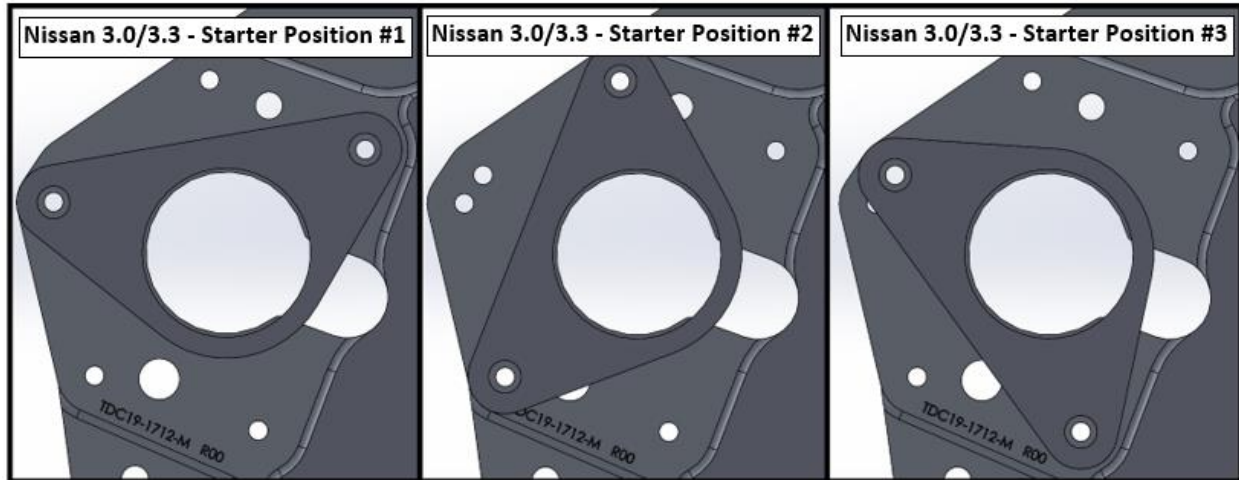

Installation Manual Special Note:

The products supplied in this kit are manufactured and assembled specifically for this conversion type. The hardware supplied may have more or less bolts than required for your specific application. Modification to components will void any possible warranty or returns. This information is provided as a guide to aid with installation process, it is by no means “complete and exact”. We recommend using your vehicle specific Factory Service Manual for additional information.

Toyota 4.0L Adapter Kits

Transmission Bellhousing Hardware

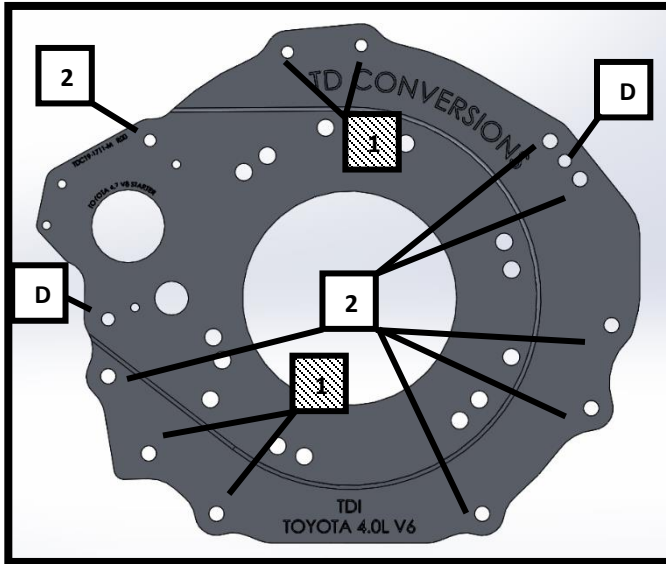

Toyota 4.0L Hardware			
Bolt #	Bolt Size	Type of Mounting	Torque Spec.
1	7/16" x 1-3/4" NC CS	Threaded	35 ft-lb
2	7/16" x 2-1/4" NC CS	Thru	49 ft-lb
3	7/16" x 2" NC CS	Threaded	35 ft-lb
D	Dowel		

Bolt Orientation

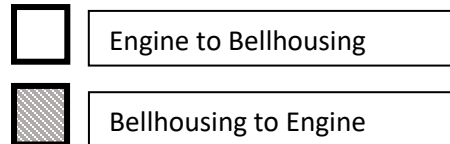

Bellhousing Modification

1. Remove material from the circled area for starter motor clearance, see photo below.

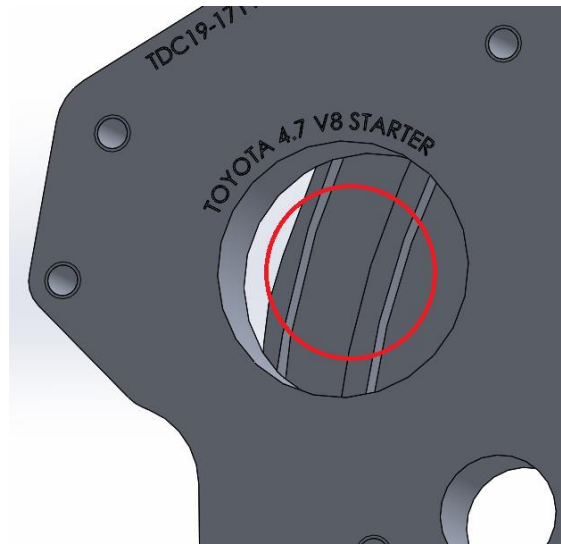

2. You may need to drill clearance holes into bellhousing for the 5/16" starter motor bolts. These will be clearance holes and do not need to be threaded.
3. Remove the factory dowels from the bellhousing. Our transmission adapter plate will have the dowels pre-installed for you.

Installation Manual Special Note:

The products supplied in this kit are manufactured and assembled specifically for this conversion type. The hardware supplied may have more or less bolts than required for your specific application. Modification to components will void any possible warranty or returns. This information is provided as a guide to aid with installation process, it is by no means "complete and exact". We recommend using your vehicle specific Factory Service Manual for additional information.

Starter Motor Notes (Toyota 4.7 starter)

- The mounting positions shown below are for Toyota 4.7 starter motor compatible adapter kits.
- This transmission plate can be used with any Toyota 4.0L transmission.
- The starter motor can be rotated to multiple clocking positions.
- This kit utilizes a 10-pitch starter motor pinion gear. You do not need to swap to the 12-pitch.

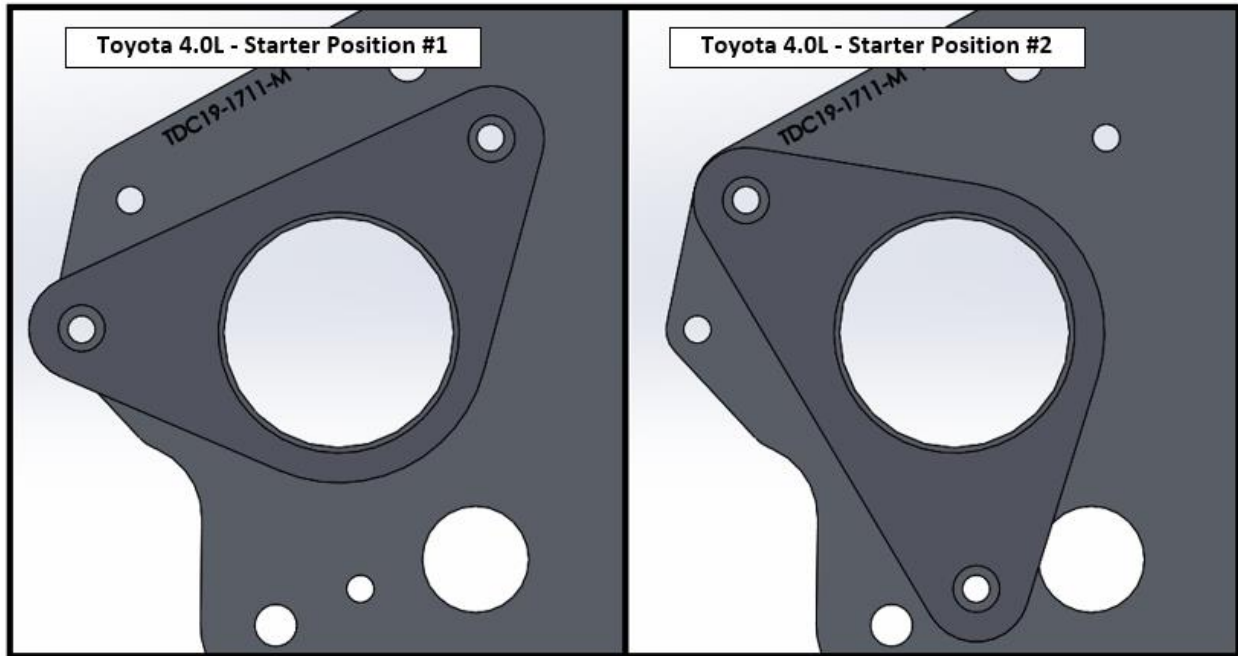

Installation Manual Special Note:

The products supplied in this kit are manufactured and assembled specifically for this conversion type. The hardware supplied may have more or less bolts than required for your specific application. Modification to components will void any possible warranty or returns. This information is provided as a guide to aid with installation process, it is by no means "complete and exact". We recommend using your vehicle specific Factory Service Manual for additional information.

Toyota 3.0/3.4L Adapter Kits

Transmission Bellhousing Hardware

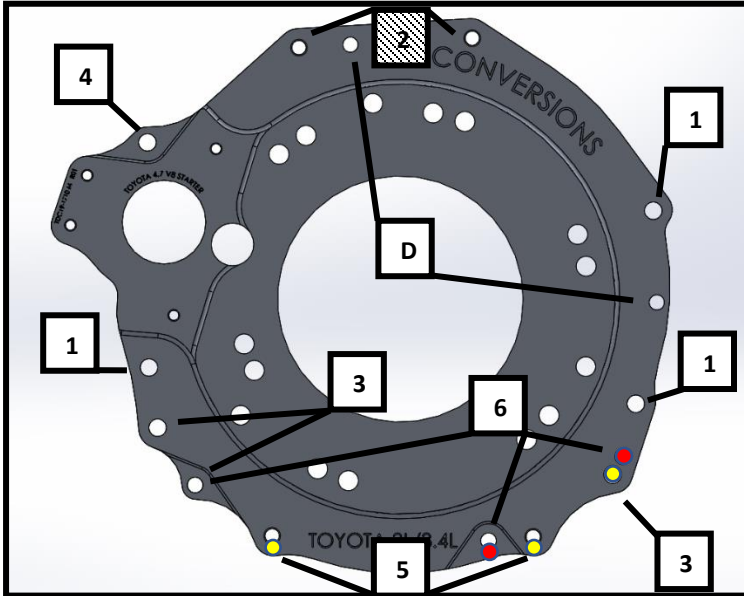

Toyota 3.0/3.4L Hardware			
Bolt #	Bolt Size	Type of Mounting	Torque Spec.
1	7/16" x 3" NC CS	Thru	49 ft-lb
2	7/16" x 2-3/4" NC CS	Threaded	35 ft-lb
3	7/16" x 2" NC CS	Thru	49 ft-lb
4	7/16" x 1-3/4" NC CS	Thru	49 ft-lb
5	7/16" x 1-1/2" NC CS	Threaded	35 ft-lb
6	M8 x 1.25 x 30mm	Thru	18 ft-lb
D	Dowel		

Toyota 3.0/3.4L Bolt Specifics

- Toyota 3.0L only
- Toyota 3.4L only

Bolt Orientation

- Engine to Bellhousing
- Bellhousing to Engine

Bellhousing Modification

1. You may need to drill clearance holes into bellhousing for the 5/16" starter motor bolts. These will be clearance holes and do not need to be threaded.
2. Remove the factory dowels from the bellhousing. Our transmission adapter plate will have the dowels pre-installed for you.

Installation Manual Special Note:

The products supplied in this kit are manufactured and assembled specifically for this conversion type. The hardware supplied may have more or less bolts than required for your specific application. Modification to components will void any possible warranty or returns. This information is provided as a guide to aid with installation process, it is by no means "complete and exact". We recommend using your vehicle specific Factory Service Manual for additional information.

Starter Motor Notes (Toyota 4.7 starter)

- The mounting positions shown below are for Toyota 4.7 starter motor compatible adapter kits.
- This transmission plate can be used with any Toyota 3.0/3.4L transmission.
- The starter motor can be rotated to multiple clocking positions.
- This kit utilizes a 10-pitch starter motor pinion gear. You do not need to swap to the 12-pitch.

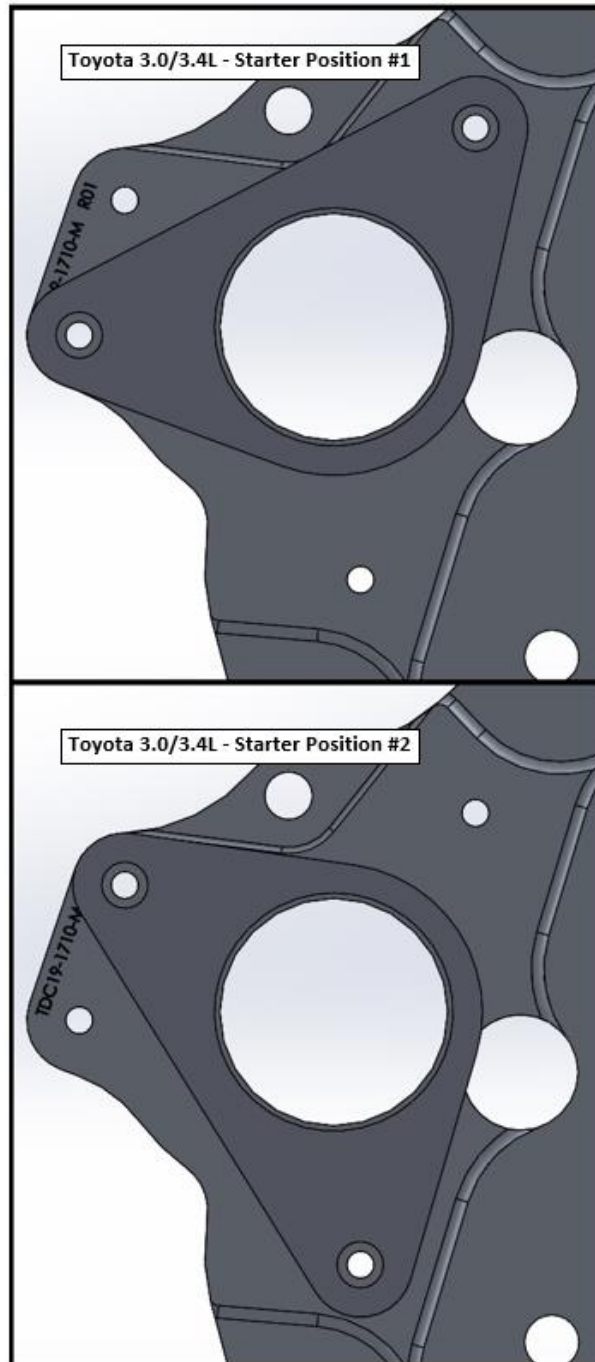

Installation Manual Special Note:

The products supplied in this kit are manufactured and assembled specifically for this conversion type. The hardware supplied may have more or less bolts than required for your specific application. Modification to components will void any possible warranty or returns. This information is provided as a guide to aid with installation process, it is by no means "complete and exact". We recommend using your vehicle specific Factory Service Manual for additional information.

Toyota 2.7L Adapter Kits

Transmission Bellhousing Hardware

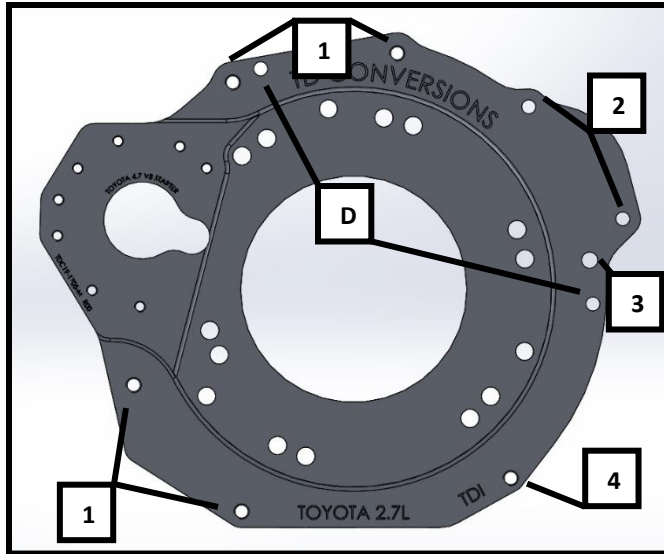

Toyota 2.7L Hardware			
Bolt #	Bolt Size	Type of Mounting	Torque Spec.
1	7/16" x 2-1/4" NC CS	Threaded	35 ft-lbs
2	3/8" x 2-1/2" NC CS	Thru	31 ft-lbs
3	7/16" x 2" NC CS	Thru	49 ft-lbs
4	7/16" x 1-1/2" NC CS	Threaded	35 ft-lbs
D	Dowel		

Bolt Orientation

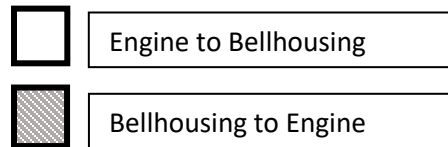

Bellhousing Modification

1. Remove material from the circled area for starter motor clearance, see photo below.
2. You may need to drill clearance holes into bellhousing for the 5/16" starter motor bolts. These will be clearance holes and do not need to be threaded.
3. Remove the factory dowels from the bellhousing. Our transmission adapter plate will have the dowels pre-installed for you.

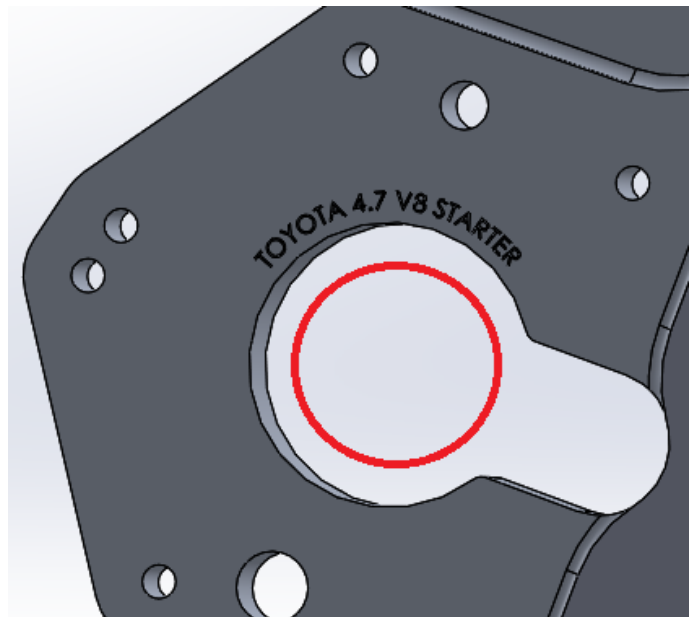

Installation Manual Special Note:

The products supplied in this kit are manufactured and assembled specifically for this conversion type. The hardware supplied may have more or less bolts than required for your specific application. Modification to components will void any possible warranty or returns. This information is provided as a guide to aid with installation process, it is by no means "complete and exact". We recommend using your vehicle specific Factory Service Manual for additional information.

Starter Motor Notes (Toyota 4.7 starter)

- The mounting positions shown below are for Toyota 4.7 starter motor compatible adapter kits.
- This transmission plate can be used with any Toyota 3.0/3.4L transmission.
- The starter motor can be rotated to multiple clocking positions.
- This kit utilizes a 10-pitch starter motor pinion gear. You do not need to swap to the 12-pitch.

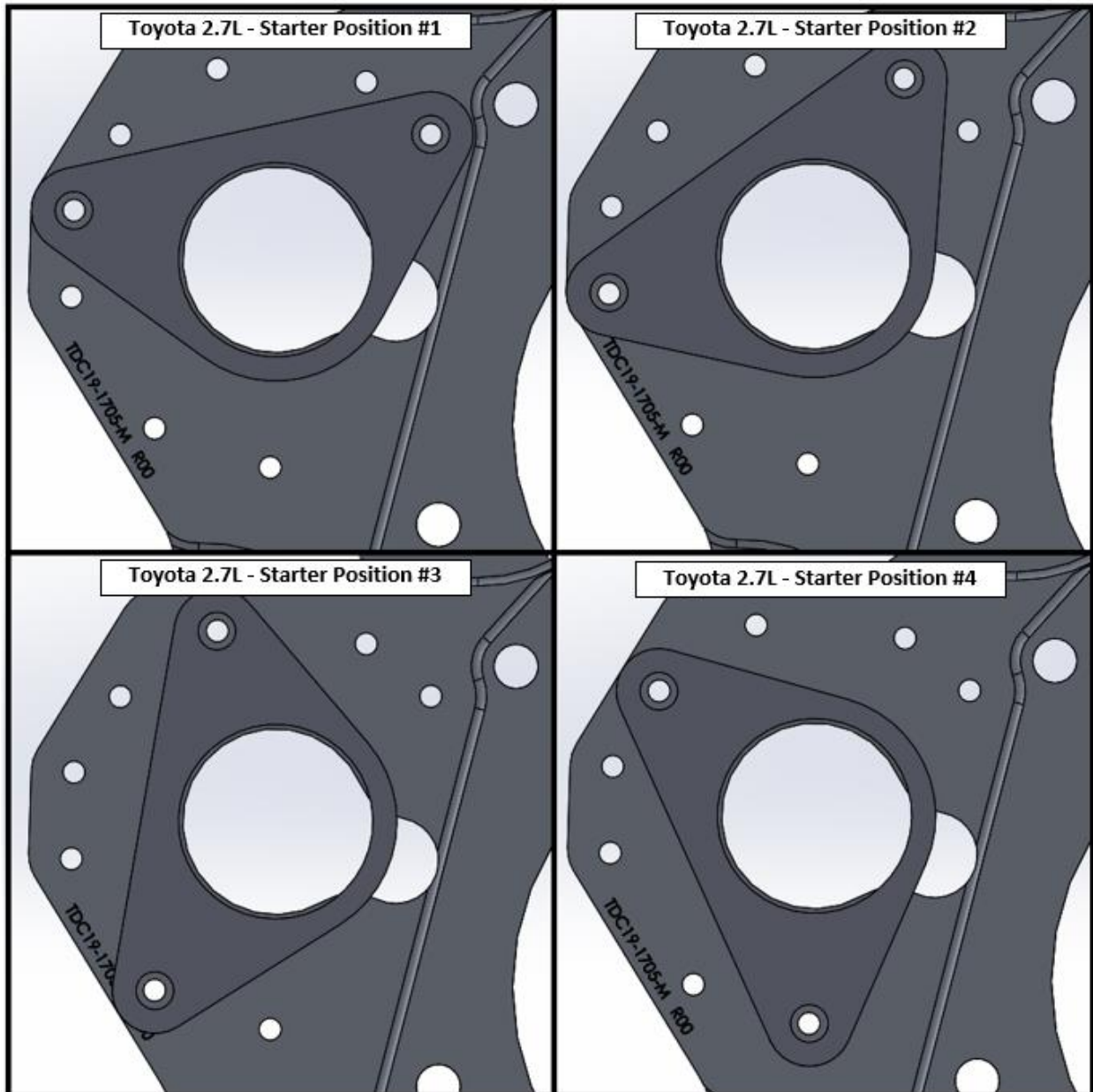

Installation Manual Special Note:

The products supplied in this kit are manufactured and assembled specifically for this conversion type. The hardware supplied may have more or less bolts than required for your specific application. Modification to components will void any possible warranty or returns. This information is provided as a guide to aid with installation process, it is by no means "complete and exact". We recommend using your vehicle specific Factory Service Manual for additional information.

Toyota 22R Adapter Kits

Transmission Bellhousing Hardware

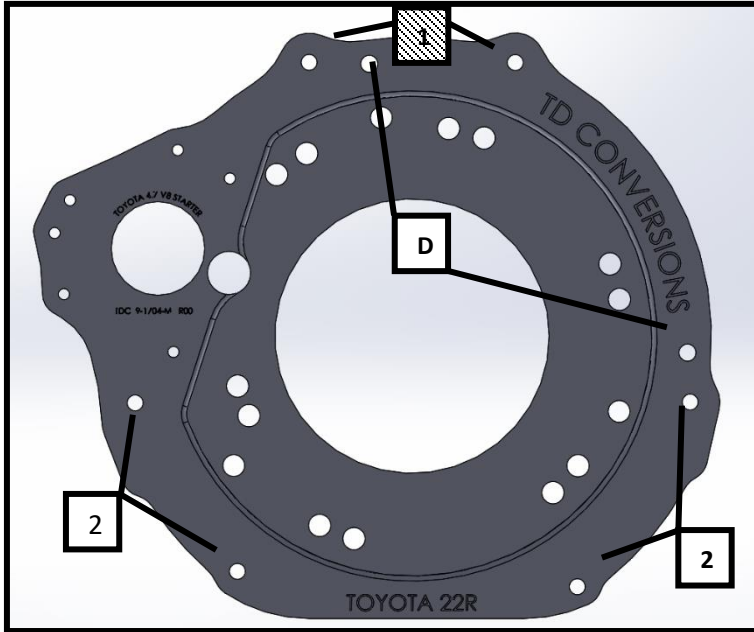

Toyota 22R Hardware			
Bolt #	Bolt Size	Type of Mounting	Torque Spec.
1	7/16" x 1-3/4" NC CS	Threaded	35 ft-lb
2	7/16" x 1-1/2" NC CS	Thru	49 ft-lb
3	Dowel	N/A	N/A

Bolt Orientation

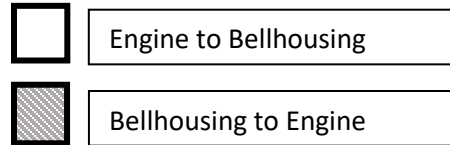

Bellhousing Modification

1. You may need to drill clearance holes into bellhousing for the 5/16" starter motor bolts. These will be clearance holes and do not need to be threaded.
2. Remove the factory dowels from the bellhousing. Our transmission adapter plate will have the dowels pre-installed for you.

Installation Manual Special Note:

The products supplied in this kit are manufactured and assembled specifically for this conversion type. The hardware supplied may have more or less bolts than required for your specific application. Modification to components will void any possible warranty or returns. This information is provided as a guide to aid with installation process, it is by no means "complete and exact". We recommend using your vehicle specific Factory Service Manual for additional information.

Starter Motor Notes (Toyota 4.7 starter)

- The mounting positions shown below are for Toyota 4.7 starter motor compatible adapter kits.
- This transmission plate can be used with any Toyota 3.0/3.4L transmission.
- The starter motor can be rotated to multiple clocking positions.
- This kit utilizes a 10-pitch starter motor pinion gear. You do not need to swap to the 12-pitch.

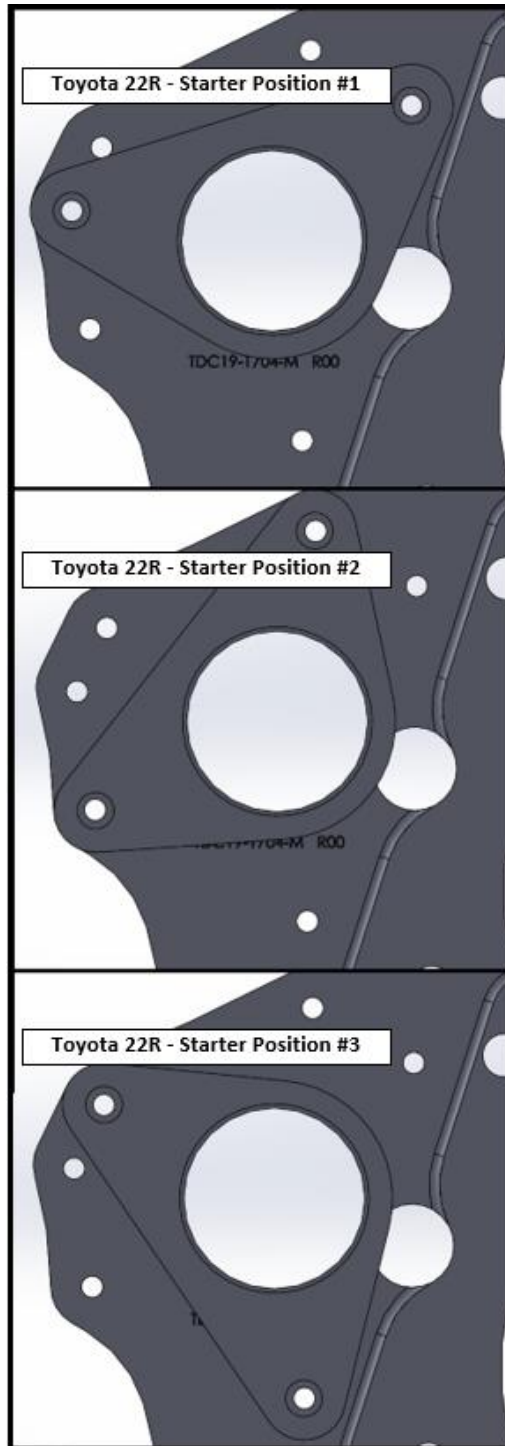

Installation Manual Special Note:

The products supplied in this kit are manufactured and assembled specifically for this conversion type. The hardware supplied may have more or less bolts than required for your specific application. Modification to components will void any possible warranty or returns. This information is provided as a guide to aid with installation process, it is by no means “complete and exact”. We recommend using your vehicle specific Factory Service Manual for additional information.

Your TD Conversions kit should now be assembled and look like the image below.

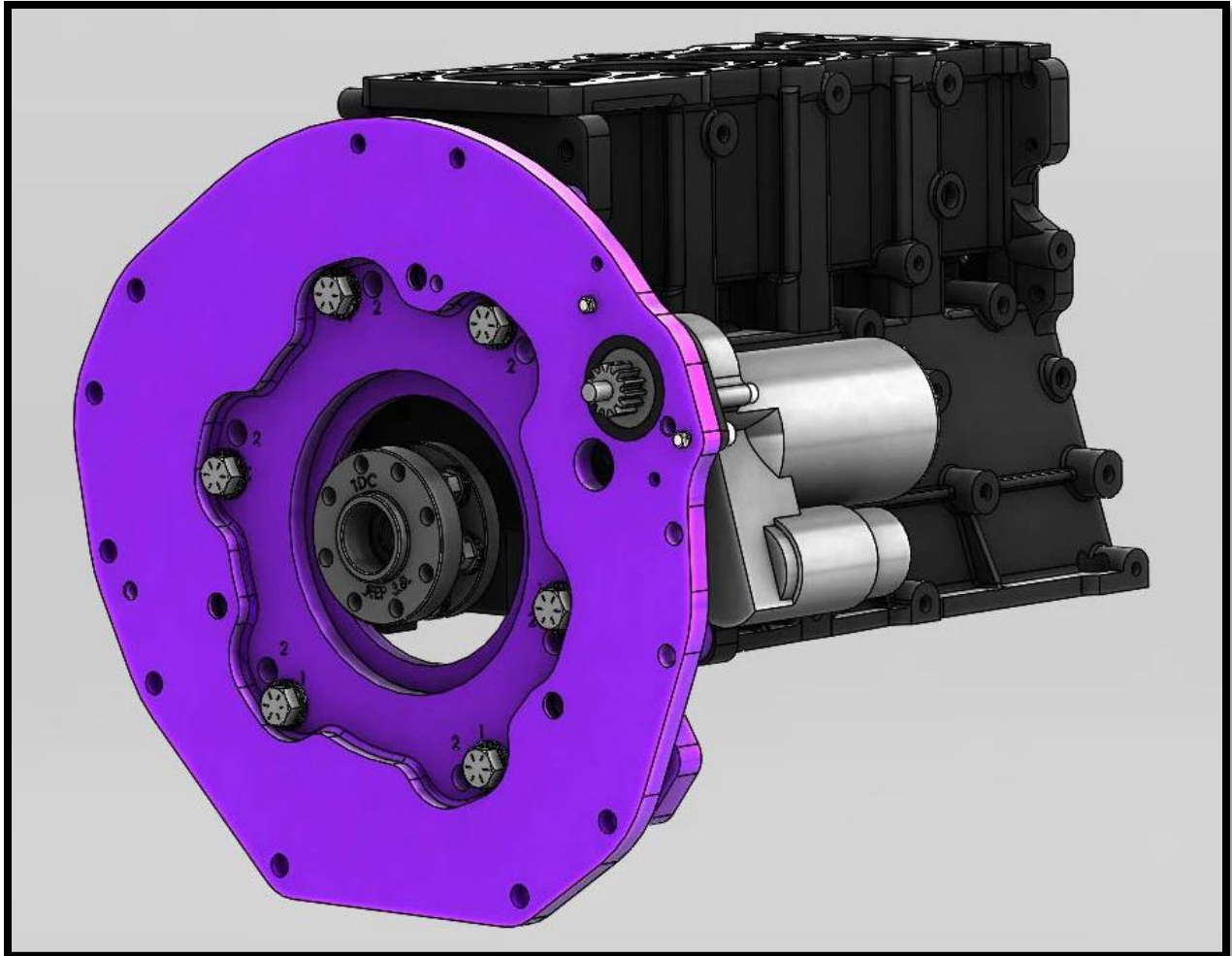

Thank you for choosing TD Conversions!

For additional information, email us: info@tdconversions.com

Installation Manual Special Note:

The products supplied in this kit are manufactured and assembled specifically for this conversion type. The hardware supplied may have more or less bolts than required for your specific application. Modification to components will void any possible warranty or returns. This information is provided as a guide to aid with installation process, it is by no means “complete and exact”. We recommend using your vehicle specific Factory Service Manual for additional information.