

Ma*i*[®]
CLIMBER
» XL
FULL-BODY WORKOUT

AS SEEN ON
TV



**ASSEMBLY
MANUAL**

SAFETY INSTRUCTIONS

¡IMPORTANT!

READ THIS MANUAL CAREFULLY BEFORE USING THIS PRODUCT. THE MANUFACTURER ASSUMES NO RESPONSIBILITY FOR DAMAGE OR INJURY TO THE USER OR PROPERTY BY THE USE OF THIS EQUIPMENT.

SAFETY INSTRUCTIONS AND MAINTENANCE

- The owner of the equipment is responsible to ensure that all users of it are informed of safety measures and proper use.
- Use the equipment only as described in this manual.
- Place the product on a flat, stable surface, with at least 2 meters of clearance around it. It is recommended to place a blanket under the equipment to protect the floor or carpet from any damage.
- Keep the assembling area clean and well lit. Untidy and dark areas can lead to accidents.
- Keep the equipment indoors, away from moisture and dust. Do not place it in the garage, cottage, shed, conservatory, patio, garden, etc. or near water or liquids. Ignoring this instruction may cause serious safety and electrical problems.
- Do not operate the equipment where aerosol products are being used or oxygen is being provided.
- Keep children under 12 years old and pets away from the equipment at all times. Do not leave children unattended in the same room with the equipment.
- People with disabilities should not use the equipment without supervision of qualified personnel.
- People with malignant tumors, preexisting conditions, under treatment, heart disease or any electronic device implanted in the body, should consult their doctor before using the equipment.
- This equipment should not be used by pregnant women.
- Never allow more than one person at a time using the equipment.
- Do not use the equipment if you feel tiredness or under the effect of narcotics, drugs or alcohol.
- Do not use the equipment if indoors temperature is over 40°C.
- Always wear appropriate workout clothing when exercising. Do not wear loose clothing, jewelry or accessories that could be caught in the mechanical parts. It is recommended to wear gym clothes for both men and women.
- If the user feels dizziness, nausea, chest pain or any other abnormal symptoms, he should stop exercising and consult a physician immediately.
- This equipment is only for domestic use. Do not use it for commercial purposes.
- Never use abrasives or solvents to clean the equipment. To prevent damage to the computer, keep liquids away from it and avoid direct sunlight as well.
- After each workout wipe the computer and other surfaces with a soft cloth dampened with water or a dried one, to remove the perspiration on it.
- Check and adjust every part regularly. Replace any damaged part immediately.
- If it is necessary, contact any authorized technical service. The equipment should be serviced by a qualified specialist using only standard spare parts.
- Be careful when using or moving the equipment in order to avoid physical injuries.
- Proper maintenance of the product is very important to ensure optimal operation. Improper maintenance or lack thereof, can damage the equipment life.
- Do not modify its incline by placing objects underneath.

Keep this user manual in a safety place for future reference.

PARTS LIST

N°	DESCRIPTION	QTY.
1	Rear stabilizer	1
2	Front stabilizer	1
3	U bracket	1
4	Connecting sheet of rear stabilizer	1
5	Rear base folding tube	1
6	Front base folding tube	1
7	Roller support part	1
8	Front support tube	1
9	Left adjusting tube	1
10	Right adjusting tube	1
11	Upper handlebar	2
12	Left middle handlebar	1
13	Right middle handlebar	1
14	Cellphone support frame	1
15	Aluminum Track	1
16	End cap of rear stabilizer	2
17	Curved washer	4
18	Dome Nut	4
19	Flat washer	22
20	Allen bolt	6
21	Cushions	2
22	End cap for base folding tube	4
23	Flat head inner hexagon bolt	2
24	Nyloc nut	12
25	Knob	3
26	Steel rope	1
27	Left end cap of front stabilizer	1
28	Right end cap of front stabilizer	1
29	Phillips screw	2
30	Left pedal	1
30A	Left pedal strap	1
31	Right pedal	1
31A	Right pedal strap	1
32	Bolt for pulley	8
33	Pulley	8
34	12 level cylinder	2
35	Allen bolt M10	1
36	Flat washer	2
37	Middle cover for pulley	2
38	Bearing 6202	1

PARTS LIST

N°	DESCRIPTION	QTY.
39	Big pulley	1
40	Nyloc nut	1
41	Allen bolt M8	5
42	Allen bolt M8	4
43	Phillips screw	5
44	Square cushion	1
45	Fixed bracket for cylinder	1
46	BushingΦ25	2
47	Allen bolt M8	1
48	Magnet	1
49	Knob	2
50	Bushing	2
51	Square end cap	2
52	Foam grip	2
53	Round end cap	4
54	Retainer ring	8
55	Bearing 608ZZ	8
56	Guiding wheel	4
57	Big cover	1
58	Computer	1
59	Allen bolt M8*40L	2
60	End cap for middle handlebar	2
61	Tearproof Hand grip	2
62	Cross head bolt	1
63	Flat washer	1
64	Bar sensor	1
65	Sensor bracket	1
66	Cross head bolt	5
67	Flat washer	3
68	Ball of cellphone bracket	1
69	Nut of cellphone bracket	1
70	Cellphone clamp	1
71	Flat head inner hexagon bolt	2
72	Carriage bolt	4
73	Bushed bearing	4
74	Allen key	1
75	Wrench	1
76	Plastic roller	2
77	Flat head bolt	2

EXPLODED DIAGRAM

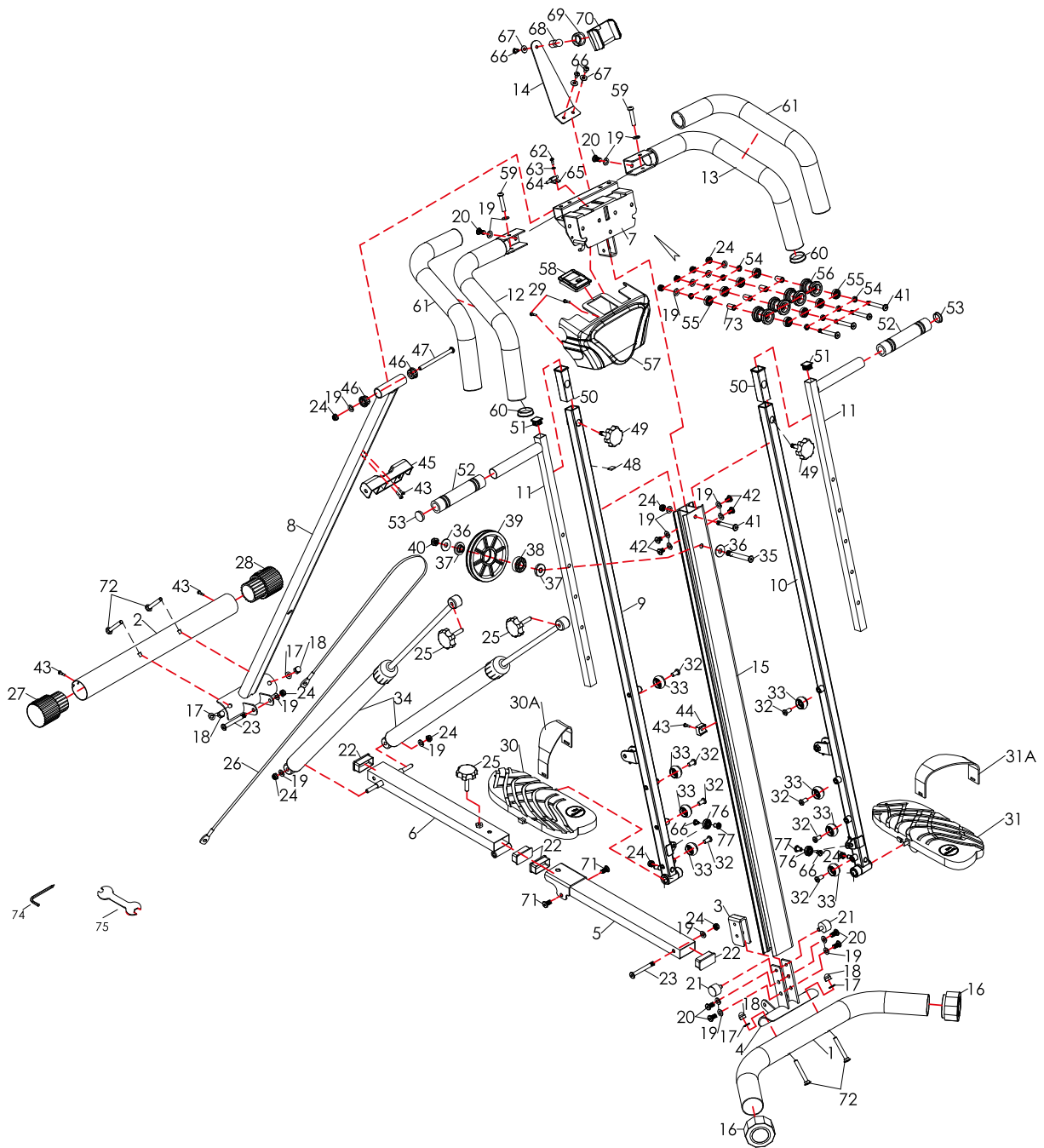

ASSEMBLY DIAGRAM

N°	DESCRIPTION	QTY.	N°	DESCRIPTION	QTY.
1	Rear stabilizer	1	24	Nyloc Nut	1
2	Front stabilizer	1	25	Knob	3
4	Connecting sheet of rear stabilizer	1	30	Left pedal	1
8	Front support tube	1	30A	Left pedal strap	1
9	Left adjusting tube	1	31	Right pedal	1
10	Right adjusting tube	1	31A	Right pedal strap	1
11	Upper handlebar	2	49	Knob	2
12	Left middle handlebar	1	59	Allen bolt M8*40L	2
13	Right middle handlebar	1	66	Cross head bolt	3
14	Cellphone support frame	1	67	Flat washer	3
17	Curved washer	4	70	Cellphone clamp	1
18	Dome Nut	4	72	Carriage bolt	4
19	Flat washer	4	74	Allen key	1
20	Allen bolt	2	75	Wrench	1

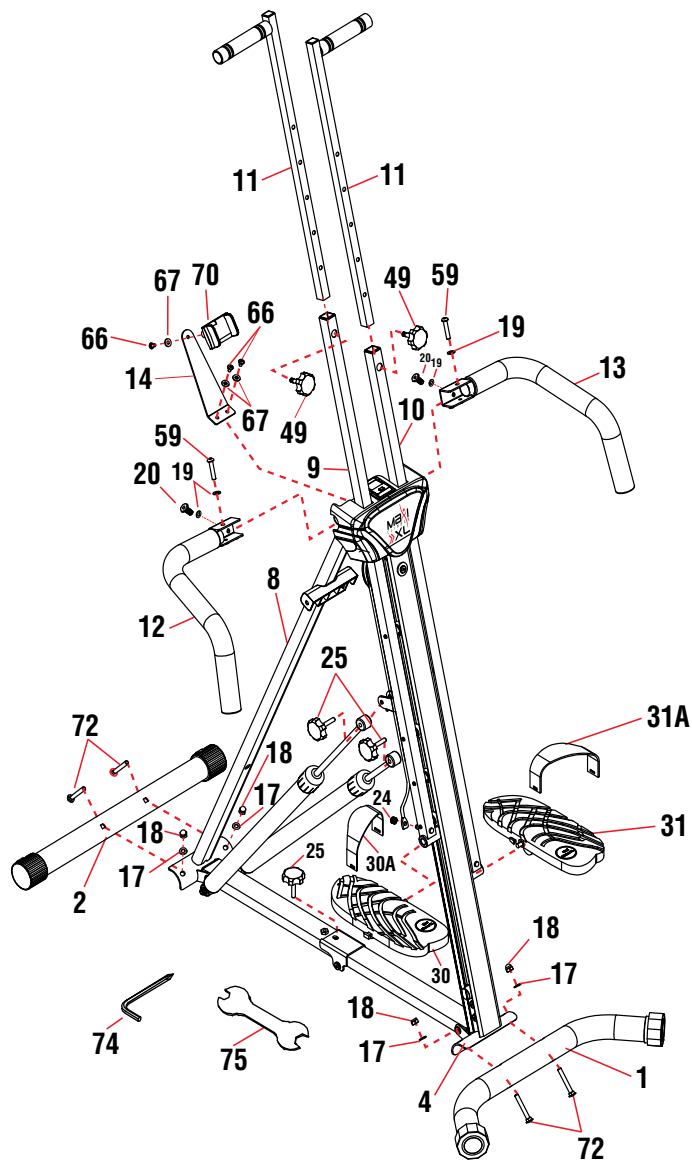

ASSEMBLY INSTRUCTIONS

PREPARATION

- Before the assembly, make sure you have plenty of space around the product.
- Use the tools provided with the product as indicated in this manual.

This product should be used for people whose body weight does not exceed 300lbs (136 kg).

STEP 1

- Remove the knob (25) onto the front support tube (8) by turning it counterclockwise.
- Fully unfold the item. Be careful not to pinch your fingers at the middle of the foldable tubes.
- Insert the knob (25) into middle hole of foldable tubes and turn it clockwise.

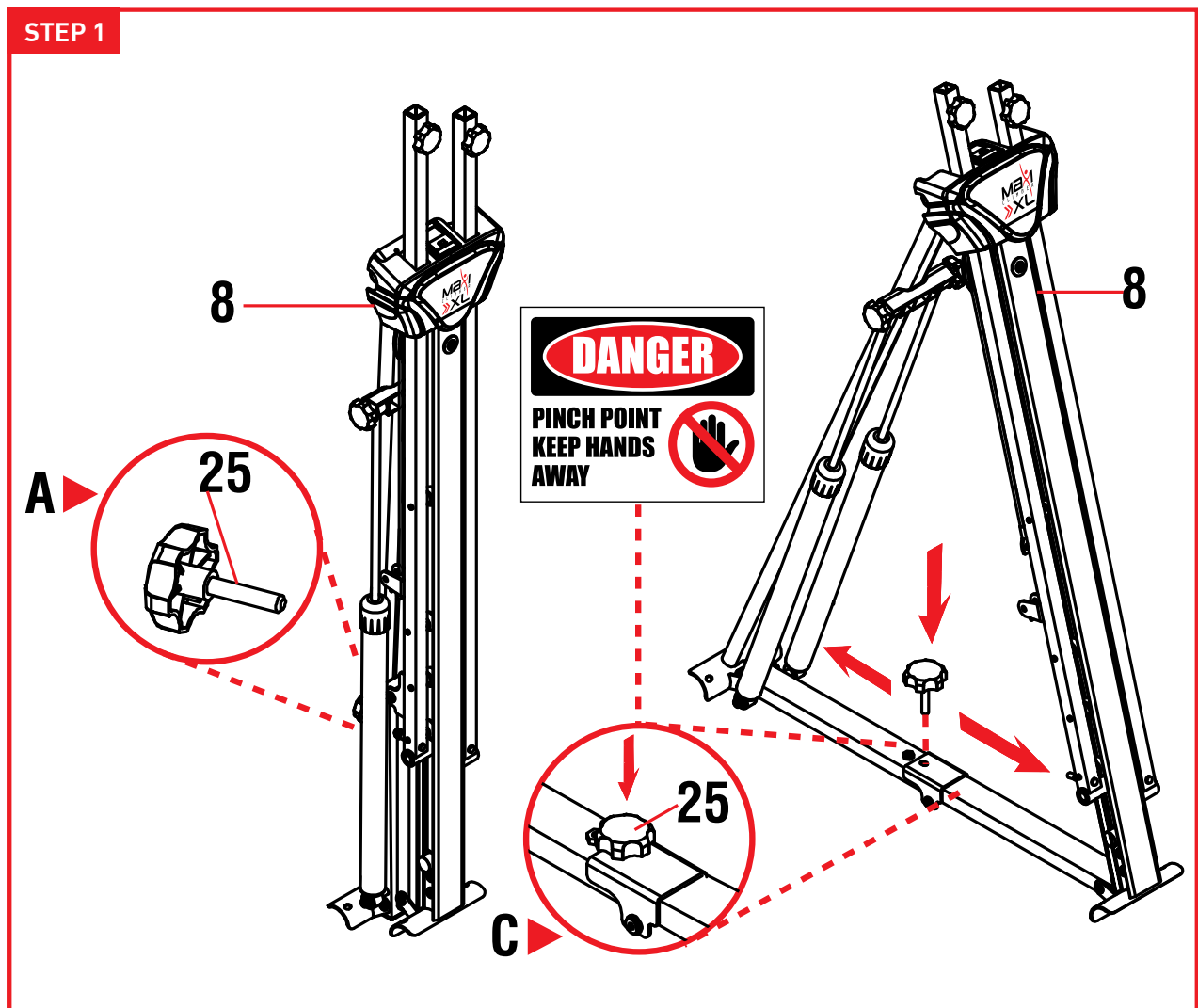

ASSEMBLY INSTRUCTIONS

STEP 2

- A. Remove both knobs (25) at each side of the cylinder bracket (45) by turning them counterclockwise.
- B. Attach the cylinders (34) to the adjustment tubes. Align the holes of the cylinders, insert and tighten knobs (25).
- C. Attach the loose wire (*) passing through position A to the interior welded bolt and tighten it with the nut (24) as shown in the picture. Use the wrench (75) provided.

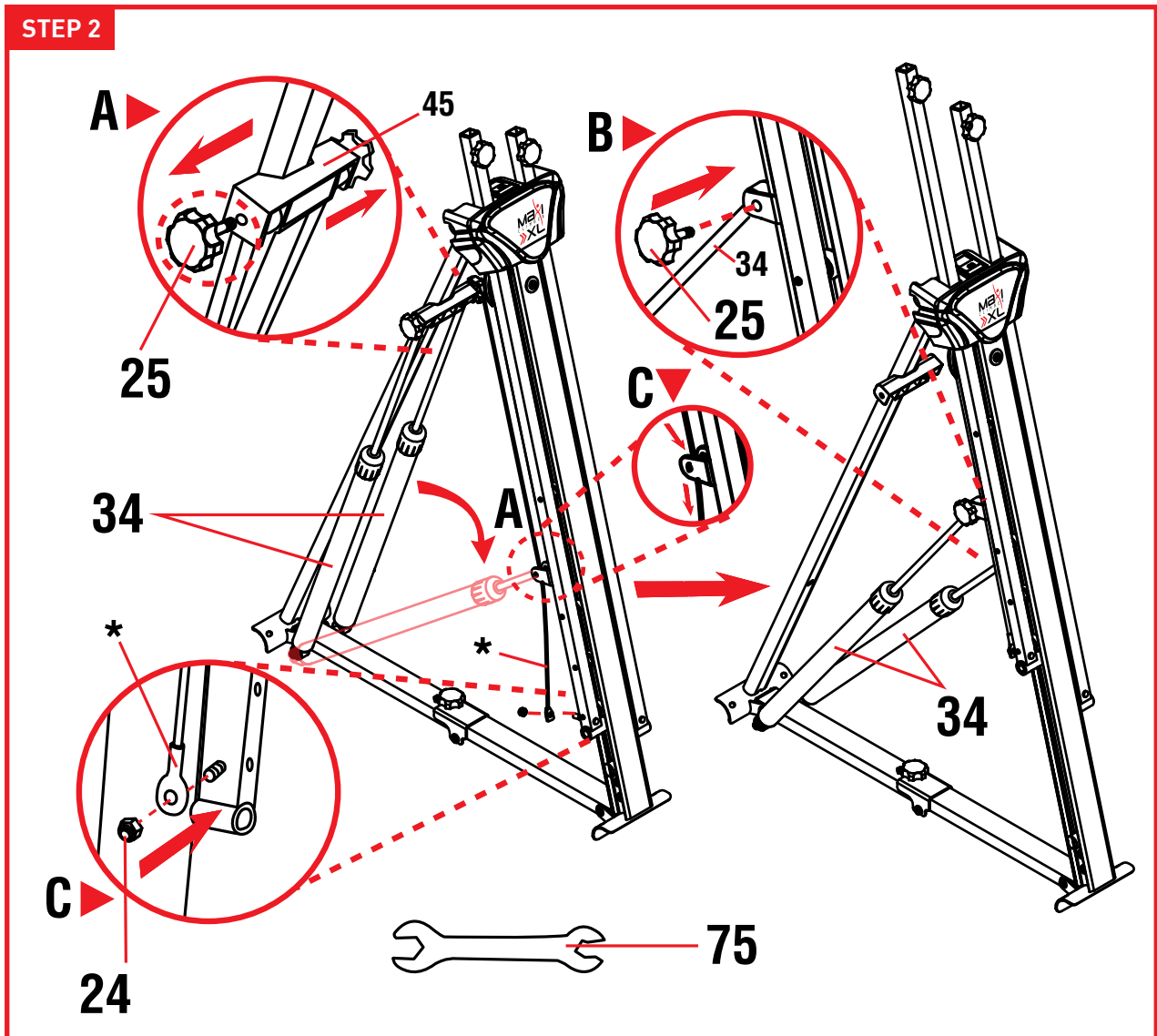

ASSEMBLY INSTRUCTIONS

STEP 3

A. Attach front stabilizer (2) to the base of front support tube (8) and fasten with two large bolts (72) two curved washers (17) and two dome nuts (18). Use the provided wrench (75).

B. Attach rear stabilizer in U (1) to the base of aluminum track (15) and fasten with two large bolts (72) two curved washers (17), and two dome nuts (18). Use the provided wrench (75).

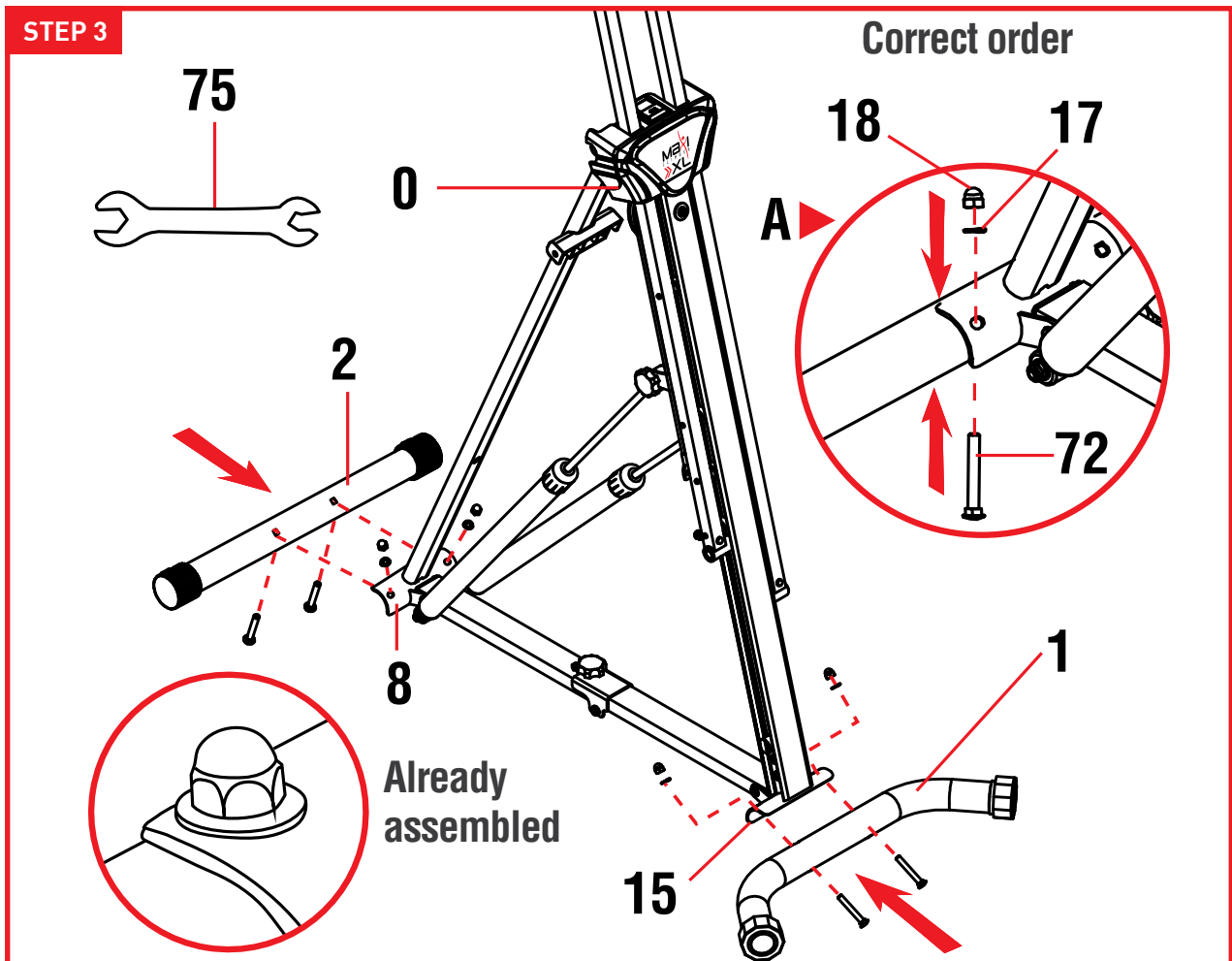

ASSEMBLY INSTRUCTIONS

STEP 4

A. Attach the left pedal strap (30A) onto the left pedal (30L). Make sure that the curved part is aligned with the front part of the pedal.

B. Attach the left pedal (30L) to the left adjusting tube (9) and tighten by turning it clockwise using the wrench provided (75).

C. Repeat the procedure with the right pedal strap (31A) and the right pedal (31R).

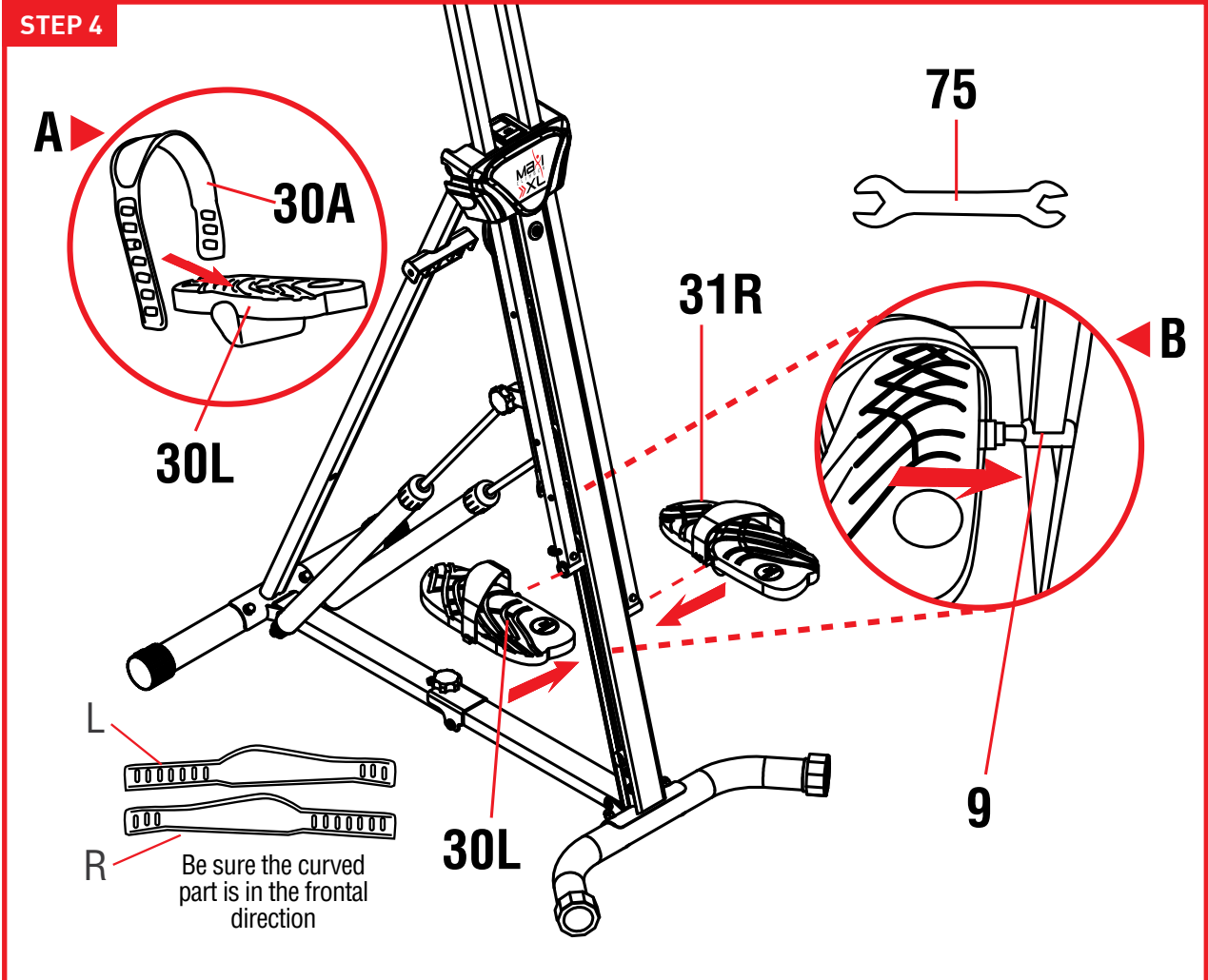

ASSEMBLY INSTRUCTIONS

STEP 5

A. Attach the left middle handlebar (12) to the roller support part (7) and tighten with one washer (19) and one Allen bolt (20) on the front side and one washer (19) and one Allen bolt M8*40L (59) on

the upper side. Bolts and washers are pre-assembled. Use the Allen key provided (74).

B. Repeat this procedure with the right middle handlebar (13).

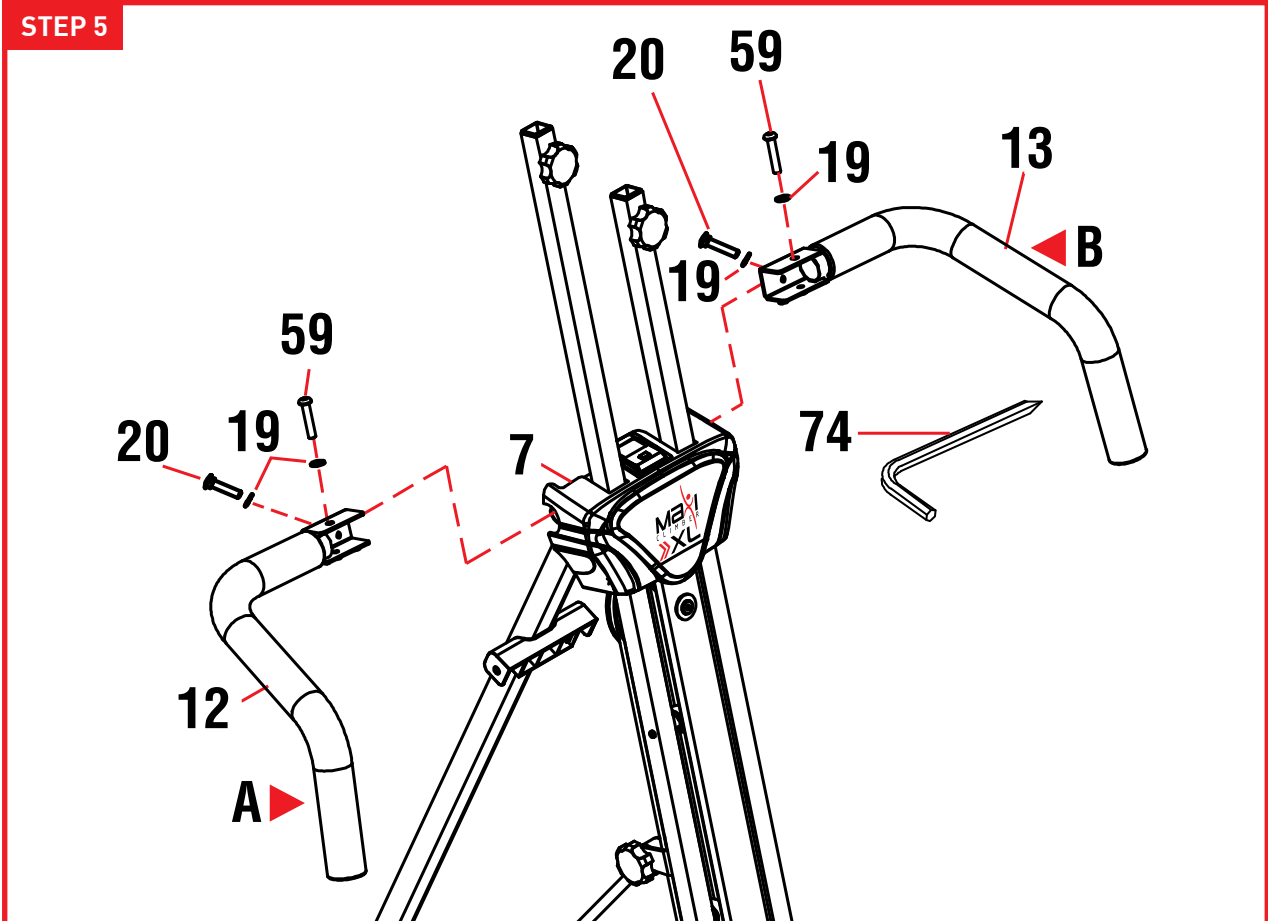

ASSEMBLY INSTRUCTIONS

STEP 6

- A. Release the knob (49) of the right adjusting tube (10) by turning it counterclockwise.
- B. Insert the right upper handlebar (11R) into the right adjusting tube (10) and tighten it with the knob (49) by turning it clockwise to adjust in the desired position.
- C. Repeat the procedure with the left upper handlebar (11L).

STEP 6

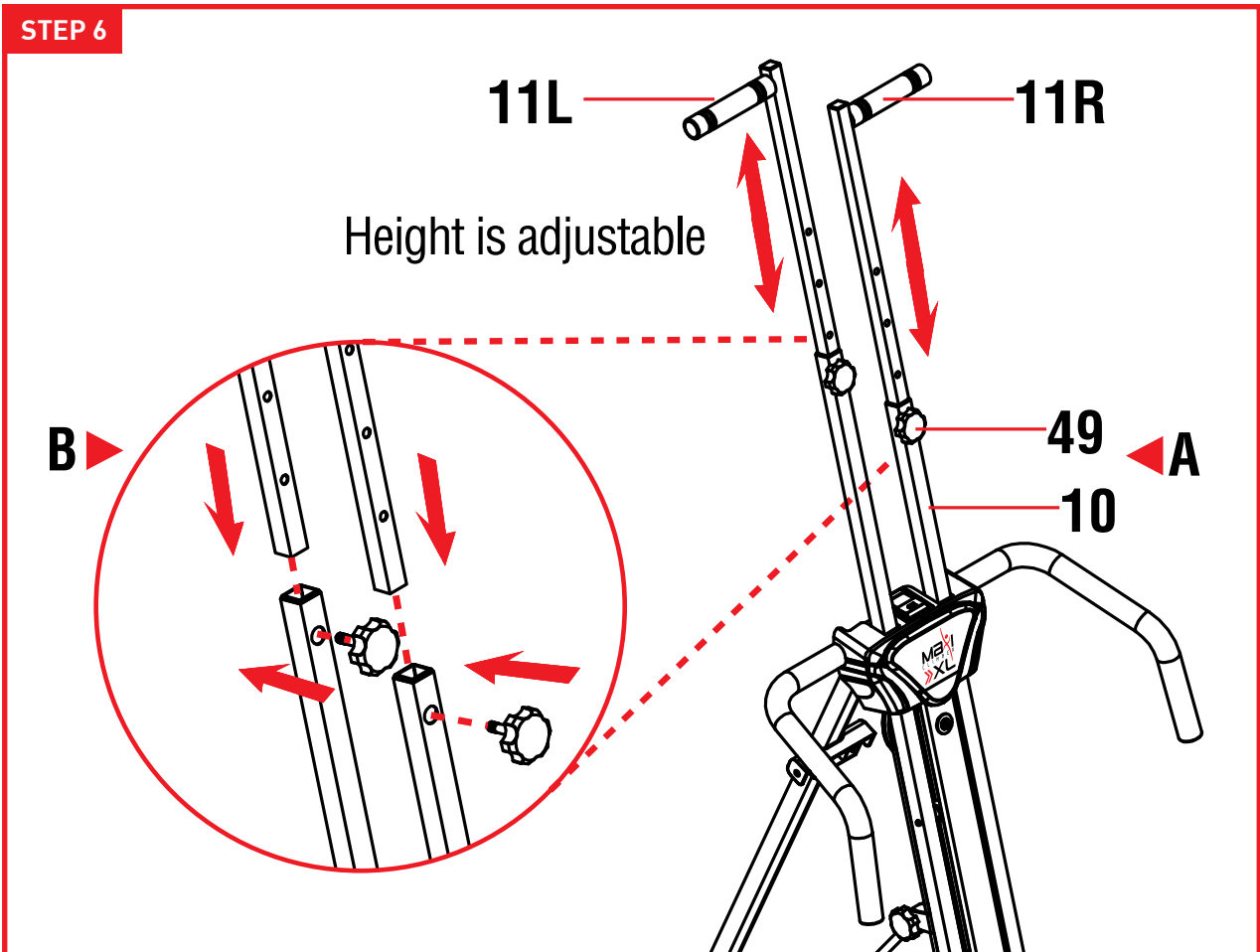

ASSEMBLY INSTRUCTIONS

STEP 7

- A. Attach the cellphone support frame (14) to the roller support part (7) and tighten it with two flat washers (67) and two cross head bolts (66).
- B. Loosen and pull out the preassembled cross head bolt (66) and the flat washer (67) of the cellphone

clamp (70). Attach the cellphone clamp (70) to the cellphone support frame (14) and tighten with the flat washer (67) and the cross head bolt (66). Use the Allen key (74) provided.

Make sure that all pieces are well tightened, before using the equipment.

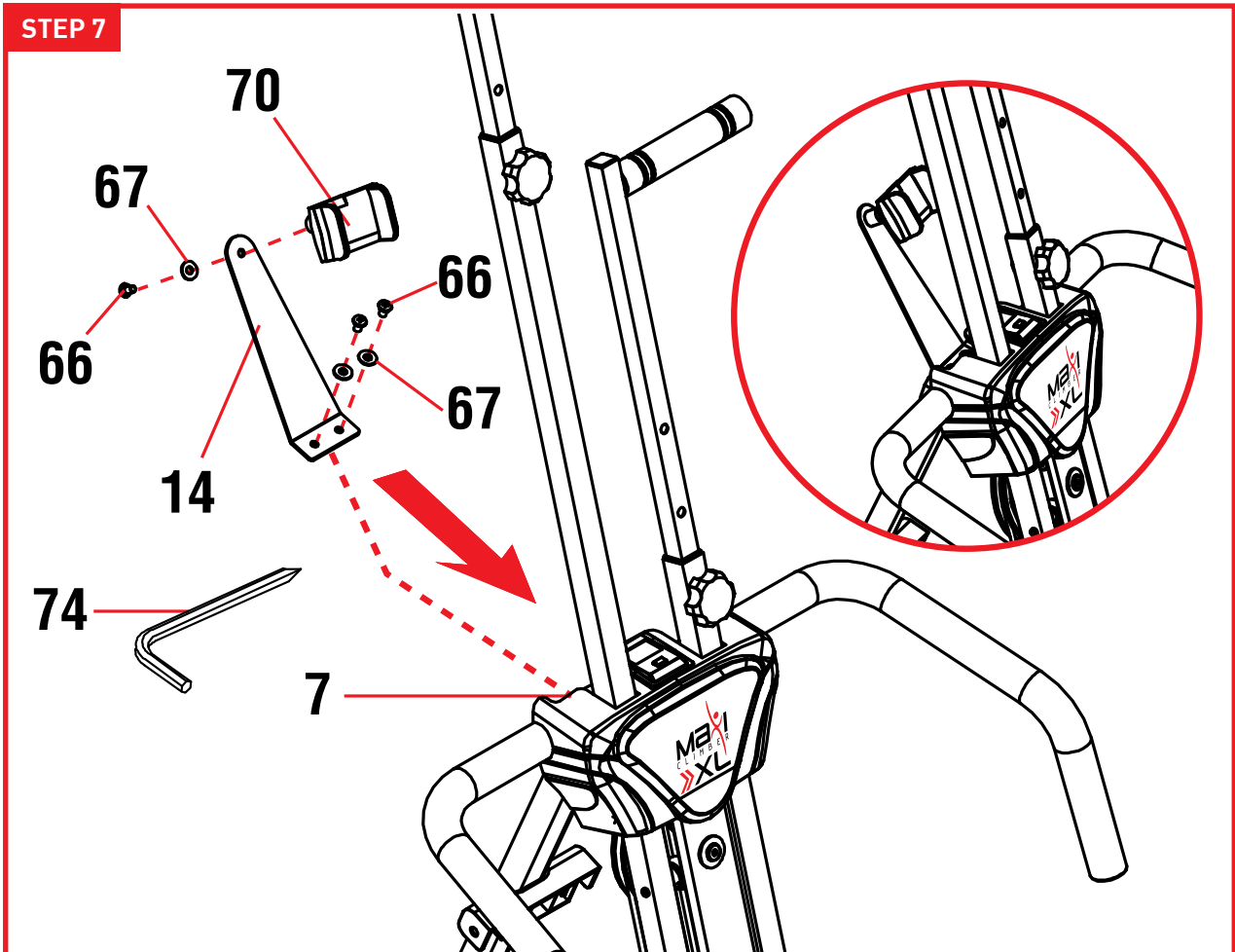

To adjust the pressure of the resistance pistons, turn the knob and align the number (1 low - 12 high) with the large arrow. Repeat in both pistons.

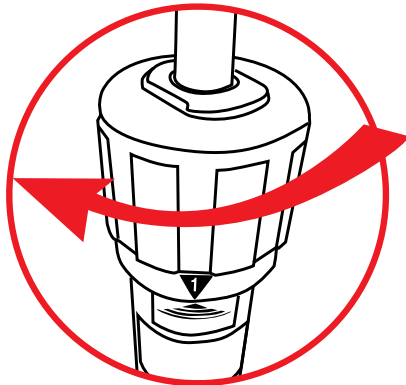

Detach the hydraulic cylinder from the adjusted tubes (8) and put back into the cylinder bracket.

READY TO USE!

Floor stabilizers can rotate to avoid movement on the floor.

Make sure that all pieces are well tightened before using the equipment.

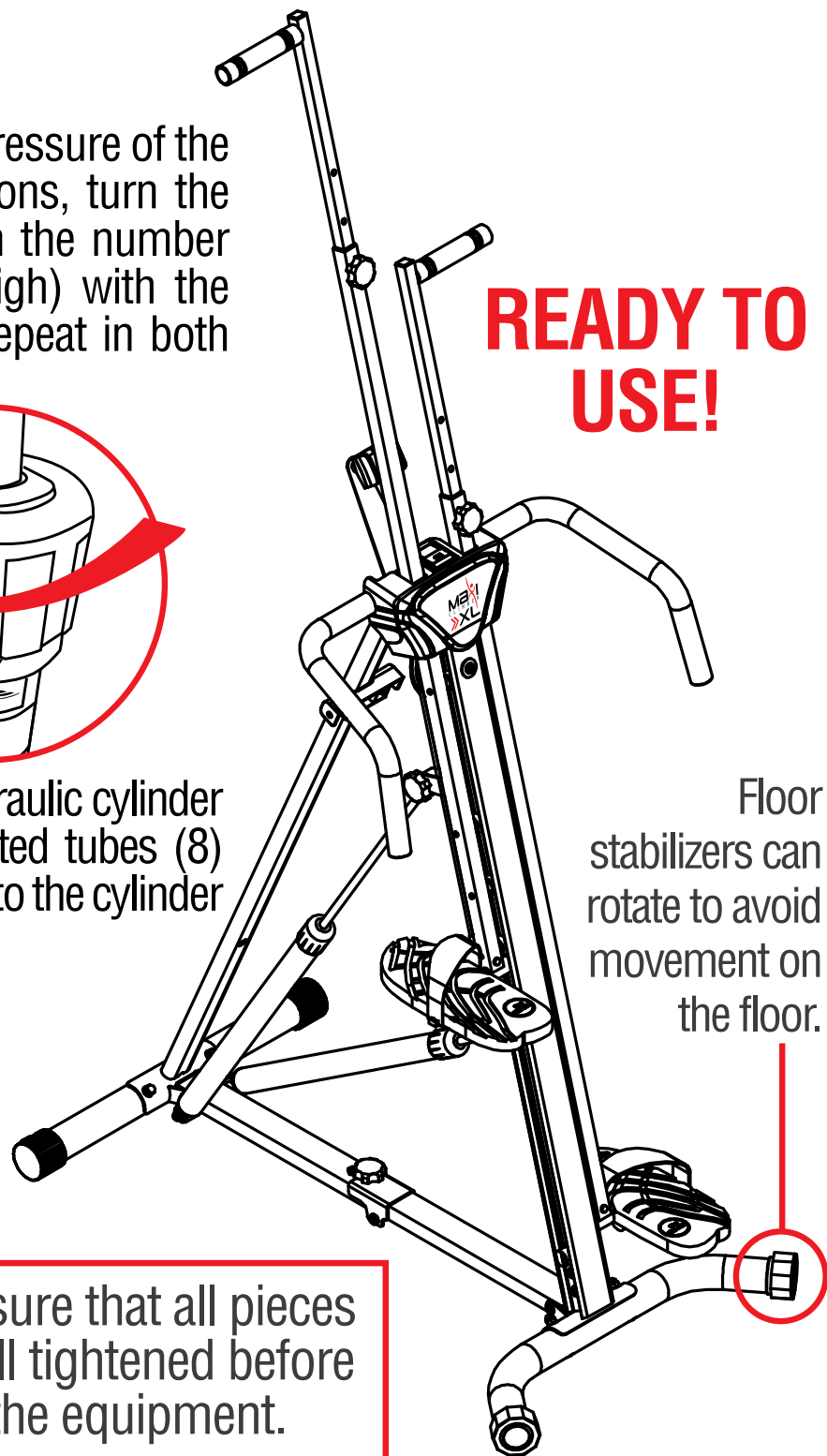

ELECTRONIC FITNESS MONITOR

KEYS

MODE/RESET: For selecting desired function. Hold down the key for 4 seconds and all values are reset to zero.

FUNCTIONS

- **SCAN:** Automatically scan functions of time, count, total count and calories. Each function will be displayed for 6 seconds.
- **TIME:** automatically accumulates the training time when exercising.
- **COUNT:** Automatically accumulates the steps of training when exercising.
- **TOTAL COUNT:** Automatically accumulates the Total number of steps made during different training sessions.
- **CALORIES:** Automatically accumulates calories burnt when exercising.

The monitor will turn on automatically if it detects activity on the machine. If it detects no activity for 4 minutes, the monitor will turn off automatically.

If you detect any abnormality in the monitor, replace the battery for a better result. The computer uses one LR44 button battery (1.5v).

BATTERY REPLACEMENT (Battery included)

1. Remove the calorie counter from the main body front cover part.
2. Take out the battery.
3. Replace the battery with a new one. Make sure the battery is inserted with the polarities in the correct directions.
4. Put the calorie counter back in the front cover of the main body.

- If the monitor doesn't display clearly or only partial segments appear, remove the battery and wait fifteen seconds before reinstalling.
- The batteries life is approximately 3 months under normal use.
- When the battery is removed, all function values return to zero.

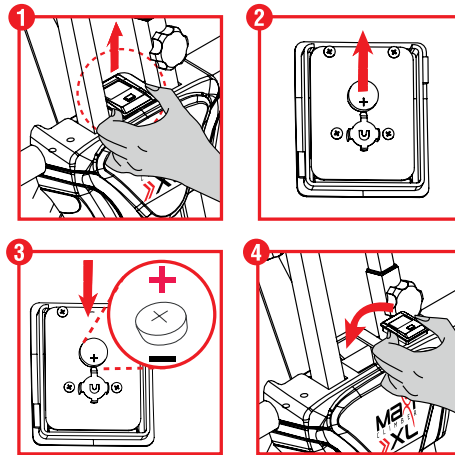

BATTERY CAUTION & DISPOSAL INFORMATION

1. For best results, use battery type LR44 (DC1.5V).
2. Install only new batteries of the same type in your product.
3. Failure to insert batteries in the correct polarity, as indicate in the battery compartment, may shorten the life of the batteries or cause batteries to leak.
4. Do not mix old and new batteries.
5. Do not mix Alkaline, Standard (carbon-zinc) or Rechargeable (nickel cadmium) or (Nickel Metal Hydride) batteries.
6. Do not dispose off batteries in fire.
7. Batteries should be recycled or disposed of as per state and local guidelines.

HOW TO MOUNT THE UNIT

1. Grab the right fixed handle with your right hand.

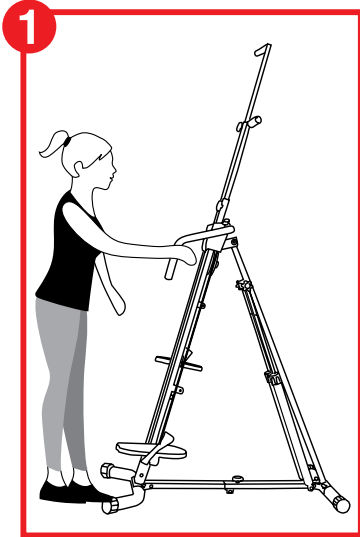

2. Without letting go the fixed handle, put your right leg over the right pedal.

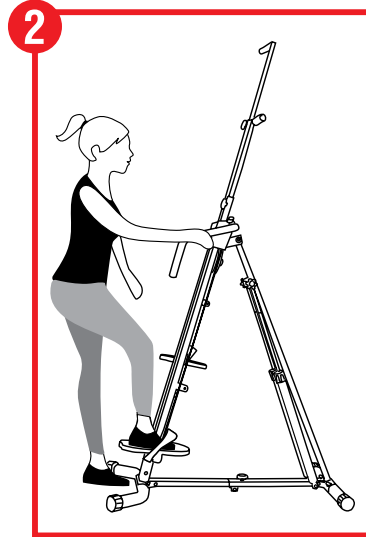

3. Climb and grab the left upper handle with your left hand.

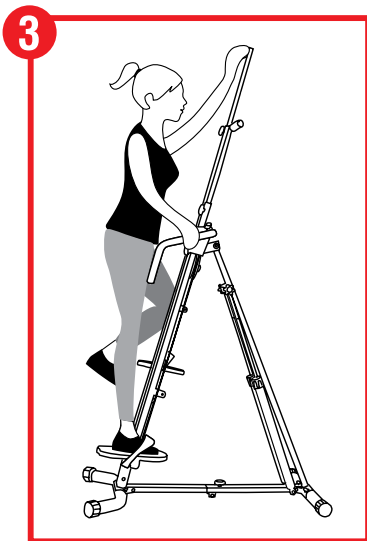

4. Finally put your left foot over the left pedal. Then put your right hand over the upper right handle. Start your exercise!

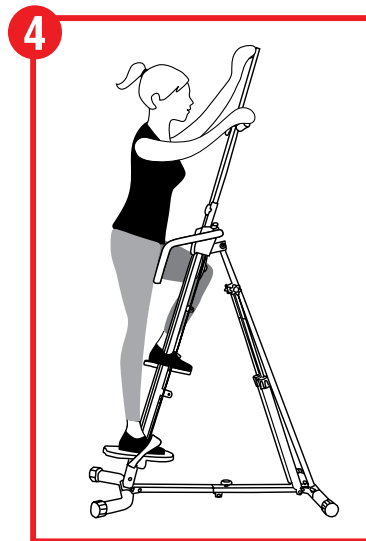

WARNING: PROPER POSITIONING

Avoid these positions for your own safety, do not pull back too much or you may fall with the unit. Keep your face away from the product to avoid hit it accidentally.

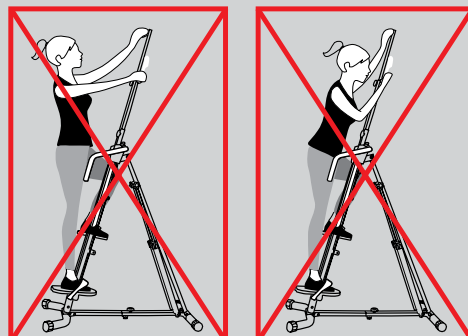

HOW TO STORAGE

1. Pull out the knob (25) of the base tube.
2. Loosen and pull the knob (25) from each side of the position A, release both cylinders (34) and move them into the cylinder bracket, then secure them with the knobs (25).
3. Fold up the base tubes, be careful to not pinch your fingers at the middle of the foldable tubes.
4. Insert the knob (25) taken from the base tubes at the back of the front support tube in order to secure position.

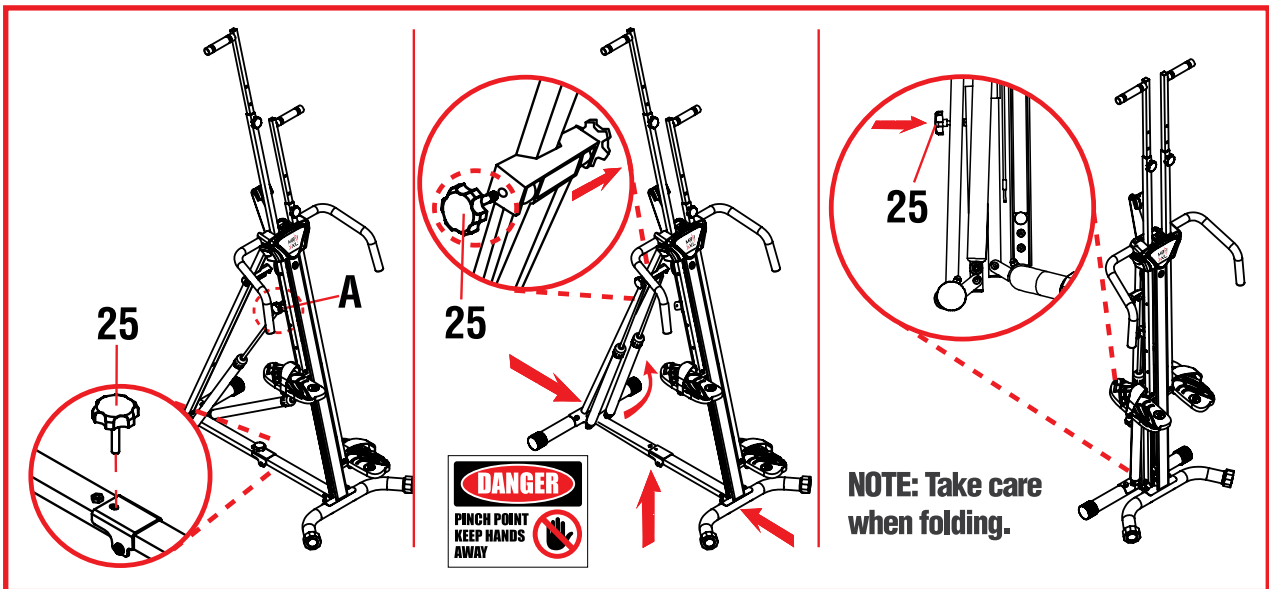

THIS PRODUCT IS FOR HOME USE ONLY, NOT SUITABLE TO BE USED IN PROFESSIONAL OR HEALTH FACILITIES OF ANY KIND.

CLAIMS ARE NOT ACCEPTED FOR PRODUCTS THAT HAVE THE FOLLOWING DETAILS.

- Hits.
- Falls.
- Misuse.
- Improper installation or assembly; excessive, commercial and / or professional use of the product.
- Damage caused by oxidation, sulphation, humidity, exposure to rain and / or water or excessive heat sources, use of abrasives, corrosion.
- Damages caused by the adaptation of parts and / or accessories that do not belong to the product.

RECOMMENDED EXERCISES

The use of this equipment will provide several benefits, improve your physical condition and muscle tone and combined with a controlled diet, will help you lose weight.

1. THE WARM UP PHASE

This stage helps get the blood flowing around the body and the muscles working properly. It will also reduce the risk of cramp and muscle injury. It is advisable to do a few stretching exercises as shown below. Each stretch should be held for approximately 30 seconds, do not force or jerk your muscles into a stretch - if it hurts, STOP.

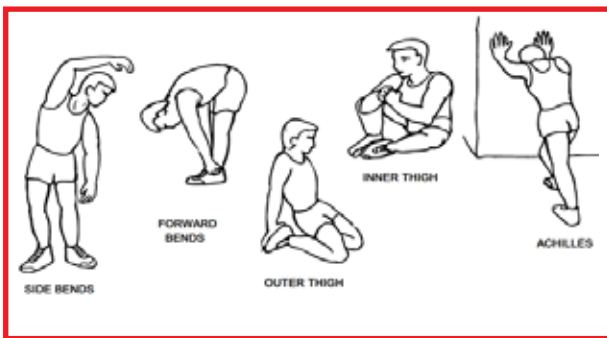

2. THE EXERCISE PHASE

This stage requires a greater degree of effort. After a while, your leg muscles will be more flexible. Maintain a constant exercise rhythm. The pace of the exercise should be such that the heart rate remains within the gray area of the graphic shown below.

This stage should last for a minimum of 12 minutes though most people start at about 15-20 minutes.

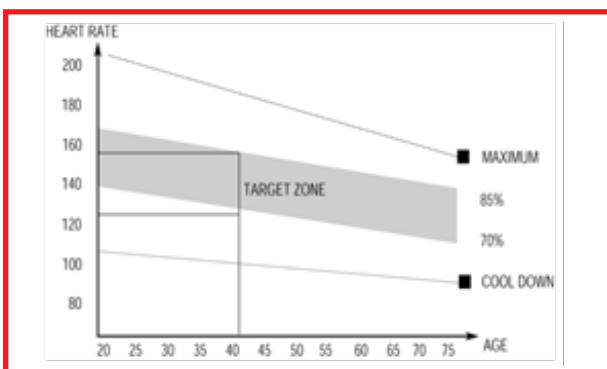

3. THE COOL DOWN PHASE

At this stage, the cardiovascular system and muscles must relax. Slow down and continue for 5 minutes. Stretching exercises should be repeated, remembering not to force the muscles.

As users become more athletic, you may need to train harder and longer times. It is suggested to train at least three times a week.

MUSCLE TONING

To tone your muscles while you are on the equipment, you will need to increase your resistance. This will strain muscles involved and you may not handle training the time you would like. If you want to improve your fitness you need to alternate your training plan. You should train naturally while warming up and cooling down, but towards the end of training you should increase resistance making your legs work more intensively.

You may have to reduce speed to keep your heart rate within the target zone.

WEIGHT LOSS

The important factor here is to increase the effort you put into the exercise. Stronger, lasting far as the workout, the more calories you burn. Is the same as when training to improve your fitness, the difference is the goal.

MAXICLIMBER® XL LIMITED WARRANTY ONE (1) YEAR (VALID ONLY FOR PURCHASES IN USA AND ITS TERRITORIES)

Warranty: Inova US ("Inova") warrants to the original MaxiClimber® XL purchaser ("Customer"), and only to the Customer, that the MaxiClimber® XL ("Product") for which the Customer received this warranty was designed, developed, manufactured and/or assembled using all due reasonable commercial care and good manufacturing practices. Inova US Product shall be, when properly assembled and used, free from defects in material and workmanship and fit for the ordinary purpose for which such Product is used for one (1) year from original date of purchase. Inova's sole obligation under this warranty is to repair or replace the Product, at Inova's option. Inova's obligations to the buyer hereunder shall be conditioned upon the buyer's notifying Inova of the claimed defect within thirty (30) days of the discovery thereof and upon the Product: (I) being returned, freight prepaid; (II) being found defective; (III) being found to have been properly assembled and used (if assembled and/or used); and (IV) being returned within one (1) year from the date of sale to the buyer.

Warranty and Liability Disclaimer: INOVA MAKES NO OTHER WARRANTIES OR REPRESENTATIONS OF ANY KIND WHATSOEVER, EXPRESS OR IMPLIED, EXCEPT THAT OF TITLE, AND ALL IMPLIED WARRANTIES INCLUDING ANY WARRANTY OF MERCHANTABILITY AND FITNESS FOR A PARTICULAR PURPOSE ARE HEREBY DISCLAIMED. Notwithstanding the foregoing, the duration of any implied warranty or condition of merchantability, fitness for a particular purpose, or otherwise, on the Product that may be found to be made shall be limited to the duration of the express warranty set forth above. In no event shall Inova be liable for any loss, inconvenience, damage, or personal injury, whether direct, incidental, consequential or otherwise, resulting from breach of any express or implied warranty or condition of merchantability, fitness for a particular purpose or otherwise with respect to the Product, or from use of the Product, except as set forth herein. Some states or countries do not allow limitation on how long an implied warranty lasts and some do not allow exclusions or limitations of incidental or consequential damages, so the above limitations or exclusions may not apply to you. This warranty gives you specific legal rights, and you may have other rights which may vary from location to location. This warranty will be interpreted pursuant to the laws of the United States and the State of Florida. The original English version (meaning) of this warranty controls over all translations; Inova is not responsible for any errors in translation of this warranty and/or any Product instructions. This warranty is not intended to confer any additional legal, jurisdictional or warranty rights to you other than those set forth herein or required by law. If any portion of this warranty is held to be invalid or unenforceable for any reason, such finding will not invalidate any other provision.

Warranty Service Options: For service under this warranty you must notify Inova in writing within 30 days to obtain a Returned Merchandise Authorization (RMA). When requesting your RMA, you must specify the Product in question by providing the order number.

TO OBTAIN ASSISTANCE in USA and its territories contact MaxiClimber® XL Customer Care Center:
Phone: (888) 433-9083
Email: customerservice@maxiclimber.com
Website: www.maxiclimber.com

Any insurance and/or shipping costs incurred in returning your Product under the approved Returned Material warranty option are your responsibility. Inova will not be responsible for any products lost or damaged in shipment.

Warranty Exclusions: Representatives and brokers of Inova products and services are not authorized to modify this warranty in any way. It is the Customer's responsibility to examine the Product regularly to determine the need for normal service or replacement. This warranty does not cover the following:

- Products that have been modified, neglected or poorly maintained, misused, abused, or involved in accidents or natural disasters;
- Damage occurring during shipment of the Product (such claims must be presented directly to the freight forwarder or shipping company);
- Damage to the Product resulting from improper maintenance or repair, the use or installation of parts and/or accessories that are not compatible with the original intended use of the Product, or the failure to follow the Product warnings and usage instructions or by anyone weighting more than 300 lb (136 kg);
- Any products for which the Customer does not follow the warranty procedures outlined above.

Warranty for other Countries/Territories see attached sheet.

BEFORE RETURNING THIS PRODUCT TO THE STORE

We will be happy to correct any problem that you may have or to answer any of your questions regarding the purchase of this product. Please contact us at our Toll-Free Customer Service Line (888) 433-9083

You may also e-mail us at customerservice@maxiclimber.com or visit our web site at maxiclimber.com

Thank you!

DISPUTE RESOLUTION BY BINDING ARBITRATION. PLEASE READ THIS CAREFULLY. IT AFFECTS YOUR RIGHTS.

Summary:

Most customer concerns can be resolved quickly and to the customer's satisfaction by calling our customer service department at (888) 433-9083. In the unlikely event that MaxiClimber® XL's customer service department is unable to resolve a complaint to your satisfaction (or if MaxiClimber® XL has not been able to resolve a dispute between us after attempting to do so informally or through mediation), we each agree to resolve those disputes through binding arbitration or small claims court instead of in courts of general jurisdiction. Arbitration is more informal than a lawsuit in court. Arbitration uses a NEUTRAL ARBITRATOR instead of a judge or jury. You thus GIVE UP YOUR RIGHT TO GO TO COURT to assert or defend your rights under this contract (EXCEPT for matters that may be taken to SMALL CLAIMS COURT). You are entitled to LEGAL REPRESENTATION and a FAIR HEARING, BUT the arbitration procedures, including discovery, are SIMPLER, MORE LIMITED AND USUALLY FASTER THAN PROCEEDINGS IN COURT. Arbitration decisions are as enforceable as any court order BUT ARE SUBJECT TO VERY LIMITED REVIEW BY A COURT. Arbitrators can award the same damages and relief that a court can award. Any arbitration under this Agreement will take place on an INDIVIDUAL BASIS; CLASS ARBITRATIONS AND CLASS ACTIONS ARE NOT PERMITTED. For any non-frivolous claim that does not exceed \$75,000, MaxiClimber® XL will pay all costs of the arbitration. Moreover, in arbitration you are entitled to recover attorneys' fees from MaxiClimber® XL to at least the same extent as you would be in court. In addition, under certain circumstances (as explained below), MaxiClimber® XL will pay you more than the amount of the arbitrator's award and will pay your attorney (if any) twice his or her reasonable attorneys' fees if the arbitrator awards you an amount that is greater than what MaxiClimber® XL has offered you to settle the dispute.

ARBITRATION AGREEMENT

(1) MaxiClimber® XL and you agree to arbitrate all disputes and claims between us. This agreement to arbitrate is intended to be broadly interpreted. It includes, but is not limited to:

- claims arising out of or relating to any aspect of the relationship between us, whether based in contract, tort, statute, fraud, misrepresentation or any other legal theory;
- claims that arose before this or any prior Agreement (including, but not limited to, claims relating to advertising);
- claims that are currently the subject of purported class action litigation in which you are not a member of a certified class; and
- claims that may arise after the termination of this Agreement.

References to "MaxiClimber® XL," "you," and "us" include our respective subsidiaries, affiliates, agents, employees, predecessors in interest, successors, and assigns, as well as all authorized or unauthorized users or beneficiaries of products and services under this or prior Agreements between us. Notwithstanding the foregoing, either party may bring an individual action in small claims court. This arbitration agreement does not preclude you from bringing issues to the attention of federal, state, or local agencies, including, for example, the Federal Trade Commission or Consumer Product Safety Commission. Such agencies can, if the law allows, seek relief against us on your behalf. You agree that, by entering into this Agreement, you and MaxiClimber® XL are each WAIVING THE RIGHT TO A TRIAL BY JURY OR TO PARTICIPATE IN A CLASS ACTION. This Agreement evidences a transaction in interstate commerce, and thus the Federal Arbitration Act governs the interpretation and enforcement of this provision. This arbitration provision shall survive termination of this Agreement.

(2) A party who intends to seek arbitration must first send to the other, by certified mail, a written Notice of Dispute ("Notice"). The Notice to MaxiClimber® XL should be addressed to: Office for Dispute Resolution, MaxiClimber® XL, 4095 State Road 7 Ste L216, Wellington, FL 33449 ("Notice Address"). The Notice must (a) describe the nature and basis of the claim or dispute; and (b) set forth the specific relief sought ("Demand"). If MaxiClimber® XL and you do not reach an agreement to resolve the claim within 30 days after the Notice is received, you or MaxiClimber® XL may commence an arbitration proceeding. During the arbitration, the amount of any settlement offer made by MaxiClimber® XL or you shall not be disclosed to the arbitrator until after the arbitrator determines the amount, if any, to which you or MaxiClimber® XL is entitled.

(3) After MaxiClimber® XL receives notice at the Notice Address that you have commenced arbitration, it will promptly reimburse you for your payment of the filing fee, unless your claim is for greater than \$75,000. (The filing fee currently is \$125 for claims under \$10,000 but is subject to change by the arbitration provider. If you are unable to pay this fee, MaxiClimber® XL will pay it directly upon receiving a written request at the Notice Address.) The arbitration will be governed by the Commercial Arbitration Rules and the Supplementary Procedures for Consumer Related Disputes (collectively, "AAA Rules") of the American Arbitration Association ("AAA"), as modified by this Agreement, and will be administered by the AAA. The AAA Rules are available online at adr.org, by calling the AAA at 1-800-778-7879, or by writing to the Notice Address. The arbitrator is bound by the terms of this Agreement. All issues are for the arbitrator to decide, except that issues relating

to the scope and enforceability of the arbitration provision are for the court to decide. Unless MaxiClimber® XL and you agree otherwise, or the arbitrator directs otherwise, any arbitration hearings will take place in the county of your billing address. If your claim is for \$10,000 or less, we agree that you may choose whether the arbitration will be conducted solely on the basis of documents submitted to the arbitrator, through a telephonic hearing, or by an in-person hearing as established by the AAA Rules. If your claim exceeds \$10,000, the right to a hearing will be determined by the AAA Rules. Regardless of the manner in which the arbitration is conducted, the arbitrator shall issue a reasoned written decision sufficient to explain the essential findings and conclusions on which the award is based. Except as otherwise provided for herein, MaxiClimber® XL will pay all AAA filing, administration, and arbitrator fees for any arbitration initiated in accordance with the notice requirements above. (Each party shall pay the fees and costs of its own counsel, experts and witnesses.) If, however, the arbitrator finds that either the substance of your claim or the relief sought in the Demand is frivolous or brought for an improper purpose (as measured by the standards set forth in Federal Rule of Civil Procedure 11(b)), then the payment of all such fees will be governed by the AAA Rules. In such case, you agree to reimburse MaxiClimber® XL for all monies previously disbursed by it that are otherwise your obligation to pay under the AAA Rules. In addition, if you initiate an arbitration in which you seek more than \$75,000 in damages, the payment of these fees will be governed by the AAA rules.

(4) If, after finding in your favor in any respect on the merits of your claim, the arbitrator issues you an award that is greater than the value of MaxiClimber® XL's last written settlement offer made before an arbitrator was selected, then MaxiClimber® XL will:

- pay you the amount of the award or \$5,000 ("the alternative payment"), whichever is greater; and
- pay your attorney, if any, twice the amount of attorneys' fees, and reimburse any expenses (including expert witness fees and costs) that your attorney reasonably accrues for investigating, preparing, and pursuing your claim in arbitration ("the attorney premium").

If MaxiClimber® XL did not make a written offer to settle the dispute before an arbitrator was selected, you and your attorney will be entitled to receive the alternative payment and the attorney premium, respectively, if the arbitrator awards you any relief on the merits. The arbitrator may make rulings and resolve disputes as to the payment and reimbursement of fees, expenses, and the alternative payment and attorney premium at any time during the proceeding and upon request from either party made within 14 days of the arbitrator's ruling on the merits.

(5) The right to attorneys' fees and expenses discussed in paragraph (4) supplements any right to attorneys' fees and expenses you may have under applicable law. Thus, if you would be entitled to a larger amount under the applicable law, this provision does not preclude the arbitrator from awarding you that amount. However, you may not recover duplicative awards of attorneys' fees or costs. Although under some laws MaxiClimber® XL may have a right to an award of attorneys' fees and expenses if it prevails in an arbitration, MaxiClimber® XL agrees that it will not seek such an award.

(6) The arbitrator may award declaratory or injunctive relief only in favor of the individual party seeking relief and only to the extent necessary to provide relief warranted by that party's individual claim. YOU AND MAXICLIMBER® XL AGREE THAT EACH MAY BRING CLAIMS AGAINST THE OTHER ONLY IN YOUR OR ITS INDIVIDUAL CAPACITY, AND NOT AS A PLAINTIFF OR CLASS MEMBER IN ANY PURPORTED CLASS OR REPRESENTATIVE PROCEEDING. Further, unless both you and MaxiClimber® XL agree otherwise, the arbitrator may not consolidate more than one person's claims, and may not otherwise preside over any form of a representative or class proceeding. If this specific provision is found to be unenforceable, then the entirety of this arbitration provision shall be null and void.

MAXI CLIMBER XL FULL-BODY WORKOUT

**MAXICLIMBER
FITNESS APP**
DOWNLOAD IT **FREE** >>>



YOUR PERSONAL FITNESS COACH ON DEMAND
MAXIMIZE YOUR ROUTINE AND BURN MORE CALORIES



inova[®]
Out of the Ordinary

IMPORTED AND DISTRIBUTED BY:
INOVA US
Wellington, FL 33449
www.maxiclimber.com
888-433-9083