

LoCo[®]

COOKERS

Owners Manual
Assembly Instructions

36" 3-Burner SmartTemp™ Precision Griddle

Patent Pending

Model: LCG3ST3C36



⚠ **WARNING** ⚠

READ INSTRUCTION MANUAL BEFORE ATTEMPTING TO ASSEMBLE OR OPERATE THIS PRODUCT.

Adult assembly required. Keep screws and parts out of reach of children.

INSTALLER: Leave these instructions with consumer.

CONSUMER: Retain these instructions for future reference.

This instruction manual contains important information necessary for the proper assembly and safe use of the appliance.

Read and follow all warnings and instructions before assembling and using the appliance.

Follow all warnings and instructions when using the appliance.

Keep this manual for future reference.

SAFETY SYMBOLS

Basic safety precautions should always be observed when using this appliance.

Read and understand the meaning of these symbols before assembling and using this appliance.

DANGER

Indicates a hazardous situation which, if not avoided, will result in serious injury or death.

WARNING

Be alert to the possibility of serious personal injury if the instructions are not followed.

CAUTION

Indicates a potentially hazardous situation which, if not avoided, could result in moderate injury.

DANGER

If you smell gas:

- Shut off gas to the appliance.
- Extinguish any open flame.
- Open lid.
- If odor continues, keep away from the appliance and immediately call your gas supplier or your fire department.

Failure to follow these instructions could result in fire or explosion which could cause property damage, personal injury or death.

WARNING

- Do not store or use gasoline or other flammable liquids or vapors in the vicinity of this or any other appliance.
- An LP cylinder not connected for use shall not be stored in the vicinity of this or any other appliance.
- If a fire should occur, keep away from the appliance and immediately call your fire department. Do not attempt to extinguish an oil or grease fire with water.

Failure to follow these instructions could result in fire, explosion or burn hazard which could cause property damage, personal injury or death.

WARNING:

This product can expose you to chemicals including lead and lead compounds, known to the State of California to cause cancer, birth defects or other reproductive harm. For more information, go to www.P65Warnings.ca.gov.

Equipped for use on: Propane
Main Max. Input Rating: 46,500 BTU/H
Certified under ANS Z21.58 - CSA 1.6-2018
Outdoor Cooking Gas Appliances

TABLE OF CONTENTS

Warnings.....	2, 4-7
Parts Diagram.....	8
Parts List.....	9
Hardware.....	10
Assembly Instructions.....	11-19
Leak Testing.....	20-21
Operation.....	21-23
Special Features.....	24-25
Care and Maintenance.....	26-29
Troubleshooting.....	30-32
Warranty.....	33

WARNINGS

SAVE THESE INSTRUCTIONS

- The installation must conform with local codes or, in absence of local codes, with the *National Fuel Gas Code*, ANSI Z223.1/NFPA 54, or the *Natural Gas and Propane Installation Code*, CSA B149.1, or the *Propane Storage and Handling Code*, CSA B149.2, or the *Standard for Recreational Vehicles*, ANSI A119.2/NFPA 1192, and CSA Z240 RV Series, *Recreational Vehicle Code*, as applicable.
- This appliance, when installed, must be electrically grounded in accordance with local codes or, in the absence of local codes, with the *National Electric Code*, ANSI/NFPA 70, or the *Canadian Electric Code, Part I*, CSA C22.1.
- This appliance is for use with liquid propane (LP) gas only. The conversion to or attempted use of natural gas in this LP appliance is dangerous and may cause bodily harm.
- Never use charcoal, lighter fluid, lava rocks, gasoline, kerosene or alcohol with this appliance.
- This appliance is for **outdoor use only**. Never use this appliance in a building, garage or any other enclosed area.
- Never install or use this appliance in or on a boat or recreational vehicle.
- Maintain proper clearances from combustible construction. The minimum clearance to the sides and back of the appliance is 36" (914 mm) from any structure or combustible material. Do not locate or use the appliance under overhead combustible construction.
- Never operate this appliance on or under any apartment or condominium balcony or deck.
- Keep the electrical supply cord and the fuel supply hose away from any heated surfaces.
- This appliance is not intended for commercial use.
- The use of alcohol, prescription drugs or non-prescription drugs may impair the consumer's ability to properly assemble or safely operate the appliance. Do not operate when under the influence.
- When cooking with oil or grease, have a Type BC or ABC fire extinguisher readily available.
- In the event of an oil or grease fire do not attempt to extinguish with water. Immediately call the fire department (911). A Type BC or ABC fire extinguisher may, in some circumstances, contain the fire.
- When cooking, the appliance must always be on a level, stable, noncombustible surface such as brick, concrete or dirt and in an area free of combustible materials. Never use this appliance on or around surfaces such as asphalt, wood, dry grass or leaves, vinyl or plastic. These surfaces are combustible and may melt or catch fire.
- Do not leave the appliance unattended. Keep children and pets away from the appliance at all times.
- Do not leave the appliance unattended while preheating or burning off food residue. If the appliance has not been cleaned, a grease fire can occur that may cause damage.
- Do not move the appliance while in use. Allow the appliance to cool before moving or storing.
- Do not attempt to disconnect the regulator from the gas cylinder or any gas fitting while the appliance is in use.
- The LP gas cylinder must be properly disconnected and removed before moving this appliance.
- This appliance is not intended for and should never be used as a heater.
- This appliance will be hot during and after use. Use insulated mitts or gloves for protection from hot surfaces or splatter. Closed-toed shoes should always be worn during operation of this appliance.
- Avoid bumping of or impact with the appliance to prevent spillage or splashing of hot cooking liquid.

WARNINGS

- Use caution when in close proximity to this appliance. Falling or tripping near the appliance may result in the splashing or igniting of hot cooking liquids and potentially cause personal injury or property damage.
- Never drop food or accessories onto the cooking surface. Lower food and accessories slowly onto the cooking surface in order to prevent splashing. When removing food from the appliance, care shall be taken to avoid burns from hot cooking liquids.
- Use caution when placing anything on the cooking surface while the appliance is in operation.
- The pressure regulator and hose assembly supplied with the appliance must be used. Replacement pressure regulators and hose assemblies shall be those specified by the appliance manufacturer.
- Keep the cooking area adjacent to the appliance clear of debris and free of anything flammable or combustible.
- Never attempt to attach this appliance to the self-contained LP gas system of a camper, trailer or motor home.
- Check burner/venturi tubes for insects and insect nests and clean if necessary. A clogged tube can lead to a fire beneath the appliance.
- Do not store or use gasoline or other flammable liquids or vapors within 25 ft (7.6 m) of this appliance.
- Do not alter the appliance in any manner. Do not use the appliance until it is completely assembled and all parts are securely fastened and tightened.
- Do not build this appliance into any built-in or slide-in construction. This could cause a fire or an explosion that can damage property and cause serious bodily injury or death.
- Use only factory-authorized replacement parts. The use of any part that is not factory-authorized can be dangerous.
- Failure to raise the side shelves while igniting the burners, or not waiting 5 minutes to allow gas to clear if the burners do not light, may result in an explosive flare-up.
- To protect against electric shock, do not immerse cord or plugs in water or other liquid.
- Unplug from the outlet when not in use and before cleaning. Allow the appliance to cool before putting on or taking off parts.
- Do not operate and outdoor cooking gas appliance with a damaged cord, plug, or after the appliance malfunctions or has been damaged in any manner. Contact the manufacturer for repair.
- Do not let the cord hang over the edge of a table or touch hot surfaces.
- Do not use this appliance for purposes other than intended.
- When connecting, first connect plug to the appliance, then plug appliance into the outlet.
- Use only a Ground Fault Interrupter (GFI) protected circuit with this appliance.
- Use only the power supply cord supplied by manufacturer.
- The manufacturer has properly located the burners with respect to the orifices to allow the appliance to burn sufficiently. Please do not attempt to adjust the burners. They are preset to the factory specifications.

WARNINGS: LP TANK

⚠ DANGER ⚠

1. Do not store a spare LP gas cylinder under or near this appliance.
2. NEVER fill the cylinder beyond 80% full.
3. If the instructions in 1 and 2 are not followed exactly, a fire causing serious injury or death may occur.

The safety release valve on the LP tank could activate the leaking of gas and cause a severe fire and increase the risk of serious injury or death.

⚠ DANGER ⚠

- If you smell, see or hear leaking gas, IMMEDIATELY get away from the LP tank and contact your FIRE DEPARTMENT (911).
- Only cylinders marked “propane” shall be used.
- Never use a cylinder with a damaged body, valve, collar or footing. Dented or rusted cylinders may be hazardous and should be checked by your LP gas supplier before use. The cylinder should not be dropped or handled roughly.
- Never keep a cylinder in a hot car or trunk. Heat will cause the gas pressure to increase which may open the relief valve and allow gas to escape.

Liquefied Petroleum Gas (LP):

- LP gas is odorless, non-toxic and colorless when produced. For your safety, LP gas has been given an odor (similar to rotten eggs) so you can smell if there is any leaking.
- LP gas is highly flammable and can unexpectedly ignite when combined with air.

LP TANK REMOVAL, TRANSPORT AND STORAGE

1. Turn control knobs and LP tank valve OFF. Turn coupling nut counterclockwise by hand only. Never use tools to disconnect.
2. Place dust cap on cylinder valve outlet whenever the cylinder is not in use. Only install the type of dust cap on the cylinder valve outlet that is provided with the cylinder valve. Other types of caps or plugs may result in leakage of propane.
3. A disconnected LP tank in storage or being transported must have a safety cap installed.
4. The cylinder must be stored outdoors out of reach of children. NEVER store the cylinder in enclosed spaces such as a garage, carport, covered porch or any other structure.
5. When the appliance is not in use, the gas must be turned off at the supply cylinder.
6. Storage of an appliance indoors is permissible only if the cylinder is disconnected and removed from the appliance.
7. The cylinder must be disconnected when the appliance is not in use.



Dust Cap

LP TANK

The LP tank must meet the following requirements in order to be used with your appliance:

- Measurements must be 12" (30.5 cm) in diameter by 18" (45.7 cm) high with 20 lb (9.1 kg) maximum capacity.
- The LP gas supply cylinder to be used must be constructed and marked in accordance with the *Specifications for LP Gas Cylinders* of the US Department of Transportation (DOT) or the Standard

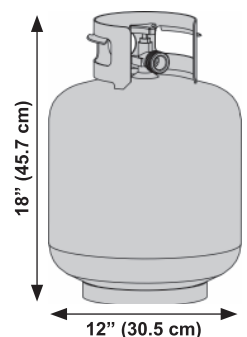

WARNINGS: LP TANK

for *Cylinders, Spheres and Tubes for the Transportation of Dangerous Goods and Commission, CAN/CSA-B339.*

The LP tank must include the following:

- A cylinder connection device compatible with the connection for outdoor cooking appliances.
- Safety relief valve.
- A Listed Overfill Protection Device (OPD). This safety device is identified by the triangular hand wheel. Only use tanks equipped with this type of valve.
- LP tank must be arranged for vapor withdrawal and include collar that protects LP tank valve.

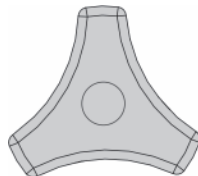

OPD Hand Wheel

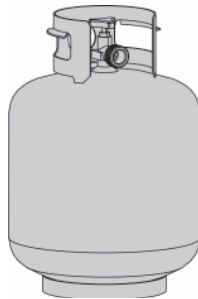

Proper upright cylinder orientation



DANGER



NEVER insert any tool or foreign object into the LP tank valve outlet or safety relief valve. You may damage the valve or cause a leak which can lead to explosion, fire, personal injury or death.

PARTS DIAGRAM

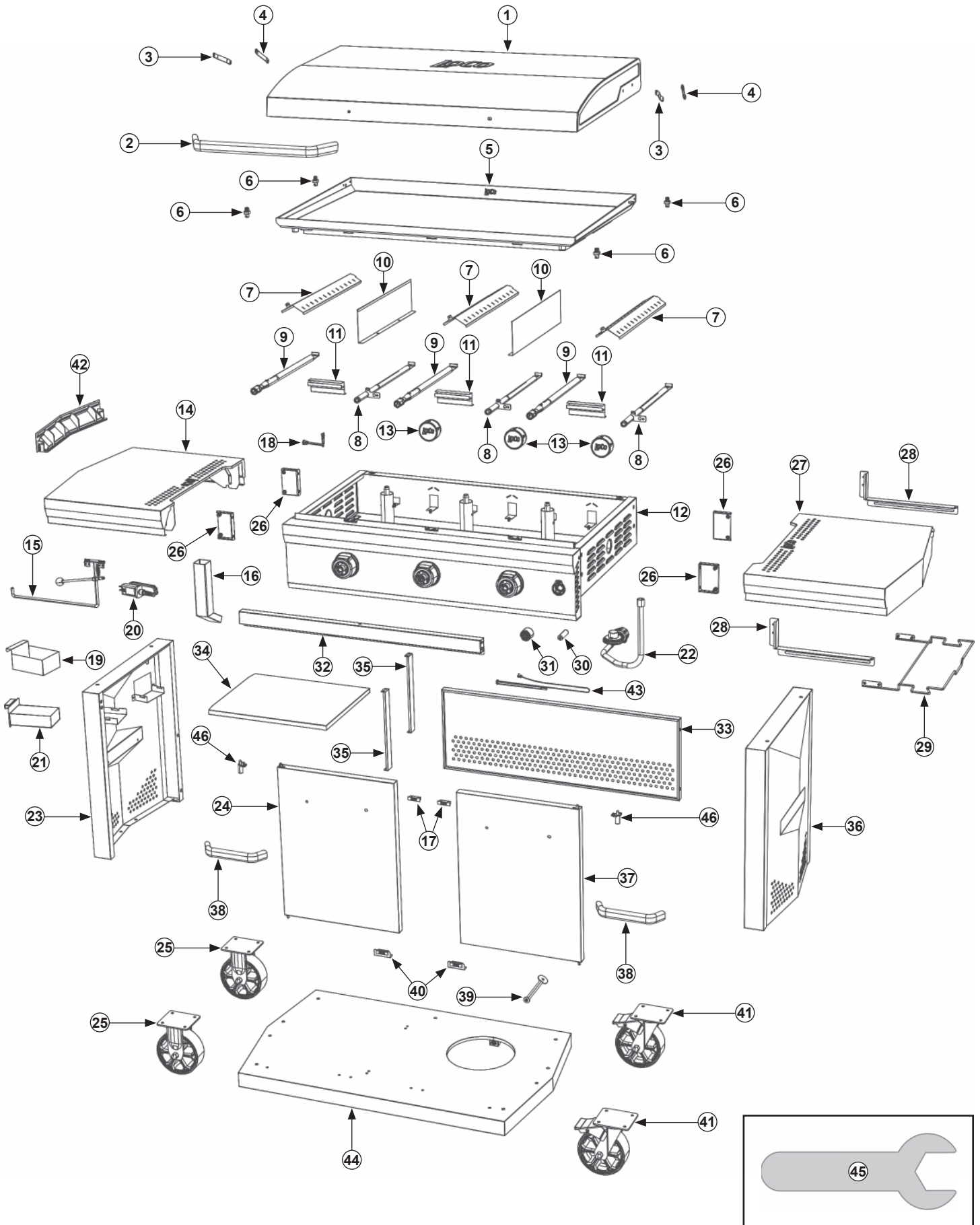

PARTS LIST

Part #	Description	Qty	Part #	Description	Qty
1	Lid	1	24	Cart Door, Left	1
2	Lid Handle	1	25	Wheel (Non-Locking)	2
3	Lid Hinge Bracket, Long	2	26	Side Shelf Bracket	4
4	Lid Hinge Bracket, Short	2	27	Side Shelf, Right	1
5	Cooktop	1	28	Trash Bag Rack Support	2
6	Cooktop Locking Foot	4	29	Trash Bag Rack	1
7	Burner Tent	3	30	AA Battery	1
8	Burner Tube, Pilot	3	31	Ignition Button and Bezel	1
9	Burner Tube, Non-Pilot	3	32	Cart Brace, Front	1
10	Burner Box Divider	2	33	Cart Panel, Back	1
11	Gas Carryover Channel	3	34	Tank Exclusion Shelf	1
12	Burner Box, Complete	1	35	Tank Exclusion Shelf Leg	2
13	Control Knob	3	36	Cart Panel, Right	1
14	Side Shelf, Left	1	37	Cart Door, Right	1
15	Paper Towel Rack	1	38	Door Handle	2
16	Grease Chute	1	39	Tank Retention Screw	1
17	Upper Door Magnet	2	40	Lower Door Magnet	2
18	Power Port	1	41	Caster (Locking)	2
19	Power Cord Storage Tray	1	42	Tool Hooks	1
20	Power Cord	1	43	Match Holder w/Chain	1
21	Grease Tray	1	44	Cart Base	1
22	Regulator w/Hose	1	45	Cooktop Adjustment Wrench	1
23	Cart Panel, Left	1	46	Upper Door Hinge	2

Contact customer service if any parts are missing, damaged or if replacement parts are needed.

800-391-0436 • customerservice@lococookers.com • lococookers.com

HARDWARE

A

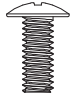

M4x10 Screw
Qty. 21

B

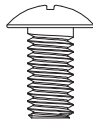

M6x12 Screw
Qty. 49

C

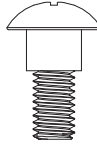

M6x10 Screw
Qty. 8

D

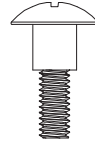

M4x10 Screw
Qty. 5

E



M4 Hex Nut
Qty. 2

Tools required: Phillips head screwdriver • Adjustable wrench

(Not included)

Cooktop adjustment wrench

(Included)

Two people required for assembly.



ASSEMBLY INSTRUCTIONS

1

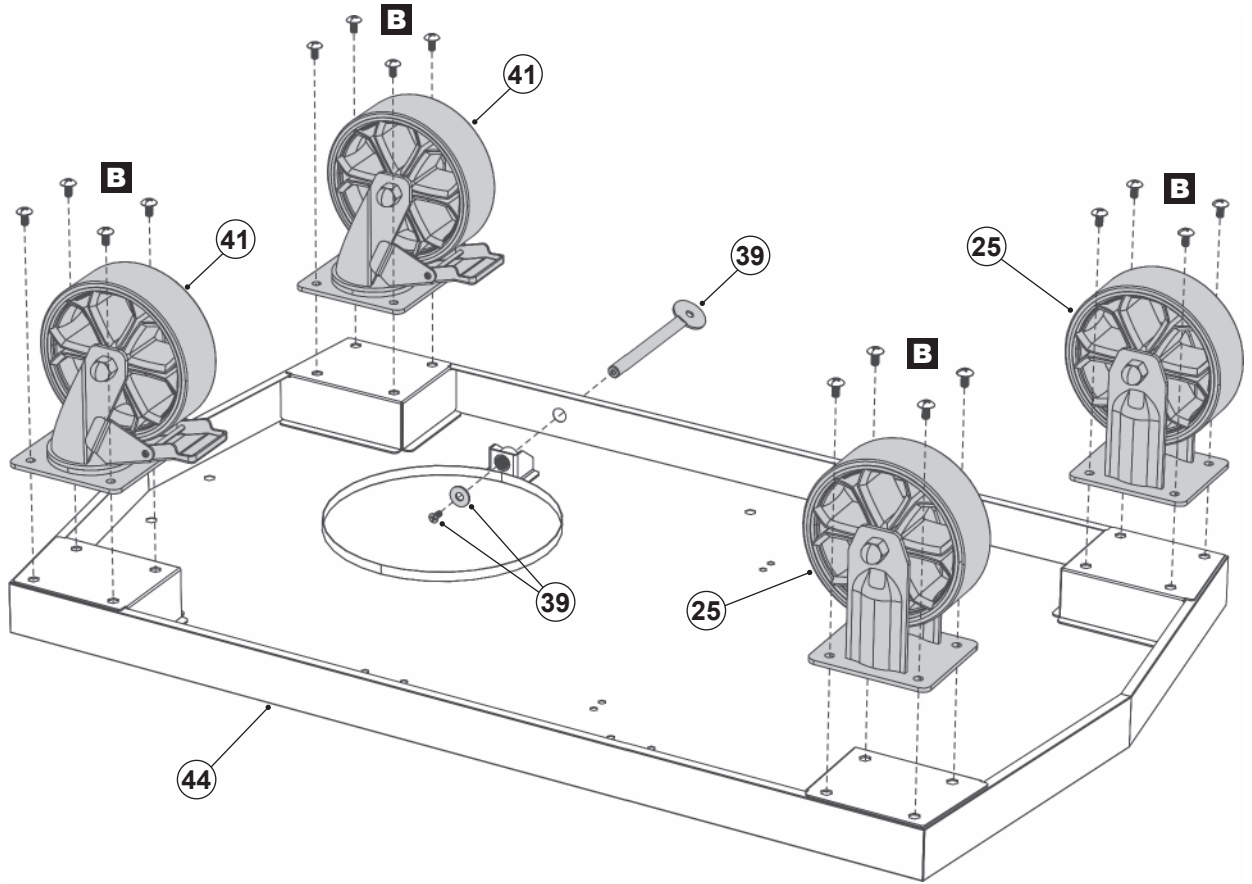

2

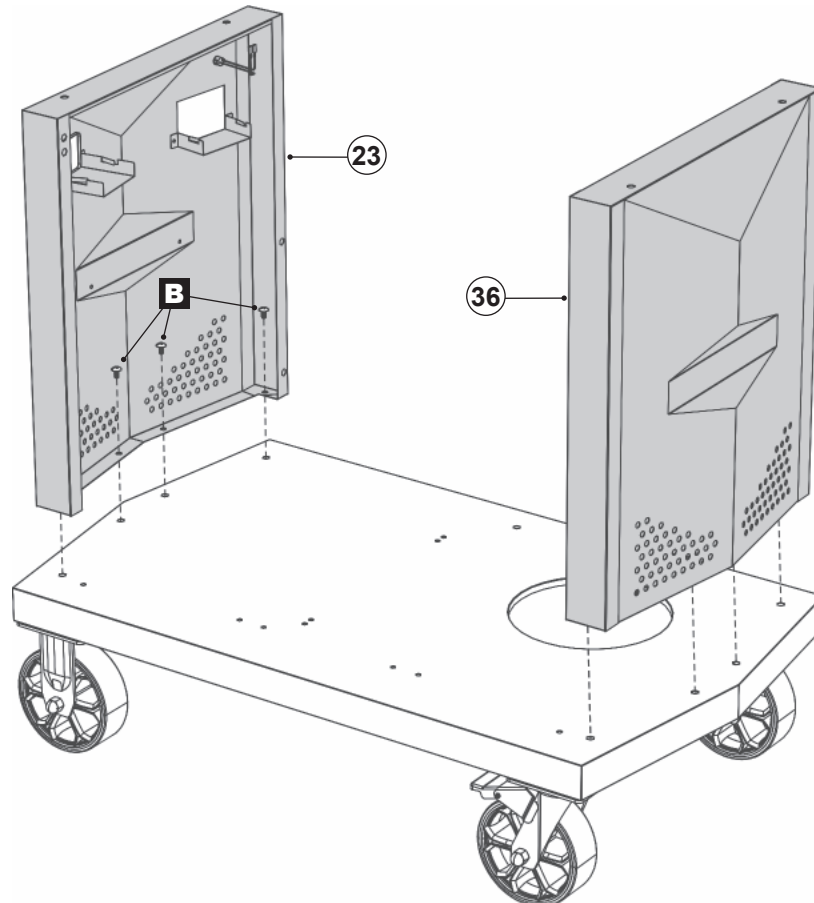

ASSEMBLY INSTRUCTIONS

3

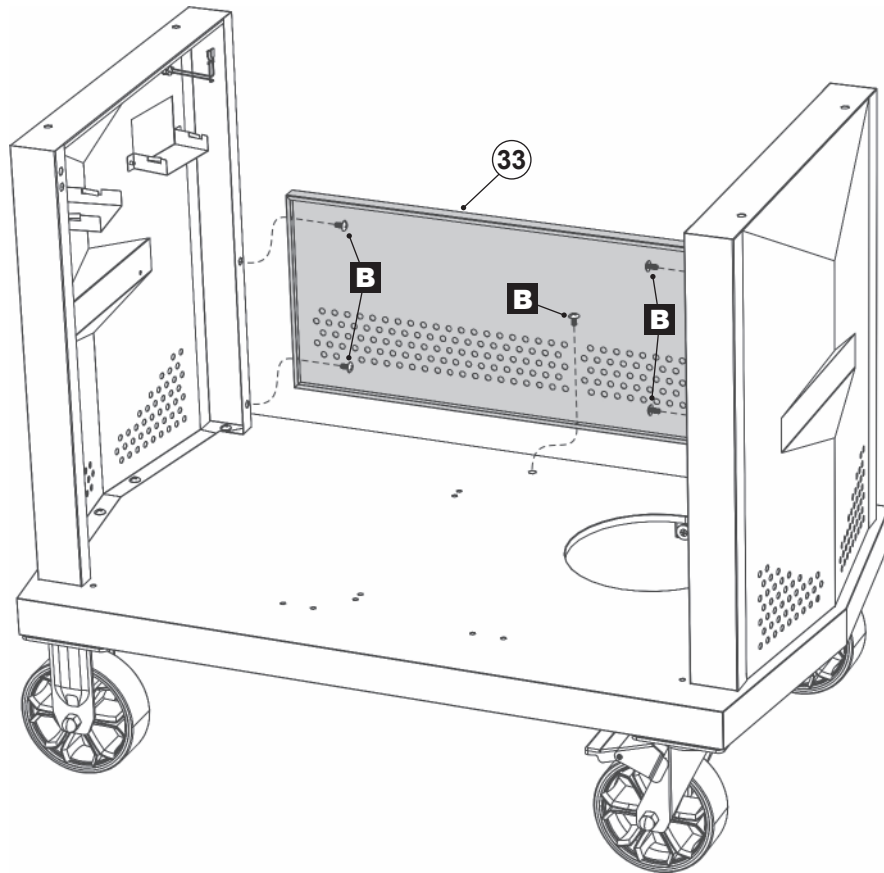

4

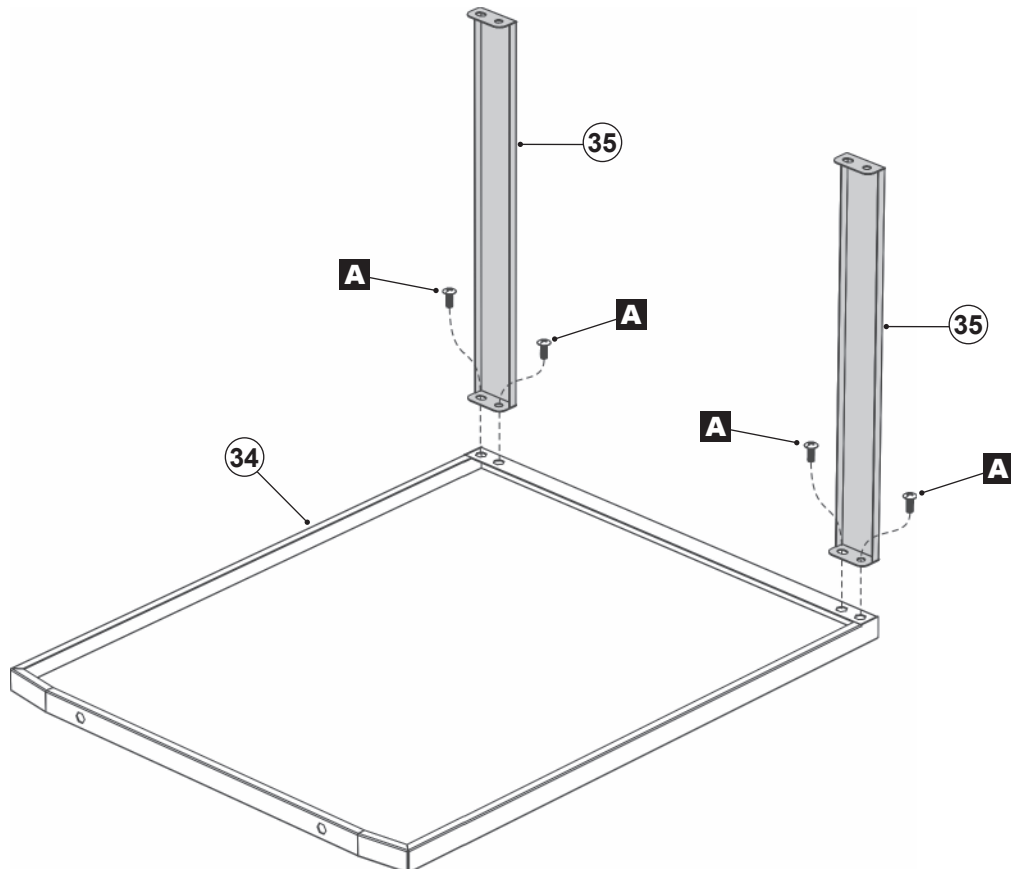

ASSEMBLY INSTRUCTIONS

5

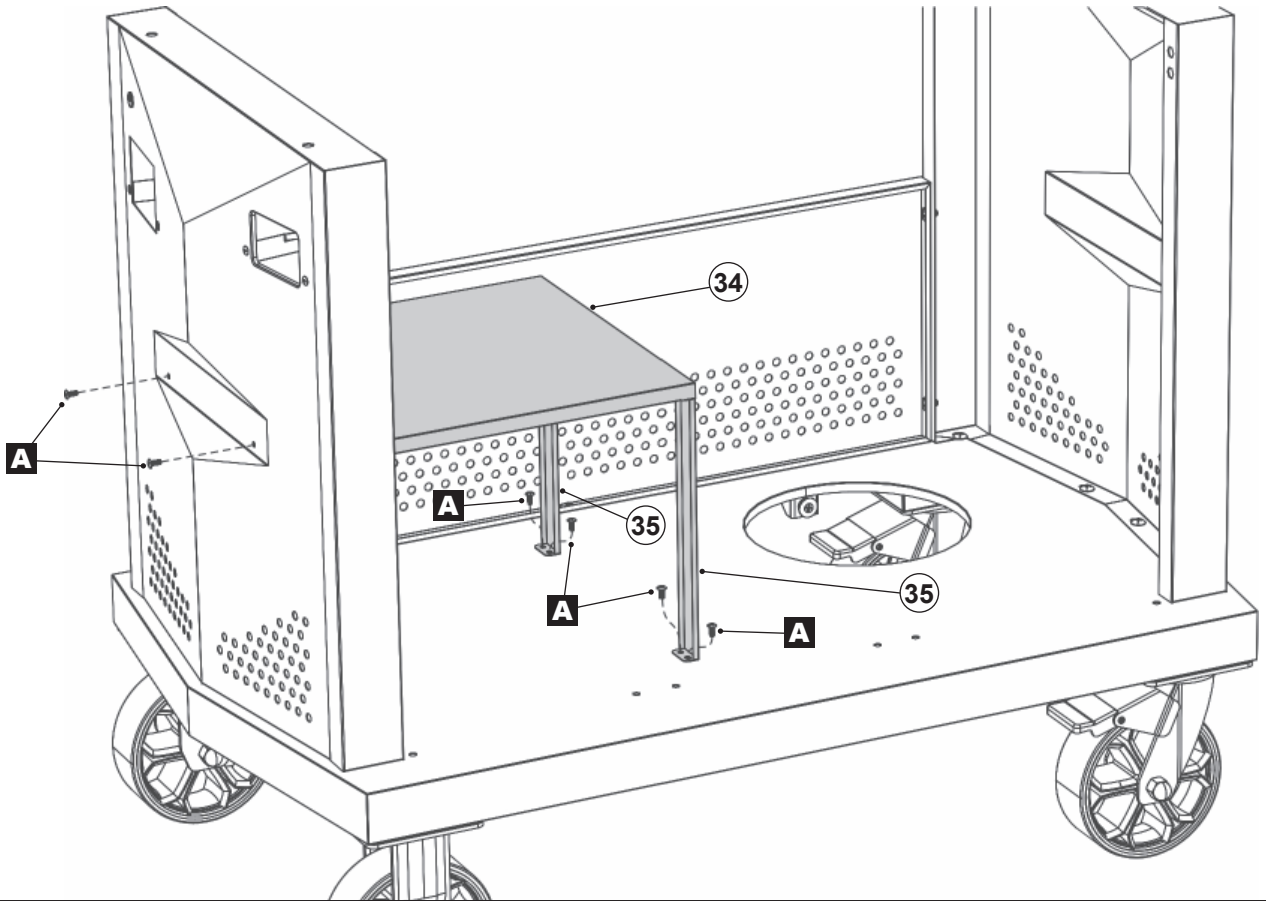

6

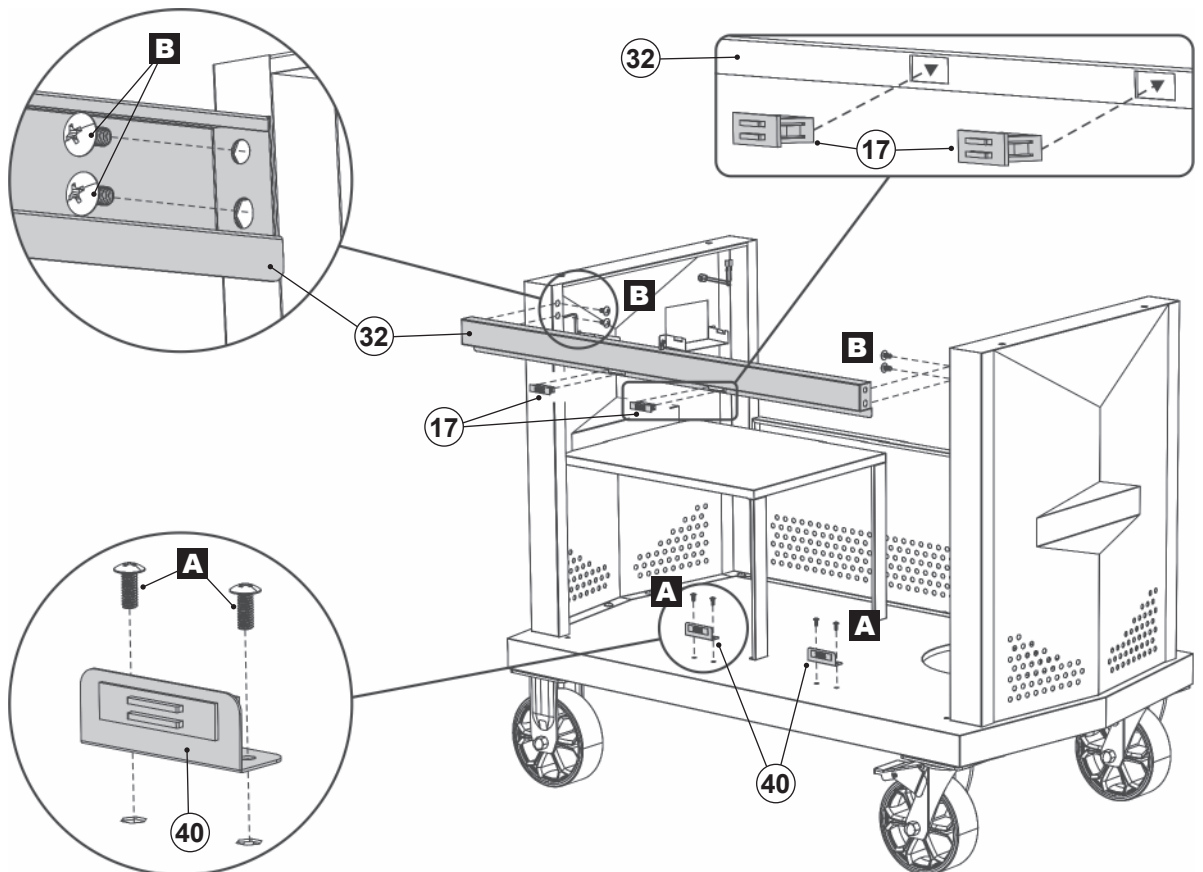

ASSEMBLY INSTRUCTIONS

7

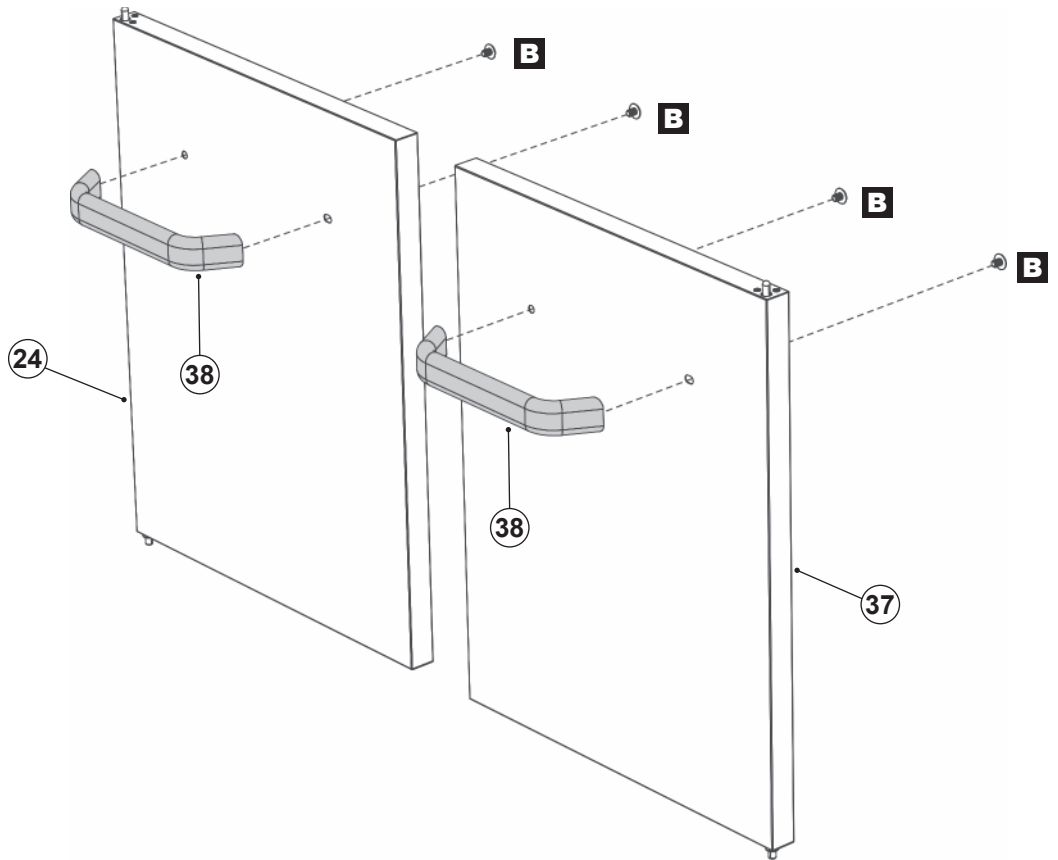

8

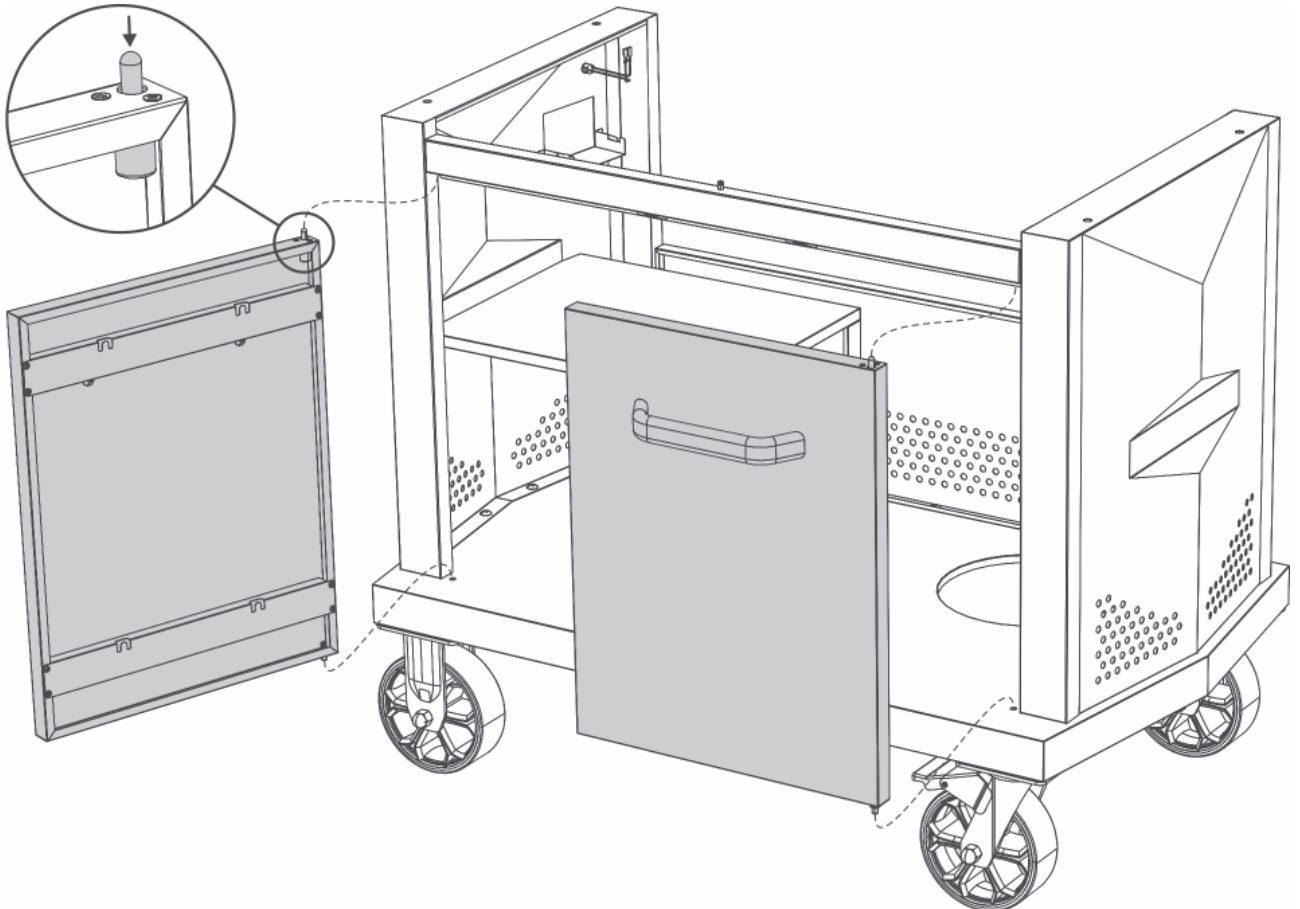
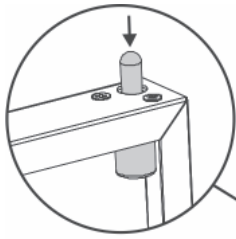

ASSEMBLY INSTRUCTIONS

9

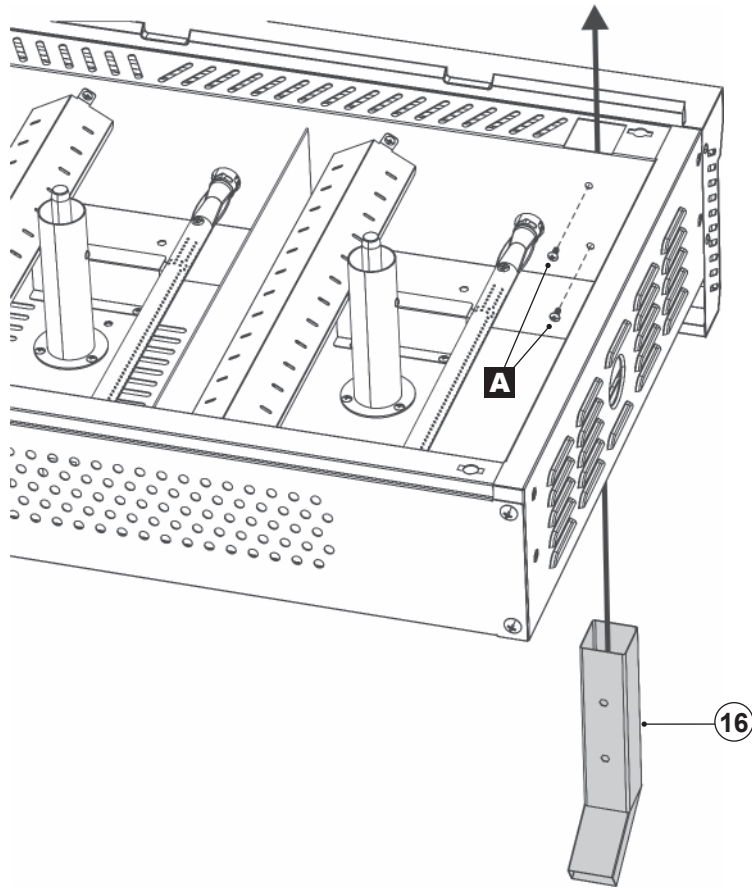

10

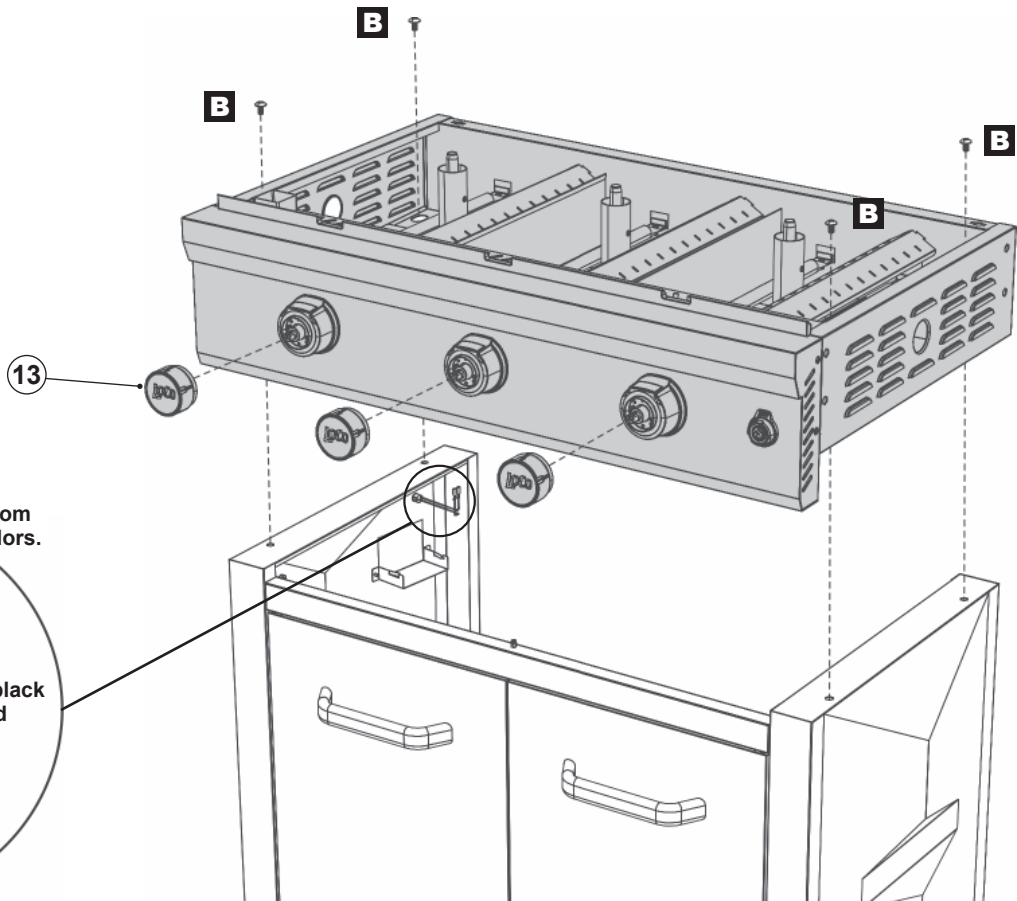

Slide white insulation back from connectors to identify wire colors.

Match wire colors.
• Black to black
• Red to red

18

ASSEMBLY INSTRUCTIONS

11

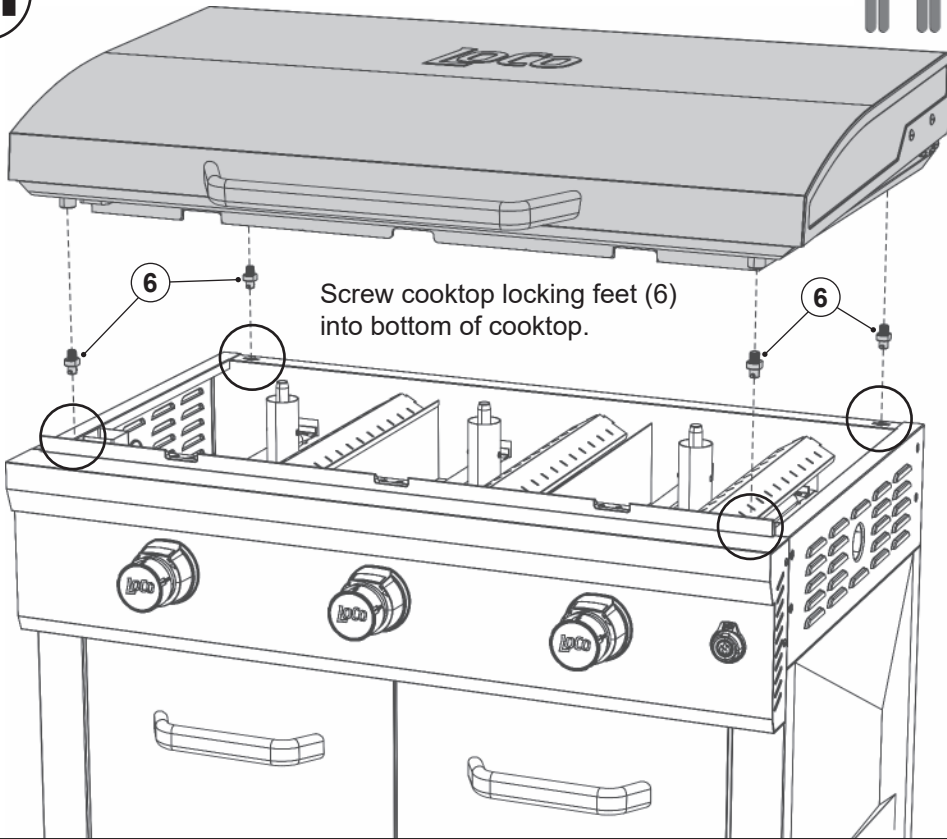

Screw cooktop locking feet (6) into bottom of cooktop.

Use included adjustment wrench. See page 24 "Integrated Grease Management."

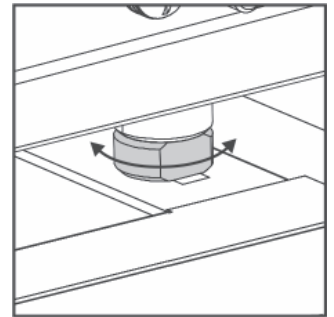
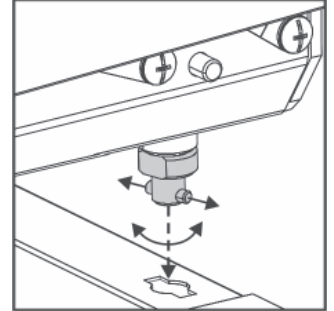

12

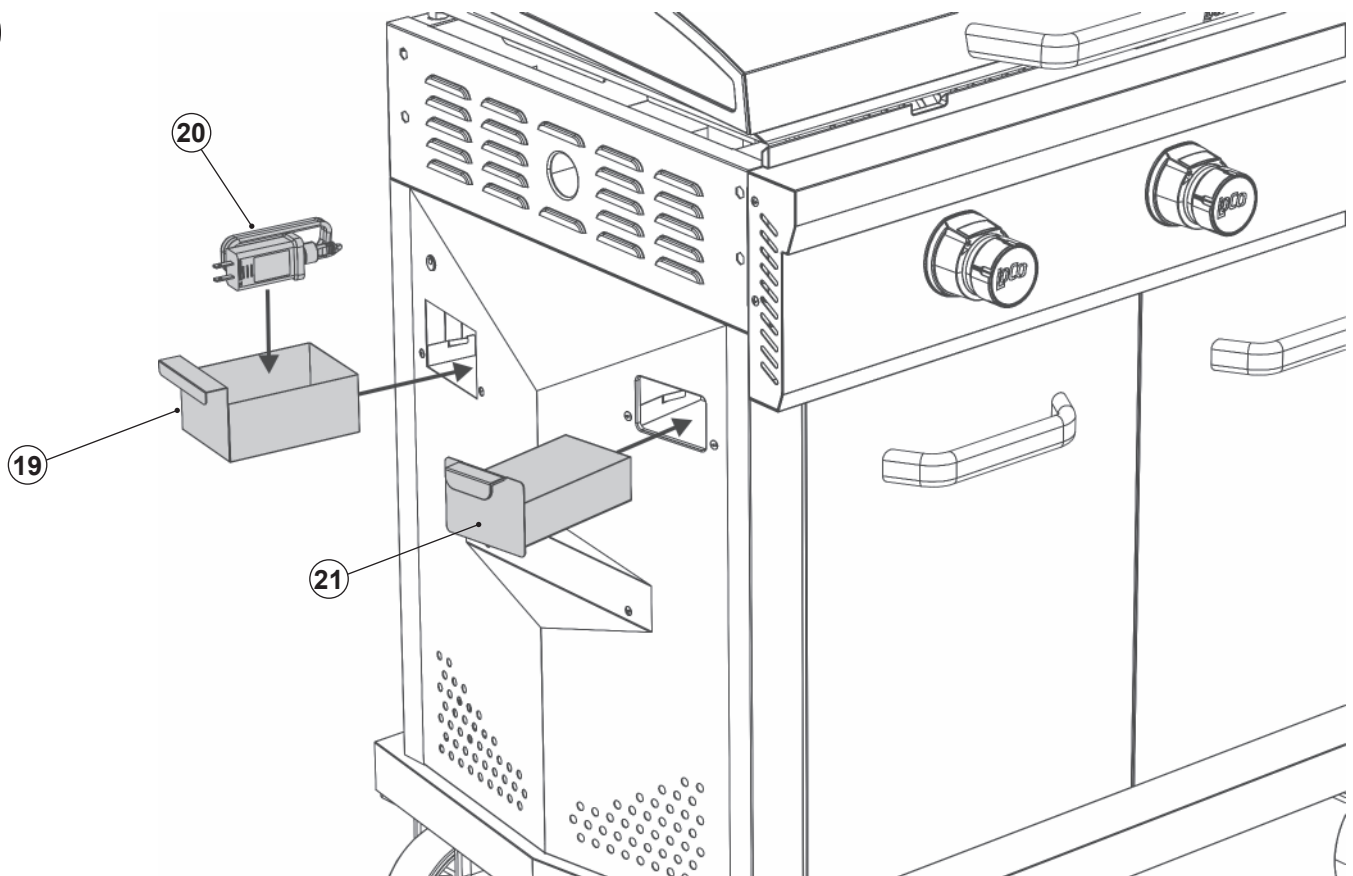

ASSEMBLY INSTRUCTIONS

13

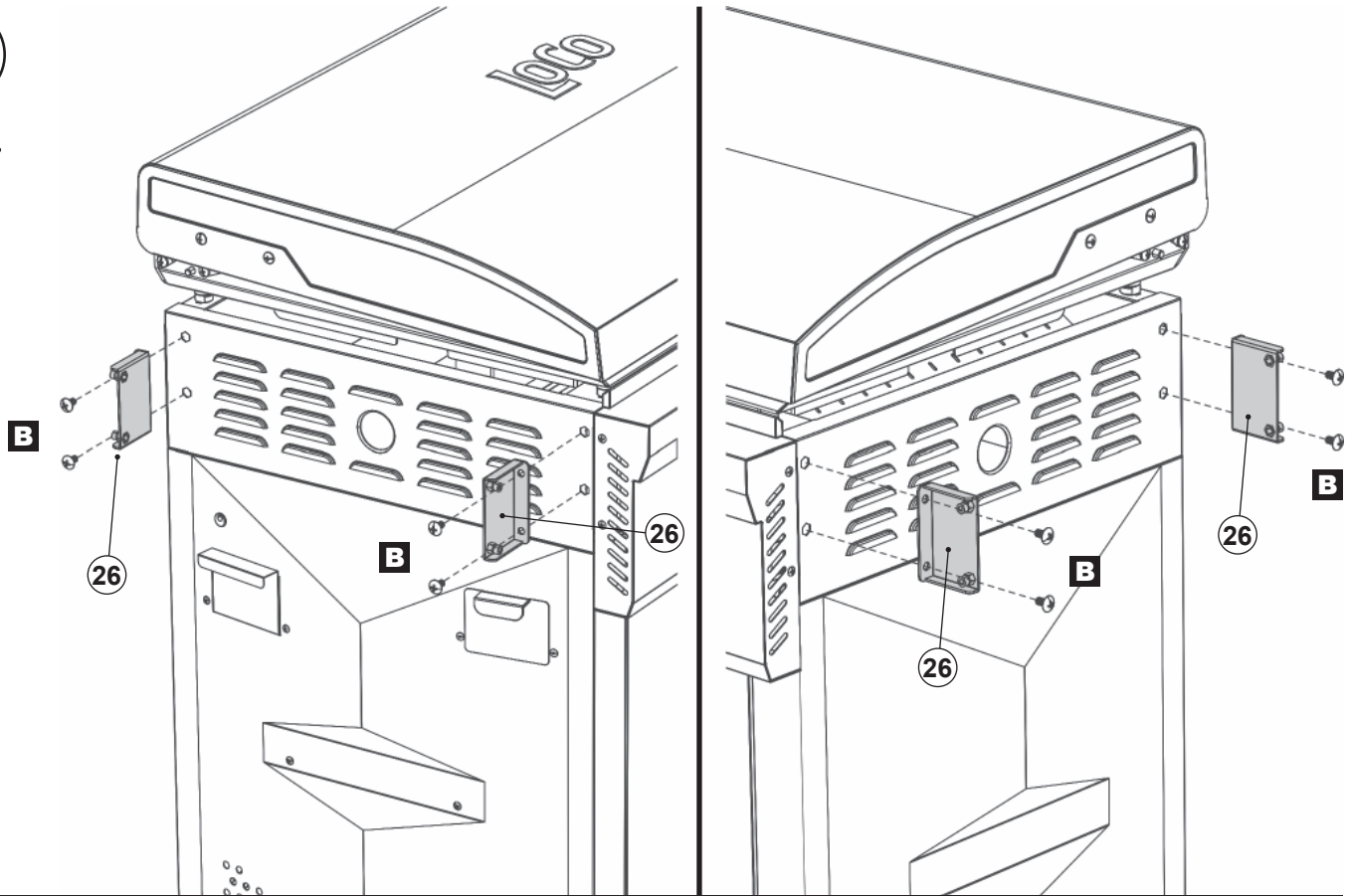

14

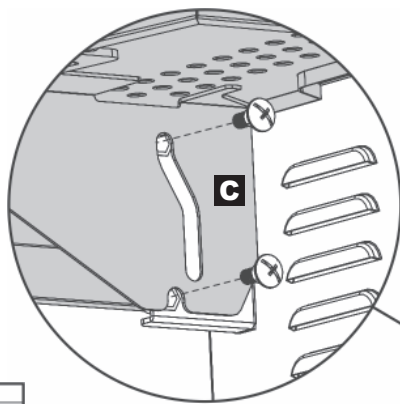
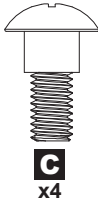

Repeat on front shelf bracket.

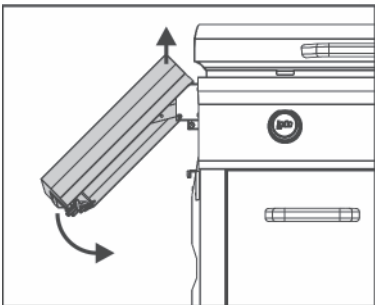

To lower side shelf, lift upward and rotate downward.

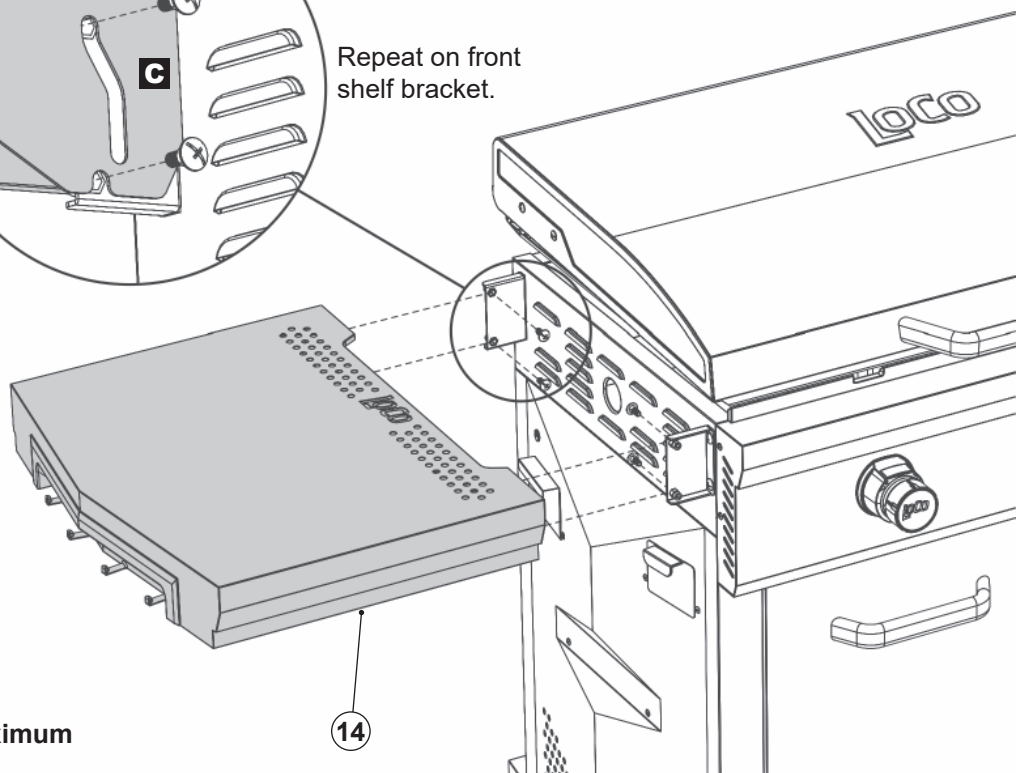

Note: Side shelves support a maximum weight of 25 lbs. (11.3 Kg)

ASSEMBLY INSTRUCTIONS

15

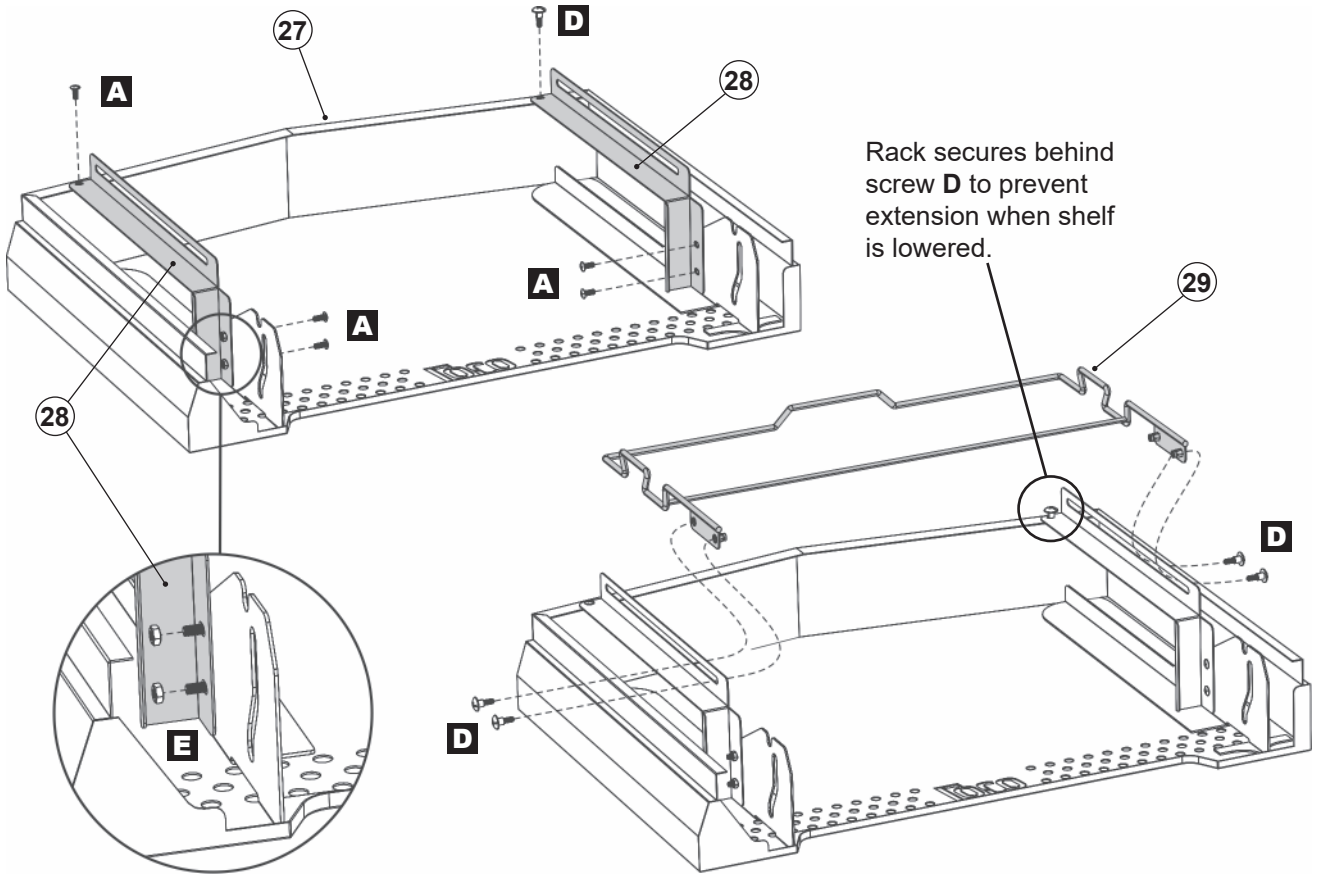
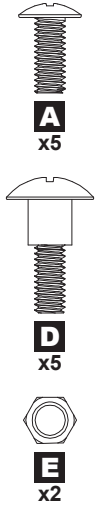

16

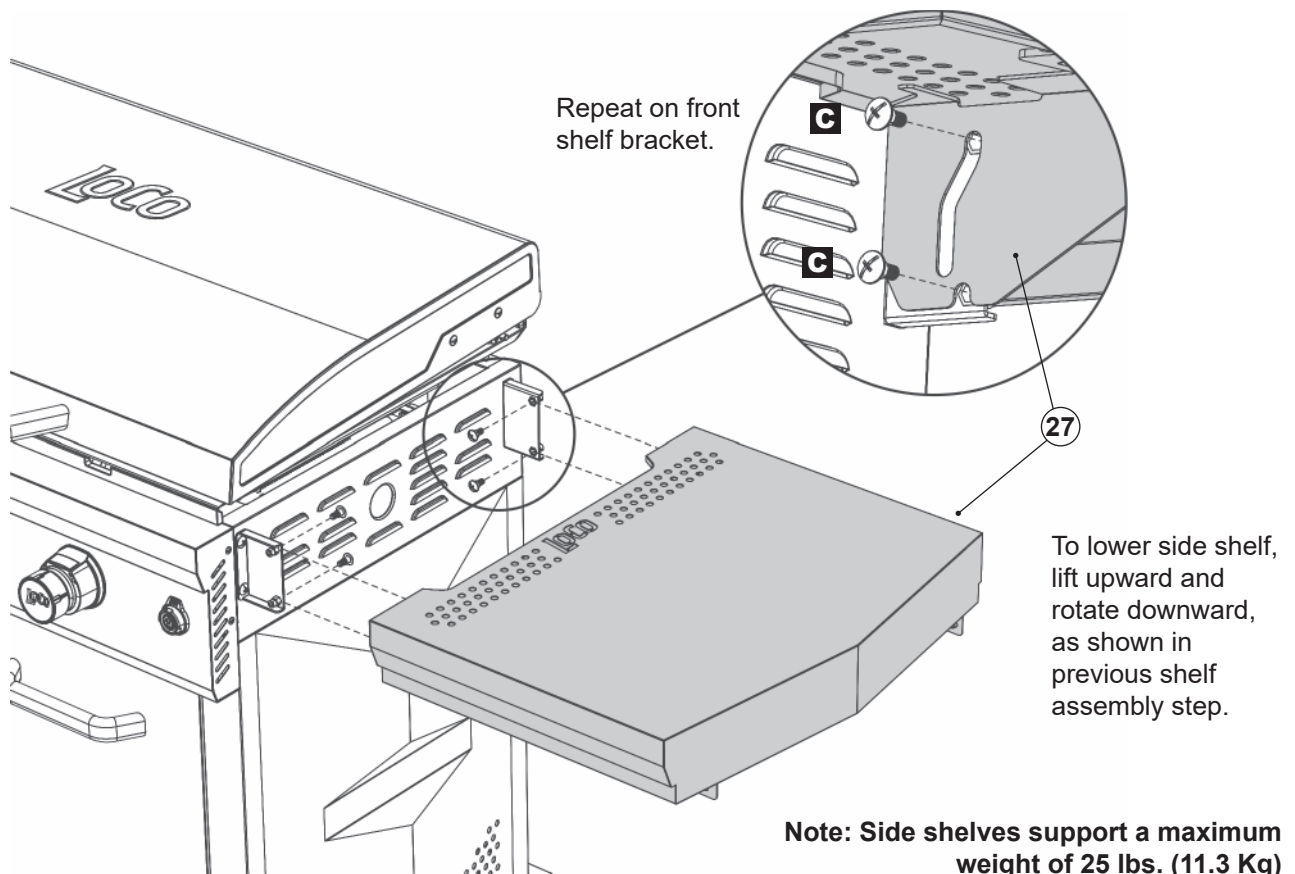
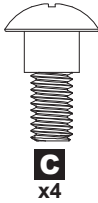

ASSEMBLY INSTRUCTIONS

17

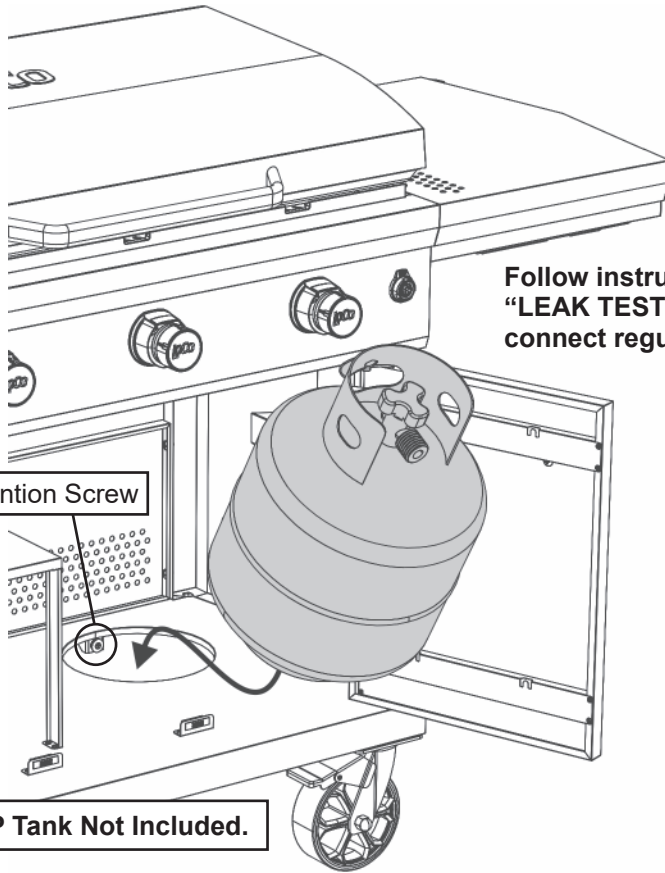

Follow instructions on the "LEAK TESTING" page to connect regulator to LP tank.

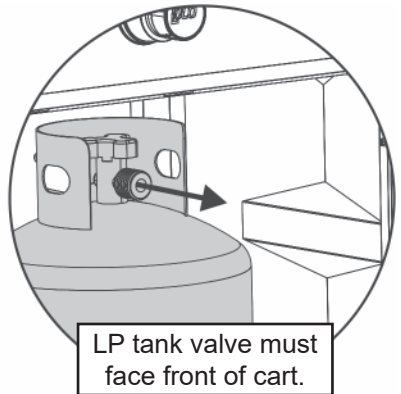

LP tank valve must face front of cart.

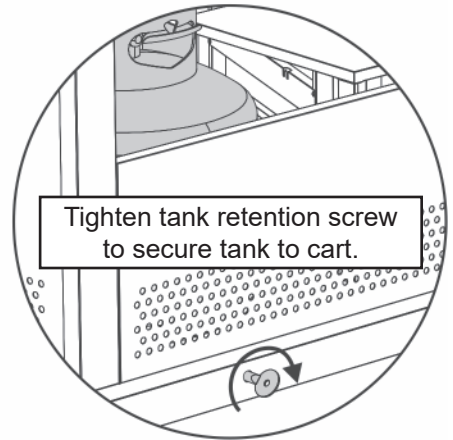

Tighten tank retention screw to secure tank to cart.

LP Tank Not Included.

18

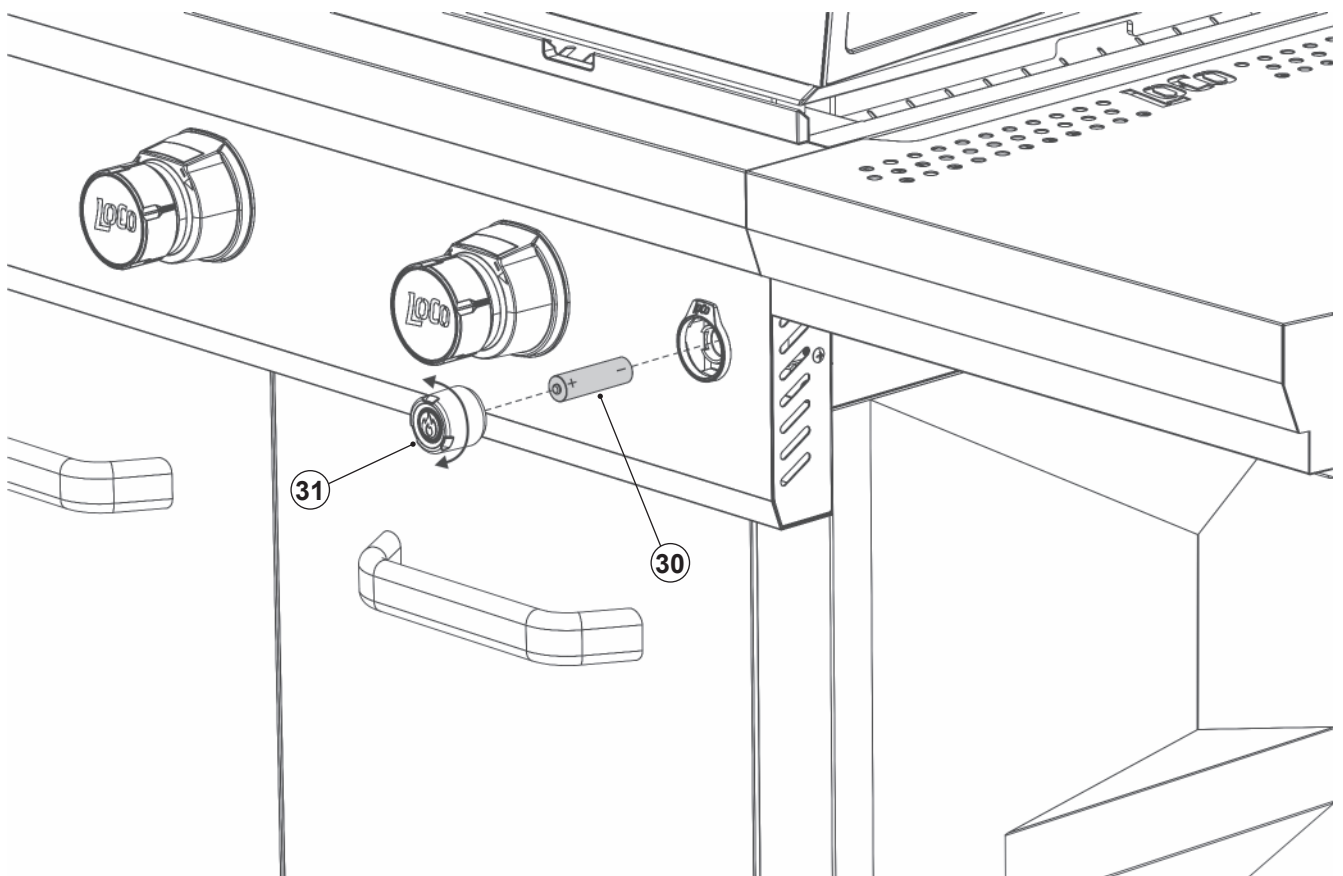

LEAK TESTING

CONNECTING REGULATOR TO LP TANK:

1. Make sure LP tank is properly secured in griddle cart.
2. Turn all control knobs to the OFF position.
3. Turn LP tank OFF by turning hand wheel clockwise to a full stop.
4. Remove the protective cap from LP tank. Always use cap and strap supplied with valve. DO NOT use a POL transport plug. It will defeat the safety feature of the valve.
5. Hold regulator, insert nipple into LP tank valve. Hand-tighten the coupling nut while holding the regulator in a straight line with LP tank valve so as not to cross-thread the connection.

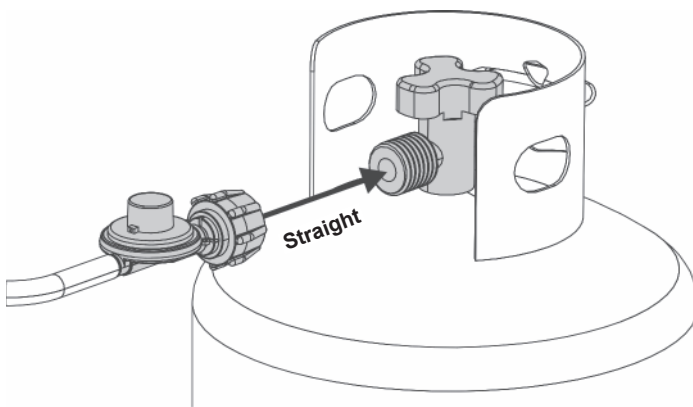
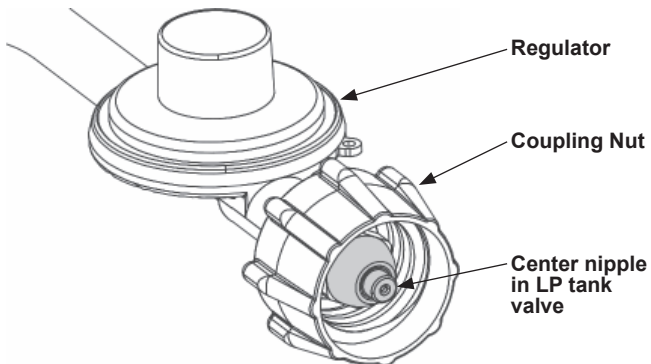

6. Turn the coupling nut clockwise and tighten to a full stop. The regulator will seal on the backcheck. An additional one-half to three-quarters turn is required to complete.

NOTE: If you cannot complete the connection, repeat steps 5 and 6. If you are still unable to complete the connection, DO NOT use this regulator.

LEAK TESTING VALVES, HOSE AND REGULATOR:

- A leak test is recommended before each use and must be repeated each time LP tank is exchanged or refilled.
- DO NOT smoke or have anything nearby that can easily ignite, such as lighters or matches.
- DO NOT use an open flame to check for gas leaks.
- Appliance must be leak tested outdoors in a well-ventilated area away from open flames or sparks.

REGULATOR HOSE ASSEMBLY CHECK:

Clean and inspect the hose before each use of the appliance. If there is evidence of abrasion, wear, cuts or leaks the hose must be replaced prior to the appliance being put into operation. The replacement hose assembly must be the one specified by the manufacturer.

LEAK TESTING

STEPS TO LEAK TEST:

1. Use a clean paintbrush and 50/50 soap and water solution. Use mild soap and water. DO NOT use household cleaning agents. Damage to gas train components could result.
2. Brush soapy solution onto all metal seams and entire valve area of LP tank. Slowly turn the LP tank valve counterclockwise to the open position. At the first sign of bubbles around the tank connection, immediately turn the valve off by turning clockwise. After 10 seconds, turn the LP tank valve to the off position and continue to watch for any bubbles. **UNDER NO CIRCUMSTANCES SHOULD THE VALVE REMAIN IN THE OPEN POSITION FOR MORE THAN 12 SECONDS.**
3. If bubbles are observed at the valve attachment, you may attempt to tighten the valve and repeat the test from the beginning after waiting 5 minutes.
4. Brush soapy solution onto **shaded areas** shown below.

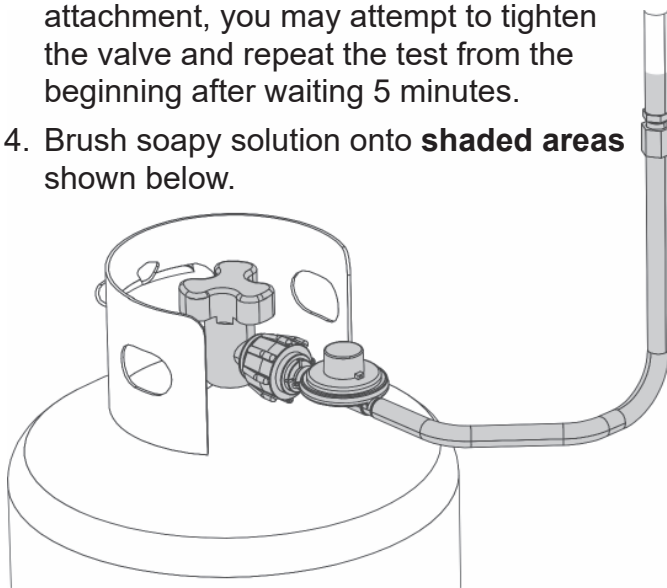

⚠️ WARNING ⚠️

If “growing” bubbles appear, there is a leak. Close LP tank valve immediately and retighten connections. If leaks cannot be stopped, do not try to repair. **IMMEDIATELY** turn off LP tank valve. If bubbles continue, **IMMEDIATELY** get away from the LP tank and contact your FIRE DEPARTMENT (911).

OPERATION

PLUGGING IN YOUR GRIDDLE:

1. Confirm that the LP tank valve is completely closed (turn clockwise to a full stop) and that all control knobs are in the OFF position as pictured, with the LoCo logo horizontal.
2. Insert the small end of the power cord into the power port on the cart's left side panel.

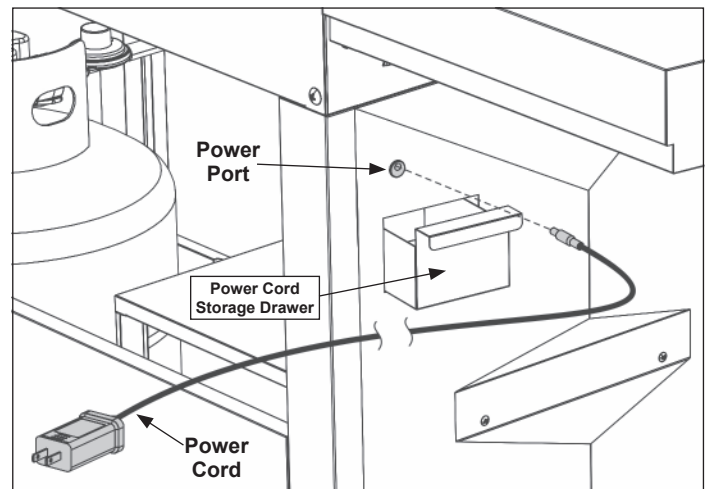

3. Plug the cord into a GFI-protected outlet. When not in use, store your power cord in the drawer near the power port.

OPERATION

LIGHTING YOUR SMARTTEMP™ PRECISION GRIDDLE:

- Read all instructions before lighting. Only light burners outdoors.
- Open lid. Side shelves must be raised/open.
- Make sure to clean and season the cooking surface. See “CARE & MAINTENANCE” section.

1. Confirm that all control knobs are in the OFF position as pictured, with the LoCo logo horizontal.



2. Open the LP tank valve fully by turning counterclockwise.



3. Push in and turn any control knob counterclockwise to Lo position.

4. SureSpark™ Ignitor Lighting:

Press and continually hold the ignition button until the burner is lit.

Repeat steps 3 and 4 to light remaining burner.

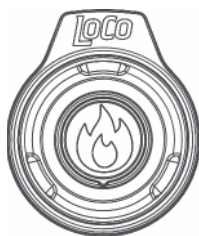

TIP: After lighting . . .

Set your desired temperature and close the lid.

The SmartTemp™ control knob display will cycle up to the set temperature.

Allow the control knob to cycle up twice before cooking.

This dual cycling to the set temperature will ensure that the cooking surface is heated evenly.

Match Lighting:

Follow lighting steps 1 and 2. The match holder is located beneath the control panel inside the cart, secured by a chain.

Push in and turn left or right control knob counterclockwise to the 275F position.

Place a match into the end of the match holder, then insert the holder with lit match into the large holes on the sides of cart to light the burners.



Match Holder

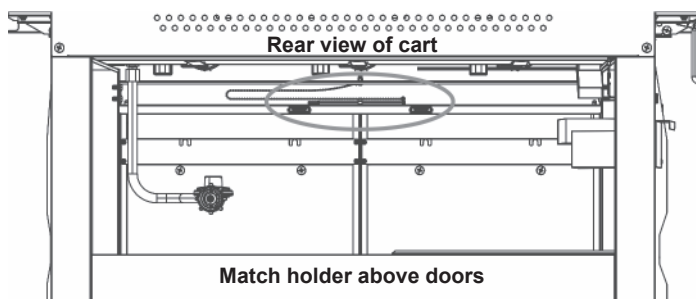

Match holder above doors

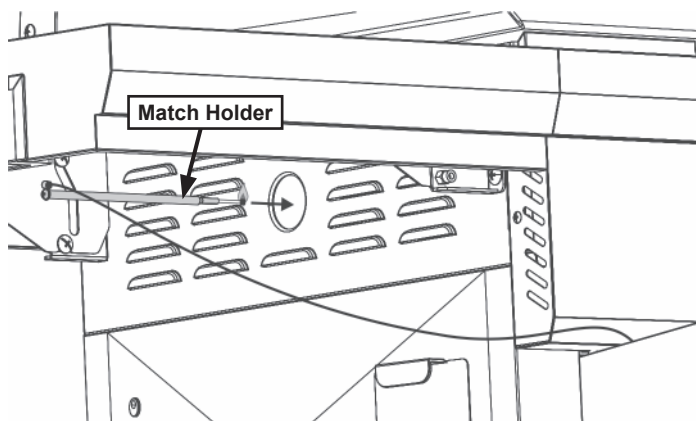

5. If ignition does not occur in 5 seconds, turn all control knobs clockwise to OFF, wait 5 minutes, then repeat the lighting procedure.
6. When the burners are lit, turn the control knobs to the desired preset cooking temperature.

Cooking Temperature Presets

**Lo • 275F • 300F • 325F • 350F • 375F
400F • 450F • SEAR**

OPERATION

FLARE-UPS/GREASE FIRES:

- Flare-ups are a common occurrence when cooking and result from a buildup of grease on the griddle surface. However, frequent flare-ups can over-cook food and can be dangerous.
- If a flare-up/grease fire occurs, turn all control knobs to the OFF position until the fire burns out. Do NOT pour water onto the flames.
- To minimize flare-ups/grease fires, trim excess fat from meat before cooking, cook high-fat meat at a lower setting and make sure your griddle is on a level surface and adjusted for proper grease drainage.

WHEN BURNER FLAME IS ACCIDENTALLY EXTINGUISHED:

1. Turn LP tank OFF by turning hand wheel clockwise to a full stop.
2. Turn all control knobs to the OFF position.
3. Inspect the hose and make sure connections are complete. After waiting 5 minutes, restart by following the lighting instructions.

SHUT DOWN INSTRUCTIONS:

1. Clean and season griddle surface for next use. See "CARE & MAINTENANCE" section.
2. Turn LP tank OFF by turning hand wheel clockwise to a full stop.
3. Turn all control knobs to the OFF position.
4. Unplug the power cord from the outlet and power port and return it to the power cord storage drawer.

DISCONNECTING REGULATOR FROM LP TANK:

1. Turn all control knobs to the OFF position.
2. Turn LP tank OFF by turning hand wheel clockwise to a full stop.
3. Make sure power cord is unplugged from outlet.
3. Turn the coupling nut counterclockwise to disconnect from LP tank. Loosen by hand only. DO NOT use tools.

 CAUTION 
The LP tank must be disconnected and removed from the cart before moving the appliance.

SPECIAL FEATURES

Three Separate Cooking Areas

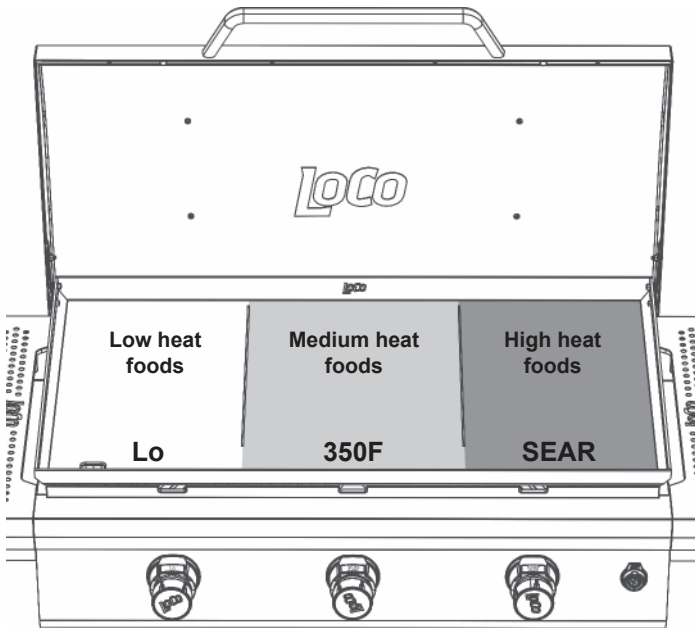

Maximum Versatility!

All three SmartTemp™ control knobs adjust from Lo to Sear with seven presets in between. Consistent temperatures for consistent results!

Integrated Grease Management

Send grease where it belongs!

Adjustable feet at each corner allow you to raise or lower the cooktop. This will help the flow of grease to it's final destination . . . the grease tray.

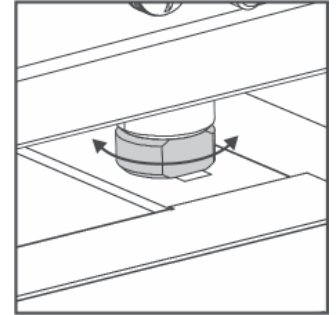
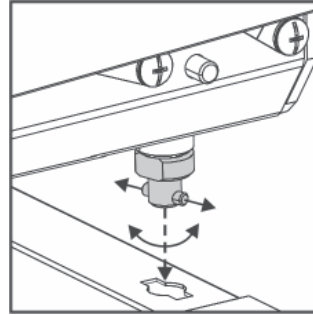
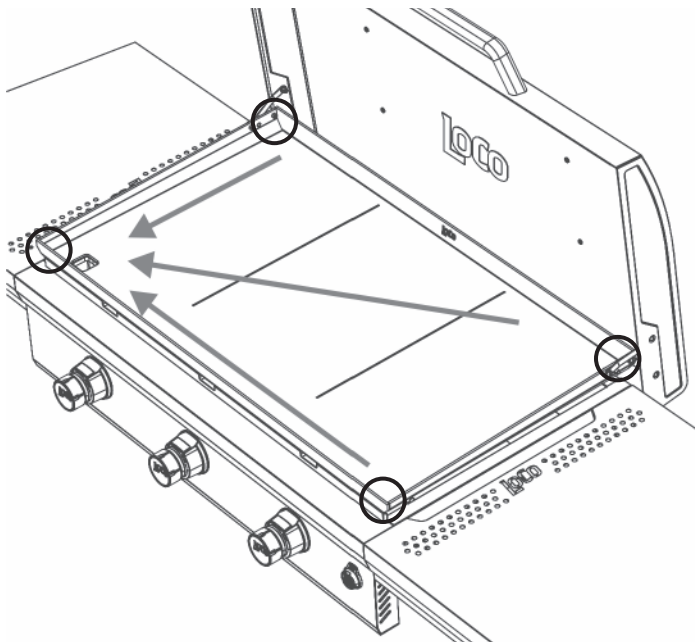

- Align posts on feet with slots in top of cart. Using included wrench, rotate feet 90° to lock cooktop to cart.
- Rotate feet, adjusting cooktop height. Test with water on the cooktop until it runs toward the drain. Dry cooktop thoroughly when adjustment is complete. Make sure cooktop remains locked to the cart. Lift cooktop to check. Rotate feet slightly more until locked.

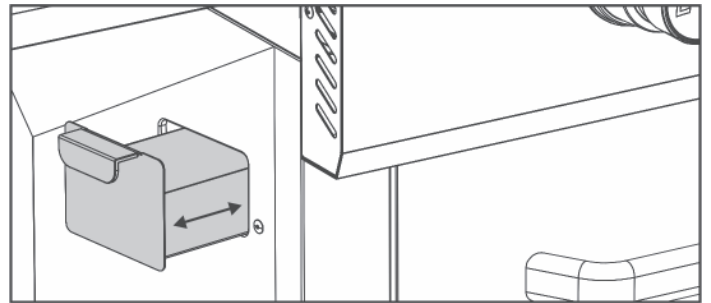

Check the grease tray periodically during heavy cooking and empty as needed. Always empty and clean grease tray after each use.

SPECIAL FEATURES

Paper Towel Rack

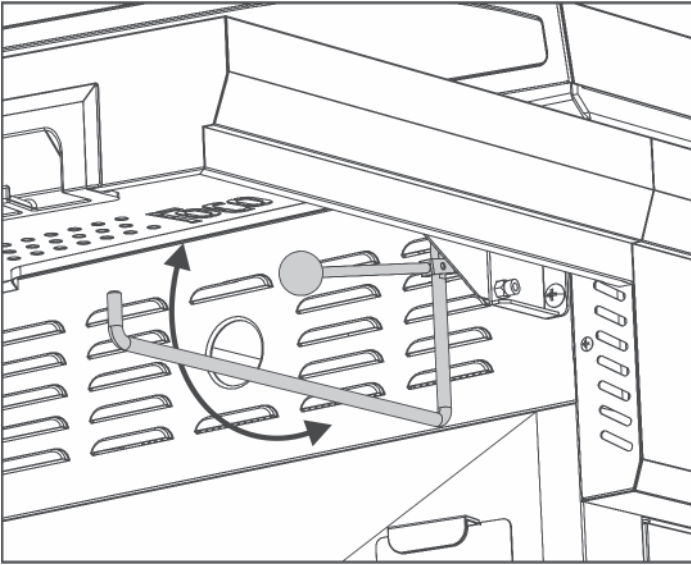

The paper towel rack, mounted beneath the left side shelf, will rotate upward and latch to the underside of the shelf, out of the way when not in use.

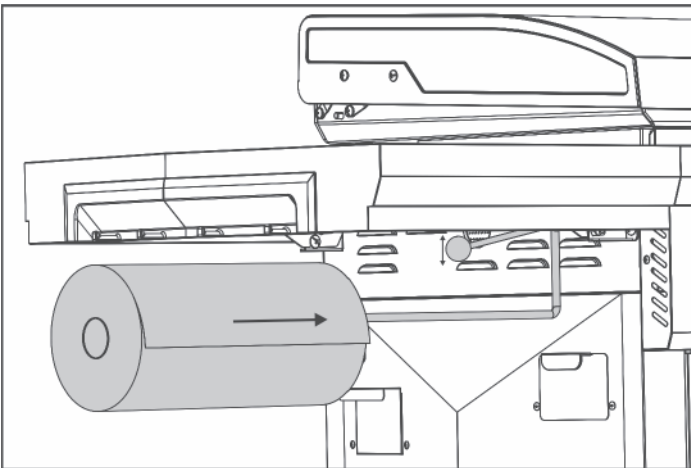

Lower the rack, lift the stabilizing lever and slide a roll of towels onto bar. The stabilizer lever will rest on the towel roll to prevent unrolling in windy conditions.

Trash Bag Rack

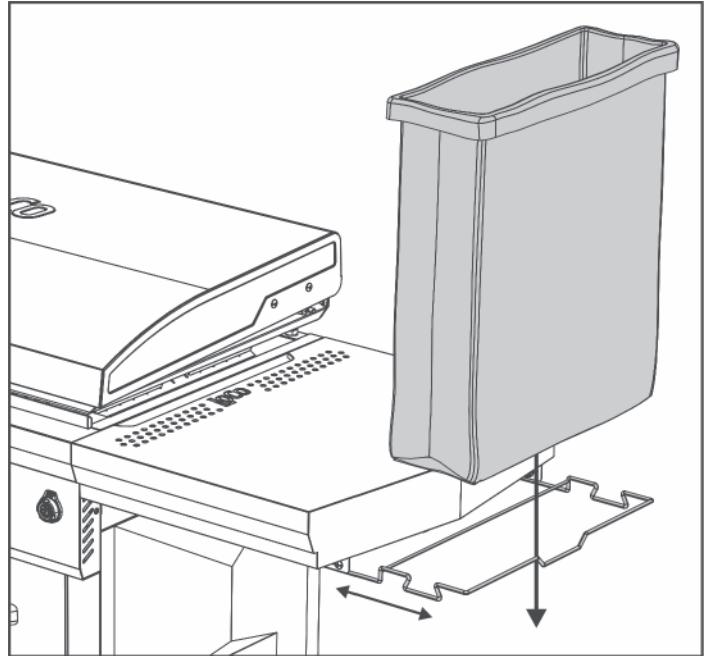

The trash bag rack, mounted beneath the right side shelf, will slide in and out of the shelf. The rack will support plastic grocery bags, kitchen trash bags or similar bags. Handy disposal within reach when preparing and during cooking.

Power Cord Storage

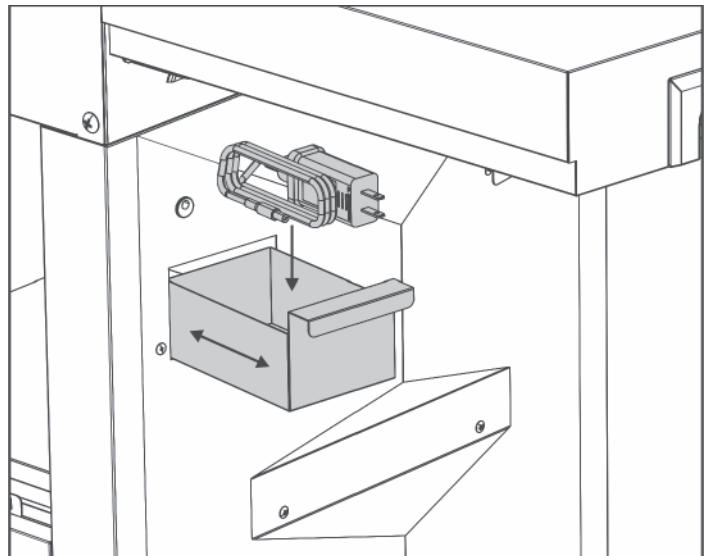

Store your power cord in the drawer on the left side of the cart when not is use. Safe from the elements.

CARE AND MAINTENANCE

SEASONING YOUR GRIDDLE:

It is important to season your griddle every time it is used.

Seasoning prepares the griddle surface for use with a coating to prevent rust and to create a permanent stick-resistant surface. Seasoning, over time and after repeated use, produces a shiny black cooking surface. As you continue to use and season your griddle surface, the more stick-resistant it will become.

Seasoning Checklist:

- Metal scraper or spatula.
- Cooking oil:
 - Vegetable, olive, peanut, canola, coconut, flax or sesame oil.
 - ***Do not use corn oil.*** The high sugar content can caramelize and damage the cooking surface.
- Paper towels
- Steel wool

Seasoning for the First Time:

1. Light griddle and turn control knobs to SEAR for approximately 15 minutes.
2. Wipe the griddle surface and the inner and outer walls with paper towels.
3. Using paper towels, rub cooking oil onto the griddle surface and the inner and outer walls.
4. Repeat these steps at least twice.

Season After Every Use:

1. Turn griddle OFF and allow it to cool until it is still slightly warm.
2. Remove as much residue as possible with a metal scraper or spatula, then wipe the griddle surface and inner and outer walls with paper towels.
3. For stubborn, stuck-on residue, relight the burners and apply cooking oil or hot water to boil the residue off. If necessary, steel wool or table salt may be used to scrub residue away. Repeat this step as necessary.
4. Wipe griddle surface and inner and outer walls again with paper towels until clean.

5. Apply an even coat of cooking oil to the griddle surface and inner and outer walls with paper towels.
6. Light burners and turn control knobs to SEAR. The oil will begin to smoke and the cooking surface will darken/discolor. Keep burning on SEAR until the smoke stops.
7. Repeat this process as necessary to re-establish a stick-resistant cooking surface.

Refurbish a Rusty Griddle Surface:

1. Light the burners and turn control knobs to SEAR for approximately 10 minutes.
2. While the griddle surface is still warm, use a metal scraper or spatula to remove as much rust as you can from the griddle surface and the inner and outer walls.
3. Apply a liberal amount of cooking oil to the griddle surface and scrub with steel wool. Continue to apply oil as needed.
4. Wipe the griddle surface and the inner and outer walls with paper towels.
5. Repeat steps 2-4 until no rust is apparent on paper towels,
6. Using paper towels, apply another even coat of cooking oil to the griddle surface and inner and outer walls.
7. Light burners and turn all control knobs to SEAR. Allow griddle to burn until cooking oil stops smoking.
8. Turn all control knobs to the OFF position and allow griddle to cool.
9. Repeat steps 6-8 until the griddle surface has a nice dark color.

Griddle owners in humid or coastal areas may need to reseason/refurbish more frequently with heavier cooking oils to keep rust and corrosion to a minimum.

CARE AND MAINTENANCE

PROPER CARE AND MAINTENANCE WILL KEEP YOUR APPLIANCE OPERATING SMOOTHLY.

CLEAN THOROUGHLY AFTER EVERY USE.

NOTE: Clean the entire appliance each year and tighten all hardware 1-2 times a year or more depending on frequency of use.

- Turn all control knobs and LP tank valve to the OFF position before cleaning.
- Check that there is no flame or gas smell.
- Make sure that the regulator is properly disconnected from the LP tank prior to any cleaning.

⚠ CAUTION ⚠

- Allow appliance to fully cool to 115°F (46°C) before performing any cleaning.
- Keep the appliance area clear and free from combustible materials, gasoline and other flammable vapors and liquids.
- Do not obstruct the flow of combustion and ventilation air.
- Keep the ventilation opening(s) of the cylinder enclosure free and clear from debris.

CART, SHELVES AND LID:

- The griddle cart and shelves can be cleaned with mild dish soap and water. For stubborn stains a citrus degreaser may be used. Rinse with water and towel or air dry.

COOKING SURFACE:

- Follow instructions under “SEASONING YOUR GRIDDLE.”
 - **Do not use dish soap.** Grease-cutting dish soaps will dissolve/degrade the stick-resistant seasoning on the griddle surface.

BURNER FLAME CHECK

Always check the flame prior to each use. Light the burners and turn control knobs to SEAR. A blue flame with little or no yellow flame will provide the best heat.

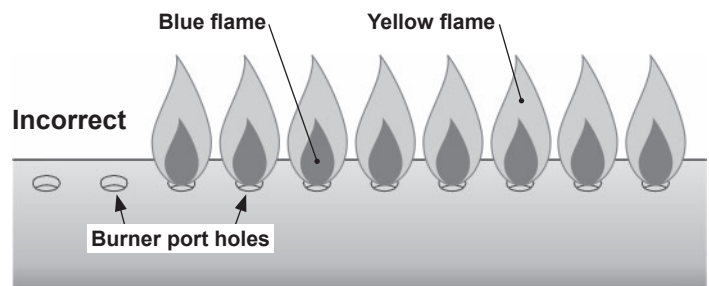
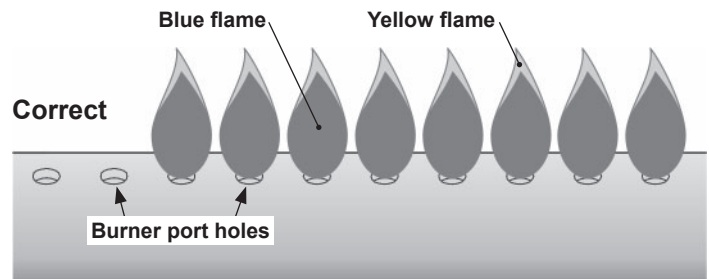

CARE AND MAINTENANCE

⚠ CAUTION ⚠

Check burner tubes for insects and insect nests. A clogged tube can obstruct the gas flow and can result in a fire beneath the appliance. Prevent blockages by inspecting and cleaning burner tubes regularly.

BURNER REMOVAL AND CLEANING:

Before removing and cleaning burners, ensure the following:

- All control knobs in OFF position and griddle is completely cool.
- LP tank valve is OFF and regulator is disconnected from tank.
- Power cord is unplugged from outlet.

NOTE: Two people required to lift and remove cooktop and lid from cart.

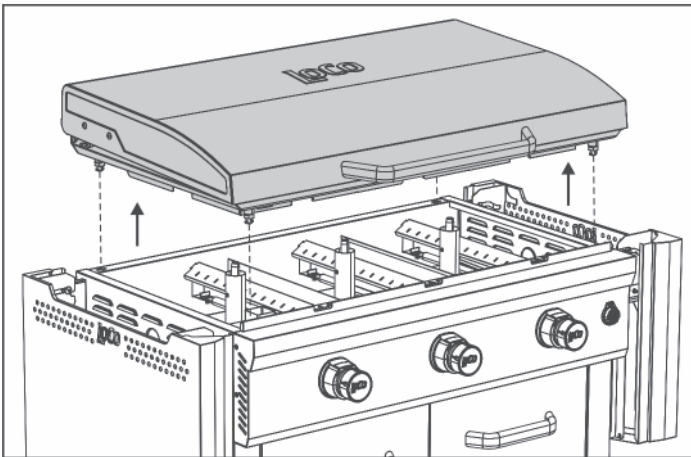

1. Rotate feet on cooktop to unlock from cart, then lift and remove cooktop and lid.

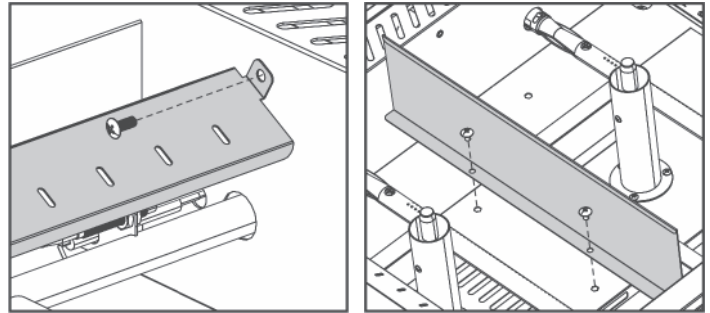

2. Remove one screw from front of burner tent. Lift burner tent from the front and remove from firebox. For easier access to burners, remove two screws from divider panel and remove panels from firebox.

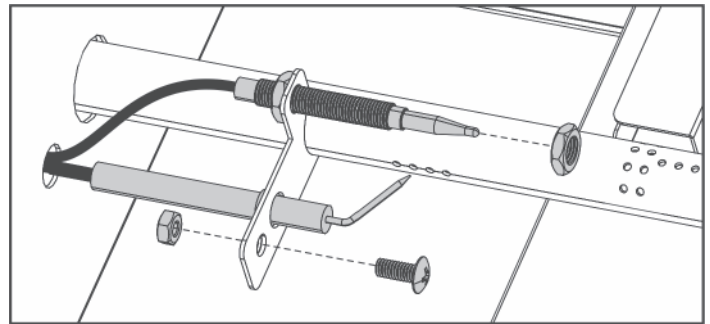

3. Remove rear hex nut from heat sensor (front hex nut remains in place). Remove screw and hex nut from electrode. Be careful not to bend electrode wire tip or crack ceramic electrode shaft.

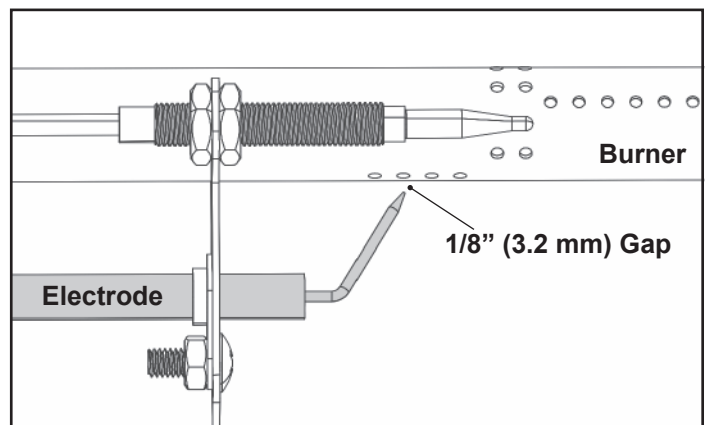

When reassembling electrode, ensure a 1/8" (3.2 mm) gap between electrode tip and burner. Electrode tip should point directly to a burner port hole.

CARE AND MAINTENANCE

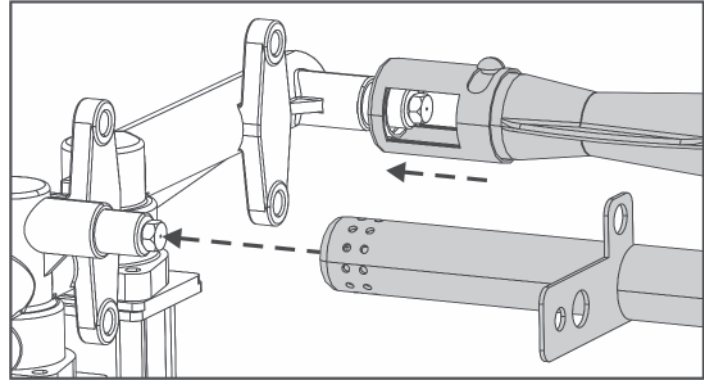
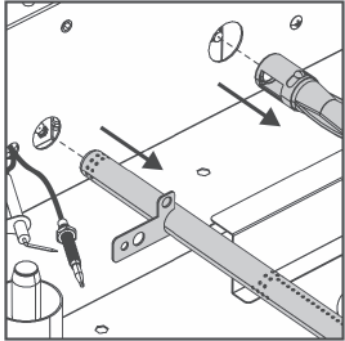
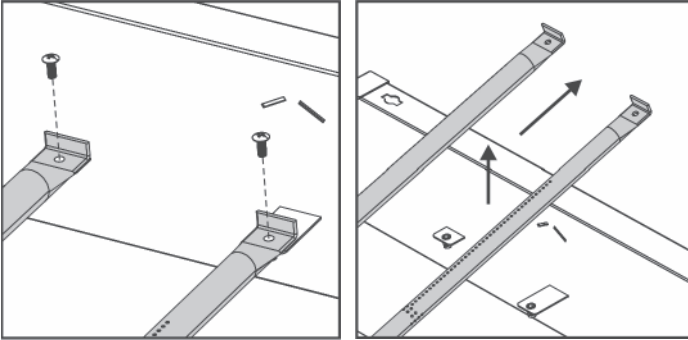

⚠ CAUTION ⚠

When the burners are reassembled, make sure to properly align burners with valve orifices. Doing this is critical for maximum performance and efficiency.

4. Remove one screw from the back of each burner. Lift back of burners upward and to the rear of the firebox, sliding burners away from valves. Carefully remove heat sensor and electrode from burner bracket.
5. Check burners for cracks or large holes. If burners are damaged contact customer service for replacement.

Scrub all residue and dirt from outer surface of burners.

Clean/open clogged port holes with a stiff wire, such as an opened paper clip.

Clean inside of burner tube with compressed air or a garden hose with high-pressure nozzle. Allow burner to dry completely.

6. Follow steps in reverse order to reassemble burners in firebox.

STORING YOUR GRIDDLE:

- Ensure that all control knobs and the LP tank valve are in the OFF position.
- Disconnect the regulator from the LP tank valve.
- Clean and dry all surfaces.
- Coating the burners lightly with cooking oil will prevent excess rust.
- Season the griddle surface.
- If the griddle is to be stored indoors, remove the LP tank from the cart and store the tank outdoors in a well-ventilated area away from direct sunlight. Cover the griddle and store in a cool dry place.
- If the griddle is to be stored outdoors, use a griddle cover for protection from the elements.

TROUBLESHOOTING

PROBLEM	POSSIBLE CAUSE	SOLUTION
Burner will not light using ignitor.	LP tank valve is closed.	Make sure the regulator is properly attached to the LP tank. Turn LP tank valve counterclockwise to open.
	Bad connection between the regulator and LP tank.	Make sure the regulator coupling nut is fully tightened on the LP tank valve.
	The LP tank is empty.	Refill LP tank at an authorized dealer, exchange or purchase new filled LP tank.
	Battery not installed correctly.	Make sure the + and – ends of the battery are oriented properly. The + end should be toward the ignitor button.
	Weak or dead battery.	Replace with new alkaline AA battery.
	Ignitor button not installed correctly.	Unscrew ignitor button and reinstall. Make sure threads are aligned and engaged fully.
	Wires or electrode covered in cooking residue.	Clean wire and/or electrode with rubbing alcohol.
	Electrode and burners are wet.	Wipe dry with clean cloth.
	Electrode cracked or broken - sparks at crack.	Contact customer service for replacement parts.
	Ignitor malfunctioning.	Contact customer service for replacement parts.
Burner will not light with a match.	LP tank valve is closed.	Make sure the regulator is properly attached to the LP tank. Turn LP tank valve counterclockwise to open.
	Bad connection between the regulator and LP tank.	Make sure the regulator coupling nut is fully tightened on the LP tank valve.
	The LP tank is empty.	Refill LP tank at an authorized dealer, exchange or purchase new filled LP tank.
	Obstruction of gas flow.	Clean burner tubes and check for bent or kinked gas hose.
	Disengagement of burner to valve.	Re-engage burner and valve.
	Burner ports clogged or blocked.	Clean burner ports.
Irregular flame pattern. Flame does not run the full length of the burner.	Burner ports are clogged or blocked.	Clean burner ports.

TROUBLESHOOTING

PROBLEM	POSSIBLE CAUSE	SOLUTION
Sudden drop in gas flow or reduced flame height.	The LP tank is empty.	Refill LP tank at an authorized dealer, exchange or purchase new filled LP tank.
	Overfill Protection Device (OPD) on LP tank has been activated/tripped.	Turn control knobs to OFF, wait 30 seconds, then relight griddle. If flames are still too low, reset the Overfill Protection Device. Turn all control knobs and the LP tank valve OFF. Disconnect the regulator from the LP tank and wait at least one minute. Reconnect the regulator to the LP tank and fully open LP tank valve.
Flame is yellow or orange.	New burner may have residual manufacturing oils.	Light griddle and burn on SEAR for 15 minutes.
	Obstruction of gas flow.	Clean burner tubes and check for bent or kinked gas hose.
	Grease or food residue on burner.	Clean burner.
	Poor alignment or disengagement of burner to valve.	Align/re-engage burner and valve.
Flames go out.	High or gusting winds.	Do not use griddle in high winds.
	The LP tank is empty.	Refill LP tank at an authorized dealer, exchange or purchase new filled LP tank.
	Overfill Protection Device (OPD) on LP tank has been activated/tripped.	Refer to "Sudden drop in gas flow or reduced flame height" above.
Persistent grease fire.	Grease trapped by food buildup around burner system.	Turn all control knobs and LP gas tank valve to OFF. Allow grease fire to burn out and griddle to cool. Clean all parts of excess grease and food buildup.
Flare-up.	Grease buildup.	Clean all parts of excess grease.
	Excess fat in meat.	Trim excess fat from meat before cooking.
	Cooking temperature too high.	Adjust to lower temperature.
Flashback (fire in burner tube).	Burner tube blocked.	Clean burner tube.
Griddle surface.	Surface has started to rust.	Rust on the griddle surface is normal with use. Follow instructions in this manual to refurbish/season griddle surface.
	Griddle surface is dull.	The griddle surface has gotten too hot and is no longer seasoned. Follow instructions in this manual to refurbish/season griddle surface.

TROUBLESHOOTING

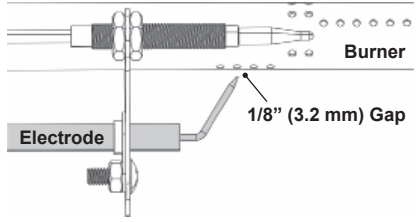
PROBLEM	POSSIBLE CAUSE	SOLUTION
Excess grease collects on griddle surface while cooking.	Cooktop not adjusted for grease drainage.	Using included wrench, rotate cooktop feet to raise or lower cooktop until grease flows toward drain.
Error Code ErrF	<ol style="list-style-type: none"> 1. Empty propane cylinder. 2. Too much time passed after valve was turned on before flame sensor was activated. 3. Flame sensor failure or failure of flame sensor to detect flame. 4. First time lighting the griddle after connecting propane tank. 5. Tip of electrode out of position. 6. Ignitor malfunction. 7. Ignitor wire pinched or arcing behind control panel. 	<ol style="list-style-type: none"> 1. Check fuel level in cylinder. 2. Wait 5 minutes for fuel to dissipate then retry ignition. 3. Check flame sensor for carbon buildup. 4. Check that the flame sensor is in contact with the pilot flame. 5. Ensure a 1/8" (3.2 mm) gap between electrode tip and burner. Electrode tip should point directly to a burner port hole. <div style="text-align: center; margin-top: 10px;">  <p>The diagram illustrates the required clearance between the electrode and the burner. It shows a side view of the burner assembly with an electrode positioned below it. A dimension line indicates a 1/8" (3.2 mm) gap between the tip of the electrode and the burner's port hole. Labels 'Electrode' and 'Burner' are included for identification.</p> </div> 6. Contact Customer Service. 7. Contact Customer Service.
Error Code Err1	Temperature sensor is disconnected.	<ol style="list-style-type: none"> 1. Check the temperature sensor and its wiring for damage. 2. Make sure the temperature sensor is securely attached to the controller. 3. Contact Customer Service.
Error Code Err2	Temperature sensor is shorted electrically.	<ol style="list-style-type: none"> 1. Inspect temperature sensor wiring for areas where the insulation may be cut or pinched between metal components. 2. Contact Customer Service.
Error Code Err3	Solenoid valve 1 non-functional.	Contact Customer Service.
Error Code Err4	Solenoid valve 2 non-functional.	Contact Customer Service.

WARRANTY INFORMATION

The appliance has been manufactured under the highest standards of quality and workmanship. We warrant to the original consumer/purchaser that all aspects of this product will be free of defects in material and workmanship for one (1) year from the date of purchase. A replacement for any defective part will be supplied free of charge for installation by the consumer. Requests for expedited shipments of warranted parts will be at the consumer's/purchaser's expense. Defects or damage caused by the use of other than genuine parts are not covered by this warranty. This warranty shall be effective from the date of purchase as shown on the purchaser's receipt.

This warranty is valid for the original consumer/purchaser only and excludes industrial, commercial or business use of the product, product damage due to shipment or failure which results from alteration, product abuse or product misuse whether performed by a contractor, service company or consumer. We will not be responsible for labor charges and/or damage incurred in installation, repair or replacement, nor for incidental or consequential damage.

Model Number: LCG3ST3C36



This device complies with part 15 of the FCC Rules. Operation is subject to the following two conditions:

- (1) This device may not cause harmful interference, and
- (2) this device must accept any interference received, including interference that may cause undesired operation.

Warning: Changes or modifications to this unit not expressly approved by the party responsible for compliance could void the user's authority to operate the equipment.

Note: This equipment has been tested and found to comply with the limits for a Class B digital device, pursuant to part 15 of the FCC Rules. These limits are designed to provide reasonable protection against harmful interference in a residential installation. This equipment generates, uses and can radiate radio frequency energy and, if not installed and used in accordance with the instructions, may cause harmful interference to radio communications. However, there is no guarantee that interference will not occur in a particular installation. If this equipment does cause harmful interference to radio or television reception, which can be determined by turning the equipment off and on, the user is encouraged to try to correct the interference by one or more of the following measures:

- Reorient or relocate the receiving antenna.
- Increase the separation between the equipment and receiver.
- Connect the equipment into an outlet on a circuit different from that to which the receiver is connected.
- Consult the dealer or an experienced radio/TV technician for help.

Importer: LOCO-CRAZY GOOD COOKERS, LLC

Address: 506 Manchester Expressway, Suite A2, Columbus, GA 31904

Telephone Number: 800-391-0436



LoCo - Crazy Good Cookers, LLC.

506 Manchester Expressway • Suite A2 • Columbus, Georgia 31904
800-391-0436 • Email: customerservice@lococookers.com



**Connect with us @lococookers • lococookers.com
#whatchagriddlin**

Made in China