

Temperature Gauge Overview

Overheating can permanently damage your engine and transmission/gearbox. Monitor and provide early warning of overheating with a visual and audible temperature alarm you can set.

Why do you need a gauge to display and alarm engine and transmission temperatures?

Standard temperature indicators sometimes provide engine temperature information. But if you're focused on driving, you may miss the indicator going into the **RED** until it is too late and your engine or transmission is damaged.

Often standard indicators only measure the engine coolant water temperature. If your engine water is lost or the level drops for any reason, many indicators won't show that the engine is overheating. You may not be aware that your engine is being damaged.

Most vehicles do not have an indicator showing transmission temperature. If you are 4WD'ing or towing a caravan, boat, trailer etc, your transmission and engine will be working hard, increasing the temperature. The temperature of the transmission can also become excessive during high speed highway driving. If you are not aware of your actual transmission temperature, you have no way of knowing whether it is being damaged by excessive heating.

This gauge allows you to monitor and set alarms for both the engine block and transmission housing temperatures during all driving conditions. The temperature gauge uses digital technology and has a full colour screen to display temperatures, settings and alarms. The display and settings can be in Celsius or Fahrenheit (option).

You can set **SAFE** engine and transmission temperature levels which the display will show in **GREEN**. By setting the **MAXIMUM** temperature levels, an audible alarm and flashing **RED** display will be triggered if the maximum temperature is exceeded. If the temperature is above **SAFE** but below the **MAXIMUM**, the display will show an **AMBER** warning. If the engine or transmission temperatures are below freezing, the gauge display will show **BLUE**. The gauge can also show the highest engine and transmission temperatures reached since the gauge was powered on.

The gauge is designed to mount on the vehicle dash or similar surface. The outside dimensions are 60mm width, 52mm height, 20mm depth.

There are two gauge buttons - **Menu** and **Settings**. The steps required to set the temperature alarms, adjust the screen brightness etc are easy to follow.



Simulated gauge display showing both engine and transmission temperatures are safe.
Highest temperatures have also been safe.

Simulated Gauge Displays



Normal Safe Level



Warning Level



Alarm Flashing and Audible

Note: Values in the above displays can be set to your preferences

How it Works

The gauge receives continuous engine and transmission temperature measurements from two digital temperature sensors mounted directly on the engine block and transmission housing.

Each digital temperature sensor can measure temperatures from -55°C to +125°C (-67°F to +257°F). The gauge displays temperatures in one degree increments.

The gauge checks the measured temperature against two temperature levels (SAFE and MAXIMUM) which are set separately for the engine and transmission.

- SAFE temperature. An engine (or transmission) temperature at or below SAFE is normal operation.
- MAXIMUM temperature. An engine (or transmission) temperature at or above the MAXIMUM will flash a **RED** display and trigger the audible alarm. The alarm will also be triggered if the gauge cannot receive a temperature reading from either sensor.

The SAFE temperature setting must be lower than the MAXIMUM temperature setting. An engine or transmission temperature in the range between SAFE and MAXIMUM is displayed as a warning in **AMBER**. By pressing the Settings button, the gauge will display the highest engine and transmission temperatures reached since the gauge was powered on.

For example, in the 3 simulated gauge displays above, the SAFE level is 90°C and the MAXIMUM level is 100°C. The warning range is 91°C to 99°C.

The gauge display icons, settings and colours used are clear and easy to understand. One glance at the gauge and, if the display is **GREEN**, all is normal.

Options

- Celsius and Fahrenheit temperature standards are supported. Please nominate the standard you require when ordering or follow the instructions to change the standard.
- Two waterproof digital temperature sensors marked engine and transmission (blue stripe on the sensor) are supplied with the gauge. If you do not want to install the transmission sensor, you can set the gauge to display only the engine temperature. This is done by leaving the transmission sensor disconnected inside the junction box and restoring the gauge to factory settings once (refer to the Menu and Settings Summary). If you install the transmission sensor later, restore the gauge to factory settings again and the gauge will display both engine and transmission temperatures.
- Replacement sensors or sensors with longer cables are also available by emailing gauge.innovations@gmail.com.

The gauge has been designed, developed, manufactured and extensively road tested in Australia. It is backed by a 12 month, return to manufacturer warranty against manufacturing defects.

As further enhancements become available, wherever practicable, gauge owners will be offered an option to upgrade.

The firmware, icons etc can also be modified to suit particular requirements. If you have a special requirement or a suggestion for improvement, contact us by email at gauge.innovations@gmail.com.

Installation

What's in the box

- Temperature Gauge, dash mounted 60mm width, 52mm height, 20mm depth.
- Gauge junction box to connect 12v DC power (to mount under the dash).
- Power connector plug and cable 12v DC. Red is positive, Black is negative chassis ground.
- Two waterproof digital temperature sensors including cables and connectors. Engine sensor (1 meter cable). Transmission sensor (2 meter cable marked with a blue strip).
- Sensor junction box to mount under the vehicle bonnet.
- A cable (2.5 meters) with a plug at each end to connect the gauge junction box to the sensor junction box (normally through the firewall) 4 pin plug is at the gauge junction box end, 3 pin plug at the sensor junction box end.
- Mounting hardware, double sided adhesive pads, cable ties etc.

Gauge installation is straightforward. Only three connections are required:

- One 5 pin plug from the gauge to the gauge junction box
- One 2 pin plug for power to the gauge junction box (2 wire, positive and negative)
- One 4 pin plug from gauge junction box to the temperature sensor junction box (single cable to run through the firewall)

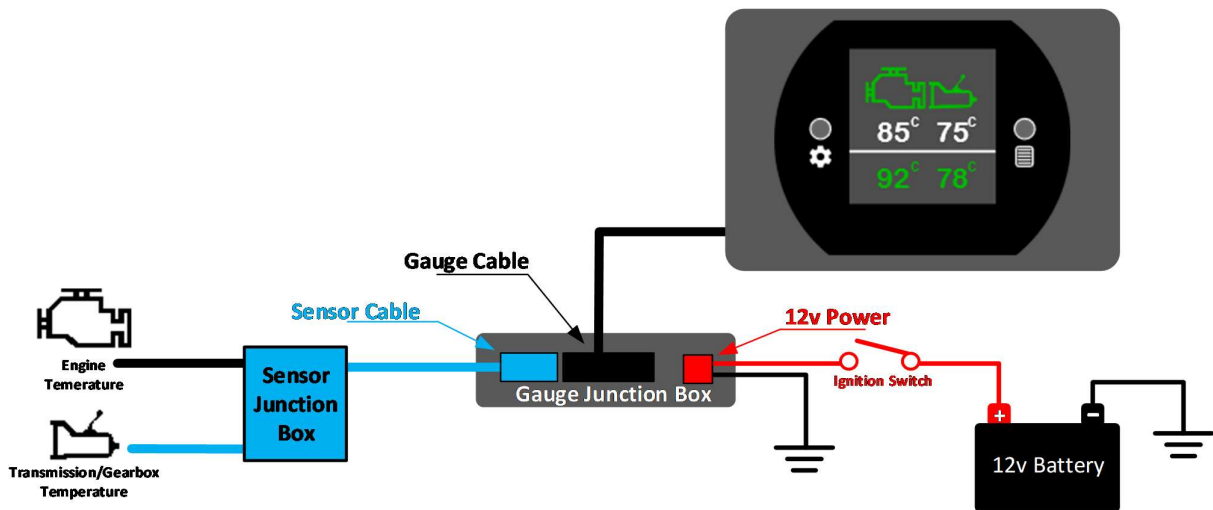

Wiring Diagram (gauge rear view)

The gauge requires 12 volts DC to operate. This should be from a switched power source that is activated by the ignition key. The gauge requires less than 25ma current during normal operation.

For best viewing, avoid installing the gauge where it will often be in direct sunlight.

The cable from the "under the dash" connection box to the sensors will need to be run to the central junction box located under the bonnet. Normally this will be through the firewall. Loop and secure any excess cable length.

The junction box under the bonnet is secured in a convenient location where the sensor cables can be connected.

In the case of 4WD vehicles, the junction box should be located where it will not be submerged if driving through water. Alternatively, the junction box and cable entry points can be sealed using silicone or similar material.

The temperature sensors are mounted using an existing M8 bolt located on the engine block and transmission housing where the temperature will be measured. It is important that a mounting point bolt for each sensor is used which:

- Will provide reliable measurement of the engine block or transmission housing temperature.
- Is well away from any other sources of heat such as exhausts, turbos etc.
- Is protected from mechanical damage to the sensor or its cable
- Is well away from sources of excessive electrical noise (eg spark plugs, distributor and two-way radios)

NOTE: You should not swap the engine and transmission sensors. If you do, the engine and transmission temperature display will be reversed.

NOTE: There is an electronic "fuse" in the "under the dash" connector box. If, in the unlikely event there is excess 12v current, the electronic fuse will limit the current. The "fuse" will reset automatically when the excess current is removed.

Temperature Gauge Menu and Settings Summary







Menu button cycles through the gauge settings screens.



Settings button increases a setting. Press and hold to rapidly increase a setting. The setting value will only increase until it reaches the maximum value and then loop back to the lowest value where it will begin to increase with every press of the button.

Press the Menu or Settings button to silence an audible alarm.

	<p>1) SET THE HIGHEST SAFE ENGINE TEMPERATURE</p> <p>Press and release the Menu button.</p> <p>Press the Settings button to adjust the highest SAFE engine temperature. Range 0°C to 125°C (257°F).</p>
	<p>2) SET ENGINE MAXIMUM ALARM TEMPERATURE</p> <p>Press and release the Menu button again.</p> <p>Press the Settings button to adjust the engine MAXIMUM alarm temperature. The range will be from SAFE to 125°C (257°F).</p>
	<p>3) SET HIGHEST SAFE TRANSMISSION TEMPERATURE</p> <p>Press and release the Menu button again.</p> <p>Press the Settings button to adjust the highest SAFE transmission temperature. Range 0°C to 125°C (257°F).</p>
	<p>4) SET TRANSMISSION MAXIMUM ALARM TEMPERATURE</p> <p>Press and release the Menu button again.</p> <p>Press the Settings button to adjust the transmission MAXIMUM alarm temperature. The range will be from SAFE to 125°C (257°F).</p>

	<p>5) SET SCREEN BRIGHTNESS</p> <p>Press and release the Menu button again.</p> <p>Press the Settings button to adjust the screen brightness.</p>
	<p>6) TURN AUDIBLE ALARM ON/OFF</p> <p>Press and release Menu button again.</p> <p>Press the Settings button to turn the audible alarm on or off.</p> <p>NOTE: If the audible alarm is turned off, there will be no audible warning of engine or transmission temperature alarms. Please remember to keep the audible alarm setting on whenever you drive.</p>
	<p>6) SAVE SETTINGS AND RETURN TO MONITORING MODE</p> <p>Press and release the Menu button again.</p> <p>The gauge will also revert to the normal monitoring mode after approximately 30 seconds of no Menu or Settings button activity.</p>
	<p>7) DISPLAY HIGHEST ENGINE AND TRANSMISSION TEMPERATURES</p> <p>Press the Settings button while the gauge is in monitoring mode to toggle off/on the display of the highest engine and transmission temperatures reached since the gauge was powered on. The display is colour coded safe, warning or maximum.</p> <p>It can be useful to check the highest temperatures reached during normal operation as a guide to setting the SAFE and MAXIMUM levels.</p>



To restore the gauge to factory default settings - Press and hold the Settings button while the gauge is being powered on.



To toggle between Celsius and Fahrenheit temperature standards and restore the gauge to factory default settings hold down both the Menu and the Settings buttons while the gauge is being powered on.