

Temperature and Coolant Level Gauge Overview

Overheating can permanently damage your engine. Monitor coolant level and provide early warning of engine overheating with a visual and audible temperature alarm you can set.

What are the benefits of a gauge to display and alarm engine temperature? Why should the engine coolant level be monitored and alarmed?

Standard temperature indicators sometimes provide engine temperature information. But if you're focused on driving, you may miss the indicator going into the **RED** until it is too late and your engine is damaged.

Often standard indicators only measure the engine coolant water temperature. If your engine coolant is lost or the level drops for any reason, many indicators won't show that the engine is overheating. You may not be aware that your engine is being damaged.

Low coolant level or loss of coolant is often the cause of engine overheating. Yet many vehicles do not have an indicator to monitor the coolant level or any alarm.

This gauge allows you to monitor and set alarms for the engine block temperature during all driving conditions. The gauge also includes a sensor which monitors the engine coolant level and provides both a visual and audible alarm if the coolant level is low.

The gauge uses digital technology and has a full colour screen to display temperature, coolant level, settings and alarms. The temperature display and settings can be in Celsius or Fahrenheit (option).

The coolant level sensor uses smart technology to monitor the coolant level. There is no need to drill holes in the coolant bottle or put anything in the bottle. The sensor attaches to the outside of the coolant bottle at the level you decide. Your coolant bottle will not be damaged and your vehicle warranty can not be affected. But for the sensor to work properly, your coolant bottle **MUST** be plastic. The sensor will not work on metal coolant tanks.

You can set the **SAFE** engine temperature level which the display will show in **GREEN**. By setting the **MAXIMUM** temperature level, an audible alarm and flashing **RED** display will be triggered if the maximum temperature is exceeded. If the temperature is above **SAFE** but below the **MAXIMUM**, the display will show an **AMBER** warning. If the engine temperatures are below freezing, the gauge display will show **BLUE**. The gauge can also show the highest engine temperature reached since the gauge was powered on.

Engine coolant level is displayed as **GREEN** if the level is ok or **RED** if the level is low. A visual and audible alarm is triggered if the coolant level is low.

The gauge is designed to mount on the vehicle dash or similar surface. The outside dimensions are 60mm width, 52mm height, 19mm depth.

There are two gauge buttons - **Menu** and **Settings**. The steps required to set the temperature alarms, adjust the screen brightness etc are easy to follow.



Settings Button 

 Menu button

Simulated gauge display showing the engine temperatures is safe.
The engine coolant level is ok.

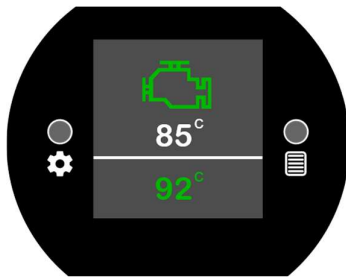

Press the Settings Button to show the highest engine temperature reached since the gauge was powered on.

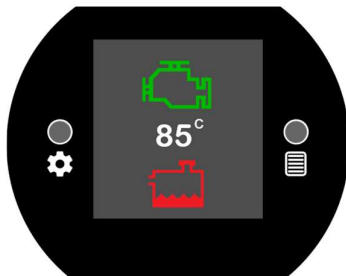

Simulated display showing Engine Coolant is low (flashing and audible alarm)

Simulated Gauge Displays



Normal Safe Level
Coolant Level Ok



Warning Level
Coolant Level Ok



Alarm Flashing and Audible
Low Coolant

Note: Values in the above displays can be set to your preferences

How it Works

Engine Block Temperature

The gauge receives continuous engine temperature measurements from a digital temperature sensor mounted directly on the engine block.

The digital temperature sensor can measure temperatures from -55°C to +125°C (-67°F to +257°F). The gauge displays temperatures in one degree increments.

The gauge checks the measured temperature against two temperature levels (SAFE and MAXIMUM) which are set for the engine.

- SAFE temperature. An engine temperature at or below SAFE is normal operation.
- MAXIMUM temperature. An engine temperature at or above the MAXIMUM will flash a **RED** display and trigger the audible alarm. The alarm will also be triggered if the gauge cannot receive a temperature reading from the sensor.

The SAFE temperature setting must be lower than the MAXIMUM temperature setting. An engine temperature in the range between SAFE and MAXIMUM is displayed as a warning in **AMBER**. By pressing the Settings button, the gauge will display the highest engine temperatures reached since the gauge was powered on.

For example, in the 3 simulated gauge displays above, the SAFE level is 90°C and the MAXIMUM level is 100°C. The warning range is 91°C to 99°C.

The gauge display icons, settings and colours used are clear and easy to understand. One glance at the gauge and, if the display is **GREEN**, all is normal.

Options

- Celsius and Fahrenheit temperature standards are supported. Please nominate the standard you require when ordering or email gauge.innovations@gmail.com for advice on how to change standard.
- One waterproof digital temperature sensor is supplied with the gauge.
- Replacement engine sensors or sensors with longer cables are also available by emailing gauge.innovations@gmail.com.

Engine Coolant Level Monitoring

The coolant sensor attaches to the outside of the plastic coolant bottle at the level you decide. The sensor technology detects if there is coolant inside the bottle up to that level or not. The gauge checks the sensor and triggers both a visual and audible alarm if the sensor detects there is no coolant. There is also a red light indicator on the sensor which shows whether the sensor has detected the coolant. Smart technology in the gauge minimises false alarms if the coolant is sloshing in the bottle.

PLEASE NOTE: For the coolant level sensor to work properly your coolant bottle **MUST** be plastic. The sensor will not work on metal coolant tanks.

If you do not want to install the coolant sensor, you can set the gauge to display only the engine temperature. This is done by leaving the coolant sensor disconnected inside the junction box and restoring the gauge to factory settings once (refer to the Menu and Settings Summary). If you install the coolant sensor later, restore the gauge to factory settings again and the gauge will display engine temperature and coolant level.

Warranty and Enhancements

The gauge has been designed, developed, manufactured and extensively road tested in Australia. It is backed by a 12 month, return to manufacturer warranty against manufacturing defects.

As further enhancements become available, wherever practicable, gauge owners will be offered an option to upgrade.

The firmware, icons etc can also be modified to suit particular requirements. If you have a special requirement or a suggestion for improvement, contact us by email at gauge.innovations@gmail.com.

Installation

What's in the box

- Temperature Gauge, dash mounted 60mm width, 52mm height, 19mm depth.
- Under the dash gauge junction box to connect 12v DC power.
- Power connector plug and cable 12v DC. Red is positive, Black is negative chassis ground.
- One waterproof digital temperature sensor including cables and connectors. Engine sensor (1 meter cable).
- Sensor junction box to mount under the vehicle bonnet.
- One coolant level sensor (1 meter cable) and mounting hardware.
- A cable (2.5 meters) to connect from the gauge junction box (normally through the firewall) to the sensor junction box under the bonnet (4 pin plug is at the gauge junction box end, 3 pin plug at the sensor junction box end).

Gauge installation is straightforward. Only three connections are required:

- One plug from the gauge to the “under the dash” gauge junction box
- One plug for power from the “under the dash” gauge junction box (2 wire, positive and negative)
- One plug from the “under the dash” gauge junction box to the temperature and coolant sensor junction box (single cable to run through the firewall)

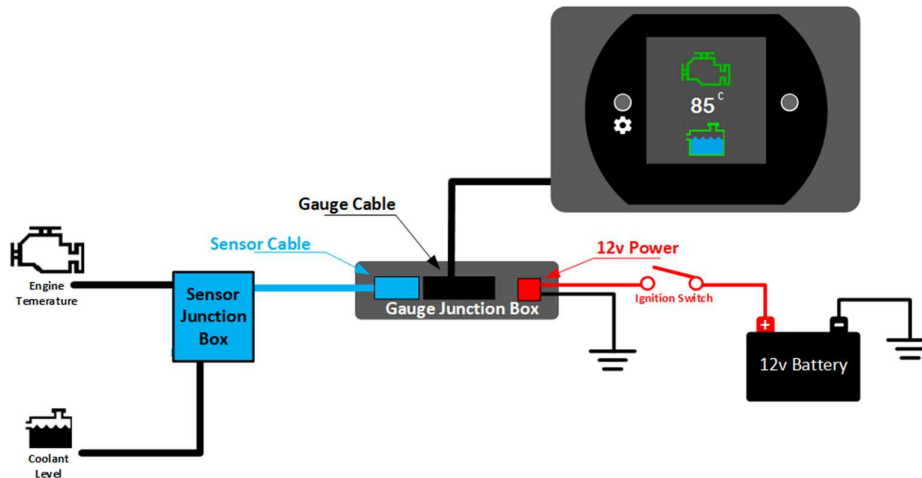

Wiring Diagram (gauge rear view)

The gauge requires 12 volts DC to operate. This should be from a switched power source that is activated by the ignition key. The gauge requires less than 25ma current during normal operation.

For best viewing, avoid installing the gauge where it will often be in direct sunlight.

The cable from the gauge to the sensors will need to be run to the central junction box located under the bonnet. Normally this will be through the firewall. Loop and secure any excess cable length.

The junction box under the bonnet is secured in a convenient location where the sensor cables can be connected.

In the case of 4WD vehicles, the junction box should be located where it will not be submerged if driving through water. Alternatively, the junction box and cable entry points can be sealed using silicone or similar material.

Temperature Sensors

The temperature sensor is mounted using an existing M8 bolt located on the engine block where the temperature will be measured. It is important that a mounting point bolt for the sensor is used which:

- Will provide reliable measurement of the engine block temperature.
- Is well away from any other sources of heat such as exhausts, turbos etc.
- Is protected from mechanical damage to the sensor or its cable
- Is well away from sources of excessive electrical noise (eg spark plugs, distributor and two-way radios)

Coolant Level Sensor

The engine coolant sensor is attached to the outside of the plastic coolant bottle using a 3M double sided pad. If required, cables ties can also be used to secure the sensor to the coolant bottle.

For the double-sided tape to adhere securely the bottle surface must be clean and dry.

The sensor should be positioned on the coolant bottle at the level you want the alarm to sound as shown below:

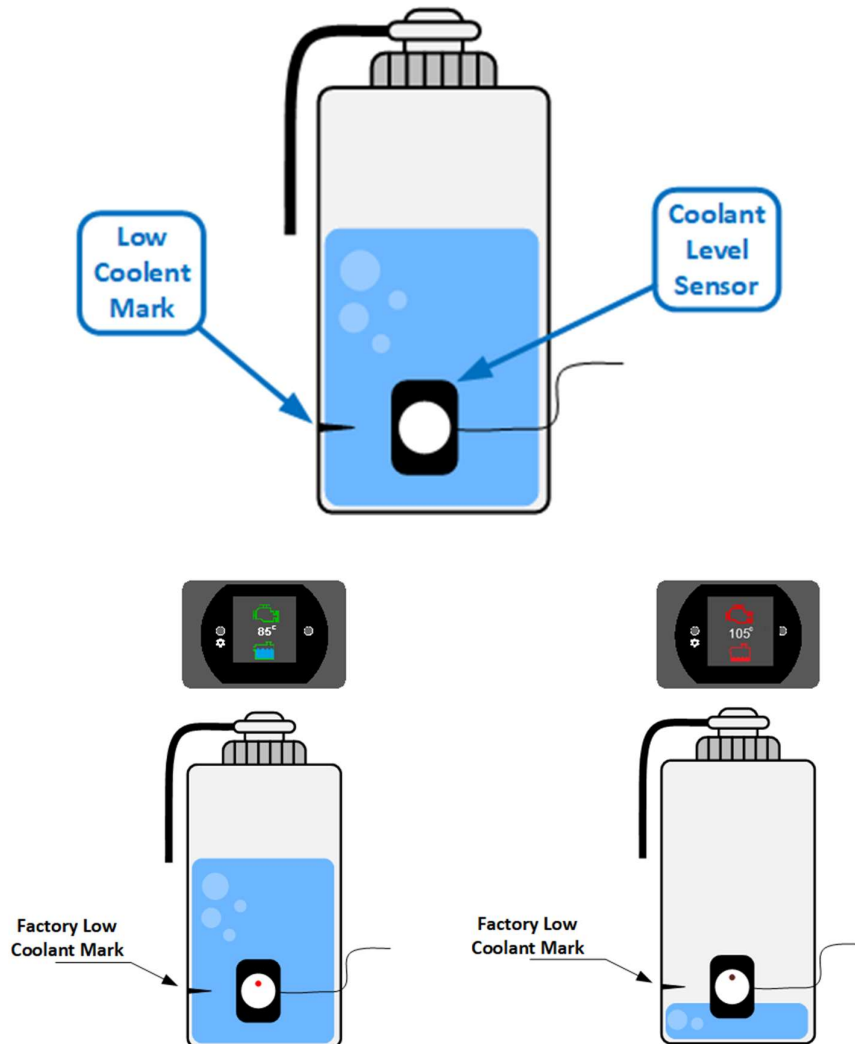

Temperature Gauge Menu and Settings Summary









Menu button cycles through the gauge settings screens.

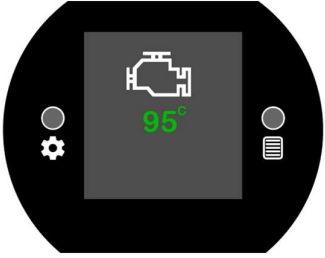

Settings button increases a setting. Press and hold to rapidly increase a setting. The setting value will only increase until it reaches the maximum value and then loop back to the lowest value where it will begin to increase with every press of the button.

Press the Menu or Settings button to silence an audible alarm.

	<p>1) SET THE HIGHEST SAFE ENGINE TEMPERATURE</p> <p>Press and release the Menu button.</p> <p>Press the Settings button to adjust the highest SAFE engine temperature. Range 0°C to 125°C (257°F).</p>
	<p>2) SET ENGINE MAXIMUM ALARM TEMPERATURE</p> <p>Press and release the Menu button again.</p> <p>Press the Settings button to adjust the engine MAXIMUM alarm temperature. The range will be from SAFE to 125°C (257°F).</p>
	<p>5) SET SCREEN BRIGHTNESS</p> <p>Press and release the Menu button again.</p> <p>Press the Settings button to adjust the screen brightness.</p>
	<p>6) TURN AUDIBLE ALARM ON/OFF</p> <p>Press and release Menu button again.</p> <p>Press the Settings button to turn the audible alarm on or off.</p> <p>NOTE: If the audible alarm is turned off, there will be no audible warning of engine temperature alarms. Please remember to keep the audible alarm setting on whenever you drive.</p>

	<p>6) SAVE SETTINGS AND RETURN TO MONITORING MODE</p> <p>Press and release the Menu button again.</p> <p>The gauge will also revert to the normal monitoring mode (temperature and coolant level display) after approximately 30 seconds of no Menu or Settings button activity.</p>
	<p>7) DISPLAY HIGHEST ENGINE TEMPERATURES</p> <p>Press the Settings button while the gauge is in monitoring mode to toggle off/on the display of the highest engine temperature reached since the gauge was powered on. The display is colour coded safe, warning or maximum.</p> <p>It can be useful to check the highest temperatures reached during normal operation as a guide to setting the SAFE and MAXIMUM levels.</p>



To restore the gauge to factory default settings - Press and hold the Settings button while the gauge is being powered on.



To toggle between Celsius and Fahrenheit temperature standards and restore the gauge to factory default settings hold down both the Menu and the Settings buttons while the gauge is being powered on.