

Ford 5.2L Mustang GT350 Supercharger System Installation Instructions

2016 Model Year*

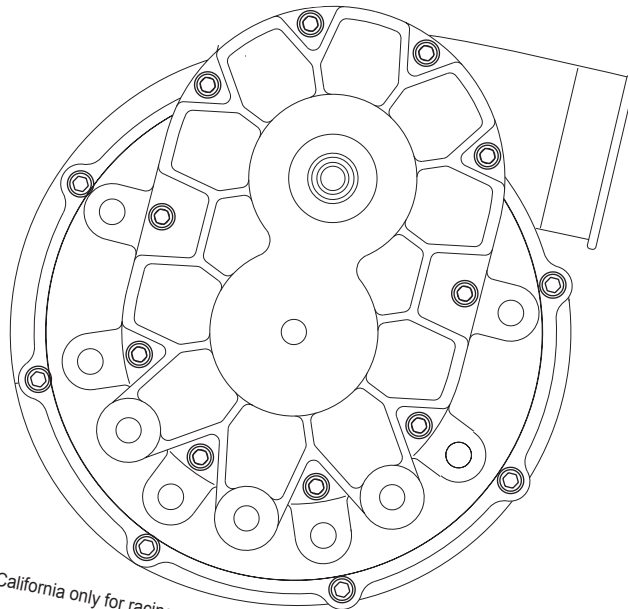

**Legal in California only for racing vehicles which may never be used or registered or licensed for use upon a highway.*



ENGINEERING, INC

1650 Pacific Avenue, Channel Islands, CA 93033-9901 • Phone (805) 247-0226
Fax: (805) 247-0669 • www.vortechsuperchargers.com • M-F 7:00 AM - 3:30 PM (PST)

FOREWORD

This manual provides information on the installation, maintenance and service of the Vortech supercharger kit expressly designed for this vehicle. All information, illustrations and specifications contained herein are based on the latest product information available at the time of this publication. Changes to the manual may be made at any time without notice. Contact Vortech Engineering for any additional information regarding this kit and any of these modifications at (805) 247-0226 7:00am-3:30pm PST.



Take note of the following before proceeding:

1. Proper installation of this supercharger kit requires general automotive mechanic knowledge and experience. Please browse through each step of this instruction manual prior to beginning the installation to determine if you should refer the job to a professional installer/technician. Please contact your dealer or Vortech Engineering for possible installers in your area.
2. This product was designed for use on stock (un-modified, OEM) vehicles. The PCM (computer), engine, transmission, drive axle ratios and tire O.D. must be stock. If the vehicle or engine has been modified in any way, check with Vortech prior to installation and use of this product.
3. Use only premium grade fuel with a minimum of 91 octane (*R+M/2*).
4. Always listen for any sign of detonation (*knocking/pinging*) and discontinue hard use (*no boost*) until problem is resolved.
5. Vortech is not responsible for any clutch, transmission, drive-line or engine damage.

Exclusions from Vortech warranty coverage considerations include, but not limited to:

1. Neglect, abuse, lack of maintenance, abnormal operation or improper installation.
2. Continued operation with an impaired vehicle or sub-system.
3. The combined use of Vortech components with other modifications such as, but not limited to, exhaust headers, aftermarket camshafts, nitrous oxide, third party PCM programming or other such changes.

©2018 VORTECH ENGINEERING, INC

All rights reserved. No part of this publication may be reproduced, transmitted, transcribed, or translated into another language in any form, by any means without written permission of Vortech Engineering, Inc.

TABLE OF CONTENTS

FOREWORD	ii
TABLE OF CONTENTS	iii
IMPORTANT NOTES	iv
TOOL & SUPPLY REQUIREMENTS	v
PARTS LIST	vi
1. BASIC COMPONENT REMOVAL	1
2. MISCELLANEOUS PREPARATION	9
3. SUPERCHARGER ASSEMBLY PREPARATION & INSTALLATION	11
3.1 MOUNTING BRACKET ASSEMBLY DIAGRAM	19
3.2 BELT ROUTING DIAGRAM	20
4. PCV SYSTEM MODIFICATION	21
5. CHARGE AIR COOLER & DISCHARGE TUBE INSTALLATION	23
6. FUEL INJECTOR REPLACEMENT	29
7. ENGINE COOLING SYSTEM MODIFICATION	31
8. AIR INLET ASSEMBLY INSTALLATION	37
8.1 - VACUUM ROUTING DIAGRAM	39
9. BYPASS VALVE CONNECTION	41
10. WINDSHIELD WASHER RESERVOIR MODIFICATION	43
11. REFLASH COMPUTER	49
12. FINAL CHECK	51

NOTICE

This product is protected by state common law, copyright and/or patent. All legal rights therein are reserved. The design, layout, dimensions, geometry, and engineering features shown in this product are the exclusive property of Vortech Engineering, Inc. This product may not be copied or duplicated in whole or part, abstractly or fundamentally, intentionally or fortuitously, nor shall any design, dimension, or other information be incorporated into any product or apparatus without prior written consent of Vortech Engineering, Inc.

2016 Ford Mustang GT350

Installation Instructions

Congratulations on selecting the best performing and best backed automotive supercharger available today... the VORTECH® supercharger!

Before beginning this installation, please read through this entire instruction booklet and the Street Supercharger System Owner's Manual which includes the Limited Warranty Program, the Warranty Registration form and return envelope.

Vortech supercharger systems are performance improving devices. In most cases, increases in torque of 30-35% and horsepower between 35-45% can be expected with the boost levels specified by Vortech Engineering. This product is intended for use on healthy, well maintained engines. Installation on a worn-out or damaged engine is not recommended and may result in failure of the engine as well as the supercharger. Vortech Engineering is not responsible for engine damage.

Installation on new vehicles will not harm or adversely affect the break-in period so long as factory break-in procedures are followed.

For best performance and continued durability, please take note of the following key points:

1. Use only premium grade fuel 91 octane or higher (R+M/2).
2. The engine must have stock compression ratio.
3. If the engine has been modified in any way, check with Vortech prior to using this product.
4. Always listen for any sign of detonation (pinging) and discontinue hard use (no boost) until problem is resolved.
5. Before beginning installation, replace all spark plugs that are older than 1 year or 15,000 miles with original heat range plugs as specified by the manufacturer and reset timing to factory specifications (follow the procedures indicated within the factory repair manual and/or as indicated on the factory underhood emissions tag). Do not use platinum spark plugs unless they are original equipment. Change spark plugs every 20,000 miles.
6. **Oil-Fed Units Only:** Perform an oil & filter change upon completion of this installation & prior to test driving your vehicle. Thereafter, always use a high-grade SF rated engine oil or a high quality synthetic, & change the oil & filter every 3,000 miles. Never attempt to extend the oil change interval beyond 3,000 miles, regardless of oil manufacturer's claims as potential damage to the supercharger may result.

TOOL & SUPPLY REQUIREMENTS

- Factory repair manual
- 3/8" socket and drive set: SAE & metric
- 1/2" socket and drive set: SAE & metric
- Adjustable wrench
- Open end wrenches: metric
- TORX T-20 driver
- Utility knife

If it has been 15,000 miles or more since your vehicle's last spark plug change, then you will also need:

- Spark plug socket
- NEW spark plugs

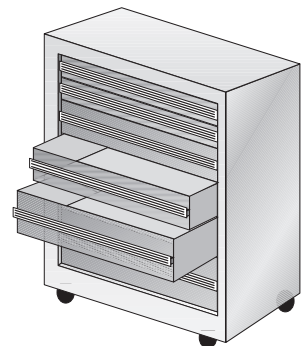



2016 Ford Mustang GT350, H.O.

Part No. 4FQ218-074L

PARTS LIST

IMPORTANT: Before beginning installation, verify that all parts are included in the kit. Report any shortages or damaged parts immediately.

PART NO.	DESCRIPTION	QTY.	PART NUMBER	DESCRIPTION	QTY.
008110	DECAL, VINYL, VORTECH	2	4FQ112-134	DISCH ASY, '16 MUST GT350, BLK	1
008130	LICENSE PLATE FRAME, VORTECH	1	4FQ012-090	DISCH. TUBE C, 2015 MUST GT	1
008447	1 YR S/C WARRANTY PKG	1	4FQ012-134	DISCH TUBE A, V-7, '15 MUST GT BLK	1
009035	S/C LUBE, BOTTLED, 3-PACK	1	4FQ017-071	SPACER TB ADAPT, '16 MUST GT350	1
2F339-124	V3 SCI ASY, '16 MUST GT350, BLK	1	4FQ112-085	ASY, DISCH TUBE B, MUST GT350	1
4FQ012-141	MOD. AIRBOX, OEM, '16 MUST GT	1	4FQ112-104	ASY, DISCH TUBE D, '15 MUST GT BLK	1
4FQ020-020	INSTR. MAN, 2016 MUST GT350	1	7C040-008	M4-.7 X 8MM SCHD SS	2
4FQ111-013	MNTG BRKT ASY, G2, 2015 MUST	1	7C060-031	M6 X 1.0 X 30 BUTN HD ZN PLT	4
2A017-875-27	SPACER, .875OD X .404ID X 1.895L	4	7C060-050	M6 X 1.0 X 50 HXHD ZINC PLATE	4
2A017-875-28	SPACER, .875 OD X 2.730 LONG	1	7F008-021	NUT, M8 X 1.25, SERRATED FLG	4
2A017-876-13	SPACER, .875OD X .328ID X 2.730L	2	7J006-093	6MM WASHER, PLATED	8
2A017-876-14	SPACER, .875OD X .328ID X 2.058L	2	7J312-875	5/16" WASHER, 7/8" OD, CUSTOM	4
2A017-876-15	SPACER, .875OD X .328ID X 2.146L	1	7P062-187	1/16 NPT X 3/16 HOSE BARB	1
2A017-876-16	SPACER, .875OD X .328ID X 1.928L	1	7P157-219	REDUCER UNION, 5/32" TO 7/32"	1
2A046-031	BELT, 6 RIB X 103.31 EFF. LENGTH	1	7P500-016	TEE, .5X.5X1/16NPT, METAL	1
4FQ010-011	MNTG PLT, OUTER, 2011 MSTG 5.0	1	7PS300-277	SLEEVE, BUMP REDUCER, 3.0- 2.75	1
4FQ010-021	MNTG PLT, INNER, 2011 MSTG 5.0	1	7PS300-300	SLEEVE, BLACK, 3.00D X 3.00	2
4FQ017-021	SPCR, .875/1.25OD X .328ID X 1.782L	1	7PS300-301	BUMP HOSE, 3.00D X 3.00L	1
4FQ017-031	SPCR, .875ODX.404IDX.363L W/.66 PLT	4	7PS350-300	REDUCR, BLK 3.5-3 X 2.3LG, MOD	1
4GF016-161	PULLEY, 3" IDLER, GROOVED, MOD	1	7PS350-304	SLEEVE, BLACK 3.50" D X 3.0" L	1
4PCS016-160	PULLEY, IDLER, SRT10 TRUCK	1	7PS400-350	REDUCER, BLK 4.0-3.5 X 3.0L	1
4TX016-150	IDLER, 2.75 DIA, SMOOTH, 7 RIB	2	7PS400-382	ELBOW, 4.0 X 3.82 S-SHAPE, SILICONE	1
7A375-126	3/8-16 X 1.25 HHCS, GR8, PLT	5	7R002-044	#44 SAE TYPE F SS HOSE CLAMP	1
7A375-352	3/8-16 X 3.5" HX HD GR8	1	7R002-048	#48 SAE TYPE F SS HOSE CLAMP	7
7C080-064	M8 X 1.25 X 65MM BHCS CL10.9	5	7R002-056	#56 SAE TYPE F SS HOSE CLAMP	5
7C080-081	M8 X 1.25 X 80 HXHD CL10.9	1	7R002-064	#64 SAE TYPE F SS HOSE CLAMP	2
7C080-101	M8-1.25 X 100 BHCS CL10.9	1	7U012-240	O-RING, 2-240, 3.734 ID X .139	1
7C080-200	M8-1.25 X 200MM STUD, 35MM THREAD	2	7U030-046	5/32" VACUUM LINE	.025FT
7F008-021	NUT, M8 X 1.25, SERRATED FLG	2	7U030-218	7/32 VAC HOSE, BUNA-N	5FT
7J312-000	5/16 FLAT WASHER-SAE	3	8A003-074	MAF, 3.8 ID, BLACK	1
7K375-040	3/8 AN960 FLAT WASHR PLATED	9	8H040-175	FILTER, 1.75" I.D., RACE BYPASS	1
7K375-050	3/8 WASHER, STAINLS, .030THK	1	4FQ114-030	ENG COOL SYS MOD ASY, '15 MUST	1
4FQ112-113	AIR INLET ASY,CF,'15 MUST GT350	1	5W001-085	SLEEVE, FLEX BRAID 1.5" NOM.	1
008358	DECAL, INLET, 2011 MSTG GT VORT	1	7P312-050	5/16 UNION HOSE MENDER	1
4FQ012-113	INLET DUCT, CARBON, 15-17 MUST 5.0	1	7P375-050	3/8 HOSE UNION, BRASS	1
5W001-039	1" HEAT SHRINK TUBING	3IN	7P375-075	3/4" HOSE BARB UNION, BRASS	1
5W001-082	SLEEVE, FLEX BRAID .75" NOM.	.75FT	7P375-098	TEE, 3/8 INCH, PLASTIC	1
7J006-093	6MM WASHER, PLATED	2	7R002-024	#24 SAE TYPE F SS HOSE CLAMP	1
7P250-045	1/4 MALE NPT X 3/8 MALE BARB	1	7R004-001	STEPLESS CLAMP, 15.7-70	4
7P375-098	TEE, 3/8" INCH, PLASTIC	1	7R004-002	STEPLESS CLAMP, 17.0-70	7
7P375-106	PCV VALVE, FORD, 3/8" HOSE	1	7R004-007	STEPLESS CLAMP, 28.6 X 7MM	2
7P375-378	VALVE, CHECK, 3/8 BARB X 3/8 BARB	1	7U030-056	3/8 PCV/VAC RUBBER HOSE	2.5
7P500-039	1/2 NPT X 5/8 BARB 90 , PLATED	1	7U030-065	HOSE, 3/4 X 90° RUBBER, SHORT	1
7P625-091	5/8 X 5/8 X 90 BARB ELBOW, PLASTIC	1	7U030-109	VAC HOSE, 7/64 ID	.50FT
7P625-375	REDUCER, 5/8 BARB TO 3/8 BARB	1	7U031-016	5/16 PCV/VAC RUBBER HOSE	1
7PS375-100	SLEEVE, 3.75 X 1.0 3-PLY MATTE BLK	1	7U038-000	3/4 HEATER HOSE	3
7PS400-200	SLEEVE, BLACK 4.0D X 2.0	1	8N155-090	WATER TANK WELD ASY, 2015 MUST	1
7PS400-225	BUMP SLEEVE, 4 X 2.25, BLACK	1	4FQ155-021	WASHER RESERVOIR ASY, GT350	1
7PS400-351	REDUCER SLEEVE, 4.0 X 3.5 X 2.35L	1	4GE055-010	TANK "A", WSHR FLUID, 2 QT	1
7R002-052	#52 SAE TYPE F SS HOSE CLAMP	1	4GE055-020	CAP, BUTTRESS THRD UNVNTD 2-1/4	1
7R002-064	#64 SAE TYPE F SS HOSE CLAMP	4	4GE055-030	TANK, RMT FILL WSHR FLUID, W/ CAP	1
7R004-002	STEPLESS CLAMP, 17.0-70	6	7A250-039	1/4-20 X .375 BHCS	4
7R004-004	STEPLESS CLAMP, 25.6 X 7MM	10	7A250-074	1/4-20 X .75 HHCS PLTD	2
7R004-007	STEPLESS CLAMP, 28.6 X 7MM	2	7F250-021	1/4-20 NYLOCK NUT ZINC PLATED	2
7U030-056	3/8 PCV/VAC RUBBER HOSE	3FT	7J250-001	1/4 WASHER, SAE, PLTD	6
7U033-000	5/8" PCV HOSE	1.75FT	7J312-875	5/16" WASHER, 7/8" OD, CUSTOM	1
7U100-055	TIE WRAP, 7.5" NYLON	10	7P375-625	3/8 NPT X 5/8 HOSE FTG, BARBED	1
8A004-007-1	BLK OFF PLT, VORT, FORD SLOT MAF	1	7P625-091	5/8 X 5/8 X 90 BARB ELBOW, PLASTIC	1
			7R002-010	#10 SAE TYPE F SS HOSE CLAMP	1
			7R004-004	STEPLESS CLAMP, 25.6 X 7MM	3
			7U033-000	5/8" PCV HOSE	1FT
			5A003-070	SCT TUNER, '11-'16 MUST GT	1
			5W001-097	HRNSS,TB EXTEN,'16 MUST GT350	1
			8D204-064	RACE BYPASS VALVE, G3 BLK/SAT	1
			8F060-725	FUEL INJ, ID725, 2011 MUST	8
			8H040-205	AIR FILTER, 2015 MSTG GT PANEL	1
			8PN101-054	WELDED CORE ASY,05 MUST, BLK	1



2016 Ford Mustang GT350, H.O. Tuner Kit

Part No. 4FQ218-174L

PARTS LIST

IMPORTANT: Before beginning installation, verify that all parts are included in the kit. Report any shortages or damaged parts immediately.

PART NO.	DESCRIPTION	QTY.	PART NUMBER	DESCRIPTION	QTY.
008110	DECAL, VINYL, VORTECH	2	4FQ112-134	DISCH ASY, '16 MUST GT350, BLK 1	
008130	LICENSE PLATE FRAME, VORTECH	1	4FQ012-090	DISCH. TUBE C, 2015 MUST GT	1
008447	1 YR S/C WARRANTY PKG	1	4FQ012-134	DISCH TUBE A, V-7, '15 MUST GT BLK	1
009035	S/C LUBE, BOTTLED, 3-PACK	1	4FQ017-071	SPACER TB ADAPT, '16 MUST GT350	1
2F339-124	V3 SCI ASY, '16 MUST GT350, BLK 1		4FQ112-085	ASY, DISCH TUBE B, MUST GT350	1
4FQ012-141	MOD. AIRBOX, OEM, '16 MUST GT 1		4FQ112-104	ASY, DISCH TUBE D, '15 MUST GT BLK	1
4FQ020-020	INSTR. MAN, 2016 MUST GT350 1		7C040-008	M4-.7 X 8MM SCHD SS	2
4FQ111-013	MNTG BRKT ASY, G2, 2015 MUST 1		7C060-031	M6 X 1.0 X 30 BUTN HD ZN PLT	4
2A017-875-27	SPACER, .875OD X .404ID X 1.895L	4	7C060-050	M6 X 1.0 X 50 HXHD ZINC PLATE	4
2A017-875-28	SPACER, .875 OD X 2.730 LONG	1	7F008-021	NUT, M8 X 1.25, SERRATED FLG	4
2A017-876-13	SPACER, .875OD X .328ID X 2.730L	2	7J006-093	6MM WASHER, PLATED	8
2A017-876-14	SPACER, .875OD X .328ID X 2.058L	2	7J312-875	5/16" WASHER, 7/8" OD, CUSTOM	4
2A017-876-15	SPACER, .875OD X .328ID X 2.146L	1	7P062-187	1/16 NPT X 3/16 HOSE BARB	1
2A017-876-16	SPACER, .875OD X .328ID X 1.928L	1	7P157-219	REDUCER UNION, 5/32" TO 7/32"	1
2A046-031	BELT, 6 RIB X 103.31 EFF. LENGTH	1	7P500-016	TEE, .5X.5X1/16NPT, METAL	1
4FQ010-011	MNTG PLT, OUTER, 2011 MSTG 5.0	1	7PS300-277	SLEEVE, BUMP REDUCER, 3.0- 2.75	1
4FQ010-021	MNTG PLT, INNER, 2011 MSTG 5.0	1	7PS300-300	SLEEVE, BLACK, 3.00D X 3.00	2
4FQ017-021	SPCR, .875/1.25OD X .328ID X 1.782L	1	7PS300-301	BUMP HOSE, 3.00D X 3.00L	1
4FQ017-031	SPCR, .875ODX.404IDX.363L W/.66 PLT	4	7PS350-300	REDUCR,BLK 3.5-3 X 2.3LG, MOD	1
4GF016-161	PULLEY, 3" IDLER, GROOVED, MOD	1	7PS350-304	SLEEVE, BLACK 3.50" D X 3.0" L	1
4PCS016-160	PULLEY, IDLER, SRT10 TRUCK	1	7PS400-350	REDUCER, BLK 4.0-3.5 X 3.0L	1
4TX016-150	IDLER, 2.75 DIA, SMOOTH, 7 RIB	2	7PS400-382	ELBOW, 4.0 X 3.82 S-SHAPE, SILICONE	1
7A375-126	3/8-16 X 1.25 HHCS, GR8, PLT	5	7R002-044	#44 SAE TYPE F SS HOSE CLAMP	1
7A375-352	3/8-16 X 3.5" HX HD GR8	5	7R002-048	#48 SAE TYPE F SS HOSE CLAMP	7
7C080-064	M8 X 1.25 X 65MM BHCS CL10.9	1	7R002-056	#56 SAE TYPE F SS HOSE CLAMP	5
7C080-081	M8 X 1.25 X 80 HXHD CL10.9	1	7R002-064	#64 SAE TYPE F SS HOSE CLAMP	2
7C080-101	M8-1.25 X 100 BHCS CL10.9	1	7U012-240	O-RING, 2-240, 3.734 ID X .139	1
7C080-200	M8-1.25 X 200MM STUD, 35MM THREAD	2	7U030-046	5/32" VACUUM LINE	.025FT
7F008-021	NUT, M8 X 1.25, SERRATED FLG	2	7U030-218	7/32 VAC HOSE, BUNA-N	5FT
7J312-000	5/16 FLAT WASHER-SAE	3	8A003-074	MAF, 3.8 ID, BLACK	1
7K375-040	3/8 AN960 FLAT WASHR PLATED	9	8H040-175	FILTER, 1.75" I.D., RACE BYPASS	1
7K375-050	3/8 WASHER, STAINLS, .030THK	1			
4FQ112-113	AIR INLET ASY,CF,'15 MUST GT350 1		4FQ114-030	ENG COOL SYS MOD ASY, '15 MUST1	
008358	DECAL, INLET, 2011 MSTG GT VORT	1	5W001-085	SLEEVE, FLEX BRAID 1.5" NOM.	1
4FQ012-113	INLET DUCT, CARBON, 15-17 MUST 5.0	1	7P312-050	5/16 UNION HOSE MENDER	1
5W001-039	1" HEAT SHRINK TUBING	3IN	7P375-050	3/8 HOSE UNION, BRASS	1
5W001-082	SLEEVE, FLEX BRAID .75" NOM.	.75FT	7P375-075	3/4" HOSE BARB UNION, BRASS	1
7J006-093	6MM WASHER, PLATED	2	7P375-098	TEE, 3/8 INCH, PLASTIC	1
7P250-045	1/4 MALE NPT X 3/8 MALE BARB	1	7R002-024	#24 SAE TYPE F SS HOSE CLAMP	1
7P375-098	TEE, 3/8" INCH, PLASTIC	1	7R004-001	STEPLESS CLAMP, 15.7-70	4
7P375-106	PCV VALVE, FORD, 3/8" HOSE	1	7R004-002	STEPLESS CLAMP, 17.0-70	7
7P375-378	VALVE, CHECK, 3/8 BARB X 3/8 BARB	1	7R004-007	STEPLESS CLAMP, 28.6 X 7MM	2
7P500-039	1/2 NPT X 5/8 BARB 90 , PLATED	1	7U030-056	3/8 PCV/VAC RUBBER HOSE	2.5
7P625-091	5/8 X 5/8 X 90 BARB ELBOW, PLASTIC	1	7U030-065	HOSE, 3/4 X 90° RUBBER, SHORT	1
7P625-375	REDUCER, 5/8 BARB TO 3/8 BARB	1	7U030-109	VAC HOSE, 7/64 ID	.50FT
7PS375-100	SLEEVE, 3.75 X 1.0 3-PLY MATTE BLK	1	7U031-016	5/16 PCV/VAC RUBBER HOSE	1
7PS400-200	SLEEVE, BLACK 4.0D X 2.0	1	7U038-000	3/4 HEATER HOSE	3
7PS400-225	BUMP SLEEVE, 4 X 2.25, BLACK	1	8N155-090	WATER TANK WELD ASY, 2015 MUST	1
7PS400-351	REDUCER SLEEVE, 4.0 X 3.5 X 2.35L	1			
7R002-052	#52 SAE TYPE F SS HOSE CLAMP	1	4FQ155-021	WASHER RESERVOIR ASY, GT350 1	
7R002-064	#64 SAE TYPE F SS HOSE CLAMP	4	4GE055-010	TANK "A", WSHR FLUID, 2 QT	1
7R004-002	STEPLESS CLAMP, 17.0-70	6	4GE055-020	CAP, BUTTRESS THRD UNVNTD 2-1/4	1
7R004-004	STEPLESS CLAMP, 25.6 X 7MM	10	4GE055-030	TANK, RMT FILL WSHR FLUID, W/ CAP	1
7R004-007	STEPLESS CLAMP, 28.6 X 7MM	2	7A250-039	1/4-20 X .375 BHCS	4
7U030-056	3/8 PCV/VAC RUBBER HOSE	3FT	7A250-074	1/4-20 X .75 HHCS PLTD	2
7U033-000	5/8" PCV HOSE	1.75FT	7F250-021	1/4-20 NYLOCK NUT ZINC PLATED	2
7U100-055	TIE WRAP, 7.5" NYLON	10	7J250-001	1/4 WASHER, SAE, PLTD	6
8A004-007-1	BLK OFF PLT, VORT, FORD SLOT MAF	1	7J312-875	5/16" WASHER, 7/8" OD, CUSTOM	1
			7P375-625	3/8 NPT X 5/8 HOSE FTG, BARBED	1
			7P625-091	5/8 X 5/8 X 90 BARB ELBOW, PLASTIC	1
			7R002-010	#10 SAE TYPE F SS HOSE CLAMP	1
			7R004-004	STEPLESS CLAMP, 25.6 X 7MM	3
			7U033-000	5/8" PCV HOSE	1FT
			5W001-097	HRNSS,TB EXTEN,'16 MUST GT350 1	
			8D204-064	RACE BYPASS VALVE, G3 BLK/SAT 1	
			8H040-205	AIR FILTER, 2015 MSTG GT PANEL 1	
			8PN101-054	WELDED CORE ASY,05 MUST, BLK 1	

This page was left intentionally blank.

1. BASIC COMPONENT REMOVAL

- A. Remove the 6x 8mm-headed fasteners securing the front bumper cover to the upper radiator support. Set aside for later re-installation.

(See Fig. 1-a)



Fig. 1-a: Remove Bumper Cover Fasteners

- B. There are 2x 5.5mm-headed fasteners (one on each side) hidden underneath the weather stripping on the top of the bumper cover near the headlights. Remove these fasteners & set aside for later re-installation.

(See Fig. 1-b)



Fig. 1-b: Remove 5.5mm-Headed Fastener

- C. Remove the 2x plastic fasteners securing the brake cooling duct to the inner fender liner. Do this for both sides.

(See Fig. 1-c)



Fig. 1-c: Remove Fender Liner Fasteners

1. BASIC COMPONENT REMOVAL, cont'd

- D. In order to allow adequate working space to access the backside of the front bumper cover, it is suggested to remove all of the plastic fasteners securing the fender liners to the fenders & front undertray & allowing the inner fender liner to rest on top of the wheels. Do this for both sides.

(See Fig. 1-d)



Fig. 1-d: Remove Fender Liner Fasteners

- E. Remove the 6x T25 screws securing the rear section of the front splitter to the belly pan. Located inside the 4x elongated slots on the front splitter are 4x 7mm-headed screws securing the front splitter to the front bumper cover. These will also need to be removed. Once all fasteners have been removed, push the front splitter forward to detach it from the front bumper cover.

(See Fig. 1-e)



Fig. 1-e: Remove Front Splitter

- F. Remove the 2x T25 screws & 1x 7mm-headed screw securing the corner of the front bumper cover to the belly pan. Do this for both sides.

(See Fig. 1-f)



Fig. 1-f: Remove Screws Securing Front Bumper Corners

1. BASIC COMPONENT REMOVAL, cont'd

- G. Remove the 6x 7mm-headed fasteners securing the belly pan to the front bumper cover.
(See Fig. 1-g)



Fig. 1-g: Remove Front Belly Pan Screws

- H. There are 2x 7mm-headed fasteners (one per side) securing the corners of the front bumper cover to the fender. With the fender liners out of the way, reach behind the front bumper cover & remove these fasteners. Once removed, pull the corners of the front bumper cover away from the fender. Carefully remove the front bumper cover from the vehicle, making sure to unplug the turn signal harness connector from the main harness.
(See Fig. 1-h)



Fig. 1-h: Bumper Corner Fastener
(Bumper Removed)

- I. Located along the outer perimeter of the upper & lower sections of the radiator shroud are a number of plastic fasteners securing rubber shrouding to the radiator shroud. You will need to remove those plastic fasteners in order to remove the radiator shroud assembly in the next step.
(See Fig. 1-i)

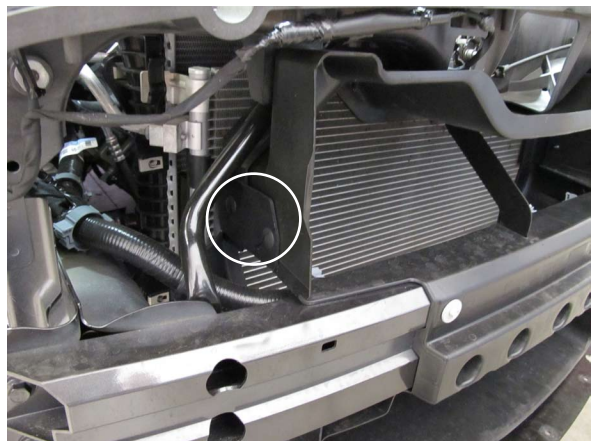

Fig. 1-i: Remove Plastic Fasteners

1. BASIC COMPONENT REMOVAL, cont'd

- J. Remove the 4x 10mm-headed fasteners & 3x plastic fasteners securing the radiator shroud to the front of the vehicle. Unplug the ambient air temperature sensor, then remove the shroud & set aside.

(See Fig. 1-j)



Fig. 1-j: Remove Radiator Shroud

- K. You will notice a wire harness running along the back side of the bumper support secured by 3x gray clips. Free the harness from the bumper support.

(See Fig. 1-k)



Fig. 1-k: Wire Harness

- L. Release the gray clips from the wire harness & set aside. These will not be reused.

(See Fig. 1-l)



Fig. 1-l: Gray Clip Removal

1. BASIC COMPONENT REMOVAL, cont'd

- M. Loosen the hose clamp securing the air inlet tube to the throttle body, then proceed to detach the breather hoses from the air inlet tube.

(See Fig. 1-m)



Fig. 1-m: Loosen Hose Clamp & Detach Breather Hoses

- N. Remove the 10mm-headed screw securing the air box to the vehicle. Unplug the MAF sensor connector & remove the air inlet assembly from the vehicle.

(See Fig. 1-n)



Fig. 1-n: Unplug MAF & Remove Air Inlet Assembly

- O. Remove the pressure cap from the engine coolant reservoir near the passenger side front of the engine compartment. Locate the engine coolant drain valve at the bottom passenger side corner of the radiator. Open the valve and drain the coolant into a clean container for later reuse. Drain enough to empty the reservoir and below the level of the upper radiator hose.

(See Fig. 1-o)

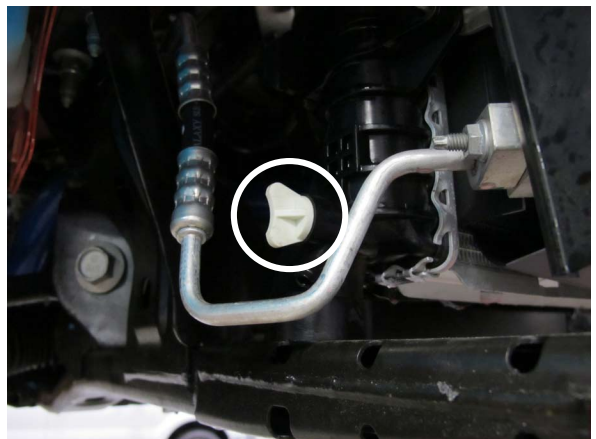

Fig. 1-o: Drain Engine Coolant

1. BASIC COMPONENT REMOVAL, cont'd

- P. Unclamp and detach the two small hoses from the upper portion of the coolant reservoir & disconnect the larger hose from the bottom of the coolant reservoir. Be prepared to catch any spillage. Remove the 2x 10mm-headed fasteners securing the coolant reservoir. Remove the reservoir and set it aside. It will not be reused.

(See Fig. 1-p)

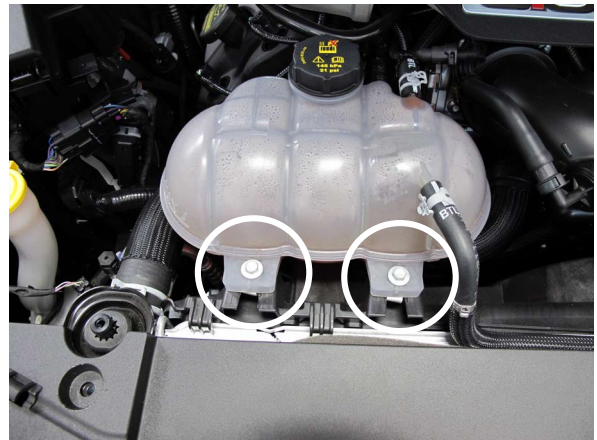

Fig. 1-p: Remove Coolant Reservoir

- Q. Release the upper radiator hose clamp connection to the radiator. Release the quick release upper radiator hose connection to the thermostat housing by pulling the spring clip back and sliding the hose fitting off. Remove the upper radiator hose and set it aside for later modification. Remove the coolant hose to the right of the "Y" fitting, above the thermostat housing & set it aside. It will not be reused.

(See Fig. 1-q)

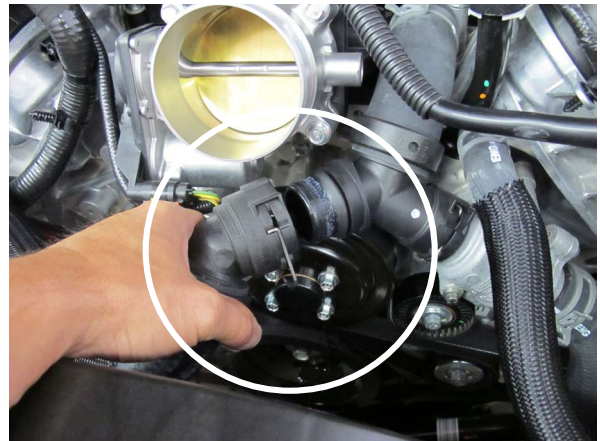

Fig. 1-q: Remove Upper Radiator Hose

- R. Use a 15mm wrench to rotate the belt tensioner counter-clockwise to release tension from the outer 6-rib accessory drive belt. Remove the belt and set it aside as it will not be reused.

(See Fig. 1-r)



Fig. 1-r: Remove Accessory Drive Belt

1. BASIC COMPONENT REMOVAL, cont'd

- S. Remove the 2x T-20 fasteners securing the MAF insert to the OEM airbox. Remove the MAF insert and set aside for later use.

(See Fig. 1-s)



*Fig. 1-s: MAF Insert
(shown with OEM airbox removed)*

- T. Unplug the electrical connector from the throttle body by sliding the red clip outward and depressing the tab. Remove the 4x 8mm-headed screws securing the throttle body to the intake manifold. These fasteners will not be reused. Remove the throttle body and set it aside for later reinstallation, ensuring that the sealing gasket remains in the intake manifold. Temporarily place a rag in the intake manifold to keep foreign debris from entering the intake manifold.

(See Fig. 1-t)

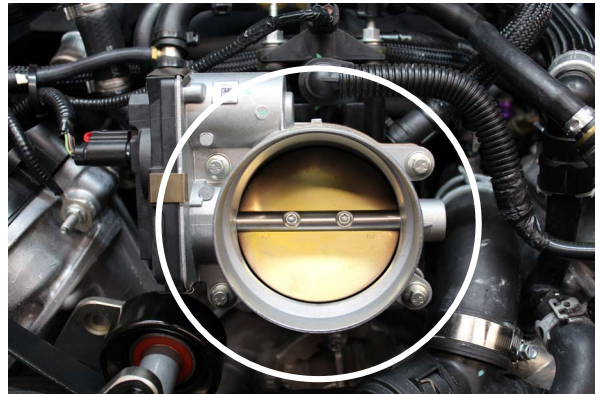

Fig. 1-t: Remove Throttle Body

This page was left intentionally blank.

2. MISCELLANEOUS PREPARATION

- A. Free the large wiring harness from the 2x mounting locations on the engine front cover forward of the passenger side cylinder head. Use extra care when disengaging the lower clip from the threaded hole in the engine cover as this threaded hole will be used in a later step. If part of the clip breaks off in the threaded hole, carefully extract it without damaging the threads. Route the harness higher up along the passenger side valve cover. (See Fig. 2-a)

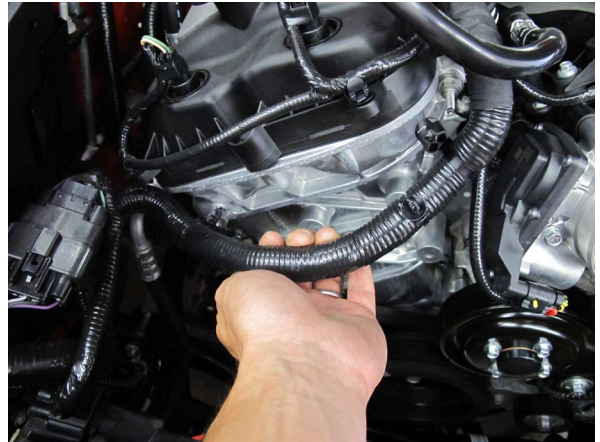

Fig. 2-a: Detach Wiring Harness

- B. Cut off the coolant reservoir mount closest to the drivers side of the vehicle. This is to make room for the new air inlet tube. You may need to make further adjustments when you install the air inlet tube. (See Fig. 2-b)

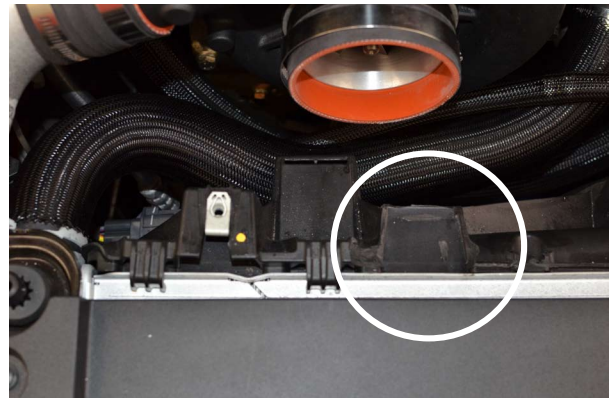

Fig. 2-b: Coolant Reservoir Mount (Removed)

- C. Remove the battery cover by removing the 3x plastic fasteners & pulling the battery cover forward. (See Fig. 2-c)



Fig. 2-c: Remove Battery Cover

2. MISCELLANEOUS PREPARATION, cont'd

- D. If your vehicle is equipped with a strut tower brace, you may remove it at this time.
(See Fig. 2-d)



Fig. 2-d: Remove Strut Tower Brace

- E. Unplug the battery leads.
(See Fig. 2-e)



Fig. 2-e: Unplug Battery Leads

3. SUPERCHARGER ASSEMBLY PREPARATION & INSTALLATION

- A. Using a coarse file or similar tool, remove approximately 1/8" from the front edge of the passenger side valve cover tab. This will ensure proper supercharger-to-valve cover clearance during installation.

(See Fig. 3-a)



Fig. 3-a Modify Tab

- B. Remove the following 3x 10mm-headed screws securing the engine front cover on the passenger side:

- The uppermost screw
- The screw just above the A/C compressor
- The screw between the A/C compressor and the crankshaft

(See Fig. 3-b)

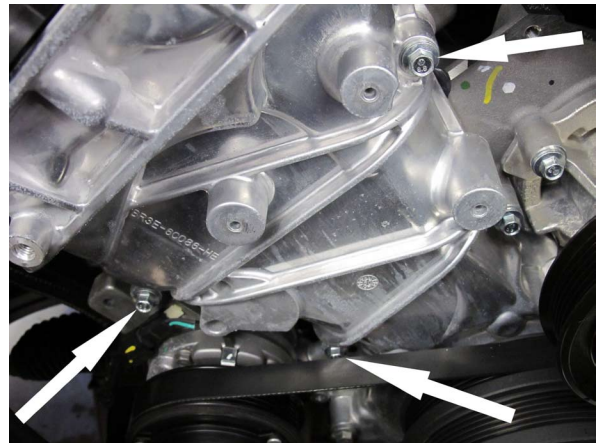

Fig. 3-b: Remove Engine Cover Screws

- C. Inspect the supercharger mounting plate/idler pulley assembly and familiarize yourself with its components and configuration. The new belt should be routed so that the ribbed side engages the ribbed idler pulley and the smooth side rides on the other pulleys. Note the multiple mounting locations of the ribbed idler, used to compensate for different supercharger pulley sizes and belt lengths. All 4x idler mounting bolts should be hand-tight during installation to facilitate alignment.

(See Fig. 3-c)



Fig. 3-c: Inspect Mounting Bracket Assembly

3. SUPERCHARGER ASSEMBLY PREPARATION & INSTALLATION, cont'd

- D. Remove the smooth idler, 1.895" spacer, pilot spacer, 3/8-16 x 3.50" screw & 3/8 AN washer closest to the top of the bracket & set aside for re-use in a later step. Remove the 1.928" spacer, M8 x 80mm screw & 5/16 washer & set aside for re-use in a later step. Remove the 2.058" spacer from the M8 x 100mm button-head screw & set aside for re-use in a later step. Also, discard the provided cone-shaped 1.782" spacer & M8 x 65mm button head screw included in this bracket assembly. They are not required for 2015+ model-year vehicles.

(See Fig. 3-d)

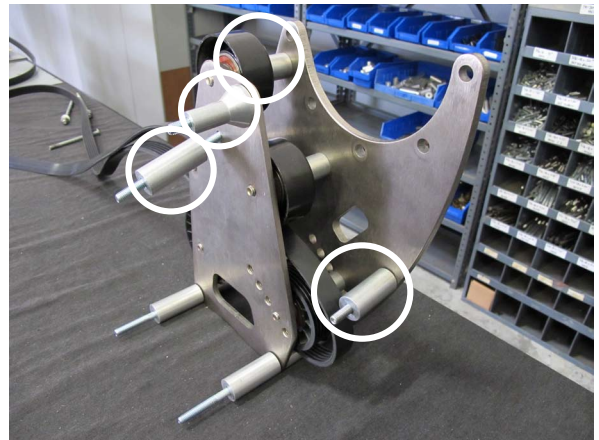

Fig. 3-d: Remove Spacers & Hardware (Circled)

- E. Remove the 2.058" spacer, 2.146" spacer, 2x M8 x 200mm studs, 2x M8 flanged nuts & 2x 5/16" washers & set aside for use in a later step.

(See Fig. 3-e)

NOTE: The 2x 2.730" spacers sandwiched in between the mounting plates (not shown) are held in place by the 2x M8 x 200mm studs. These spacers need to remain in place during installation of the mounting bracket assembly.

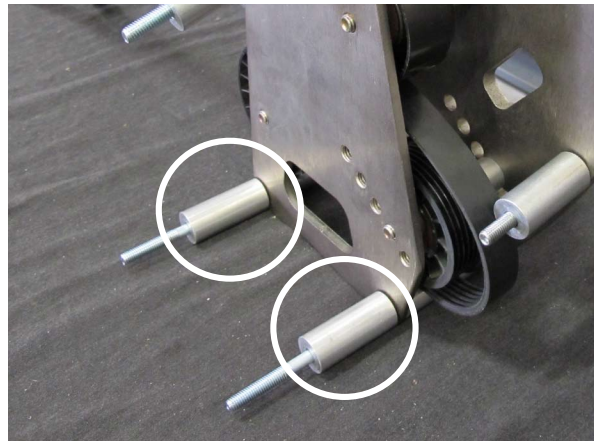

Fig. 3-e: Remove Spacers & Hardware (Circled)

- F. Thread the 2x provided M8 x 200mm studs into the lower 2x engine cover fastener holes, in the locations of the previously-removed fasteners (one just above the A/C compressor and one between the A/C compressor and the crankshaft). Use a small amount of blue thread lock on the threads.

(See Fig. 3-f)

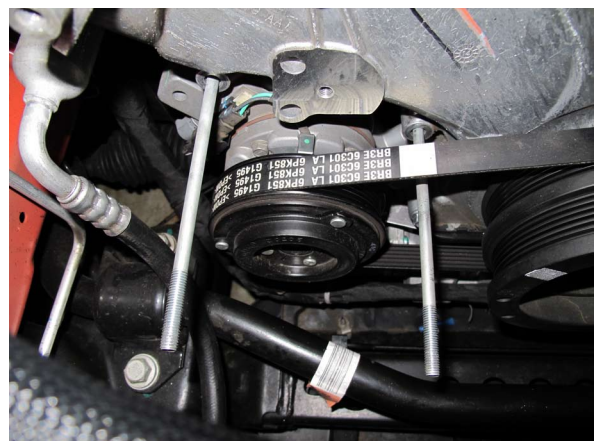

Fig. 3-f: Thread Studs Into Engine Cover Fastener Holes

3. SUPERCHARGER ASSEMBLY PREPARATION & INSTALLATION, cont'd

- G. Slide 1x 2.058" spacer over the stud above the A/C compressor. Slide 1x 2.146" spacer over the stud between the A/C compressor and the crankshaft. Measuring from the face of the spacers (closest to the front of the vehicle), leave 3.75" of the M8 x 200mm stud exposed. (See Fig. 3-g)

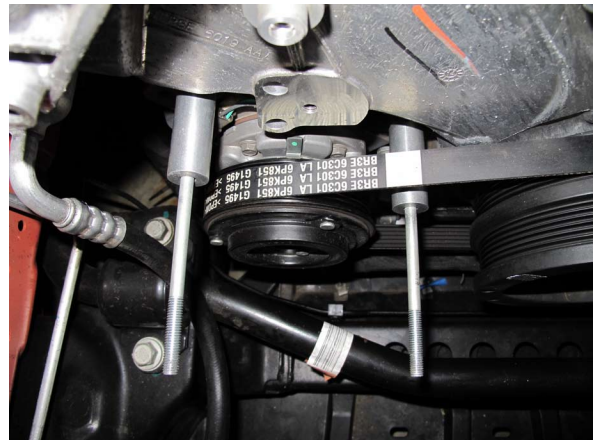

Fig. 3-g: Slide 2.058" & 2.146" Spacers Onto Studs

- H. As mentioned in the note in Step E, the 2x 2.730" spacers sandwiched in between the mounting plates are normally held in place by the 2x M8 x 200mm studs. During the installation of the mounting bracket assembly to the vehicle, make sure that the 2x M8 x 200mm studs pass through the mounting plates & both spacers. (See Fig. 3-h)

NOTE: Slightly tightening the 4x 3/8-16 x 3.50" screws holding the mounting bracket assembly together will trap the 2x 2.730" spacers & help keep them in place while you install the mounting bracket assembly to the vehicle.

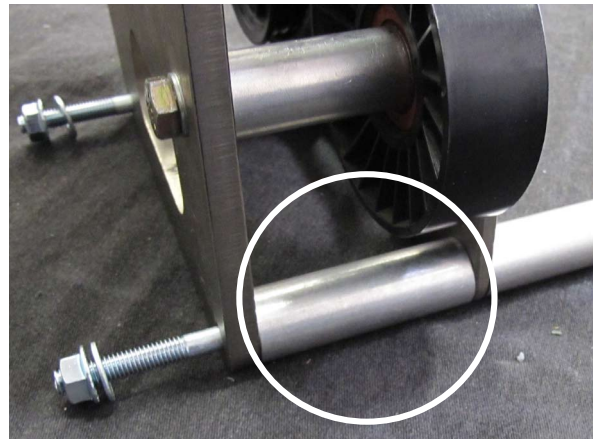

Fig. 3-h: Trap 2x 2.730" Spacers Between Mounting Plates

- I. Position the mounting bracket assembly in the engine compartment, then slide the 2x lower mounting holes onto the 2x M8 x 200mm studs, making sure they pass through both mounting plates & the 2x 2.730" spacers sandwiched in between the mounting plates. (See Fig. 3-i)

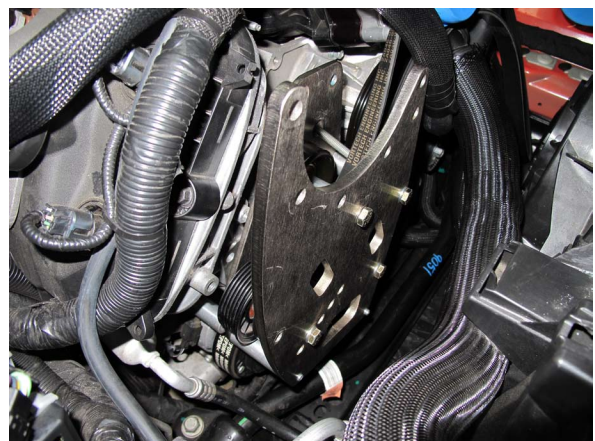

Fig. 3-i: Slide Mounting Bracket Assembly Onto Studs

3. SUPERCHARGER ASSEMBLY PREPARATION & INSTALLATION, cont'd

- J. Locate the previously removed 2.058" spacer & place it between the rear mounting plate & the uppermost engine timing cover hole. Using a 5mm hex tool, secure the M8 x 100mm button head screw to the uppermost engine timing cover hole. (See Fig. 3-j)

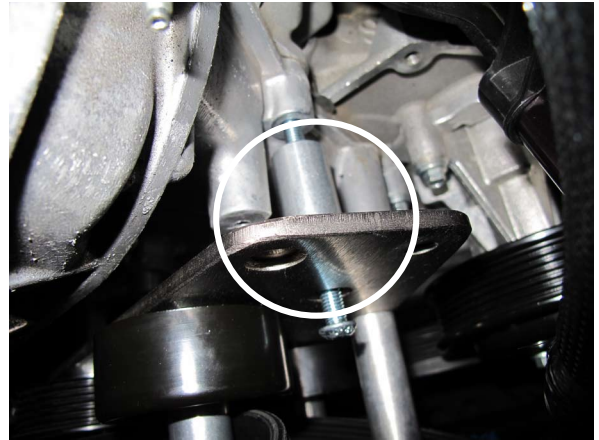

Fig. 3-j: Secure Top Of Rear Mounting Plate

- K. Locate the previously removed 1.928" spacer, M8 x 80mm screw & 5/16 washer. Place the spacer in between the front mounting plate & cylinder head. Using the M8 x 80mm screw & 5/16 washer, secure the front plate & spacer to the cylinder head. (See Fig. 3-k)

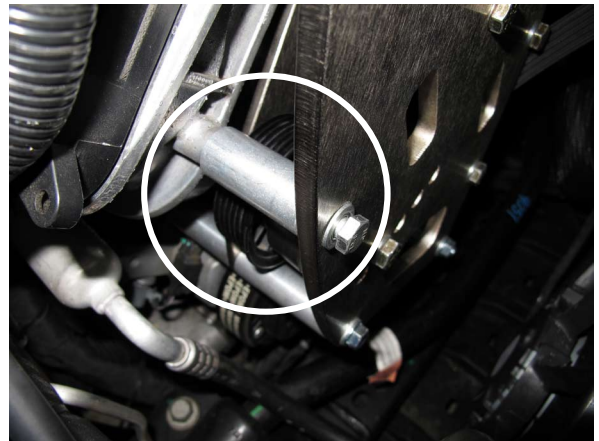

Fig. 3-k: Secure Left Side Of Front Mounting Plate

- L. Locate the previously removed 2x M8 flanged nuts & 2x 5/16 washers & use them to secure the lower section of the bracket to the previously installed 2x M8 x 200mm studs. (See Fig. 3-l)



Fig. 3-l: Secure Lower Mounting Bracket Fasteners

3. SUPERCHARGER ASSEMBLY PREPARATION & INSTALLATION, cont'd

- M. Locate the previously removed smooth idler, 1.895" spacer, pilot spacer, 3/8-16 x 3.50" screw & 3/8 AN washer. Place the smooth idler, 1.895" spacer & pilot spacer into their appropriate location between the mounting plates, then secure with the 1x 3/8-16 x 3.50" screw & 3/8 AN washer. (See Fig. 3-m)



Fig. 3-m: Re-Install Upper Smooth Idler

- N. On the right side of the mounting bracket assembly between the upper & lower smooth idlers, there is a 2.730" spacer secured by a 3/8-16 x 3.50" screw & a 3/8 AN washer. Remove this spacer & hardware & set aside for re-use in a later step. This spacer is temporarily removed to gain better access to 1x of the 5x supercharger mounting screws. (See Fig. 3-n)

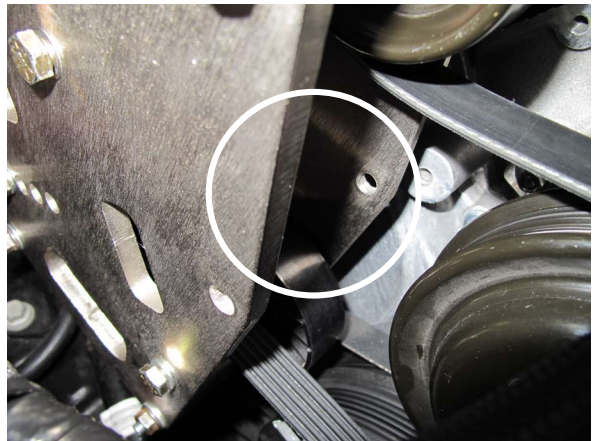

Fig. 3-n: Temporarily Remove Spacer (Circled)

- O. Notice the mounting holes on the front mounting plate. 3x screws can be easily accessed. However, the 2x screws that are circled will require the use of a long 9/16" boxed end wrench for ease of installation. (See Fig. 3-o)

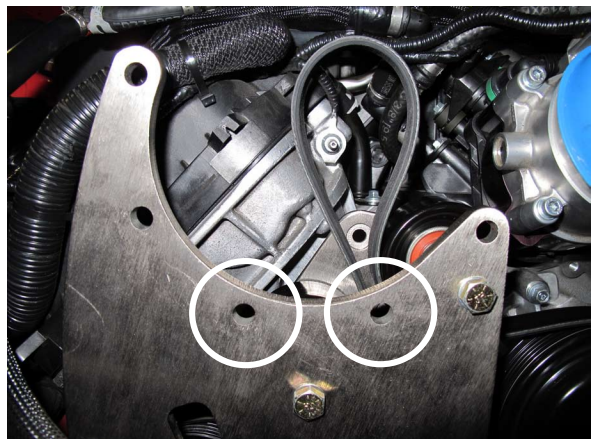

Fig. 3-o: Supercharger Mounting Holes

3. SUPERCHARGER ASSEMBLY PREPARATION & INSTALLATION, cont'd

- P. Prior to installing the supercharger to the mounting bracket assembly, it is suggested that you lubricate the threads in the mounting bosses on the supercharger. To do this, locate the provided 5x 3/8-16 x 1.25" screws, lightly coat the screw threads with lubricant & screw them into the mounting bosses until they bottom out. Once complete, remove the screws from the mounting bosses. This process makes it easier to install the hard to reach supercharger mounting screws. (See Fig. 3-p)

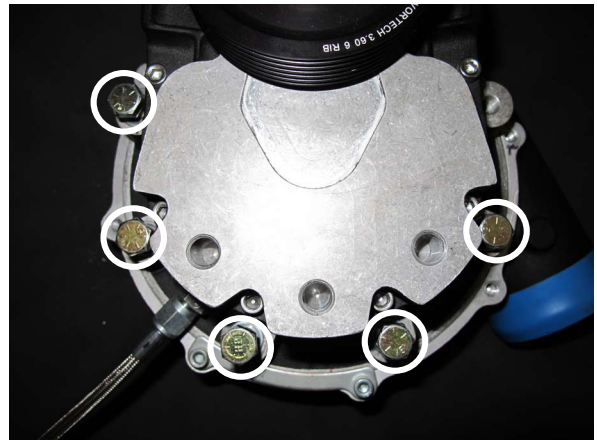

Fig. 3-p: Lubricate Threaded Bosses

- Q. Place the supercharger onto the mounting bracket cradle & begin to thread the 5x 3/8-16 x 1.25" supercharger mounting screws by hand, making sure to use 3/8 AN washers on all 5x screws. Once in position, proceed to tighten all 5x 3/8-16 x 1.25" supercharger mounting screws. (See Fig. 3-q)

NOTE: Engine Oil Fed Units Only: Locate the included length of black braided 1/2" oil drain hose. Remove the shipping cap from the 1/2" barbed oil drain fitting on the bottom of the supercharger and attach the drain hose with the included #8 worm gear clamp. For oil feed & drain line instructions, proceed to Section 10, then return to Section 4 once complete.



Fig. 3-q: Mount Supercharger To Bracket & Secure

- R. With the supercharger secured to the mounting bracket, proceed to re-install the previously removed 2.730" spacer, make sure that the drive belt runs above & below the spacer. Secure with the previously removed 3/8-16 x 3.50" screw & 3/8 AN washer. At this time, proceed to tighten all mounting bracket hardware. (See Fig. 3-r)

NOTE: In some cases, you may need to loosen the 2x 3/8-16 x 3.50" screws securing the upper & lower smooth idler to provide enough room to slide the 2.730" spacer back into its original position.

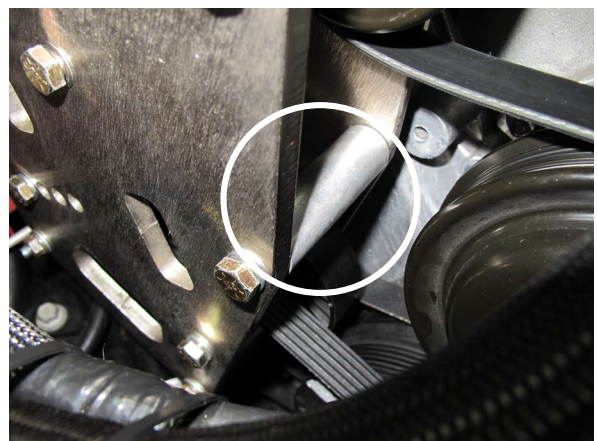

Fig. 3-r: Re-Install Spacer (Circled)

3. SUPERCHARGER ASSEMBLY PREPARATION & INSTALLATION, cont'd

- S. Use the Belt Routing Diagram (Fig. 3.2) on Pg. 20 to route the new drive belt. Once in position, use a 15mm wrench to rotate the belt tensioner counter-clockwise, then slide the new drive belt over the smooth idler on the tensioner. Once the belt is in position & properly routed, release the tension on the belt tensioner.

(See Fig. 3-s)

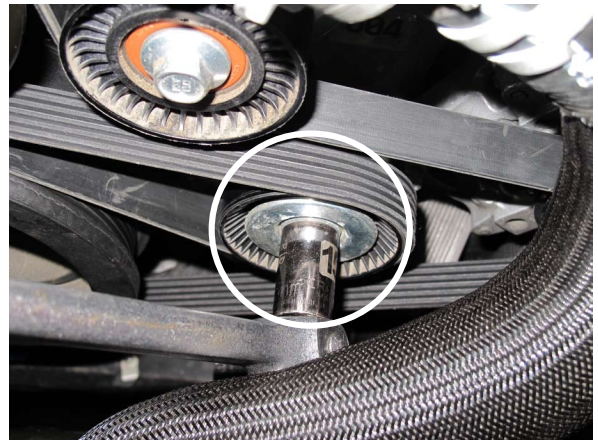

Fig. 3-s: Route Drive Belt

- T. Locate the supplied 1.00" black anodized aluminum throttle body spacer. Install the included large O-ring into the groove in the spacer. This O-ring seals against the throttle body and the smooth side of the spacer seals against the OEM O-ring in the intake manifold.

(See Fig. 3-t)



Fig. 3-t: Place O-Ring In Anodized Spacer

- U. Ensure that both O-ring seals stay in place & install the spacer using the supplied 4x M6 x 30mm button-head screws & 4x 6mm washers.

(See Fig. 3-u)



Fig. 3-u: Clean T-Body Flange & Verify O-Ring Placement

3. SUPERCHARGER ASSEMBLY PREPARATION & INSTALLATION, cont'd

- V. Mount the throttle body to the throttle body spacer using the 4x M6 x 35mm screws & 4x 6mm washers. The throttle body connector must be facing the drivers side of the vehicle in order to clear the mounting bracket. Carefully snip the strip of tape securing the throttle body electrical harness to the connector housing. Reconnect the connector to the throttle body. Route the large wiring harness near the passenger side valve cover, throttle body electrical harness & any other items away from moving parts and sharp edges and secure.

(See Fig. 3-v)



Fig. 3-v: Re-Install T-Body 180° From Original Orientation

3. SUPERCHARGER ASSEMBLY PREPARATION & INSTALLATION, cont'd

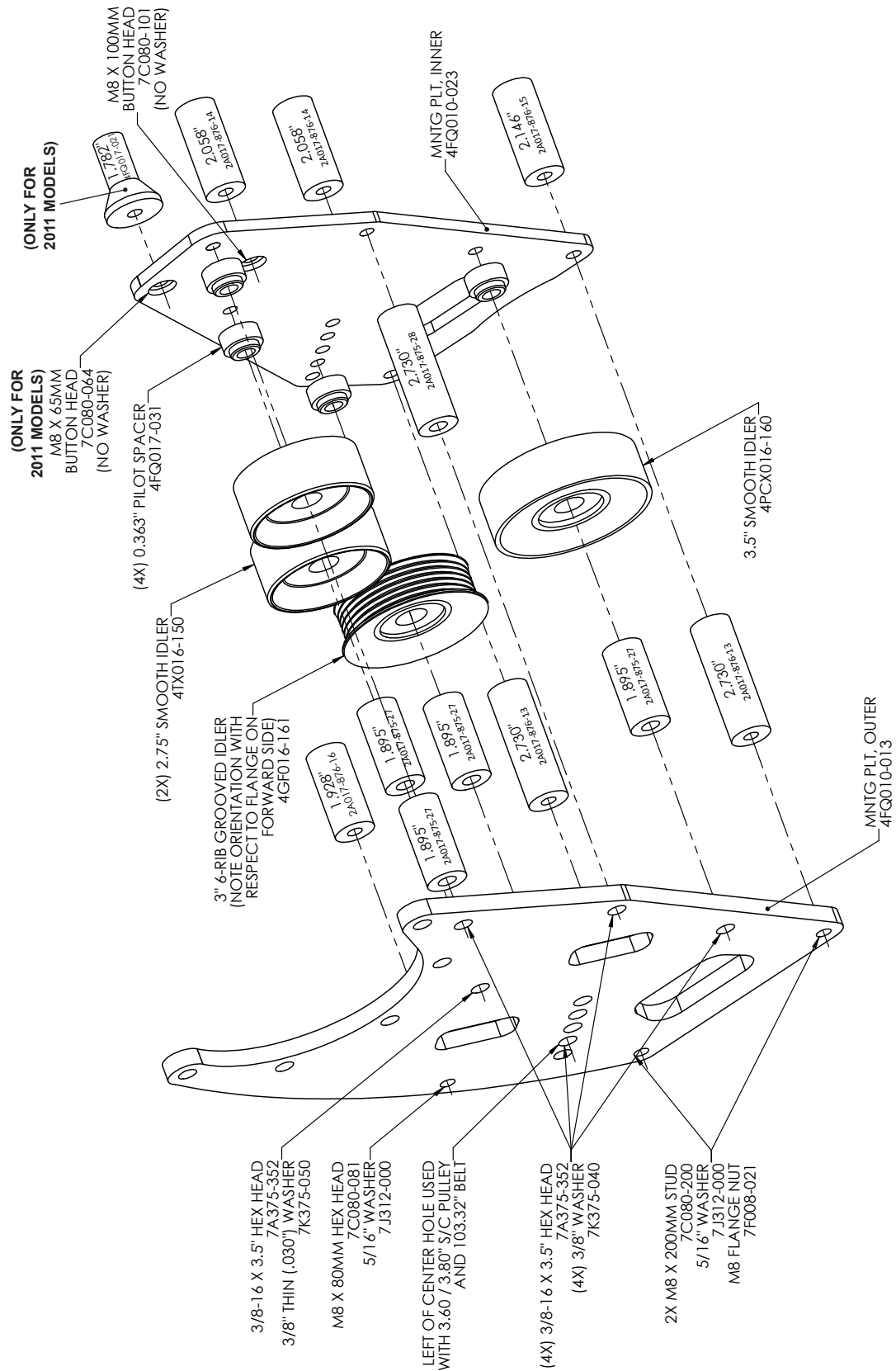

FIG 3.1 - MOUNTING BRACKET ASSEMBLY DIAGRAM

3. SUPERCHARGER ASSEMBLY PREPARATION & INSTALLATION, cont'd

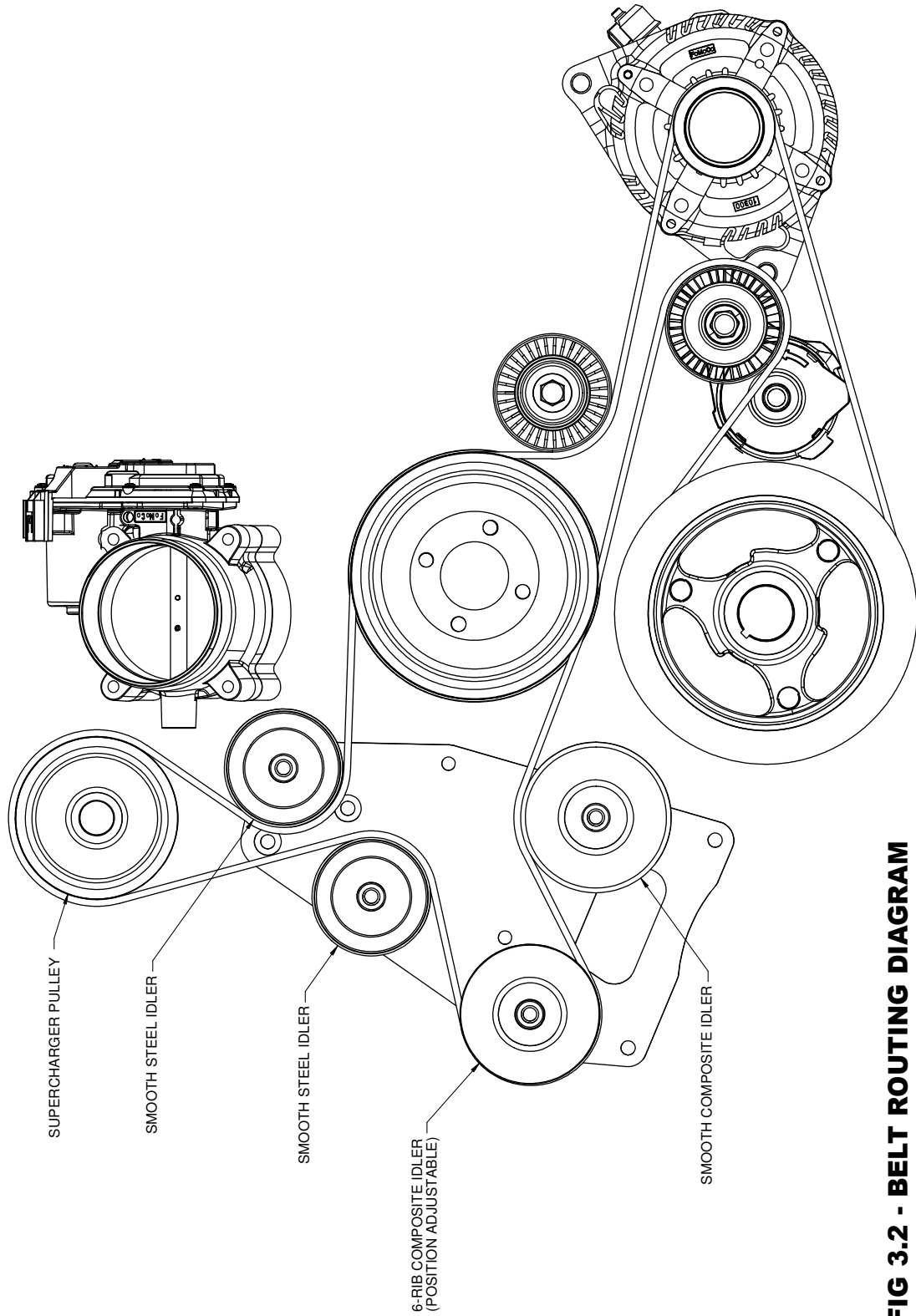

FIG 3.2 - BELT ROUTING DIAGRAM

4. PCV SYSTEM MODIFICATION

- A. Use a razor blade to carefully slit each end of the plastic tube until it can be split away from the barbed fittings inside. Take care not to damage the fittings.

(See Fig. 4-a)



Fig. 4-a: OEM Passenger Side PCV Hose (Fittings Removed)

- B. Locate the supplied PCV valve, 5/8" to 3/8" brass reducer, 90° 5/8" fitting, 5/8" hose & 3/8" hose. Assemble the passenger side breather assembly as shown. Note that the hose lengths are called out in Fig. 4-b. The 3/8" hose is secured with 2x #17 stepless clamps. The PCV valve is secured to the 5/8" hose using 1x #28.6 stepless clamps while the remaining 5/8" fittings are secured using #25.6 stepless clamps.

(See Fig. 4-b)

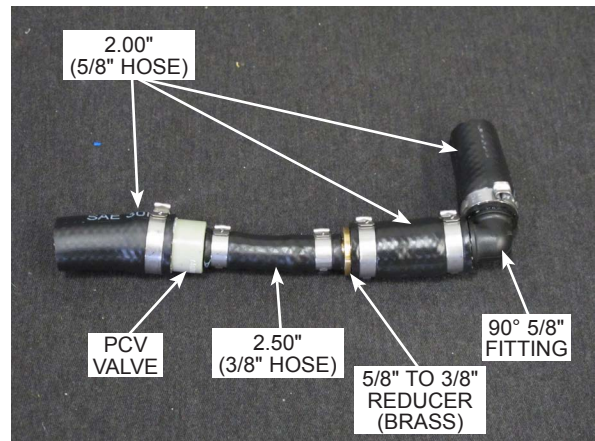

Fig. 4-b: PCV Assembly Layout

- C. Test fit the assembly as shown with the 45° quick disconnect fitting installed to the intake manifold. Clock the assembly as needed for clearance to the supercharger pulley. Once in position, remove the assembly & secure the stepless clamps, then wrap the assembly with the provided flex braid sleeve & shrink wrap.

(See Fig. 4-c)

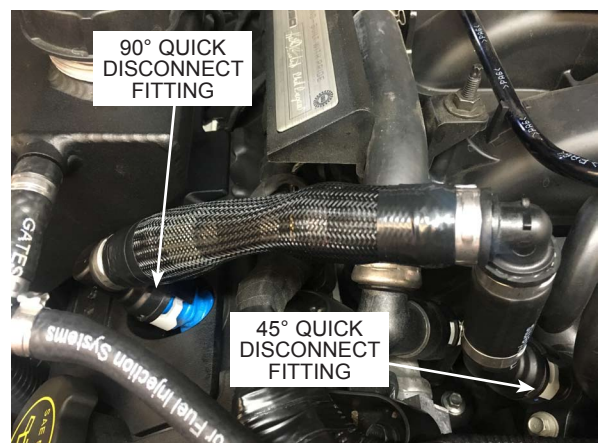

Fig. 4-c: Modified Passenger Side PCV Hose

This page was left intentionally blank.

5. CHARGE AIR COOLER & DISCHARGE TUBE INSTALLATION

- A. Remove the 4x 13mm-headed screws & 4x 13mm-headed nuts securing the front braces to the upper radiator support & back side of the front bumper support.
(See Fig. 5-a)



Fig. 5-a: Remove Front Braces

- B. Back out the 4x inner-most screws of the bumper support, leaving about 1/2" of the screw protruding from the back side. Raise the cooler into position, making sure to align the cooler brackets to the 4x screws previously backed out. Once aligned, begin to thread the screws through the cooler brackets. Proceed to re-install the previously removed front braces, making sure the cooler bracket is sandwiched between the lower brace mounts & bumper support. Route the wire harness along the top side of the bumper support.
(See Fig. 5-b)

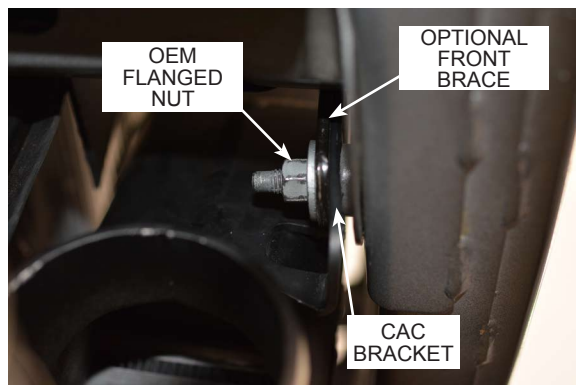

Fig. 5-b: CAC Mounting Order

- C. Cut off the entire lower section of the radiator shroud, leaving only the mount for the ambient air temperature sensor.
(See Fig. 5-c)

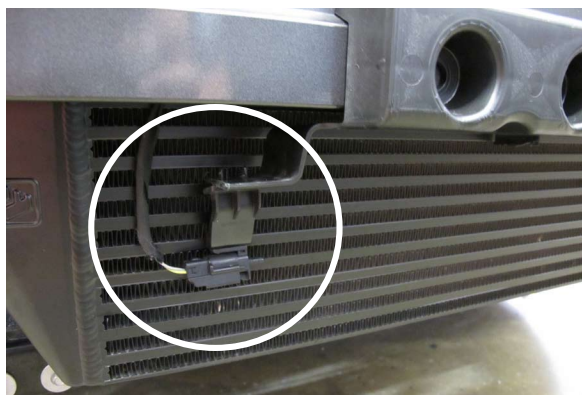

Fig. 5-c: Modified Lower Shroud Section

5. CHARGE AIR COOLER & DISCHARGE TUBE INSTALLATION, cont'd

- D. The upper section of the radiator shroud will need to be modified in order to clear the charge air cooler and wiring harness that runs along the top of the front bumper support. Trim away as necessary, periodically test fitting the radiator shroud for proper fitment.
(See Fig. 5-d)

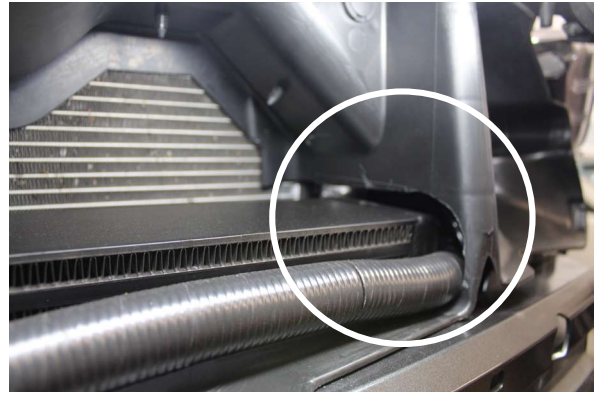

Fig. 5-d: Modified Upper Shroud Section

- E. With the radiator shroud sufficiently trimmed, re-attach it to the vehicle using 3x of the previously removed plastic fasteners & 2x of the previously removed 10mm-headed fasteners.
(See Fig. 5-e)



Fig. 5-e: Modified Radiator Shroud

- F. In order to make room for Tube B, you will need to modify the passenger side of the carbon composite core support. Install a straight 3" silicone sleeve & two #48 hose clamps to the passenger side of the cooler. Temporarily install a 3" silicone bump sleeve to the end of Tube B with the smaller bend. Mock up Tube B & you will see where you need to trim. Use Fig. 5-f as a visual aid & trim accordingly.
(See Fig. 5-f)

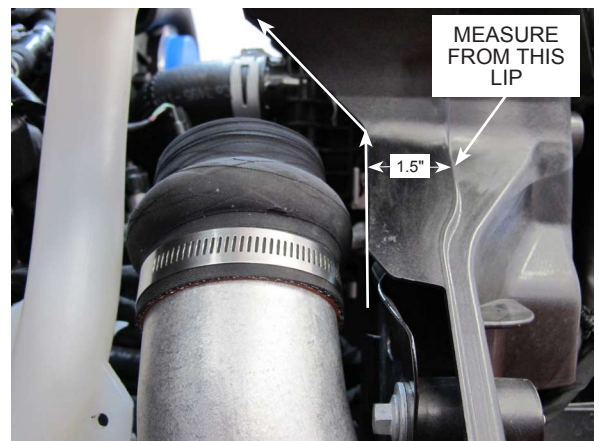

Fig. 5-f: Modified Radiator Support (After Modification)

5. CHARGE AIR COOLER & DISCHARGE TUBE INSTALLATION, cont'd

- G. Install the 3.00"-2.75" silicone bump reducer sleeve to the volute. The volute end of the sleeve uses a #44 hose clamp, while the tube end uses a #48 hose clamp. Install Tube A & clock it accordingly.

(See Fig. 5-g)

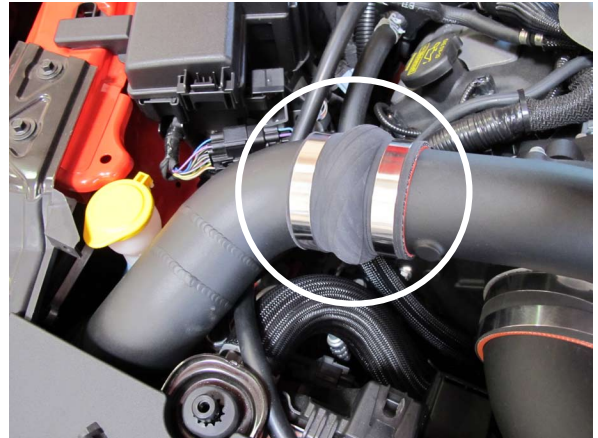

Fig. 5-g: Tube A Installation

- H. With the carbon composite core support modified, install a 3" silicone bump sleeve & two #48 hose clamps to the end of Tube B with the smaller bend. Slide the open end of Tube B into the silicone coupler on the cooler. Slide the other end of Tube B into Tube A. For proper clearance between the body of the vehicle & the windshield washer reservoir, you will need to bend the steel tab, closest to the bypass valve flange, towards the front of the vehicle.

(See Fig. 5-h)

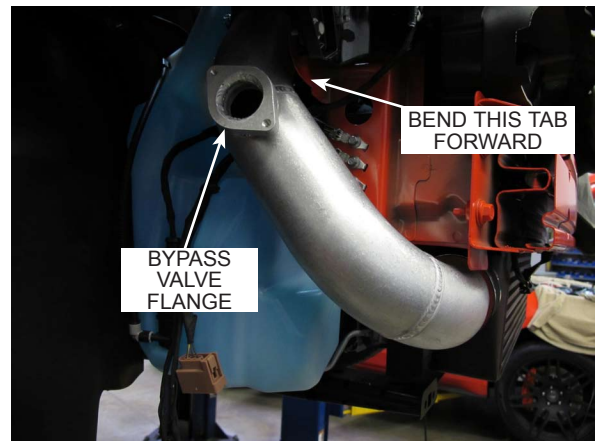

Fig. 5-h: Tube B Installation

- I. With tubes A & B in place, attach the bypass valve with the supplied hardware & gasket to the bypass valve flange on Tube B. Make sure that the opening of the bypass valve is facing towards the back of the vehicle. Once secured, attach the supplied filter to the bypass valve & tighten the supplied hose clamp.

(See Fig. 5-i)

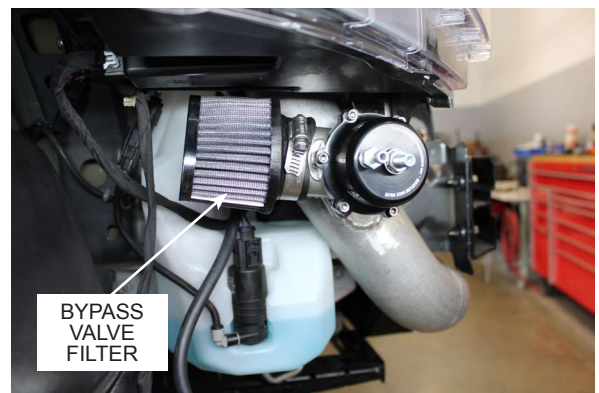

Fig. 5-i: Bypass Valve Mounting

5. CHARGE AIR COOLER & DISCHARGE TUBE INSTALLATION, cont'd

- J. Install the 3.50"-3.00" reducer sleeve to the driver side of the cooler. Secure the cooler end of the reducer sleeve with a #48 hose clamp. Locate Tube C, which has two 90° bends, and slide it into the silicone sleeve on the cooler & secure with a #56 hose clamp. Install a 3.50" silicone sleeve & two #56 hose clamps onto the open end of the Tube C.

(See Fig. 5-j)

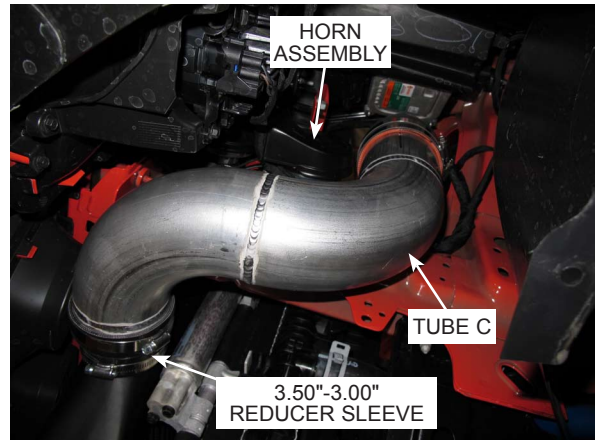

Fig. 5-j: Tube C Installation
(Oil Cooler Removed For Clarity)

- K. Make sure that Tube C is clear of the horn & oil cooler. You may need to relocate the horn wiring harness to keep it from resting against Tube C.

(See Fig. 5-k)

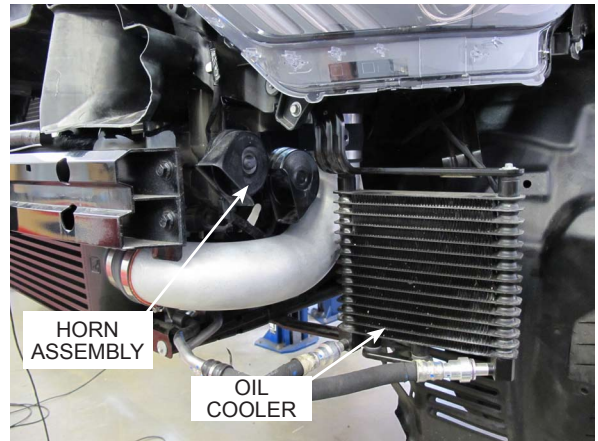

Fig. 5-k: Check Tube C Clearance

- L. Locate Tube D & insert the one end of the tube into the silicone sleeve previously attached on Tube C. Attach the supplied 4.00"-3.50" silicone reducer sleeve & #56 hose clamp to the other end of Tube D, then install the MAF housing. Be sure to have the "FLOW" arrow on the MAF flange facing towards the throttle body.

(See Fig. 5-l)

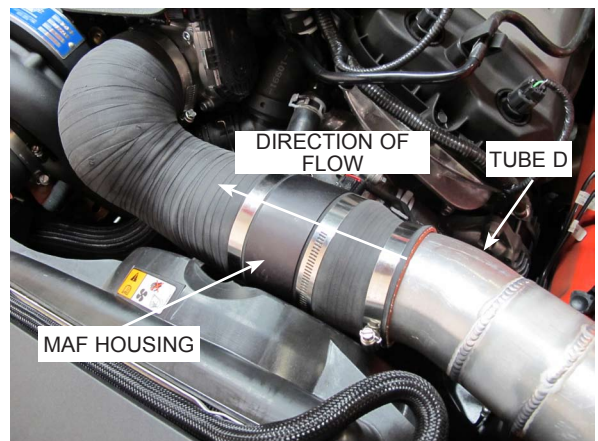

Fig. 5-l: Tube D & MAF Housing Installation

5. CHARGE AIR COOLER & DISCHARGE TUBE INSTALLATION, cont'd

- M. Attach the throttle body sleeve & #56 hose clamp to the throttle body, then attach the other end of the sleeve to the MAF housing. Use #64 hose clamps to secure the MAF housing. Once in place, insert the MAF sensor into the flange & secure with the provided M4-.7 x 8mm screws. Connect the MAF plug to the sensor. Verify that all tubes are free of any obstructions then proceed to tighten all of the hose clamps.

(See Fig. 5-m)

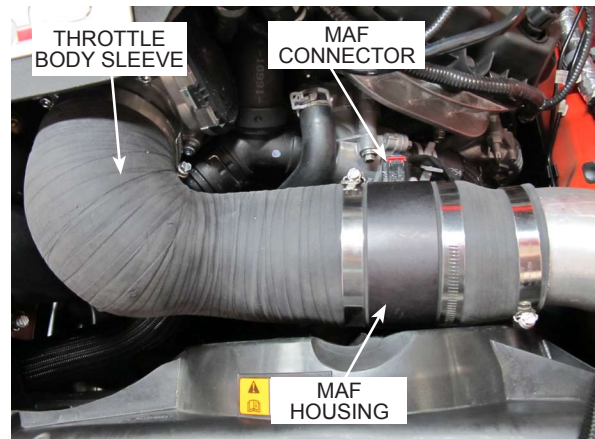

Fig. 5-m: Throttle Body Sleeve Installation

- N. Remove the plastic push pins securing the brake cooling ducts to the front bumper cover. These will not be reused.

(See Fig. 5-n)



Fig. 5-n: Remove Brake Cooling Ducts

- O. Remove the three 3x 7mm-headed fasteners securing the oil cooler duct to the front bumper cover. This will not be reused. With the necessary ducting removed, test fit the front bumper cover to the vehicle, check for any clearance issues & adjust as necessary.

(See Fig. 5-o)



Fig. 5-o: Remove Oil Cooler Duct

This page was left intentionally blank.

6. FUEL INJECTOR REPLACEMENT

- A. Disconnect the fuel feed line from the fitting near the driver side fuel rail.

(See Fig. 6-a)

NOTE: The fuel line may be pressurized.
Take care to avoid spray and spills.

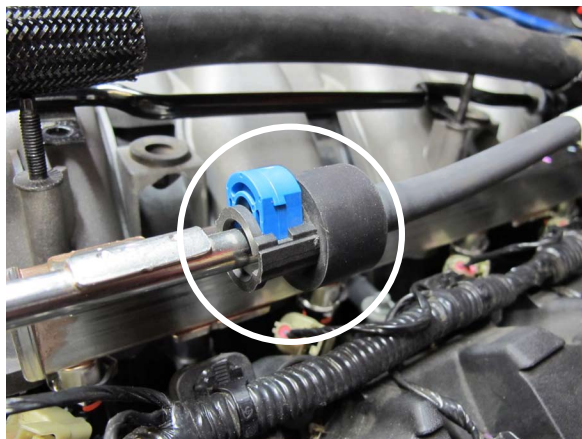

Fig. 6-a: Disconnect Fuel Feed Line

- B. Remove the 4x 10mm hex nuts securing the plastic heater hose guides and set the guides aside for later reinstallation. Reposition the vacuum tube assembly mounted under the driver side heater hose guide to facilitate fuel rail removal. Remove the foam insulation from each fuel rail (2x pieces total). Unplug each of the 8x fuel injector electrical connectors.

(See Fig. 6-b)



Fig. 6-b: Hose Guide Removal

- C. Unplug the fuel pressure sensor from the drivers side of the fuel rail. Remove the 4x 10mm-headed screws securing the fuel rails to the intake manifold (2x per side). Lift the fuel rails (with injectors attached) up and away from the engine, taking care not to spill fuel from the feed fitting. Drain the fuel from the rails.

(See Fig. 6-c)



Fig. 6-c: Remove Fuel injector Rail Assembly

6. FUEL INJECTOR REPLACEMENT, cont'd

- D. Note the orientation of the OEM injectors in the fuel rails. Disengage the retaining clips and remove the OEM injectors. Install the supplied high-flow injectors into the fuel rails in the same orientation as the OEM injectors and secure in the original fashion with the OEM retaining clips.
(See Fig. 6-d)



Fig. 6-d: Fuel Rail / Injector Assembly Detail

- E. Install the rail/injector assembly into the intake manifold. Secure the fuel rails with the previously removed 10mm-headed screws. Connect the fuel injector electrical connectors to each of the 8x injectors. Place the foam insulation back over each fuel rail. Place the vacuum tube assembly back into position on the studs near the driver side fuel rail. Reinstall the plastic heater hose guides and secure with the OEM 10mm hex nuts. Route the heater hoses over them in the OEM fashion. Reconnect the fuel feed line to the fitting on the fuel rail assembly. Make sure it is securely connected in the OEM fashion.
(See Fig. 6-e)

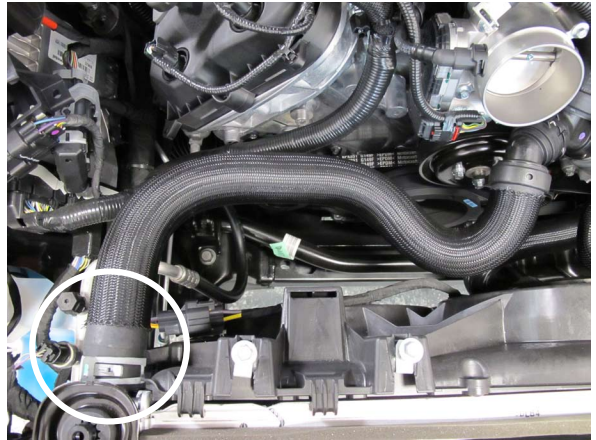

Fig. 6-e: Re-securing Fuel Rails

7. ENGINE COOLING SYSTEM MODIFICATION

- A. Locate the previously-removed OEM upper radiator hose. Remove the factory spring clamp & set aside. Cut off 2" from the end of the hose.

(See Fig. 7-a)



*Fig. 7-a: Upper Radiator Hose
(OEM Configuration)*

- B. Cut away the OEM plastic hose clamp on the quick-release end of the radiator hose, taking care not to damage the hose. Separate the hose from the quick-release fitting, then cut 1" off of the end of the hose.

(See Fig. 7-b)



Fig. 7-b: Cut Plastic Hose Clamp

- C. The upper radiator hose will need to be flipped when re-installed on the vehicle in order to provide adequate space between the upper radiator hose & the supercharger. The end of the hose originally attached to the quick-release fitting will now be attached to the upper radiator inlet. The opposite end will now be attached to the quick-release fitting.

(See Fig. 7-c)



*Fig. 7-c: Upper Radiator Hose
(New Configuration)*

7. ENGINE COOLING SYSTEM MODIFICATION, cont'd

- D. Once both ends of the hose are attached & properly clocked, secure the radiator-side of the hose using the previously removed spring clamp. Use the supplied #24 hose clamp on the quick-release side of the hose.

(See Fig. 7-d)

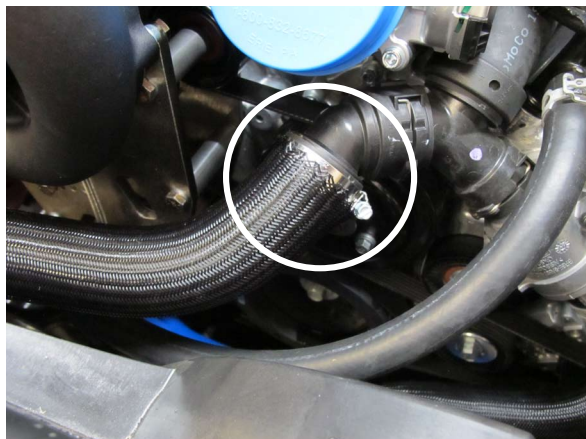

Fig. 7-d: #24 Hose Clamp

- E. To the right of the passenger side shock tower you will see a ground strap for the electric power steering system. Remove the 8mm-headed fastener securing the ground strap & relocate this ground strap to the harness mount directly below the original mounting location for this ground strap. Re-use OEM hardware.

(See Fig. 7-e)

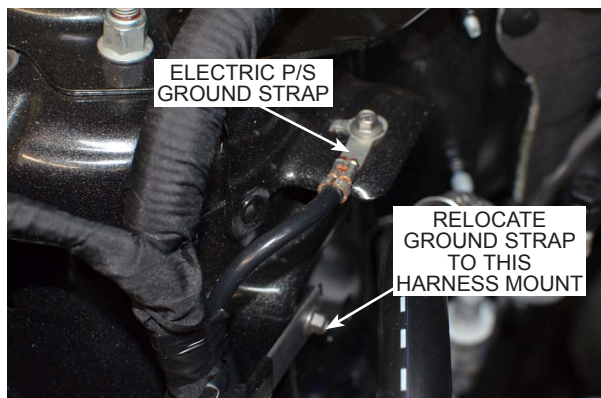

Fig. 7-e: Ground Strap Relocation

- F. Remove the 13mm-headed screw on the brace to the right of the battery & attach the new coolant reservoir as shown.

(See Fig. 7-f)

NOTE: Base model vehicles will need to modify the section pointed out in Fig. 7-f for proper fitment of the coolant reservoir.

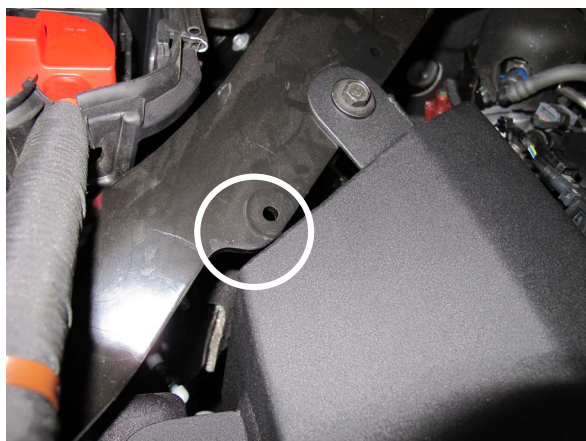

Fig. 7-f: Coolant Reservoir Mount #1

7. ENGINE COOLING SYSTEM MODIFICATION, cont'd

- G. The second mount of the coolant reservoir will be mounted where the electric power steering ground strap was previously attached. Reuse the 8mm-headed fastener to fasten the coolant reservoir. (See Fig. 7-g)



Fig. 7-g: Coolant Reservoir Mount #2

- H. Locate the included 3/8" hose and cut a 2" piece. Install the piece onto the hose barb on the replacement coolant reservoir and secure with an included #17 stepless clamp. (See Fig. 7-h)



Fig. 7-h: Ø3/8" x 2" Hose

- I. Slide another #17 stepless clamp onto the 2" piece and then insert the black plastic TEE as shown, so one leg points forward and one points to the driver side. Secure with the #17 stepless clamp. (See Fig. 7-i)



Fig. 7-i: Ø3/8" x 2" Hose + 3/8" Tee

7. ENGINE COOLING SYSTEM MODIFICATION, cont'd

- J. Locate the small coolant hose running from the driver side front of the engine previously disconnected from the OEM coolant reservoir. Cut off the molded bends of the hose.

(See Fig. 7-j)



Fig. 7-j: Small Coolant Hose

- K. Use the included 5/16" hose, 5/16" barbed hose unions, and #15.7 stepless clamps to extend the upper coolant hose along the top of the engine. Route the hose under the large wiring harness and secure away from moving parts and sharp edges. Trim to length and secure the hose to the plastic TEE using the #15.7 stepless clamps.

(See Fig. 7-k)



Fig. 7-k: Small Coolant Hose

- L. Locate the coolant overflow hose running along the top of the radiator (previously disconnected from the OEM coolant reservoir). Pull back the abrasion sleeve and cut off the molded elbows of the hose. Use the included 3/8" hose, 3/8" barbed hose union, and #17 stepless clamps to extend the coolant overflow hose along the top of the radiator, under discharge tube and around to the area of the replacement coolant reservoir. Secure using #17 stepless clamps.

(See Fig. 7-l)

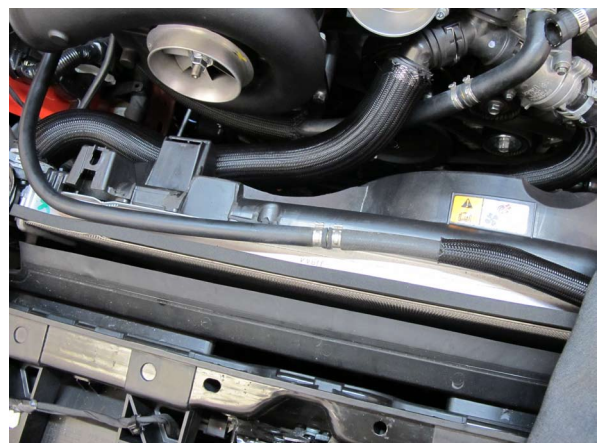

Fig. 7-l: Coolant Overflow Hose Cut & Splice

7. ENGINE COOLING SYSTEM MODIFICATION, cont'd

- M. Trim the 3/8" hose to length & secure it to the plastic TEE using a #17 stepless clamp.
(See Fig. 7-m)

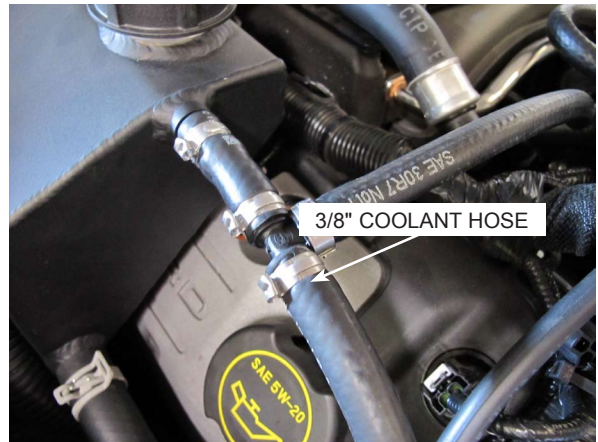

Fig. 7-m: Coolant Overflow Hose

- N. Locate the provided 3/4" 90° hose elbow, 3/4" brass hose union & 2x 28.6 stepless clamps. Slide the hose union into one end of the hose elbow & the other end into the length of provided 3/4" hose. Use the 2x 28.6 stepless clamps to secure the hoses to the brass hose union. Attach the other end of the hose elbow to the drivers side heater tube & secure with the OEM hose clamp.
(See Fig. 7-n)



Fig. 7-n: 3/4" 90° Hose Elbow

- O. Route the open end of the new 3/4" coolant hose (with OEM abrasion sleeve attached) across the front of the motor & attach to the new coolant reservoir on the passenger side. Use zip ties to secure the 3/4" coolant hose to the upper radiator hose.
(See Fig. 7-o)



Fig. 7-o: 3/4" Coolant Hose Routing

7. ENGINE COOLING SYSTEM MODIFICATION, cont'd

- P. Attach the provided length of 7/64 rubber hose to the brass fitting next to the threaded bung & route it towards the bottom of the vehicle. Refill the engine cooling system via the replacement coolant reservoir with the previously-drained coolant. Filter if needed, ensuring no contaminants enter the cooling system. The coolant reservoir should be approximately 1/2 full. Do not overfill. Close the reservoir with the OEM cap from the OEM coolant reservoir.

(See Fig. 7-p)

NOTE: Periodically check the coolant level once the car is running & the cooling system purges.



Fig. 7-p: 3/4" Coolant Reservoir

8. AIR INLET ASSEMBLY INSTALLATION

- A. Directly above the throttle body is a black/yellow dual check valve. Locate the provided check valve & insert it into the 3/8" hose as shown. The check valve is directional & will need to be installed so the flow arrow is pointing towards the yellow OEM dual check valve. Secure with the provided 17.0 stepless clamps.

(See Fig. 8-a)

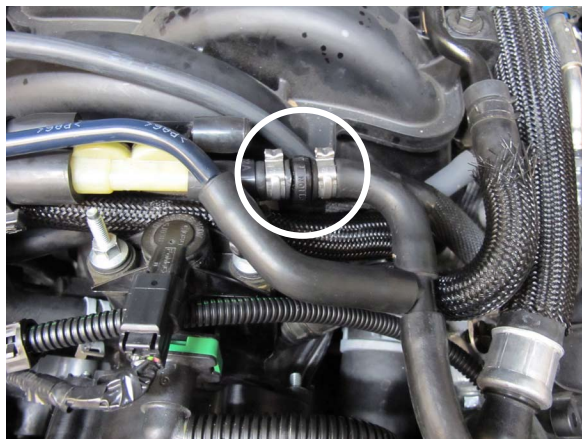

Fig. 8-a: Recirculating IMRC Solenoids

- B. Remove the OEM quick disconnect hose that was attached to the OEM air inlet & connects to the 3/8" tee near the OEM dual check valve. It will not be re-used. Attach a length of 3/8" hose to the remaining leg of the 3/8" tee. Route the hose towards the front of the vehicle & attach the hose to the 3/8" barbed fitting on the supplied supercharger air inlet.

(See Fig. 8-b)

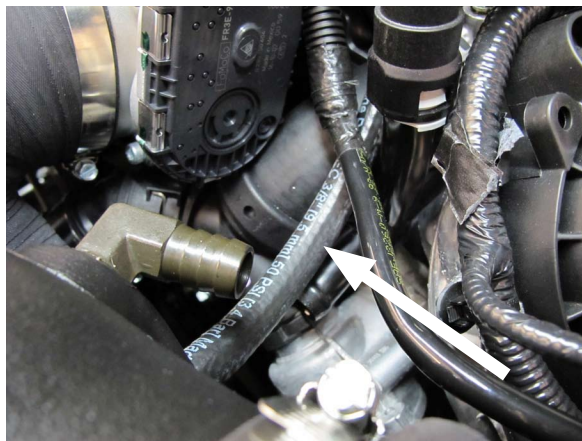

Fig. 8-b: 3/8" Hose From Tee To 3/8" Air Inlet Barb

- C. Locate the provided 5/8" hose & cut an 11" length. Locate the OEM drivers side breather hose & remove the 90° quick release connector from the hose. Insert the quick release connector into the 5/8" hose, then attach the other end of the hose to the 5/8" barbed fitting on the supplied supercharger air inlet. Secure using 2x 25.6 stepless clamps.

(See Fig. 8-c)



Fig. 8-c: 5/8" Breather Hose

8. AIR INLET ASSEMBLY INSTALLATION, cont'd

- D. Use the provided MAF port cover to block off the original location for the MAF sensor. Re-use the OEM hardware & the 2x supplied 6mm washers to secure the MAF port cover.

(See Fig. 8-d)

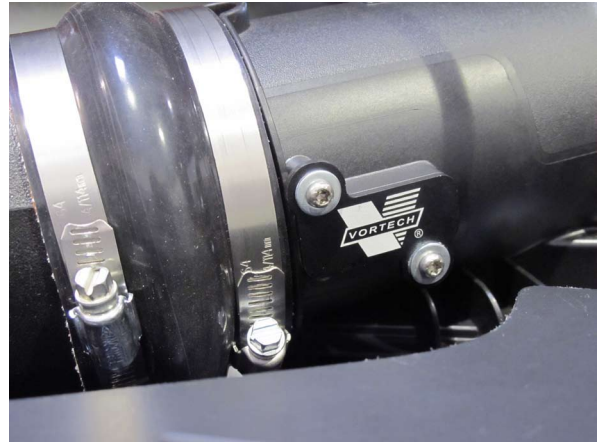

Fig. 8-d: Air Inlet to Airbox Connection; MAF Port Cover

- E. Trimming of the provided OEM air box lid may be required to clear the discharge tube. Trim as necessary, then proceed to install the OEM air box assembly into the vehicle & secure using the factory screw.

(See Fig. 8-e)

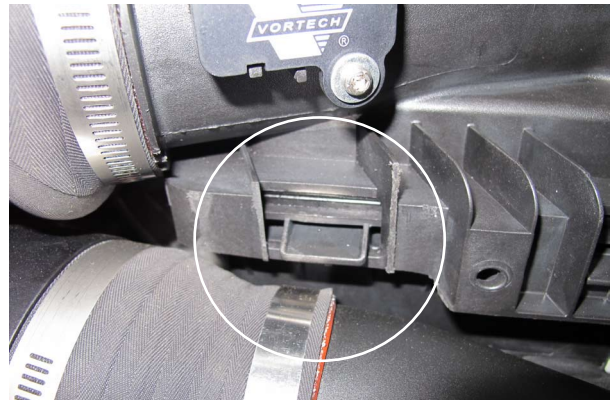

Fig. 8-e: Trimmed Air Box Lid

- F. Connect the inlet duct to the OEM airbox with the Ø4" bump hose. Use the included Ø3.75" x 1" long silicone ring to adapt the airbox fitting up to Ø4" to fit inside the bump hose. Secure with 2x #64 hose clamps.

(See Fig. 8-f)

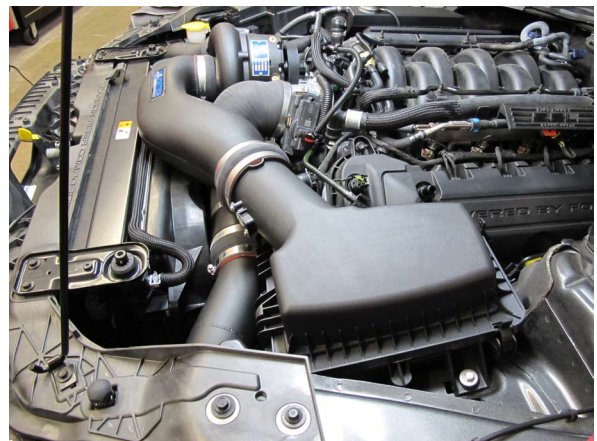

Fig. 8-f: Connect Inlet Duct To Air Box

8. AIR INLET ASSEMBLY INSTALLATION, cont'd

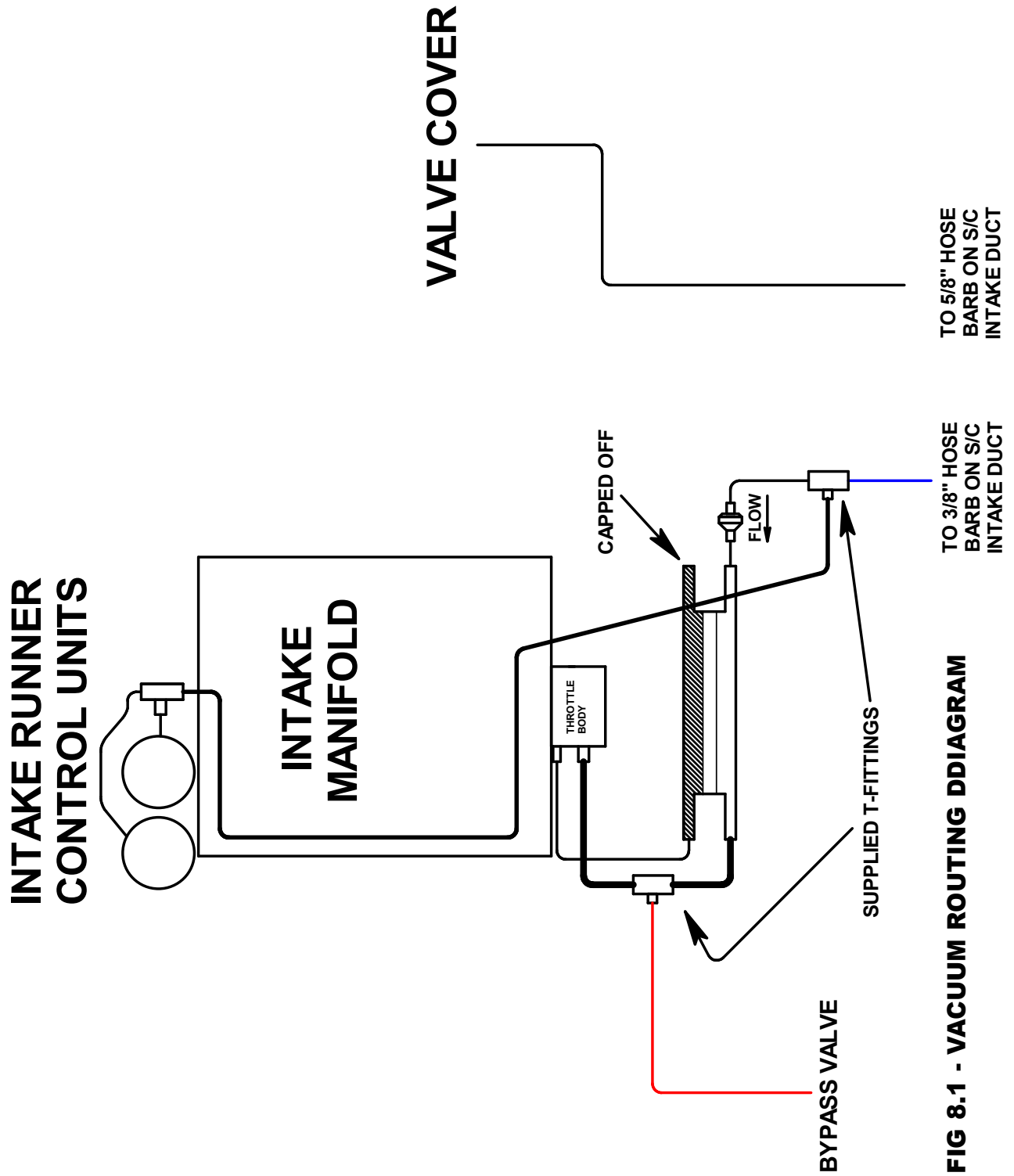

FIG 8.1 - VACUUM ROUTING DDIAGRAM

This page was left intentionally blank.

9. BYPASS VALVE CONNECTION

- A. Locate the supplied vacuum tee fittings & assemble them as shown.
(See Fig. 9-a)



Fig. 9-a: Vacuum Tee Assembly

- B. Cut the OEM vacuum hose shown & insert the vacuum tee as shown. Attach the 7/32-5/32 reducer fitting & short length of 5/32 vacuum hose to the vacuum tee. Locate the supplied 7/32 vacuum hose & attach it to the reducer fitting. Run the vacuum hose along the top of the vehicle, across to the passenger side of the vehicle. Route the vacuum hose down to the discharge tube with the bypass valve, making sure to avoid damaging the hose. Use the supplied zip ties to secure the vacuum hose.
(See Fig. 9-b)

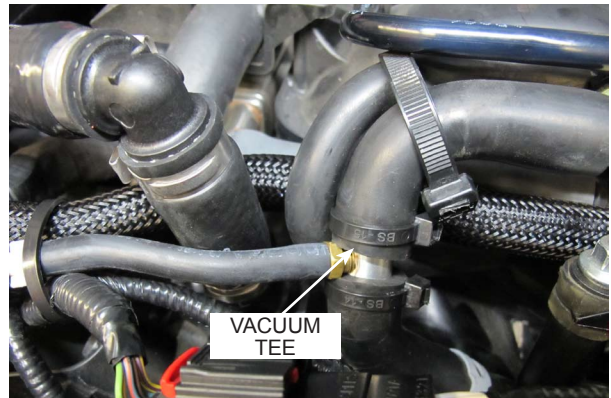

Fig. 9-b: Vacuum Tee Installation

- C. Attach the open end of the 7/32 vacuum hose to the vacuum port on located on the top of the bypass valve. Trim the hose as needed.
(See Fig. 9-c)

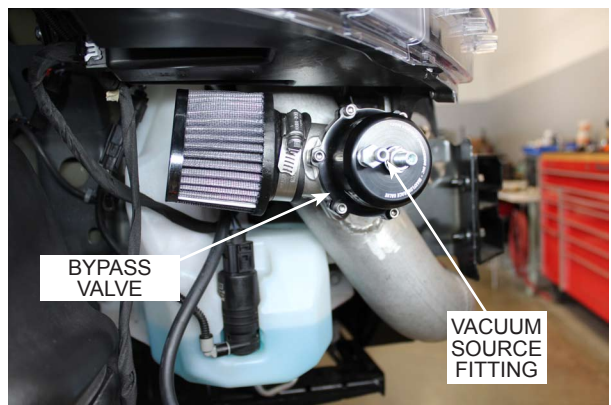

Fig. 9-c: Attach Vacuum Hose To Bypass Valve

9. BYPASS VALVE CONNECTION, cont'd

- D. Verify that all hose clamps & hardware securing the charge cooler to the vehicle are secured, then proceed to re-install the front bumper cover & any panels that have been removed & secure with the proper fasteners.

(See Fig. 9-d)



Fig. 9-d: Re-Install Front Bumper Cover & All Panels

10. WINDSHIELD WASHER RESERVOIR MODIFICATION

- A. Place an empty bin under the windshield washer reservoir & remove the pump from the reservoir by lifting the pump upwards & away from the reservoir. Once the windshield washer fluid has drained, remove the reservoir from the vehicle by removing the (3) 10mm-headed fasteners & wiring harnesses attached to the reservoir.
(See Fig. 10-a)

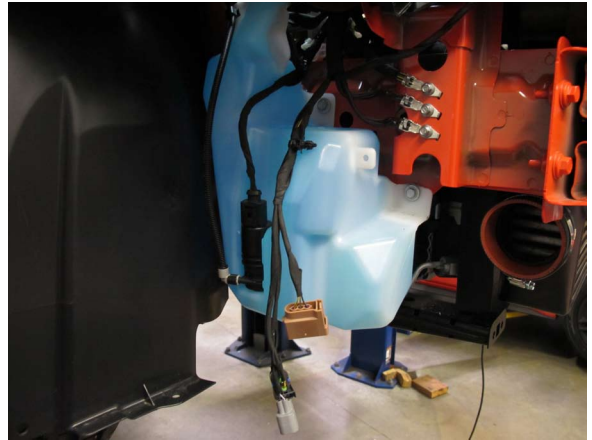

Fig. 10-a: Remove Windshield Washer Reservoir

- B. Remove the 10mm-headed fastener securing the transmission cooler lines to the support mount on the passenger side of the radiator.
(See Fig. 10-b)



Fig. 10-b: Remove Transmission Cooler Lines From Mount

- C. Pull the transmission cooler lines away from their mount, then remove the mount by removing the 10mm-headed fastener securing it to the passenger side of the radiator. The mount & fasteners will not be re-used.
(See Fig. 10-c)



Fig. 10-c: Remove Transmission Cooler Lines Mount From Radiator

10. WINDSHIELD WASHER RESERVOIR MODIFICATION, cont'd

- D. Locate the provided zip tie & secure the transmission cooler lines to the neighboring A/C line. Be sure the zip tie wraps around the rubber isolator. (See Fig. 10-d)

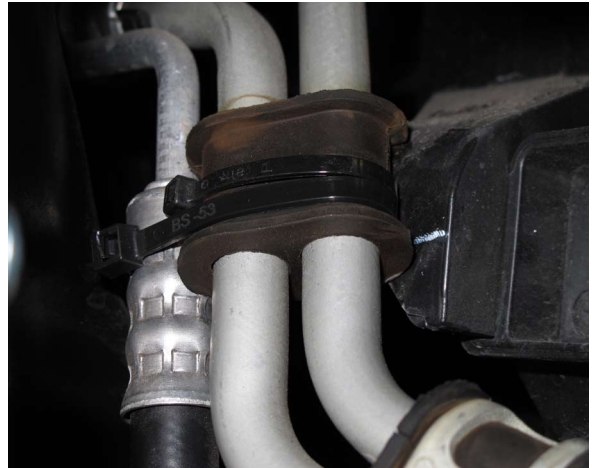

Fig. 10-d: Secure Transmission Cooler Lines To A/C Line via Rubber Isolator

- E. Located on the passenger side of the carbon-composite core support is a tab that's protruding upwards. The backside of the tab has a stepped lip that needs to be smoothed down in order to mount the remote fill reservoir. Use a file or a drum sander to carefully smooth out the lip. Once smooth, use the "narrow" section of the bracket as a drill template & mark 2x holes on the protruding tab. Using a 1/4 drill bit, drill out the 2x holes. These will be used to mount the remote fill reservoir bracket. (See Fig. 10-e)

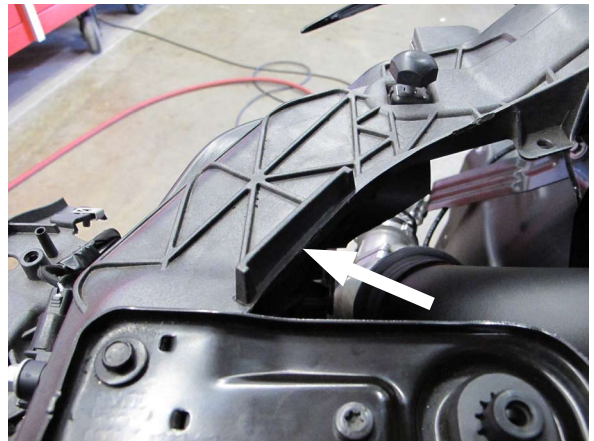

Fig. 10-e: Smooth Out Stepped Lip

- F. Locate the remote fill reservoir & mount it to the "wide" end of the remote fill bracket using the provided 2x 1/4-20 x .375 button head screws & 2x 1/4 washers. (See Fig. 10-f)



Fig. 10-f: Mount Remote Fill Reservoir To Remote Fill Bracket

10. WINDSHIELD WASHER RESERVOIR MODIFICATION, cont'd

- G. Using 2x 1/4-20 x .375 button head screws, secure the remote fill reservoir mount to the carbon-composite core support.

(See Fig. 10-g)



Fig. 10-g: Mount Remote Fill Bracket

- H. Locate the 1 foot length of hose & cut it into a 3" section & a 9" section. Use the provided 5/8 90° plastic elbow to mate the 2 lengths of hose & secure using 2x 25.6 stepless clamps. Slide a 25.6 stepless clamp onto the 3" length of hose, then attach the 3" length of hose to the 5/8 brass barb on the windshield washer reservoir, but do not secure the clamp at this time. Attach the provided mounting bracket to the right side of the windshield washer reservoir & secure it using the provided 2x 1/4-20 x .750 screws, 2x 1/4-20 nylock nuts & 4x 1/4 washers. Check to make sure that the windshield washer reservoir has a rubber grommet installed, then proceed to mount the windshield washer pump by sliding it into the grommet & into the windshield washer reservoir.

(See Fig. 10-h)



Fig. 10-h: Assemble Windshield Washer Reservoir As Shown

- I. Locate the 5/16 washer & slide it onto the windshield washer reservoir mounting stud on the vehicle. This washer will act as a spacer.

(See Fig. 10-i)



Fig. 10-i: Install 5/16 Washer To Mounting Stud

10. WINDSHIELD WASHER RESERVOIR MODIFICATION, cont'd

- J. Mount the new windshield washer reservoir assembly to the vehicle using 2 of the 3 OEM mounting locations. The left side of the windshield washer reservoir will use the OEM mounting stud with the previously installed 5/16 washer. Once in position, clock the 5/8 hose towards the remote fill reservoir located at the top of the vehicle.
(See Fig. 10-j)

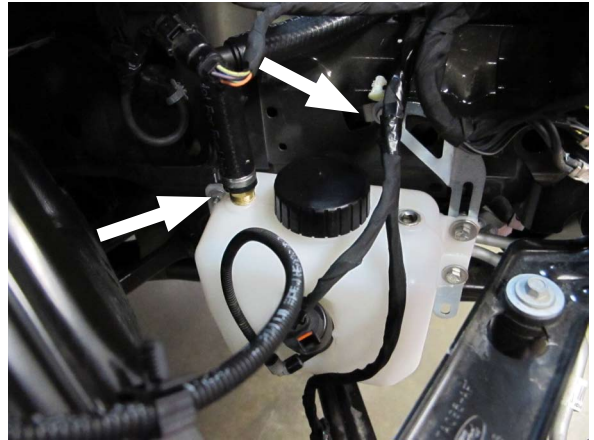

Fig. 10-j: Secure Windshield Washer Reservoir

- K. Route the 9" length of 5/8" hose under Tube A & attach it to the previously installed remote fill reservoir. Secure the hose using the provided #10 hose clamp. At this time, secure the loosely installed 25.6 stepless clamp on the 3" section of 5/8 hose at the windshield washer reservoir.
(See Fig. 10-k)



Fig. 10-k: Secure 5/8 Hose To Remote Fill Reservoir

- L. Re-connect the windshield washer pump & re-attach the nozzle feed hose to the windshield washer pump. Verify that all other hose connections are secure, then slowly begin to fill the windshield washer reservoir from the remote fill reservoir near the top of the vehicle. Only fill it with enough windshield washer fluid to fill the windshield washer reservoir. There should be no windshield washer fluid stored in the remote fill reservoir or the 5/8 hose.
(See Fig. 10-l)



Fig. 10-l: Re-Install Windshield Washer Pump

10. WINDSHIELD WASHER RESERVOIR MODIFICATION, cont'd

- M. Remove the transmission cooler duct from the front bumper cover by removing the 3x 7mm-headed screws. This will not be re-used as it causes an interference with Tube B.
(See Fig. 10-m)



Fig. 10-m: Remove Transmission Cooler Duct

This page was left intentionally blank.

11. REFLASH COMPUTER

IMPORTANT! To ensure trouble-free programming of your vehicle's computer:

- Make sure the vehicle's battery is sufficiently charged.
- Turn off all accessories and close doors to prevent unnecessary drain on the battery.
- Do not attempt to program your vehicle while a battery charger is connected.
- Improper battery voltage will result in failure of the programming process.
- Do not disconnect the cable or turn off the ignition during programming unless prompted to do so.

- Reconnect the battery.
- With the vehicle off, locate the vehicle's OBD2 port located in the lower left hand corner of the dash on the driver side of the vehicle. (See Fig. 11-b) Make sure this connector is seated all the way into the vehicle's OBD2 port. Do not allow this connector to become disconnected during programming or damage may occur to the vehicle's ECM.
- The Reflash tool will power up and display "Program Vehicle". Press ENTER.
- In order to use the SCT Flash tool, you must agree to the terms set forth by SCT Flash. Press ENTER to agree.
- Follow the on-screen prompts to step through the reflash process.
 - When prompted to turn the key on, do so and wait for the vehicle to fully "boot up" When ready, press ENTER.
 - When prompted to "Select Vehicle" select "Mustang GT HO", then press ENTER.
 - The name of the tune being loaded will come up on the screen. Press ENTER.
 - The first phase of the reflash process will now begin.
 - After the process is done finalizing, you will be prompted to turn the key off. Once the key is off, the reflash tool will automatically proceed to the next step.
 - The reflash tool will now prompt you to turn the key on, but do not turn on the engine. Proceed to turn the key to the on position. The reflash tool will automatically proceed to unlock the processor and begin to set it up.
 - Now the reflash tool will begin to load the Vortech tune to your vehicle.
 - When the tune is loaded, the reflash tool will proceed to clear any DTC's.
- The reflash process is now complete. You may unplug the reflash tool from the OBD2 port at this time.



Fig. 11-b: OBD2 Connector and Port



Fig. 11-c: Flash Tool

NOTE: The red dot at the center of the D-Pad on the SCT Flash tool acts as the "ENTER" button.

This page was left intentionally blank.

12. FINAL CHECK

WARNING: Do not attempt to operate the vehicle until all components are installed and all operations are completed including the final check.

- A. If your vehicle has gone over 15,000 miles since its last spark plug change, you will need to change the spark plugs now *before* test driving the vehicle.
- B. Check all fittings, nuts, bolts and clamps for tightness. Pay particular attention to oil and fuel lines around moving parts, sharp edges, and exhaust system parts. Make sure all wires and lines are properly secured with clamps or tie-wraps.
- C. Check all fluid levels, making sure that your tank is filled with 91 octane or higher fuel before commencing test drive.
- D. Start the engine and allow to idle a few minutes, then shut off.
- E. Recheck to be sure that no hoses, wires, etc. are near exhaust headers or moving parts. Look also for any signs of fluid leakage.
- F. **PLEASE TAKE SPECIAL NOTE:** Operating the vehicle without ALL of the subassemblies completely and properly installed may cause **FAILURE OF MAJOR COMPONENTS.**
- G. Test drive the vehicle.
- H. Always listen carefully for engine detonation. Discontinue heavy throttle usage if detonation is heard.
- I. Read the **STREET SUPERCHARGER SYSTEM OWNER'S MANUAL AND RETURN THE WARRANTY REGISTRATION FORM** within thirty (30) days of purchasing your supercharger system to qualify.

For internally lubricated V3 units only

This supercharger has been factory pre-filled with special Vortech synthetic lubricant. Oil does not need to be added to a brand new unit, however a fluid level check should be performed.

Prior to operating the supercharger on the vehicle and after installation onto the vehicle:

Remove the factory installed flat-head brass shipping plug (not the dipstick) from the top of the supercharger case. Replace the sealed shipping plug with the supplied vented plug. Do not operate the supercharger without it. Check the supercharger fluid level using the dipstick as follows:

Fluid level checking procedure:

1. Ensure that the .06" copper sealing washer is located on the dipstick base.
2. Thread the clean dipstick into the unit until it seats.
3. Once the dipstick has seated, remove the dipstick from the unit. Fluid should register in the crosshatched area on the dipstick.
4. **DO NOT OVERFILL!!!** Drain excess fluid from the unit if it is above the maximum level on the dipstick.

Check the fluid level using the dipstick at least every 2,500 miles.

Initial supercharger fluid change must be performed at 2,500 miles. The supercharger fluid must be changed every 7,500 miles maximum thereafter.

Drain the fluid, refill the unit with 4 oz. of Vortech V3 lubricating fluid, and then confirm proper oil level using the dipstick. **DO NOT OVERFILL!!!**

WARNING: Use of any fluid other than the special Vortech lubricant will void the warranty and may cause component failure.



ENGINEERING, INC

1650 Pacific Avenue, Channel Islands, CA 93033-9901 • Phone (805) 247-0226
Fax: (805) 247-0669 • www.vortechsuperchargers.com • M-F 7:00 AM - 3:30 PM (PST)