

# Hybrid Pro 20x20 Modular Island Kit 29

## HP-K-29

Hybrid Pro™ Modular Kit 29 is a modular 20ft x 20ft island exhibit kit that offers many features. The center floor-based display is nearly 8ft tall and 8ft wide and includes three shelves on each side. A lockable door on the side of the center structure allows for accessible and secure storage. Two kiosks are included that offer four sides for graphic messaging, as well as three shelves for small product display. A lightweight pill-shaped fabric structure caps the display for ample branding above eye level.



## features and benefits:

- 12'4" tall island display
- No rigging required
- Center display includes four walls, two pillowcase fabric graphics and two push-fit fabric graphic
- Each kiosk includes four walls, two pillow-case fabric graphics and one push-fit fabric graphics, and three shelves
- Pill shaped top fabric structure is tubular with pillowcase fabric graphics
- Each shelf can hold 15 lbs
- Ships freight

## dimensions:

Hardware

Graphic

Assembled unit:  
279.19" w x 149.96" h x 53.54" d  
7092mm(w) x 3809mm(h) x 1360mm(d)

Refer to related graphic template for more information.

Approximate weight:  
635 lbs / 288 kg

Visit:  
<https://www.theexhibitorshandbook.com/download-graphic-templates>

Shipping

## additional information:

Packing case(s):  
1 FS WOODCRATE  
1 N CRATE

Graphic material:  
Dye-sublimation zipper pillowcase fabric  
Dye-sublimation SEG push-fit fabric

Shipping dimensions:

When included in a larger kit, a different packaging solution will be listed to accommodate all contents of the kit. Individual packaging no longer provided.

FS CRATE  
90" w x 30" h x 36" d  
2286mm(w) x 762mm(h) x 915mm(d)

N CRATE:  
60" l x 57" h x 48" d  
1321mm(l) x 737mm(h) x 381mm(d)

Approximate total shipping weight:  
1008 lbs / 458 kg

### Tabletop Colors:



4 person assembly recommended:



This product may include the following materials for recycle:  
aluminum, select wood, fabric, cardboard, paper, steel, and plastics.

We are continually improving and modifying our product range and reserve the right to vary the specifications without prior notice. All dimensions and weights quoted are approximate and we accept no responsibility for variance. E&OE. See Graphic Templates for graphic bleed specifications.

# Included In Your Kit

Tools, Components, & Connectors



5MM ALLEN T x1

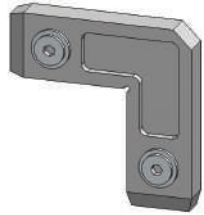

CB9 x16



IB2 x14



PHFC4-1200-L1-MCB9 x8

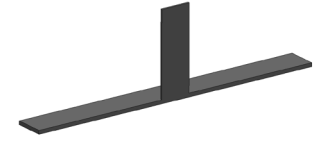

SW-FOOT-500-LN x4



LN114-S2-650 x2



LP-400-1200-L05 x1



LP-CD-400-1200-L05 x1



PH2-600-TG x8



PHFC4-1200-MCB9-MCB9 x4



PM4S3-1200-A315-N x4

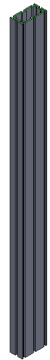

PM4S3-1200-A315-A315 x4

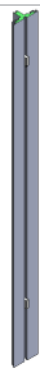

PHFC4-1200-L1-MCB9-SIDE x8



PM4S3-600 x4



TC-50MM-SILVER-ASY-3 x4

# Included In Your Kit

Tools, Components, & Connectors



PH1-1155-L-L1 x4

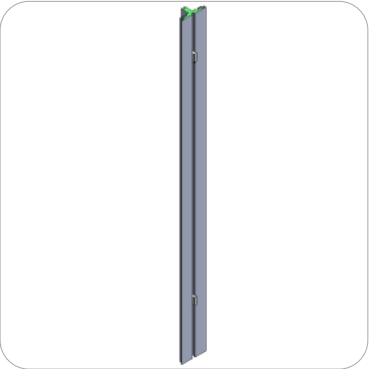

PHFC4-1200-L1-MCB9 x16

# Included In Your Kit



T2 x1



T4 x1

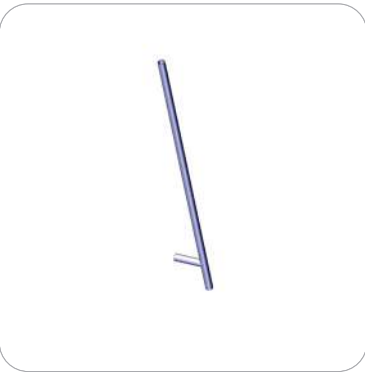

T5 x1

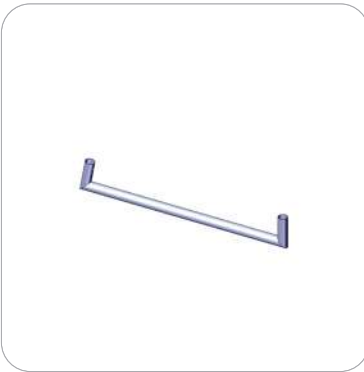

T1 x1

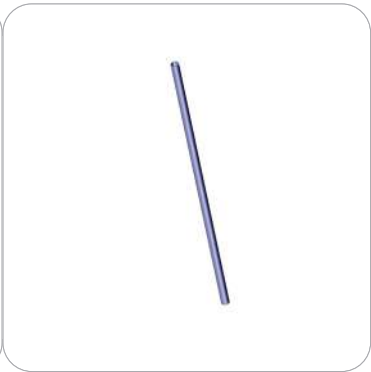

T7 x2



ES30 x7

Tubes HP-FS-7

# Included In Your Kit



T6 x1



T3 x1

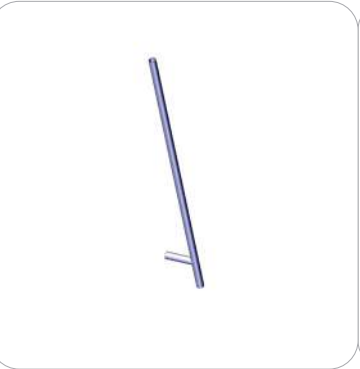

T5 x1

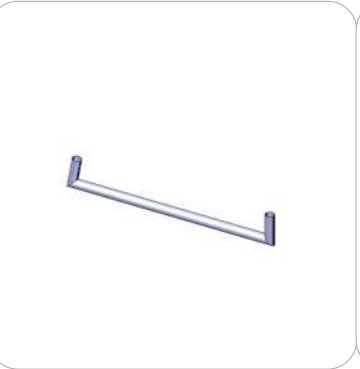

T1 x1



T7 x2

Tubes HP-FS-8



ES30 x7

# Included In Your Kit



T4 x2



T1 x1

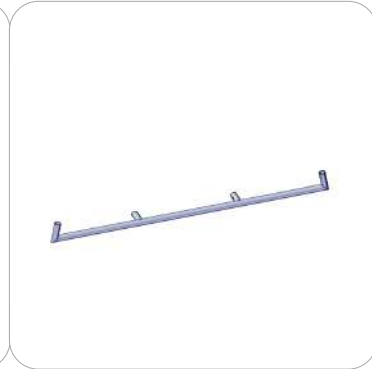

T2 x1



T3 x2

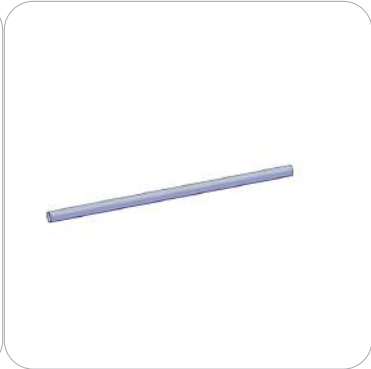

T5 x1



ES30 x8

Tubes HP-FS-9

# Included In Your Kit

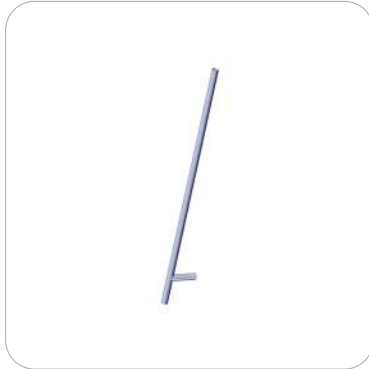

T6 x1

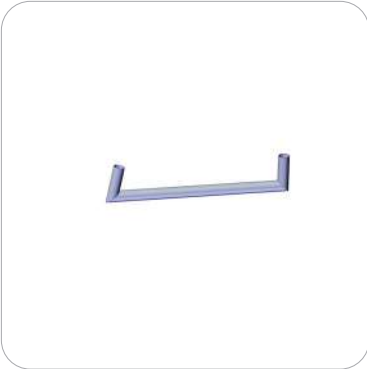

T1 x1



T2 x1

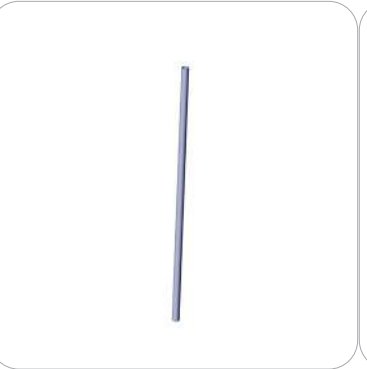

T7 x2



T5 x1

Tubes HP-FS-10



ES30 x7

# Included In Your Kit

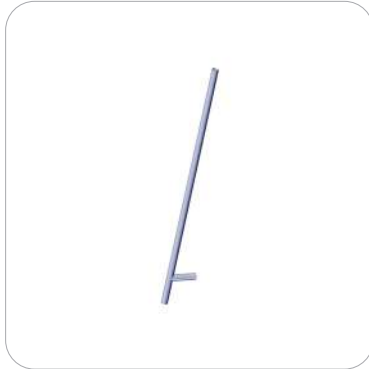

T2 x1

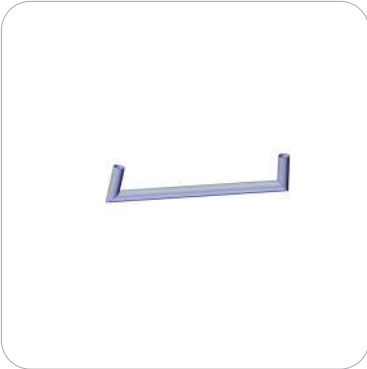

T1 x1



T4 x1

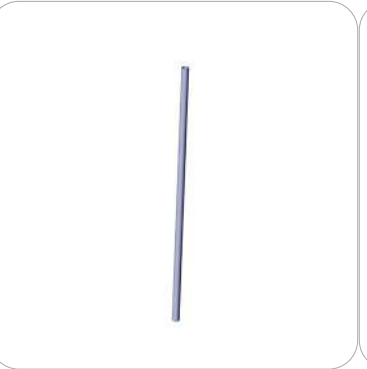

T7 x2



T5 x1

Tubes HP-FS-11

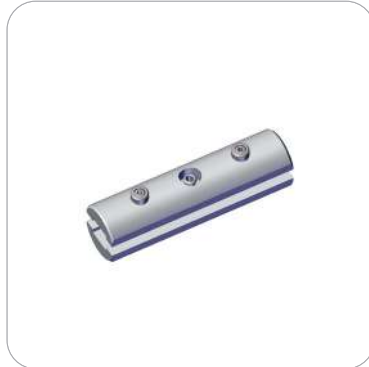

ES30 x7



# Included In Your Kit

Tubes HP-FS-PILL



HP-K-29-T1 x4



HP-K-29-C-T2 x4



HP-K-29-C-T3 x8



HP-K-29-C-T5 x5



HP-K-29-C-T4 x2



HP-K-29-C-T6 x2



HP-K-29-C-T7 x2



ES50 x6















ES30 x4



ES50-C-ES50-S-ASY x8

# Included In Your Kit

					
	HP-29-A2-G x1	HP-29-A1-G x1	HP-29-C3-G x1	HP-29-A3-G x1	HP-29-A4-G x1
Graphics					
	HP-29-C1-G x1	HP-29-A5-G x1	HP-29-B1-G x1	HP-29-B3-G x1	HP-29-B2-G x1
					
	HP-29-C2-G x1	HP-29-D-G x1			

# Exploded Diagram

HP-K-29

-SUGGESTED LAYOUT SECTION 1.1

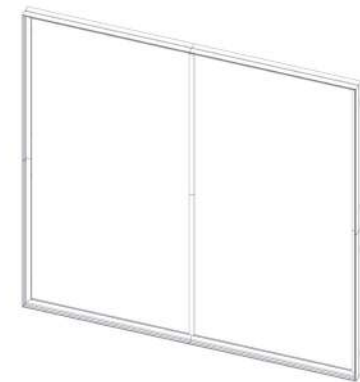
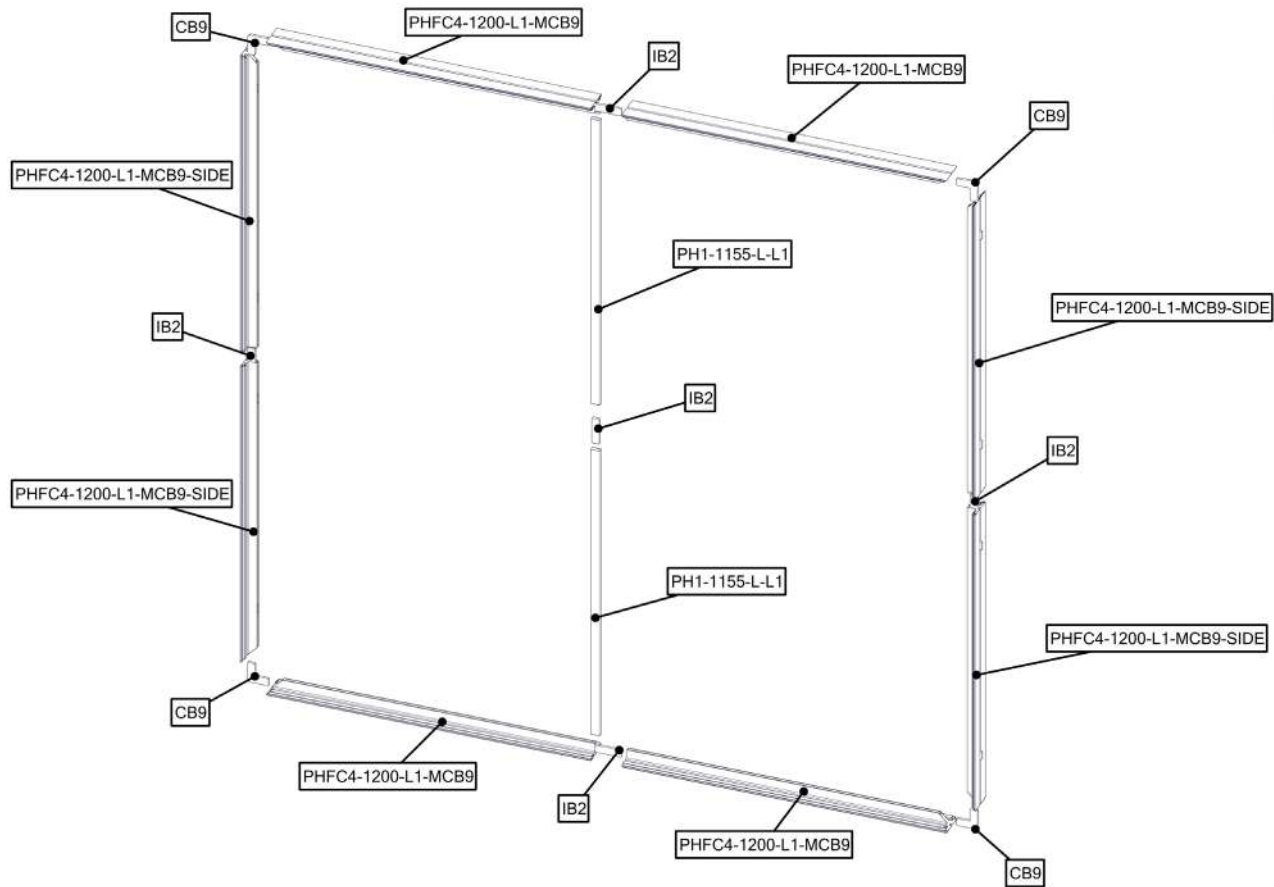

**-ASSEMBLE VECTOR FRAME WITH PH1 SUPPORTS**

# Exploded Diagram

HP-K-29

-SUGGESTED LAYOUT SECTION 1.1

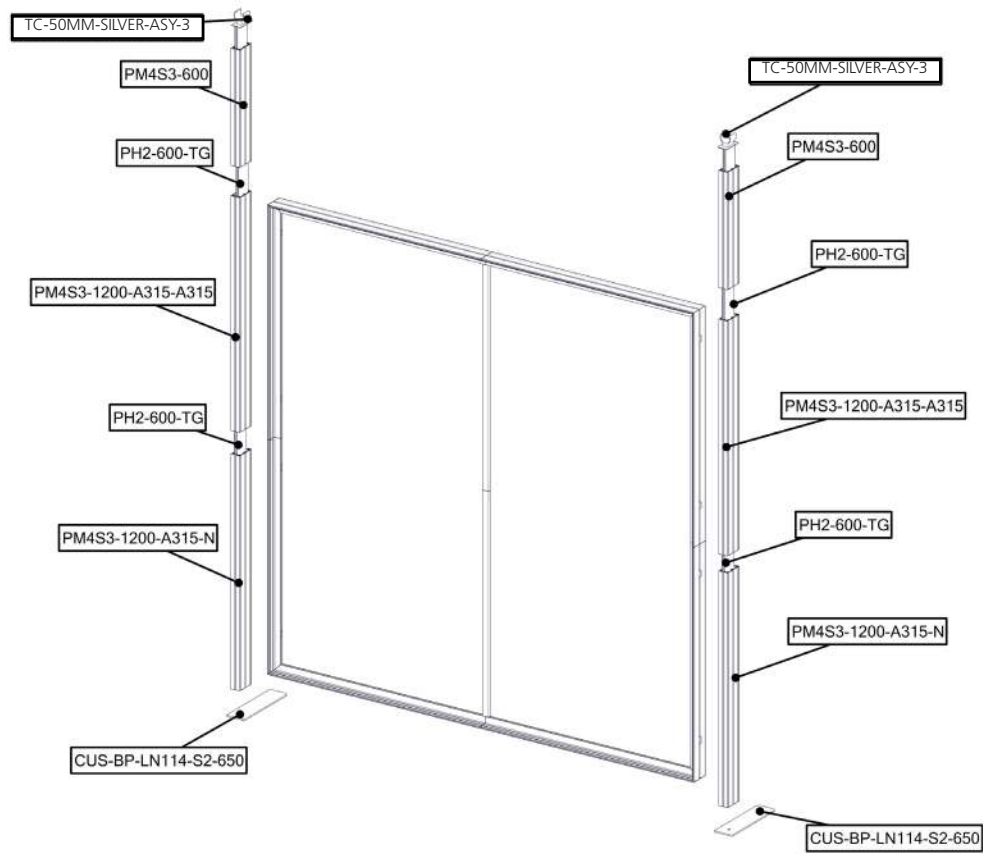

**-ASSEMBLE SIDE SUPPORTS, CUSTOM STABILIZING BASE  
& FABRIC STRUCTURE CLAMPS**

# Exploded Diagram

HP-K-29

-SUGGESTED LAYOUT SECTION 1.2

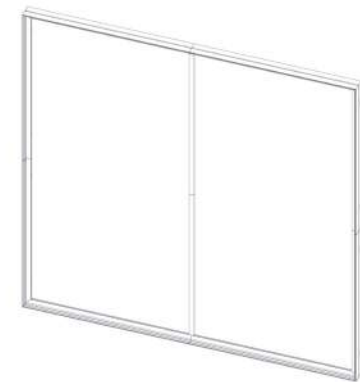
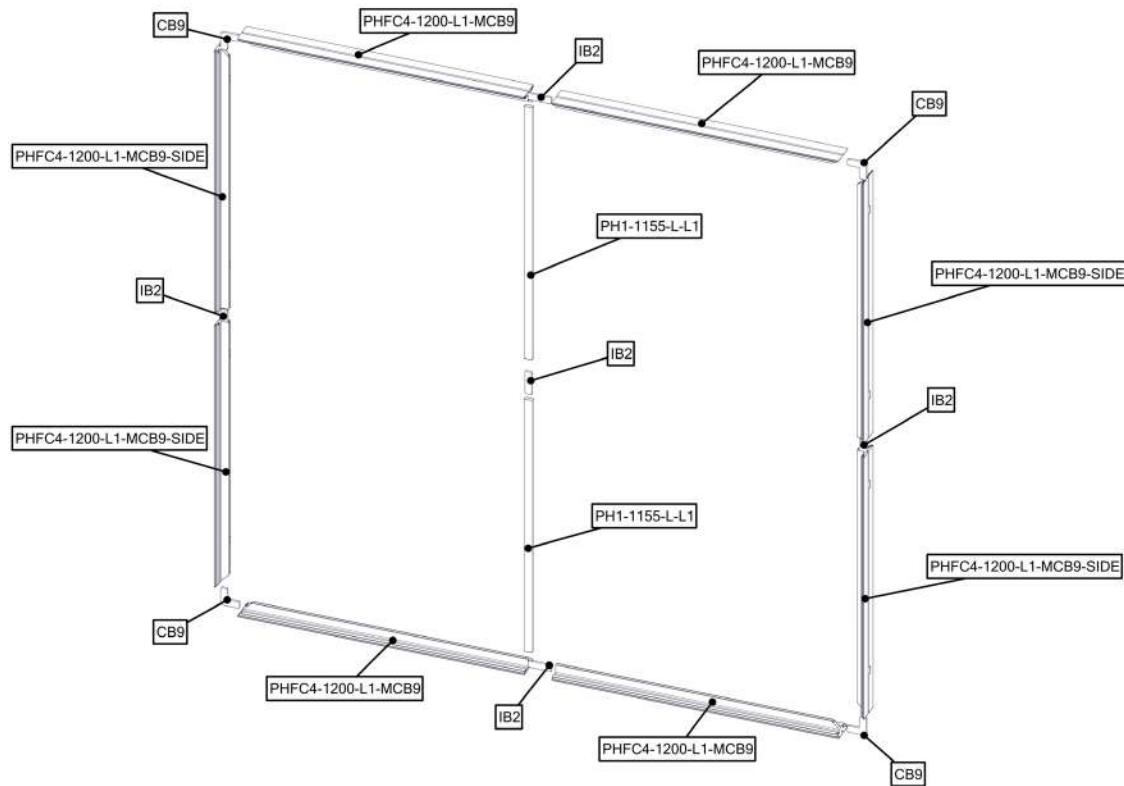

**-ASSEMBLE 2ND VECTOR FRAME WITH PH1 SUPPORTS**

# Exploded Diagram

HP-K-29

-SUGGESTED LAYOUT SECTION 1.2

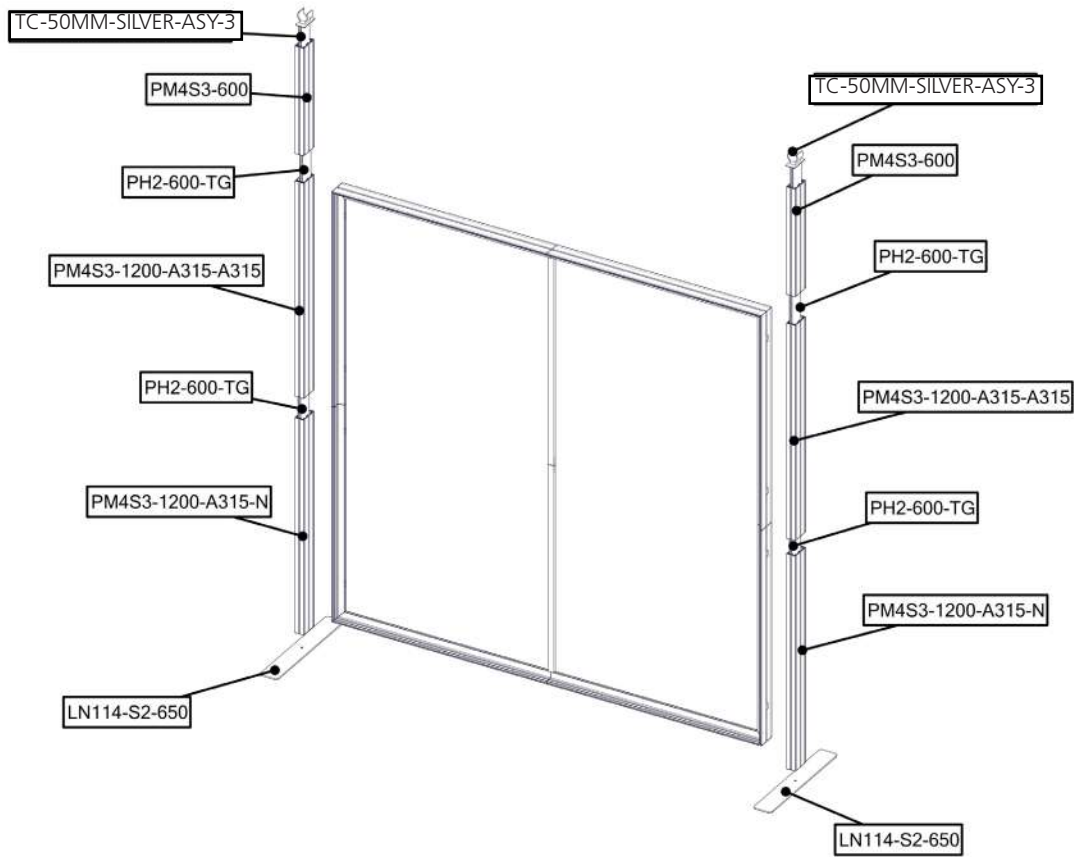

**-ASSEMBLE 2ND VECTOR FRAME SIDE SUPPORTS,  
CUSTOM STABILIZING BASE  
& FABRIC STRUCTURE CLAMPS**

# Exploded Diagram

HP-K-29

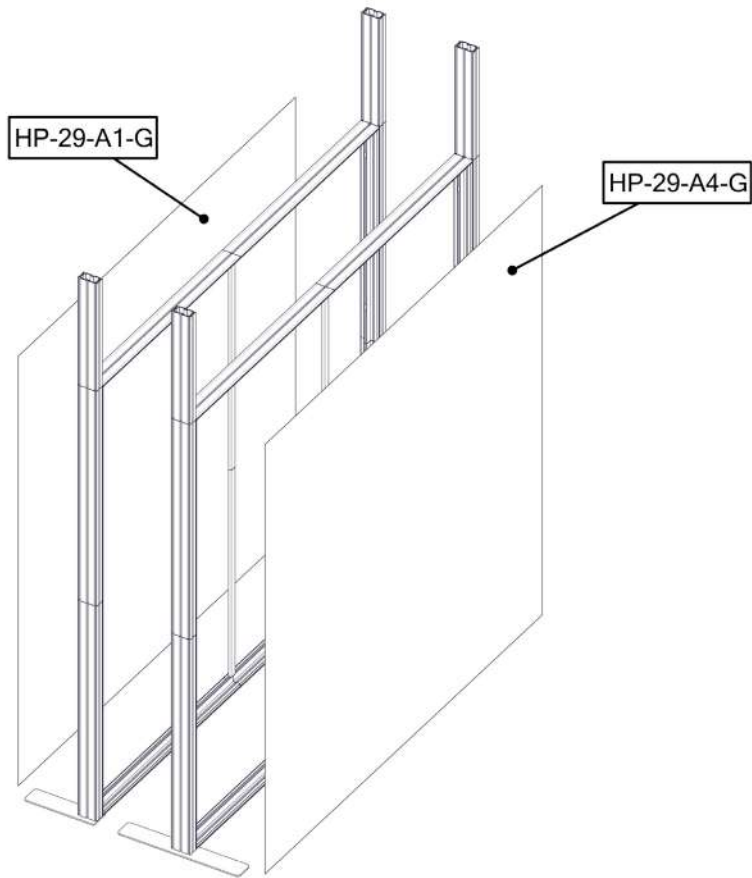

**-ATTACH GRAPHICS TO FRONT OF BOTH FRAMES**

# Exploded Diagram

HP-K-29

-SUGGESTED LAYOUT SECTION 1.3

**STEP 1**

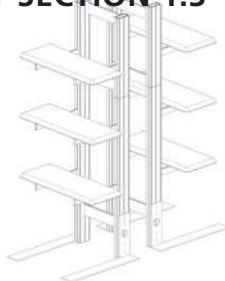

**-ASSEMBLE PM4S3-MK-SHELF-UNIT  
FRAME BEFORE ATTEMPTING THIS STEP**

**STEP 2**

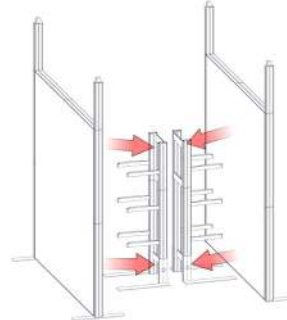

**-PLACE FRAMES IN DESIRED LOCATIONS  
BY PULLING FRAMES TOWARDS UNITS**

**STEP 3**

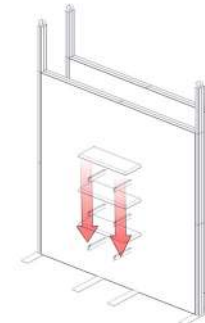

**-ONCE FRAMES & PMS3-MK-SHELVING  
UNITS ARE IN PLACE ATTACH SHELVING.**

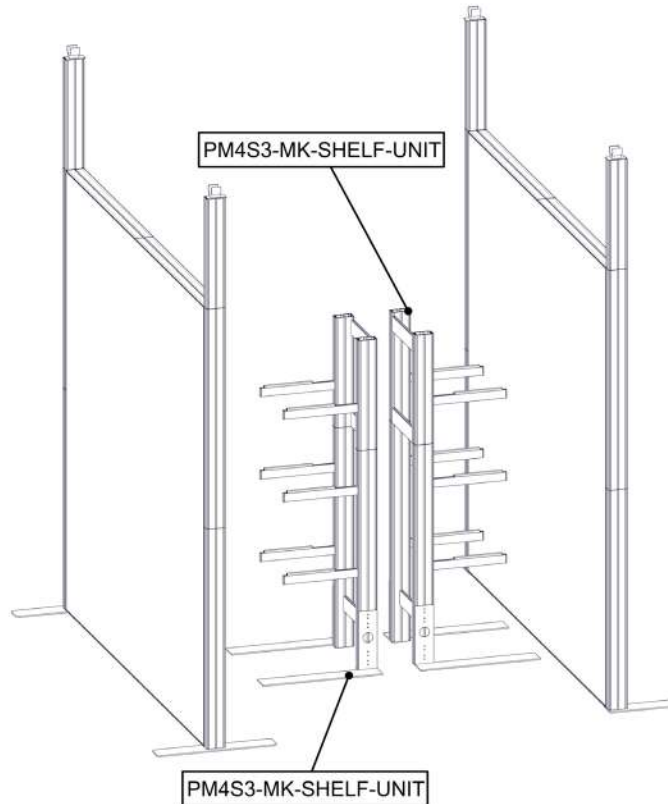

**-ASSEMBLE & PLACEMENT OF PM4S3-MK-SHELF-UNITS**

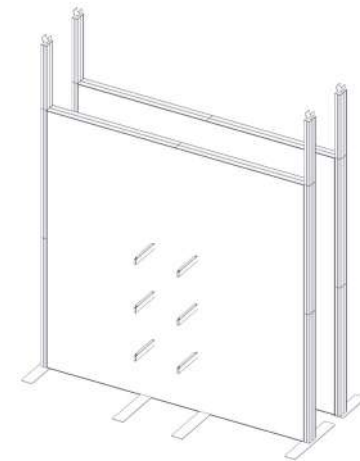
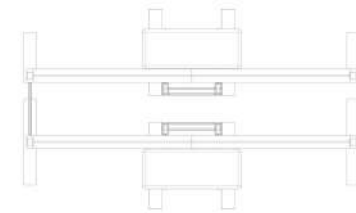



# Exploded Diagram

HP-K-29

-SUGGESTED LAYOUT SECTION 1.4

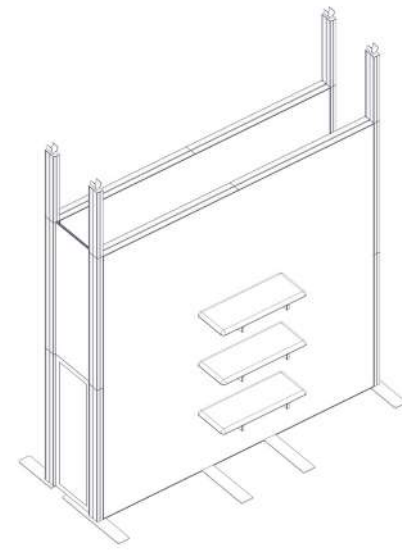
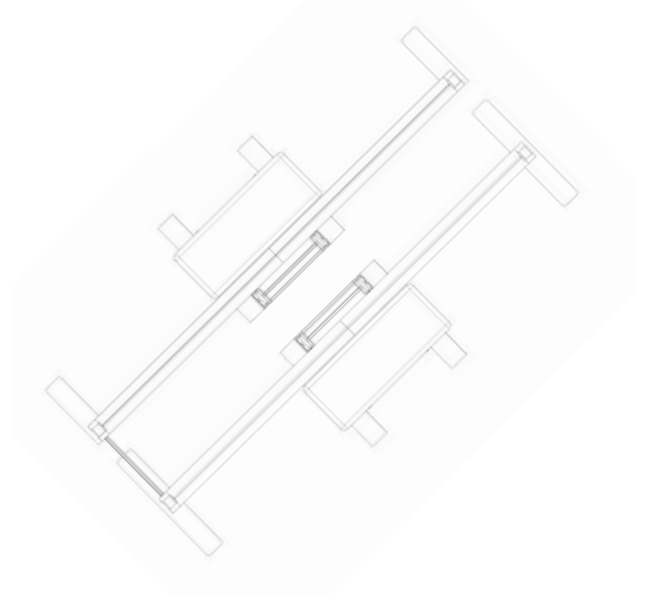
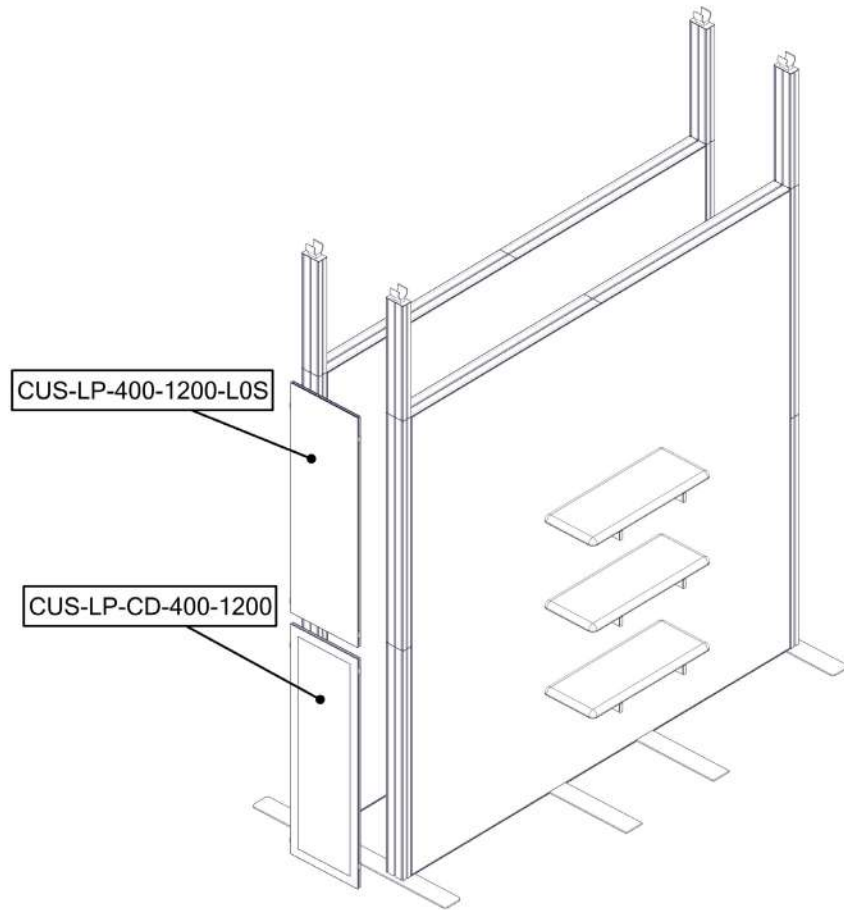

**-ATTACH SIDE PANEL & PANEL DOOR**

# Exploded Diagram

HP-K-29

-SUGGESTED LAYOUT SECTION 1.5

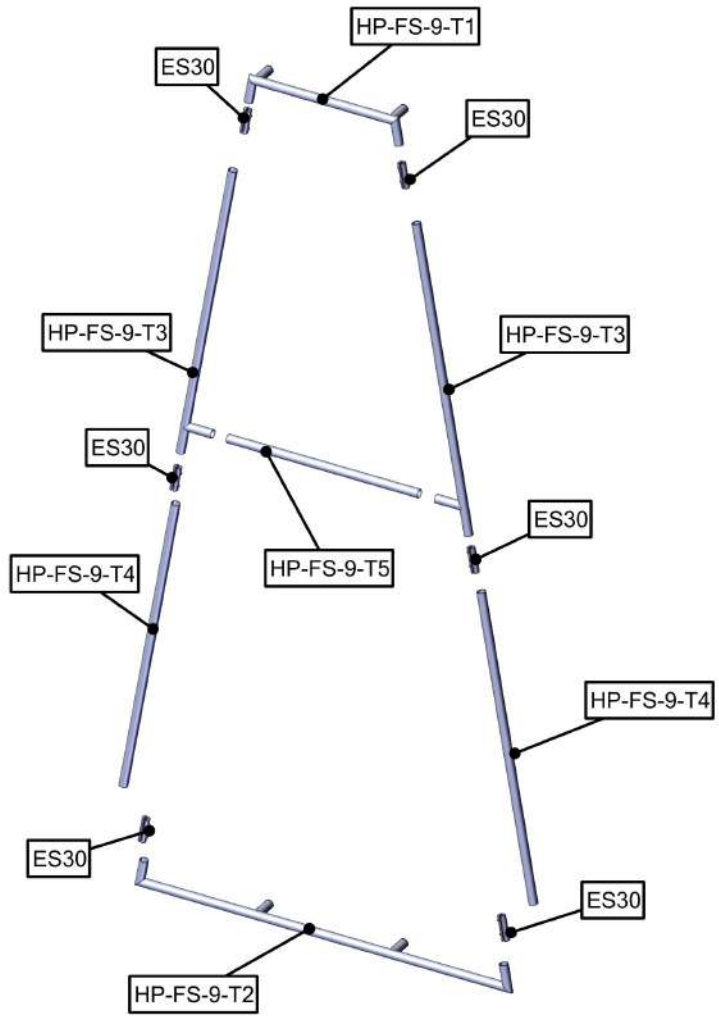

**-ASSEMBLE HP-FS-9**

**HP-29-A5-G**

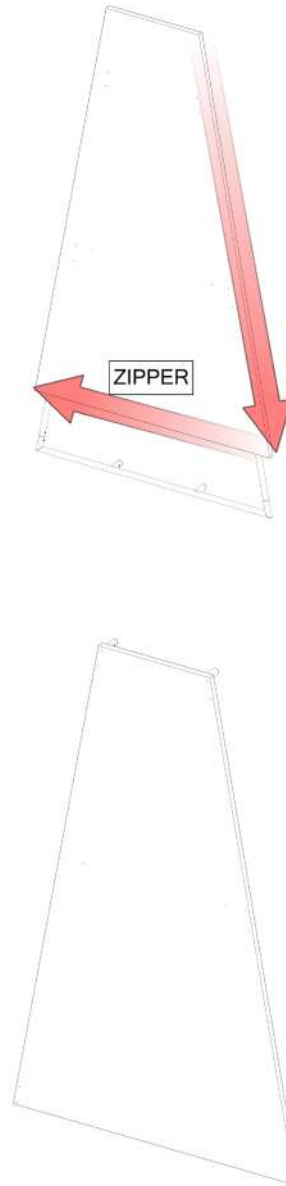

# Labeling Connection Diagram

HP-K-29

-ASSEMBLE HP-FS-9

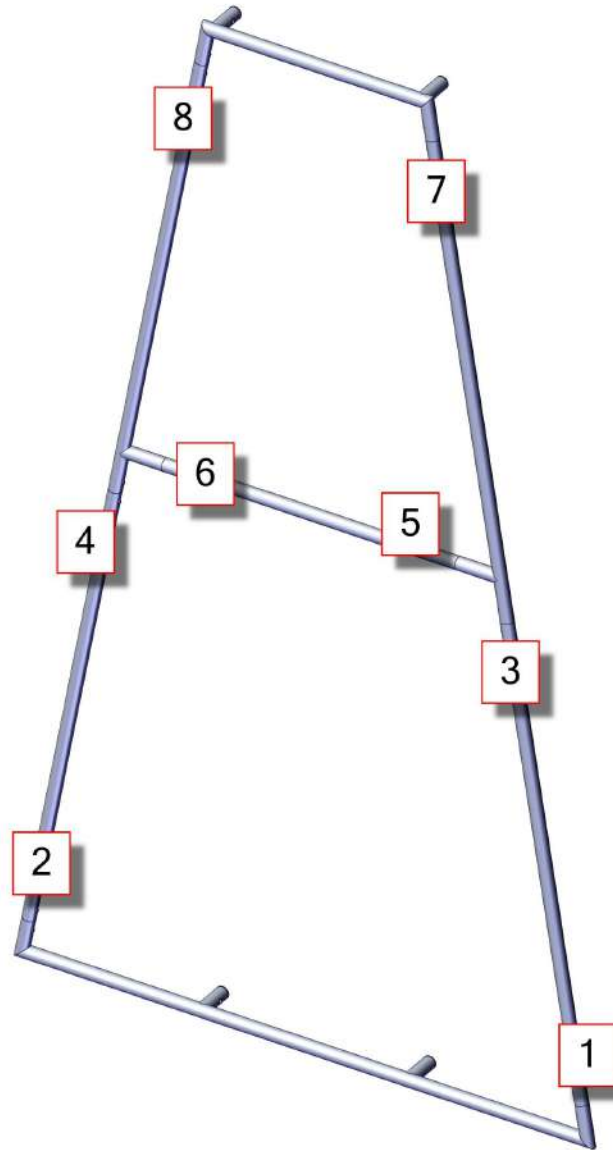

# Labeling Connection Diagram

HP-K-29

-SUGGESTED LAYOUTSECTION 1.5

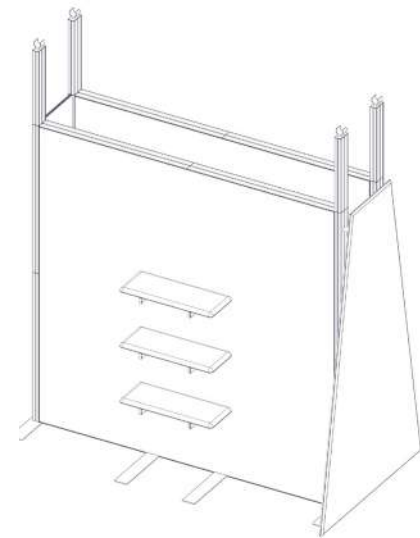
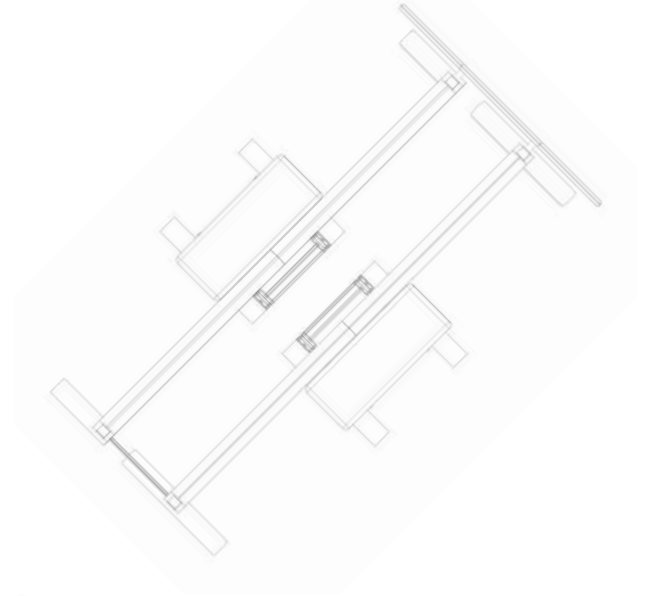
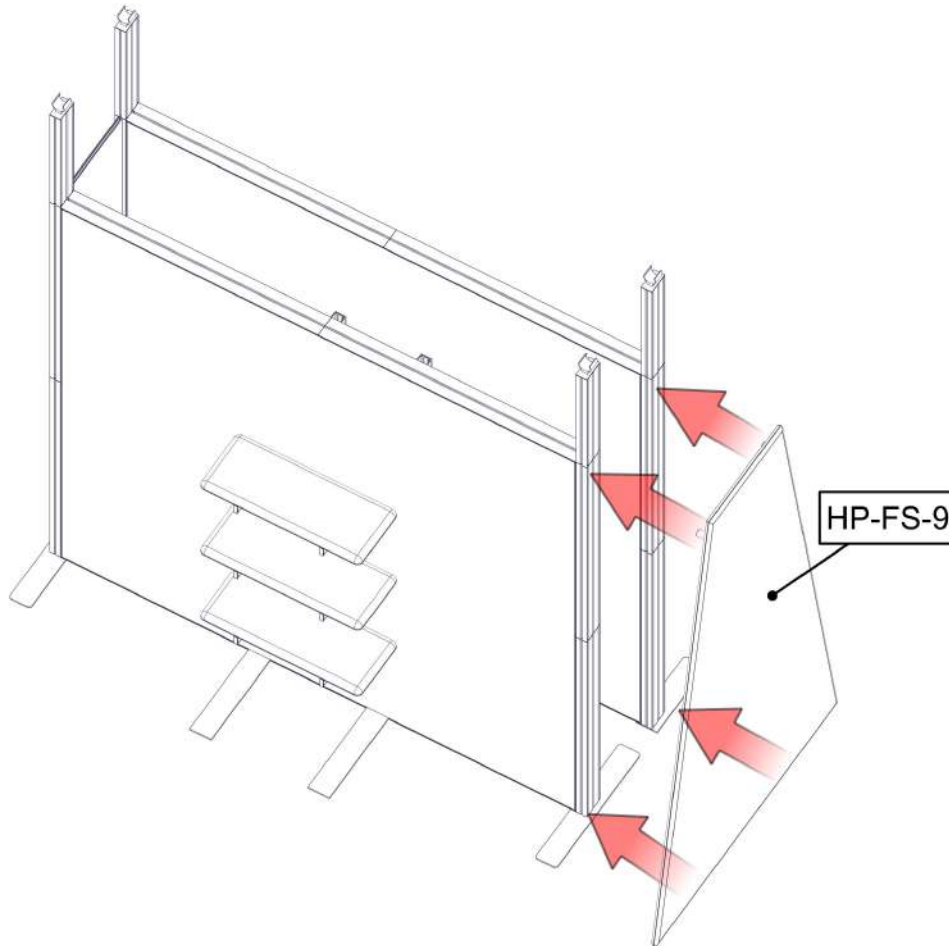

**-ATTACH HP-FS-9 TO BOTH VECTOR FRAMES**

# Labeling Connection Diagram

HP-K-29

-SUGGESTED LAYOUT SECTION 1.6

-HP-FS-10

-HP-FS-11

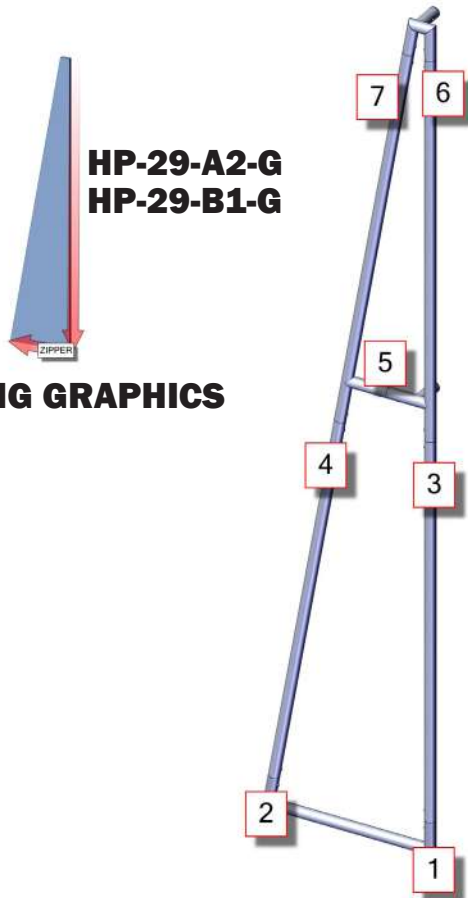

-HP-FS-10

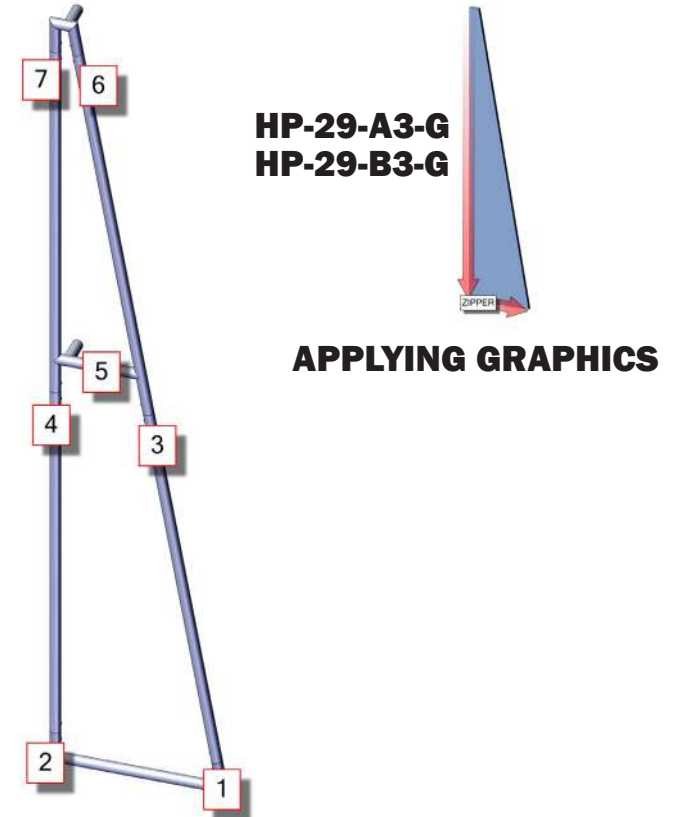
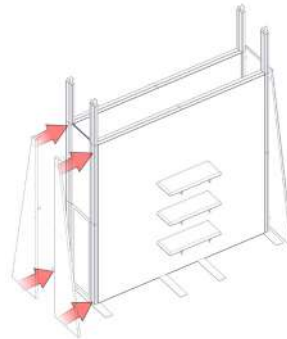

-HP-FS-11

# Labeling Connection Diagram

HP-K-29

-SUGGESTED LAYOUT SECTION 1.6

-ASSEMBLE HP-FS-10 & HP-FS-11 FRAMES

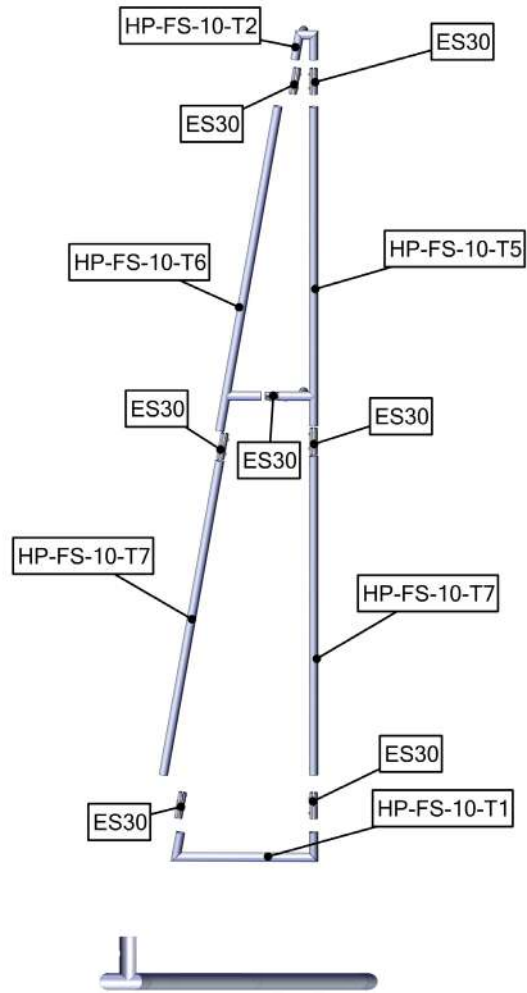

**HP-FS-10**

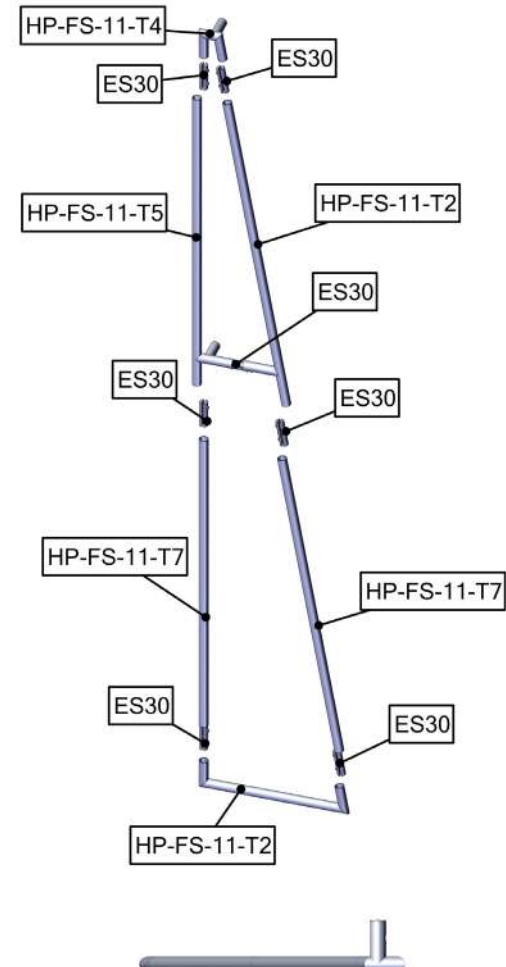

**HP-FS-11**

# Labeling Connection Diagram

HP-K-29

-SUGGESTED LAYOUT SECTION 1.6

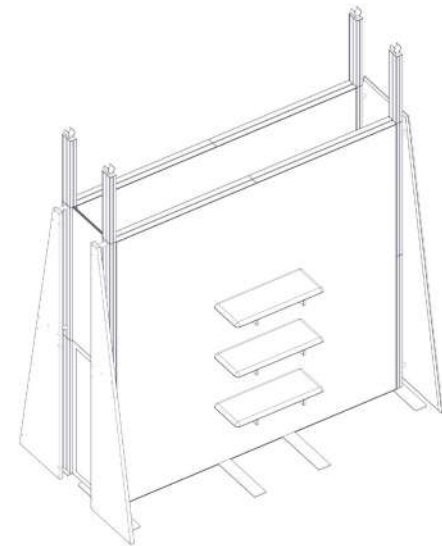
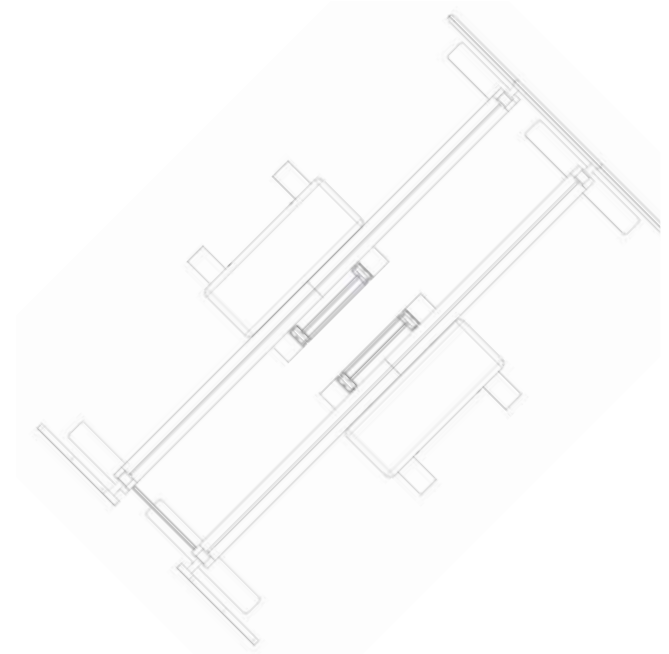
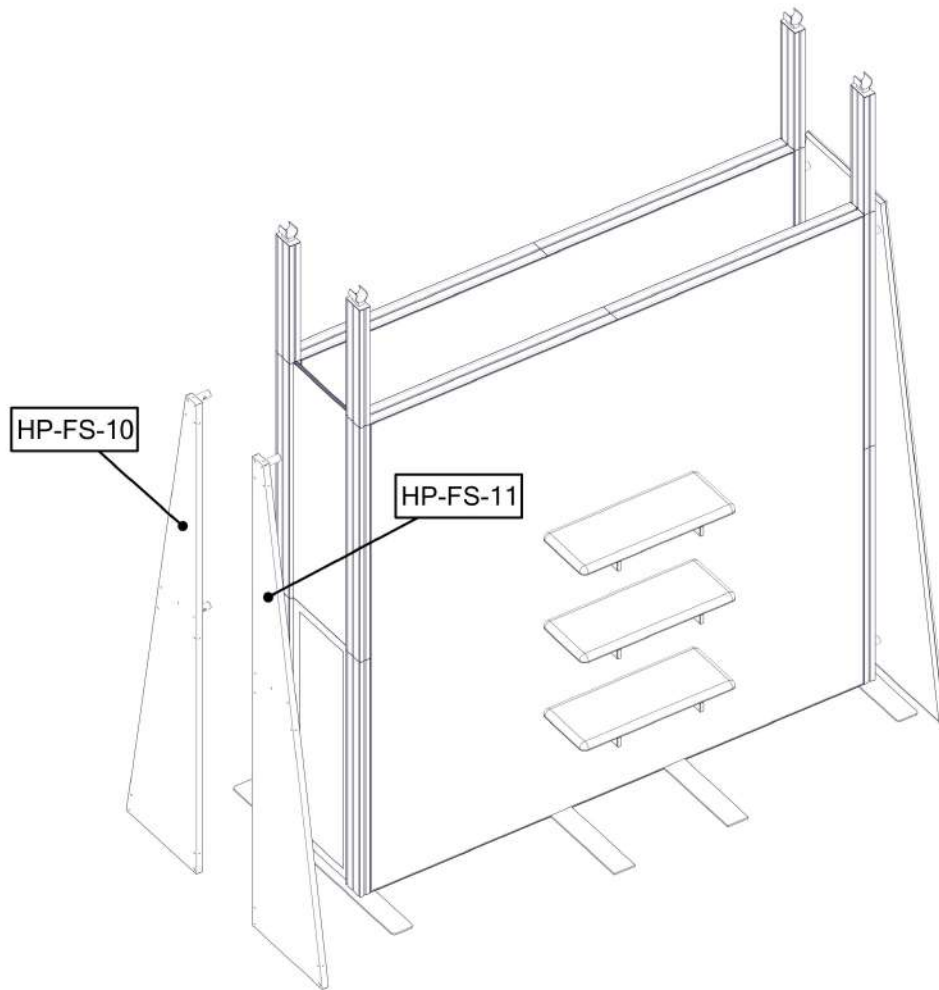

**-ATTACH HP-FS-10 & HP-FS-11 TO BOTH VECTOER FRAMES**

# Labeling Connection Diagram

HP-K-29

-SUGGESTED LAYOUT SECTION 1.8

-HP-FS-PILL

**STEP 1**

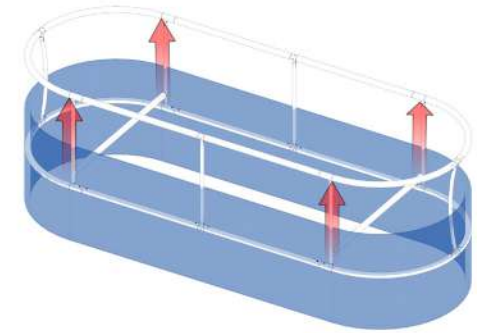

**APPLYING GRAPHICS**

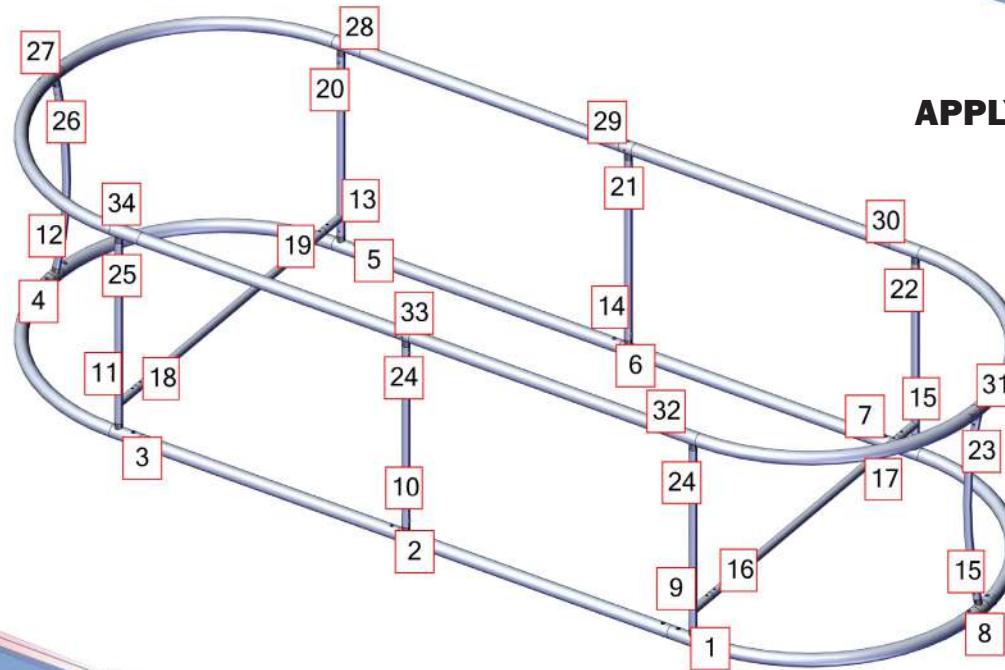

**STEP 2**

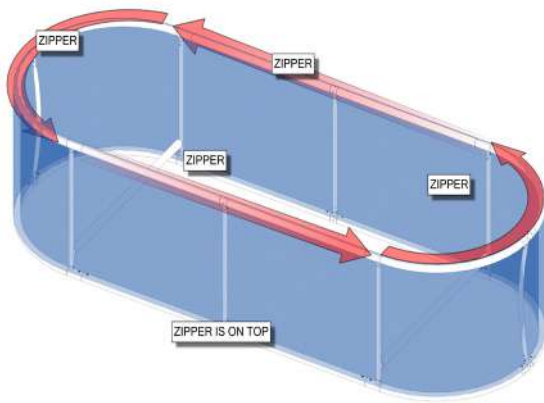

**APPLYING GRAPHICS**

**HP-29-D-G**



# Labeling Diagram

HP-K-29

-SUGGESTED SECTION 1.8

**-HP-FS-PILL**

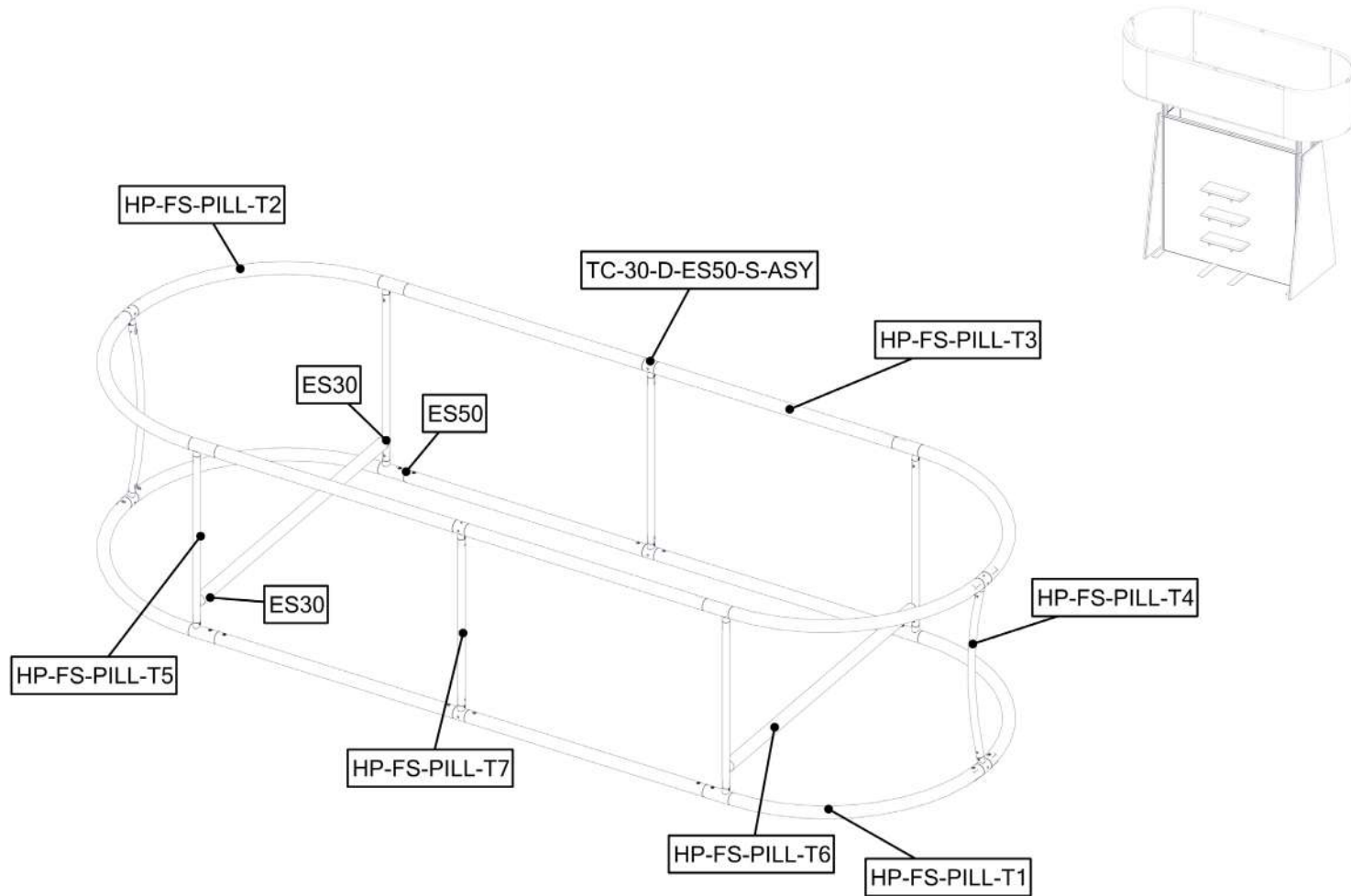

**-FOLLOWING PAGE IS AN ATTACHED PDF  
WITH DETAILED ASSEMBLY INSTRUCTIONS**

# Labeling Diagram

HP-K-29

-SUGGESTED SECTION 1.8

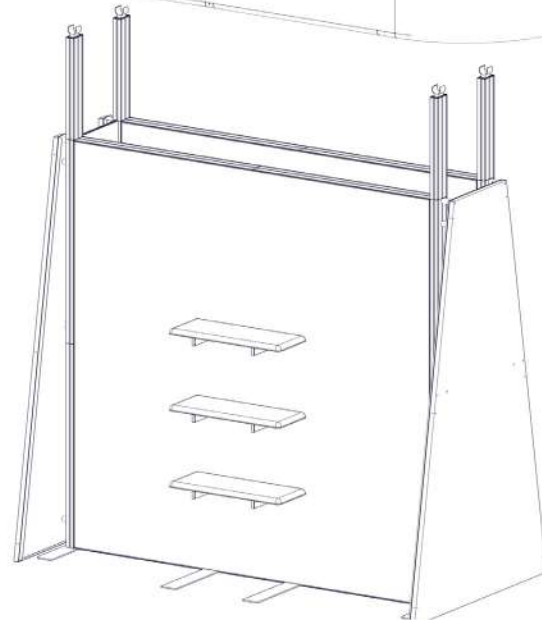
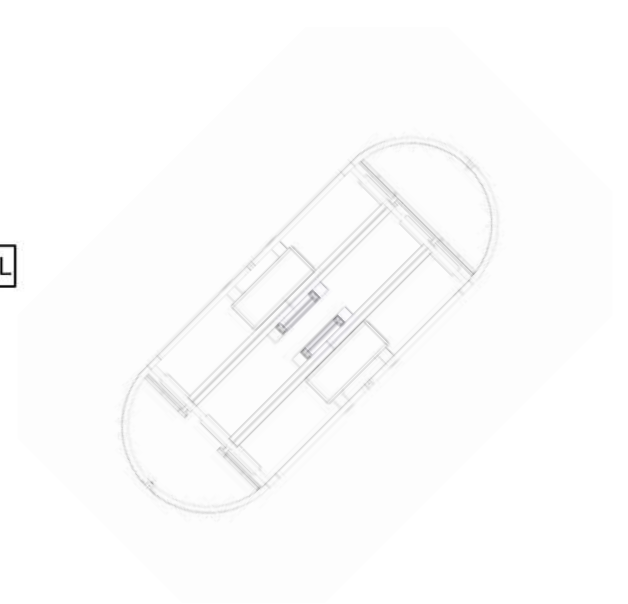
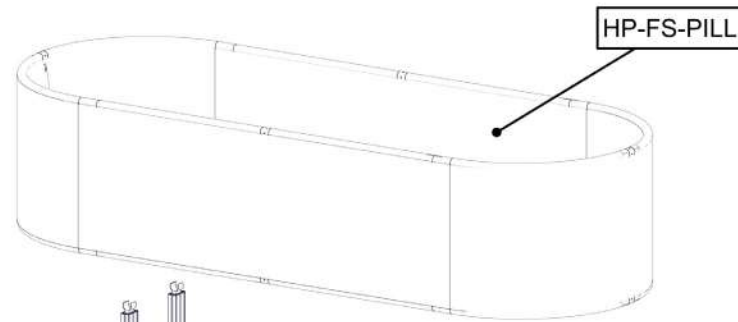
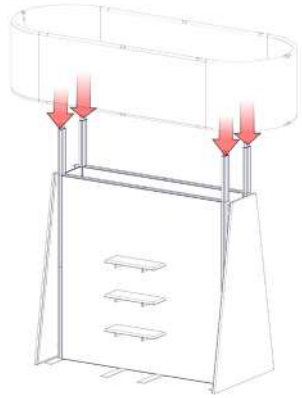

**-ATTACH HP-FS-PILL TO TOP OF FRAMES**

# Labeling Diagram

HP-K-29

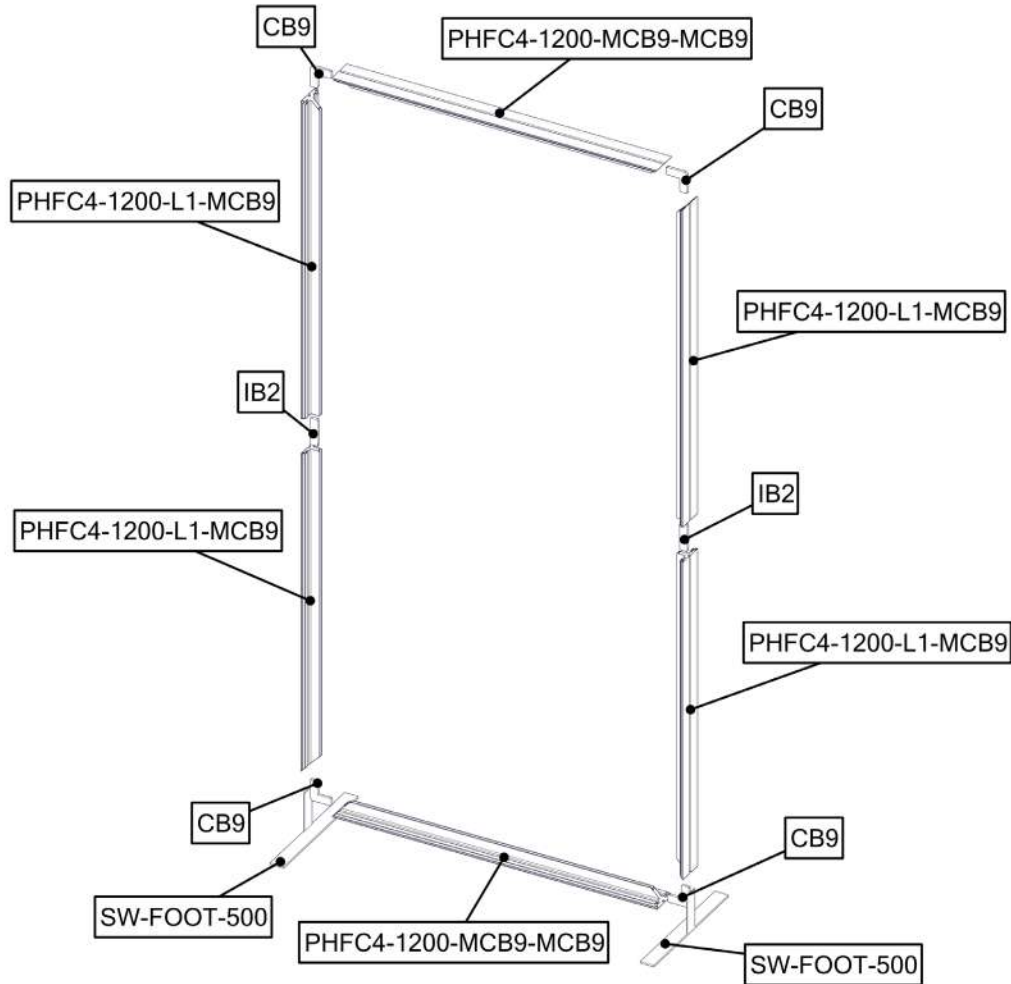

**-ASSEMBLE 2 OUTER VECTOR FRAMES**

**OUTER VECTOR FRAME 1**

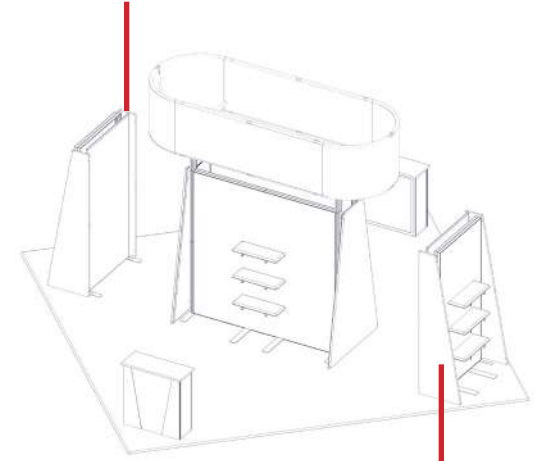

**OUTER VECTOR FRAME 2**



# Labeling Diagram

HP-K-29

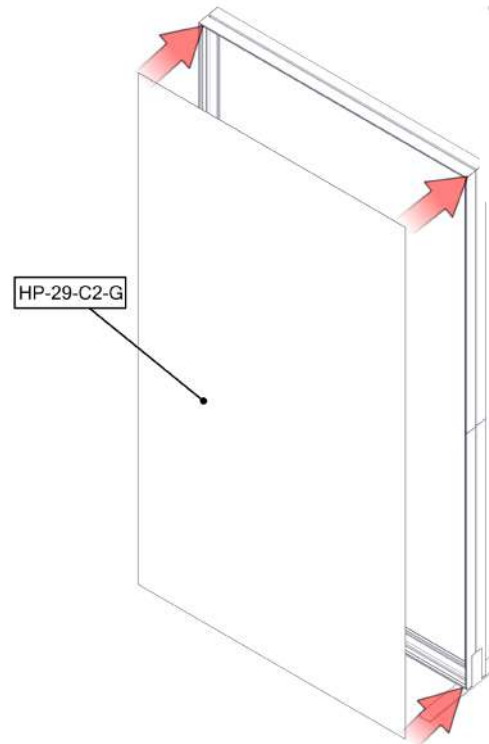
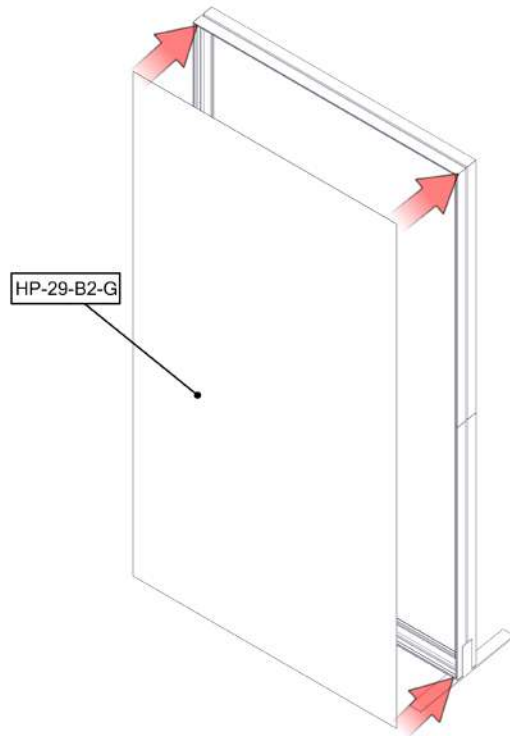

**OUTER VECTOR FRAME 1**

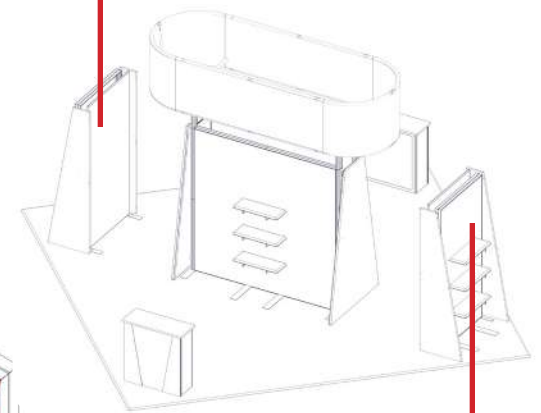

**OUTER VECTOR FRAME 2**

**-ATTACH GRAPHICS TO THE OUTER VECTOR FRAMES**

# Labeling Diagram

HP-K-29

-SUGGESTED SECTION 1.11

## STEP 1

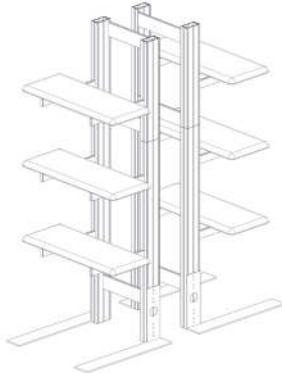

**-ASSEMBLE PM4S3-MK-SHELF-UNIT  
FRAME BEFORE ATTEMPTING THIS STEP**

## STEP 2

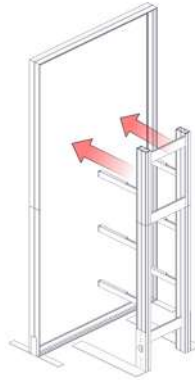

**-PLACE FRAMES IN DESIRED LOCATIONS  
BY PULLING FRAMES TOWARDS UNITS**

## STEP 3

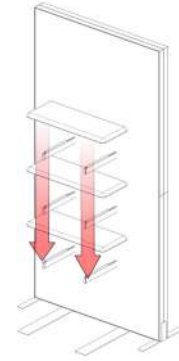

**-ONCE FRAMES & PMS3-MK-SHELF-  
UNITS ARE IN PLACE ATTACH SHELVING.**

## OUTER VECTOR FRAME 1

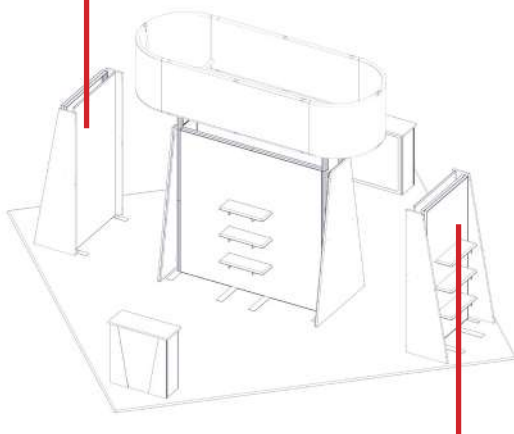

## OUTER VECTOR FRAME 2

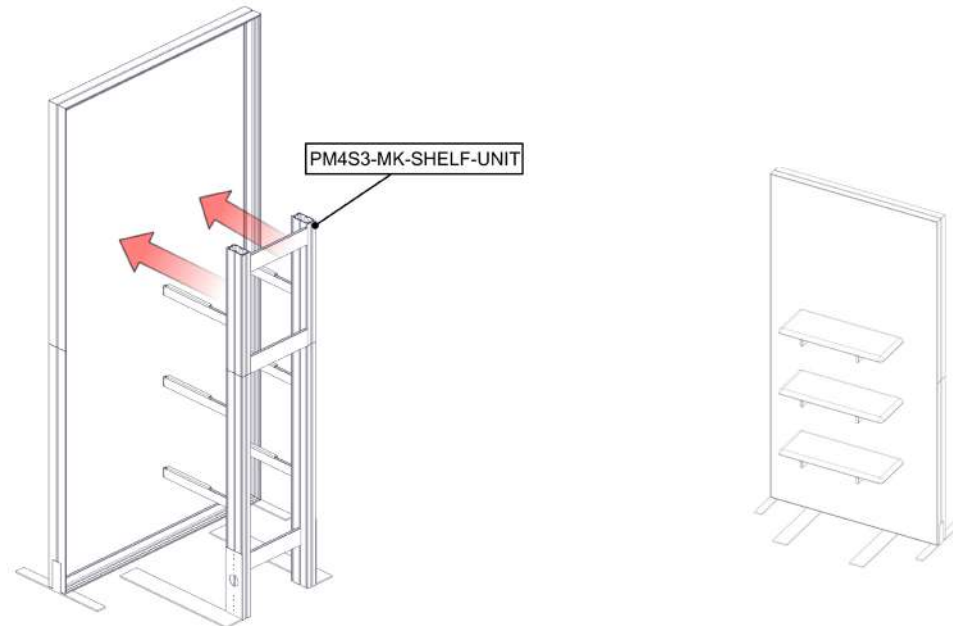

**-ASSEMBLE & PLACEMENT OF PM4S3-MK-SHELF-UNIT**

# Labeling Diagram

HP-K-29

-SUGGESTED SECTION 1.9

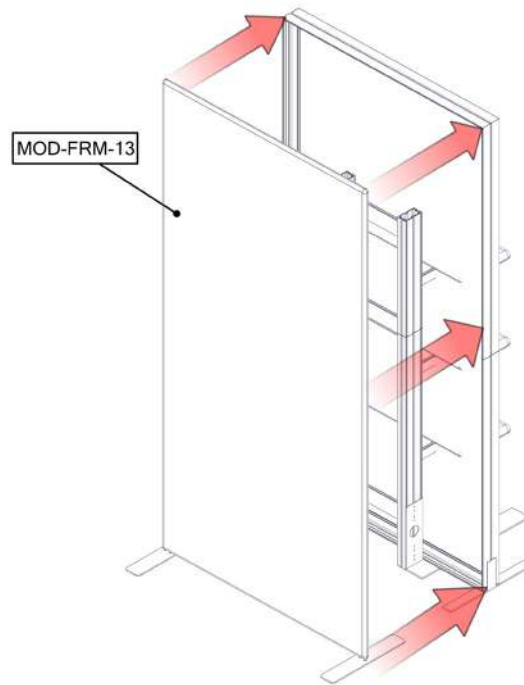

**-PLACEMENT OF 2 MOD-FRM-13**

**OUTER VECTOR FRAME 1**

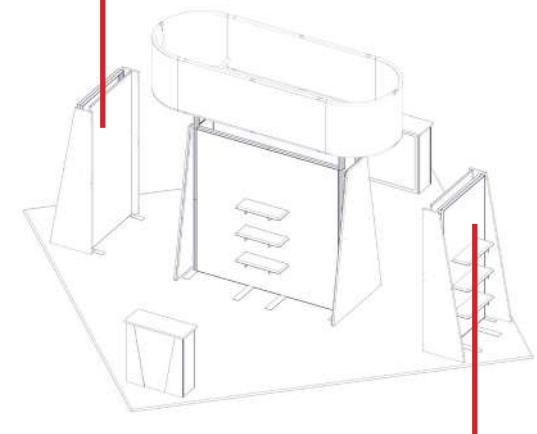

**OUTER VECTOR FRAME 2**

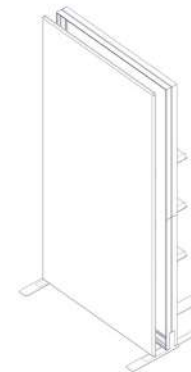
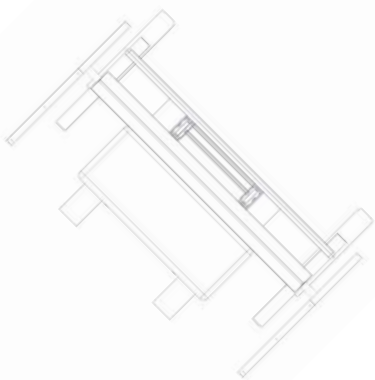

**FOLLOWING THIS PAGE IS A DETAILED PDF WITH ASSEMBLY INSTRUCTIONS**

# Exploded Diagram

HP-K-29

-SUGGESTED SECTION 1.7

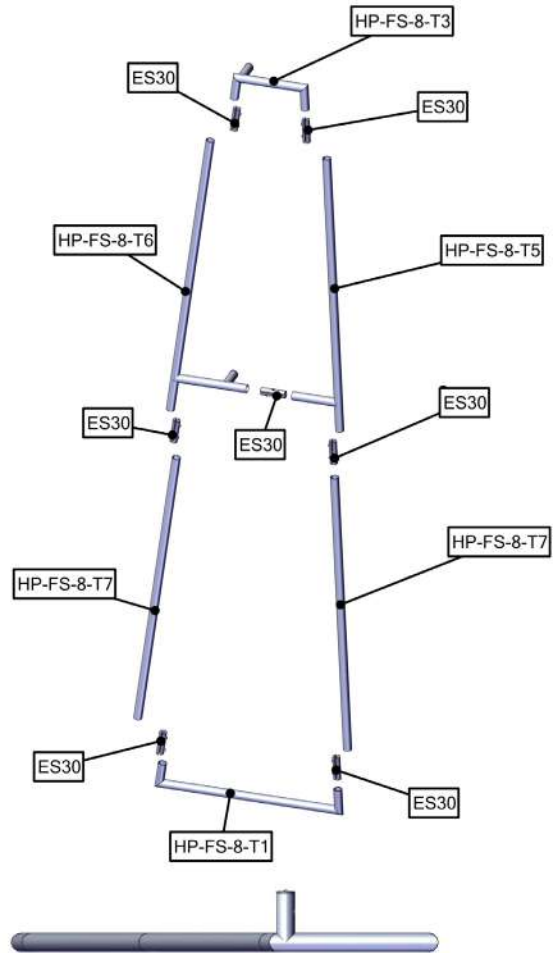

**-ASSEMBLE HP-FS-8 FABRIC STRUCTURE**



**HP-FS-8**



**HP-29-C1-G**

**-ATTACH GRAPHIC**

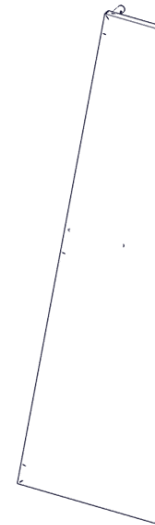

# Exploded Diagram

HP-K-28

-SUGGESTED SECTION 1.10

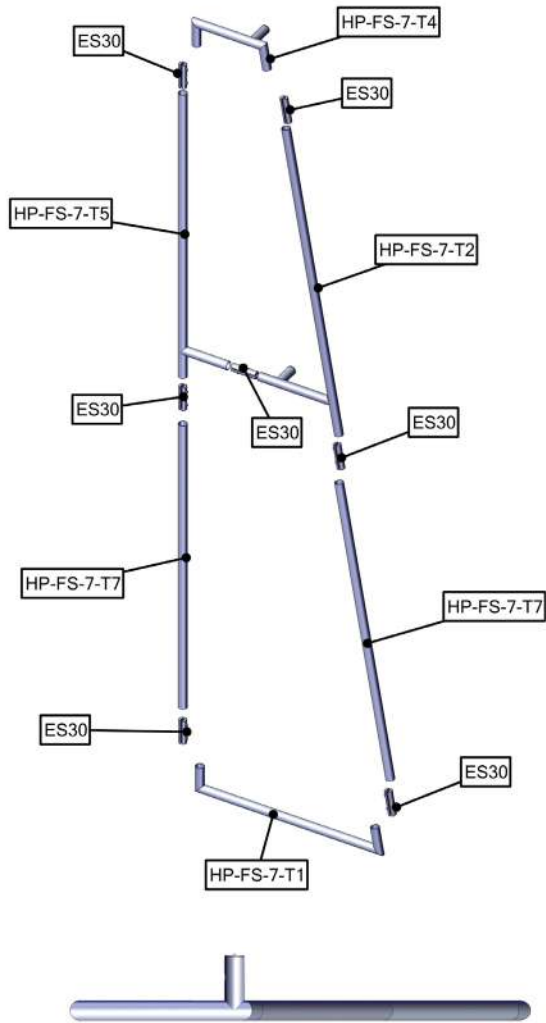

HP-29-C3-G

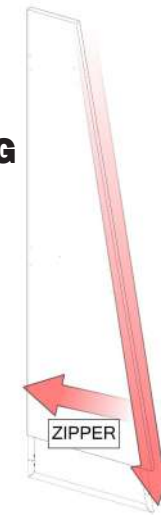

-ATTACH GRAPHIC

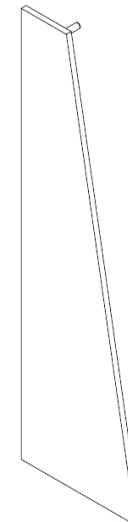

-ASSEMBLE HP-FS-7 FABRIC STRUCTURE



# Labeling Diagram

HP-K-29

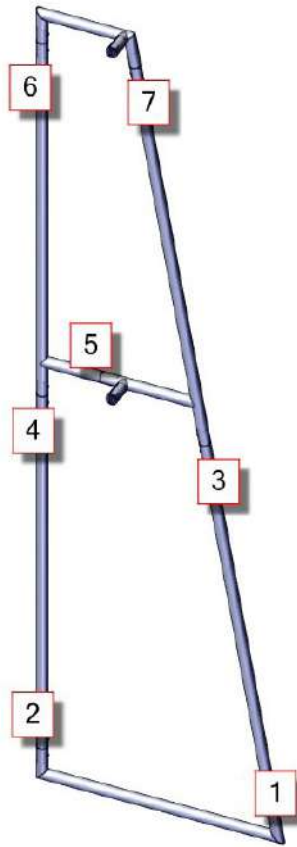

- HP-FS-8

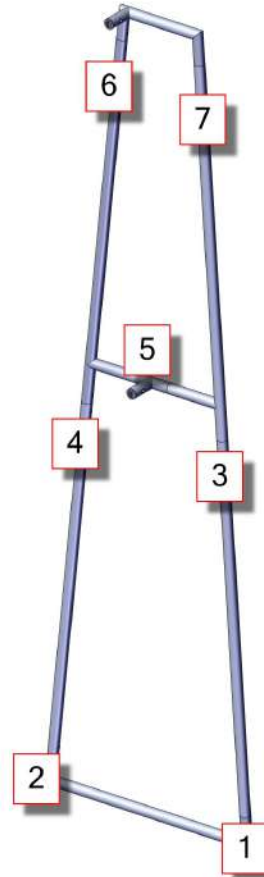

- HP-FS-7

# Exploded Diagram

HP-K-29

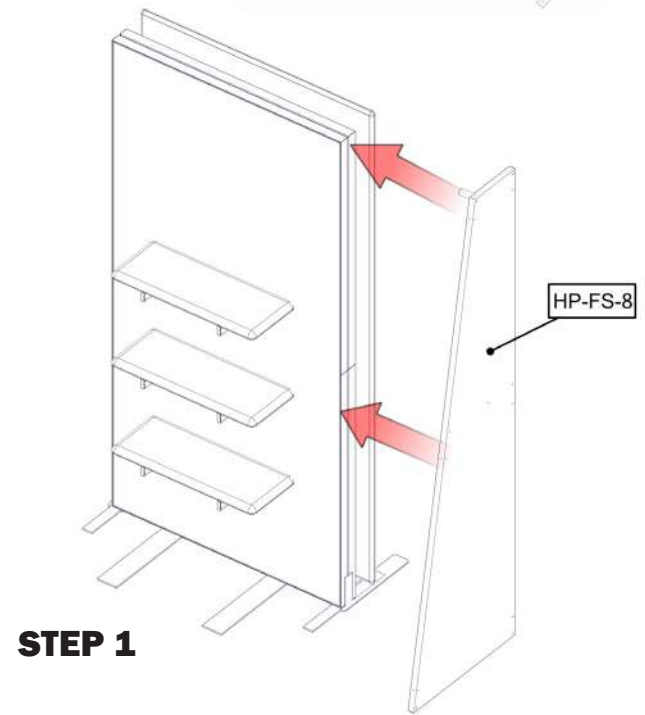
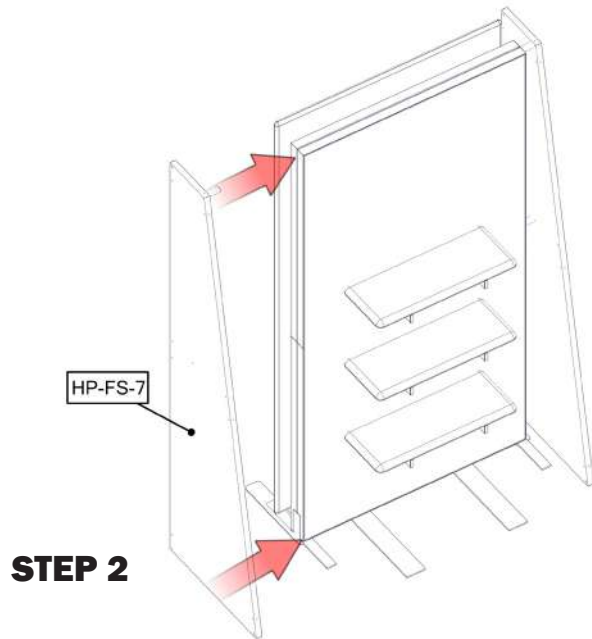
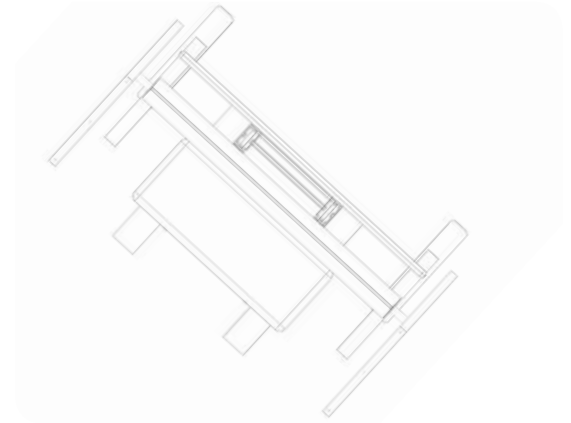
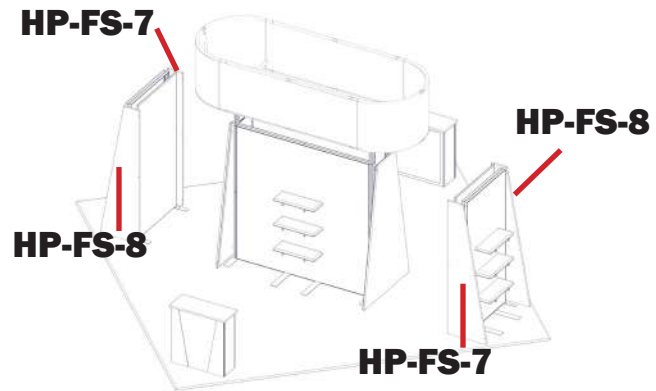

**-ATTACH FABRIC STRUCTURES TO OUTER VECTORS FRAMES**

# Suggested Kit Layout

HP-K-29

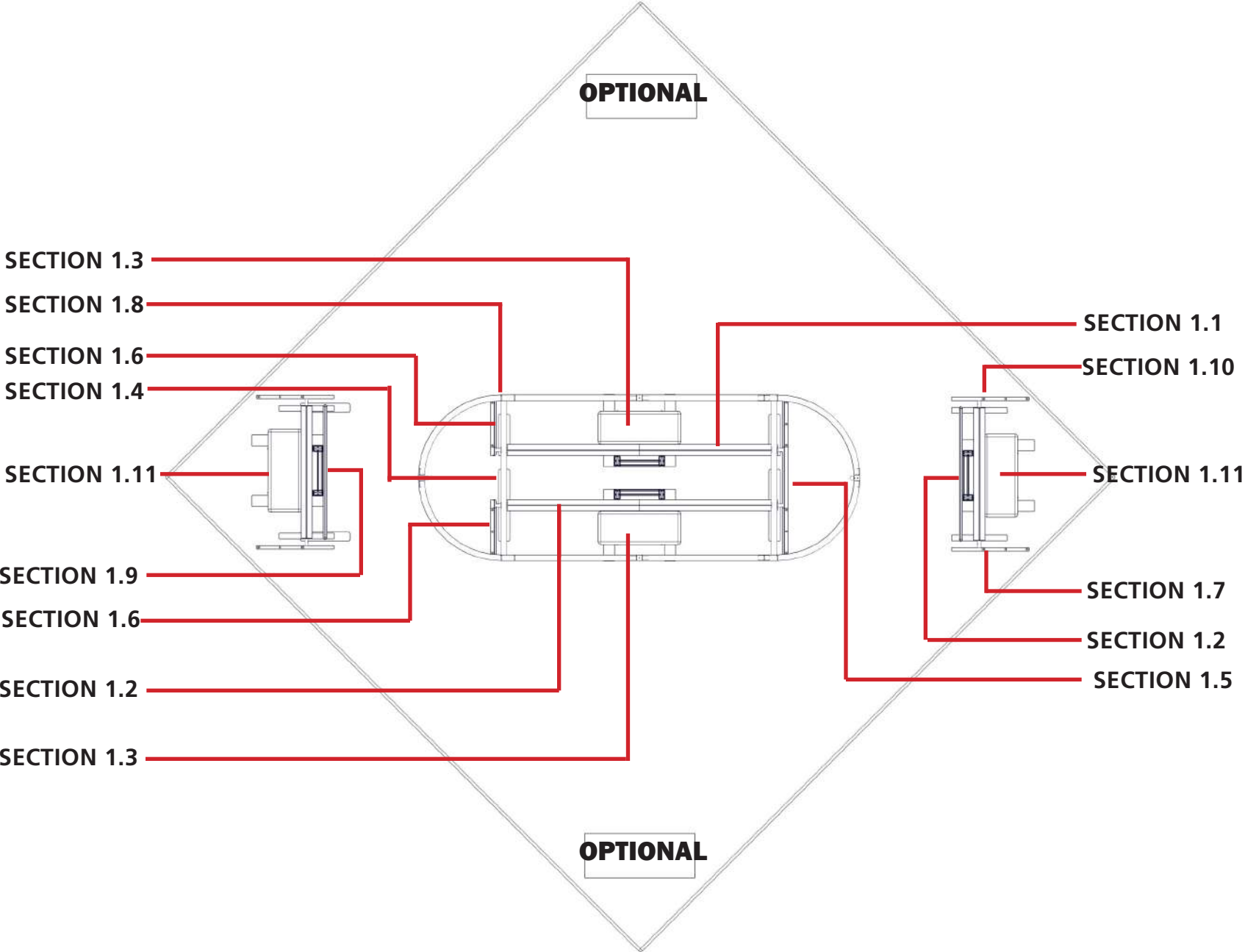

# Kit Assembly

## Step by Step

### Step 1.

Gather the components to build the vector frame. Use the Exploded View and the Labeling Diagram for part labels.

Reference Connection Method(s) 1, 2 and 3 for more details.

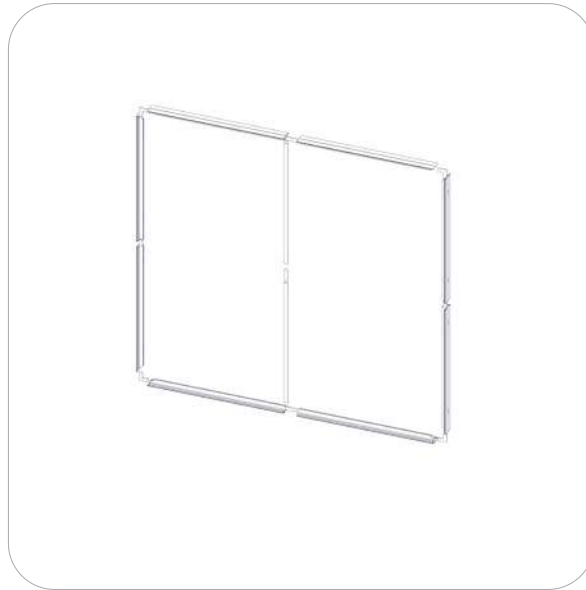
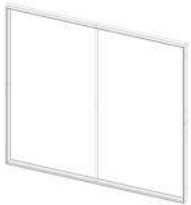

### Step 2.

Gather the components to build the vector frame side supports. Use the Exploded View and the Labeling Diagram for part labels.

Reference Connection Method(s) 1, 2 and 3 for more details.



### Step 3.

Gather the components to build the vector frame. Use the Exploded View and the Labeling Diagram for part labels.

Reference Connection Method(s) 1, 2 and 3 for more details.

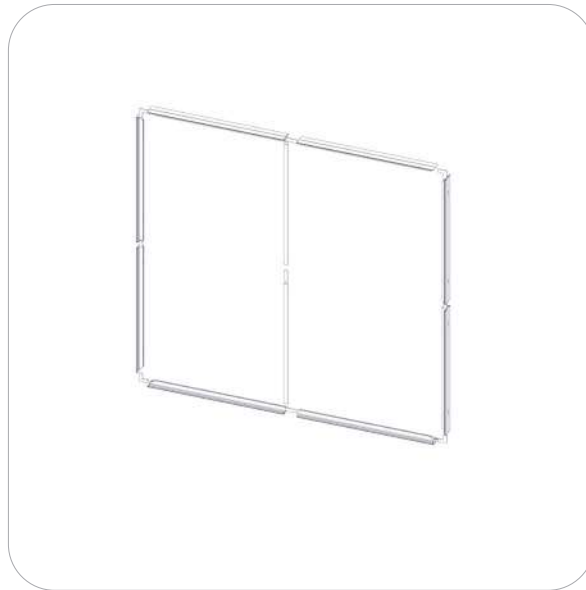
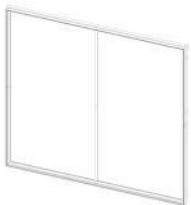

### Step 4.

Gather the components to build the vector frame side supports. Use the Exploded View and the Labeling Diagram for part labels.

Reference Connection Method(s) 1, 2 and 3 for more details.



# Kit Assembly

## Step by Step

### Step 1.

Gather graphics need to attach to front of both frames. Use the Exploded View and the Labeling Diagram for part labels.

Reference Connection Method(s) 8 for more details.

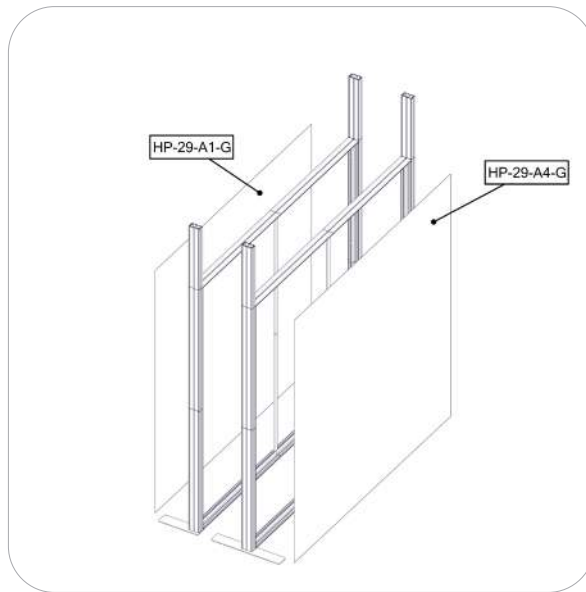

### Step 2.

Assemble PM4S3-MK-SHELF-UNIT.

Reference Connection Method(s) Attach detail PDF follows this page on assemble instructions

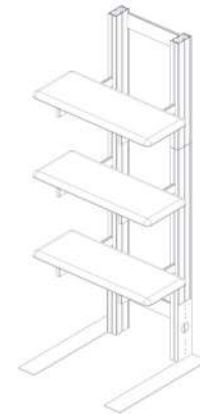

### Step 3.

Arrange PM4S3 UNIT in desired position. Use the Exploded View and the Labeling Diagram for part labels.

Reference Connection Method(s) Placement see PDF attached for instruction.



### Step 4.

Re-attach Shelves to unit once in position for both PM4S3 shelf units. Use the Exploded View and the Labeling Diagram for part labels.

Reference Connection Method(s) Placement see PDF attached for instruction.

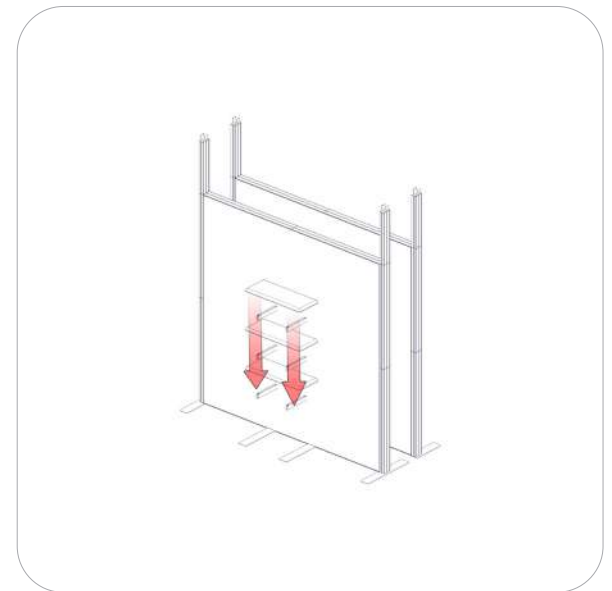
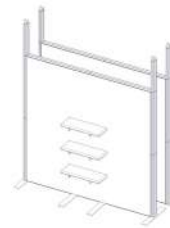

# Kit Assembly

## Step by Step

### Step 5.

Gather panel & panel door for installation. Use the Exploded View and the Labeling Diagram for part labels.

Reference Connection Method(s) 1, 2 and 3 for more details.

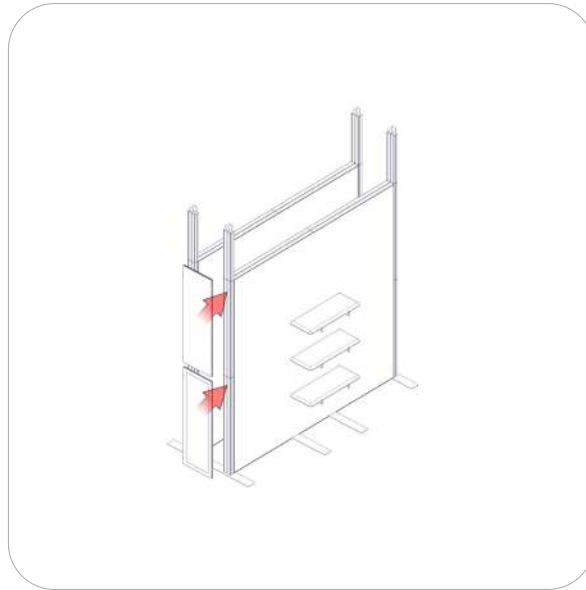

### Step 6.

Gather the components to build HP-FS-9. Use the Exploded View and the Labeling Diagram for part labels.

Reference Connection Method(s) 10 for more details.

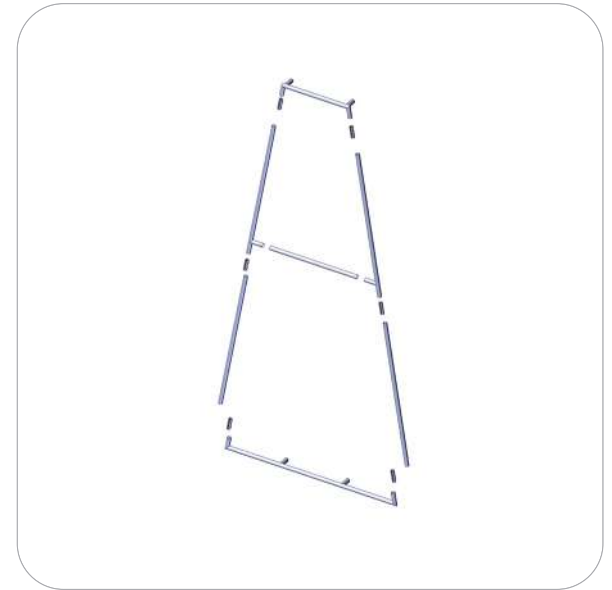

### Step 7.

Gather the components to build HP-FS-10. Use the Exploded View and the Labeling Diagram for part labels.

Reference Connection Method(s) 10 for more details.

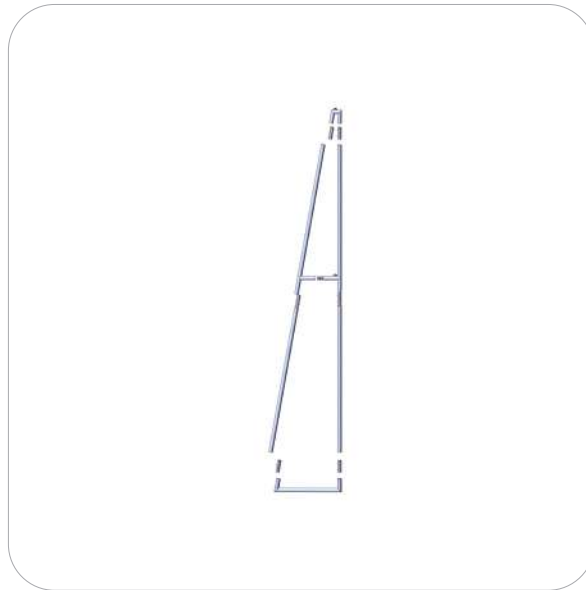

### Step 8.

Gather the components to build HP-FS-11. Use the Exploded View and the Labeling Diagram for part labels.

Reference Connection Method(s) 10 for more details.

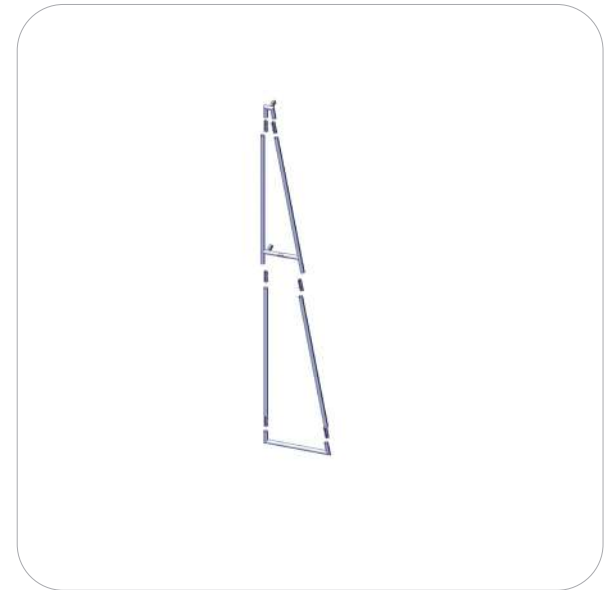

# Kit Assembly

## Step by Step

### Step 9.

Attach graphic to HP-FS-9. Use the Exploded View and the Labeling Diagram for part labels.

Reference Connection Method(s)



### Step 10.

Attach graphic to HP-FS-11. Use the Exploded View and the Labeling Diagram for part labels.

Reference Connection Method(s)

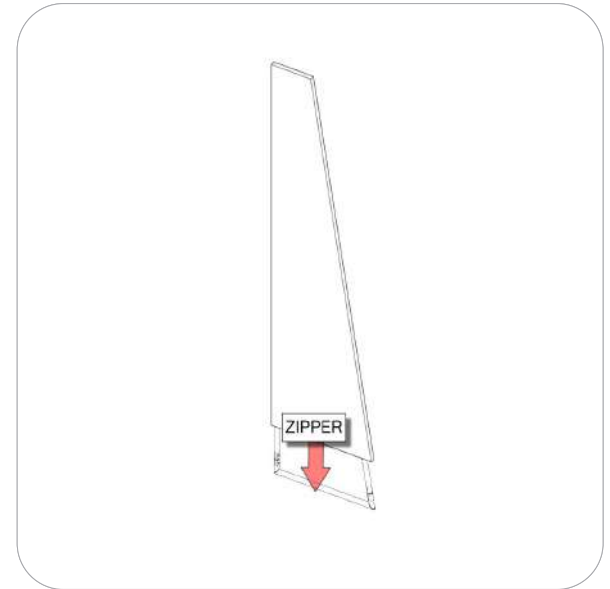
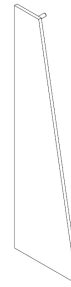

### Step 11.

Attach graphic to HP-FS-10. Use the Exploded View and the Labeling Diagram for part labels.

Reference Connection Method(s)

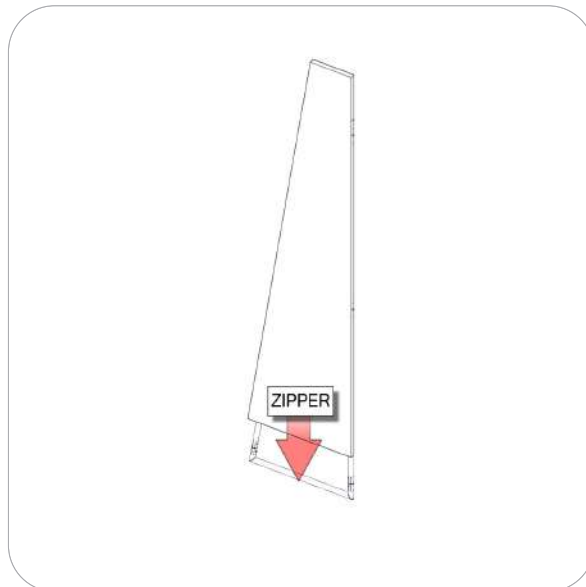

### Step 12.

Attach HP-FS-9 to frame. Use the Exploded View and the Labeling Diagram for part labels.

Reference Connection Method(s) 12 for more details.

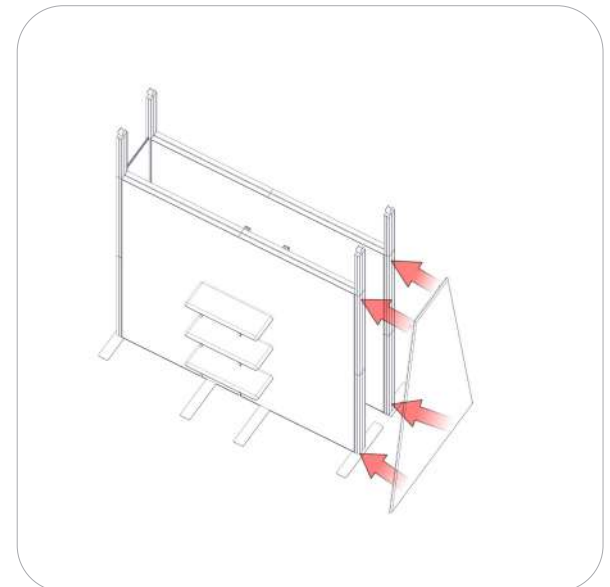

# Kit Assembly

## Step by Step

### Step 13.

Attach HP-FS-10 & HP-FS-11 to frame. Use the Exploded View and the Labeling Diagram for part labels.

Reference Connection Method(s) 12 for more details.

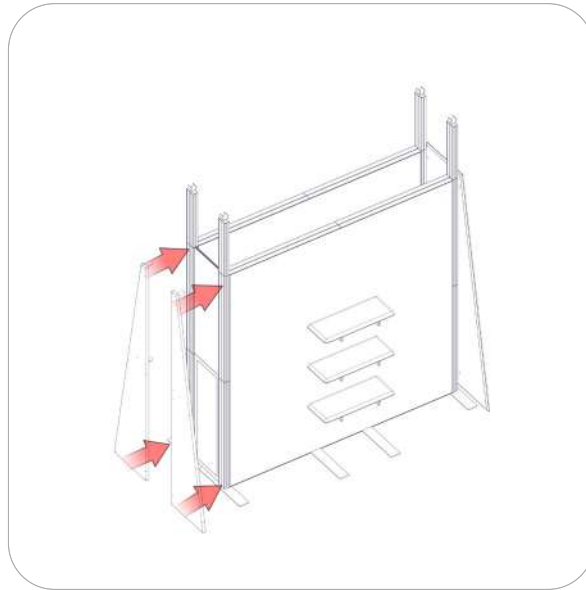

### Step 14.

Gather the components to build the BOTTOM. Use the Exploded View and the Labeling Diagram for part labels.  
Reference Connection Method(s) 9, 10, and 11 for more details.



### Step 15.

Gather the components to build the MIDDLE. Use the Exploded View and the Labeling Diagram for part labels.

Reference Connection Method(s) 9, 10, and 11 for more details.

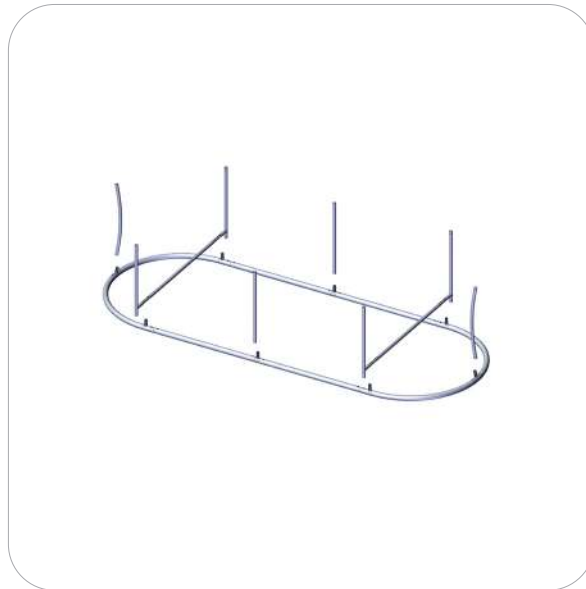

### Step 16.

Gather the components to build the TOP. Use the Exploded View and the Labeling Diagram for part labels.

Reference Connection Method(s) 9, 10, and 11

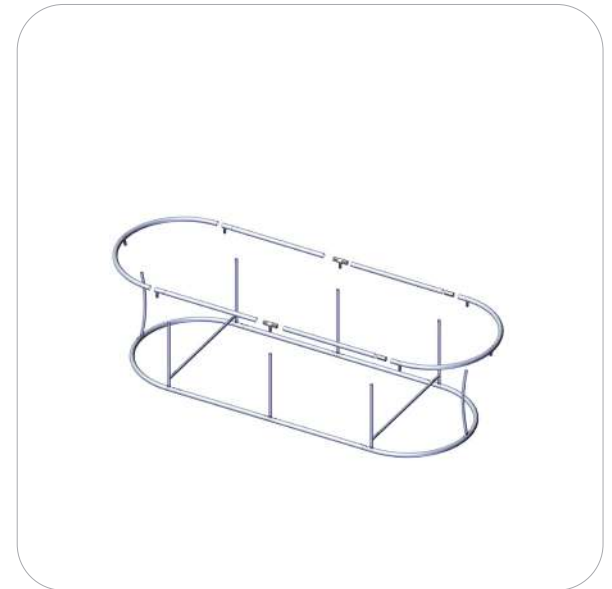



# Kit Assembly

## Step by Step

### Step 17.

Attach graphics

Reference Connection Method(s)  
3 for more details.

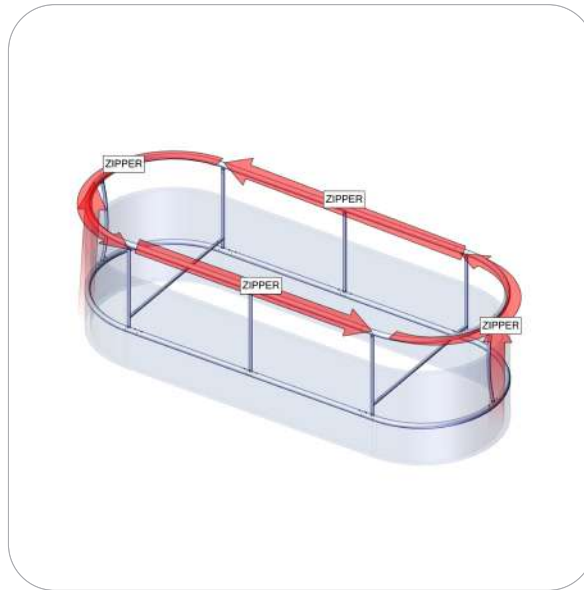
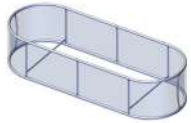

### Step 18.

Attach HP-FS-PILL to top of  
vector frames. Use the Exploded  
View and the Labeling Diagram  
for part labels.

Reference Connection Method(s)  
13 for more details.



### Step 19.

Assemble 2 outer vector frame.  
Use the Exploded View and the  
Labeling Diagram for part labels.

Reference Connection Method(s)  
1, 2 and 14 for more details.



### Step 20.

Attach graphics to both outer  
vector frame fronts. Use the  
Exploded View and the Labeling  
Diagram for part labels.

Reference Connection Method(s)  
8 for more details.

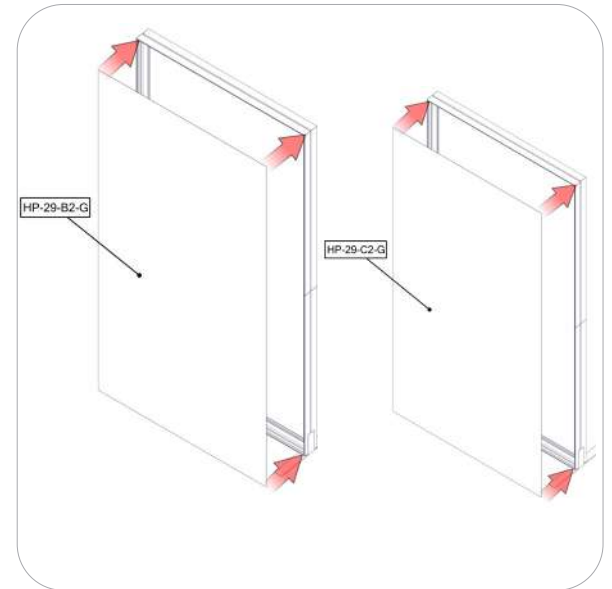

# Kit Assembly

## Step by Step

### Step 21.

Assemble MOD-FRM-13

Reference Connection Method(s)  
Attach detail PDF follows this page on assemble instructions

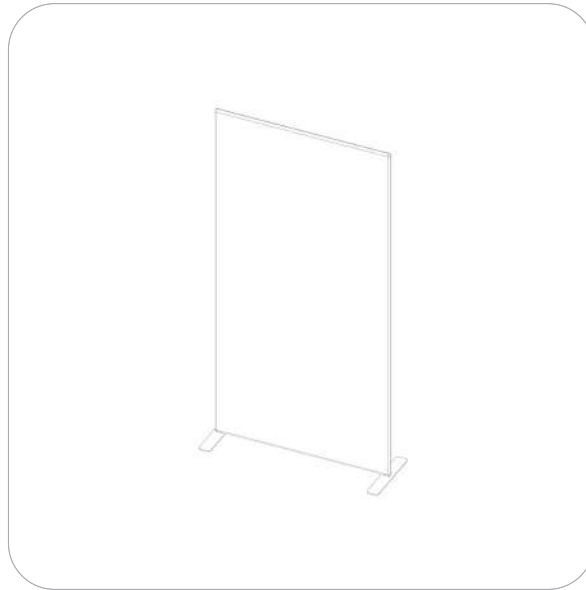

### Step 22.

Assemble PM4S3-MK-SHELF-UNIT.

Reference Connection Method(s)  
Attach detail PDF follows this page on assemble instructions

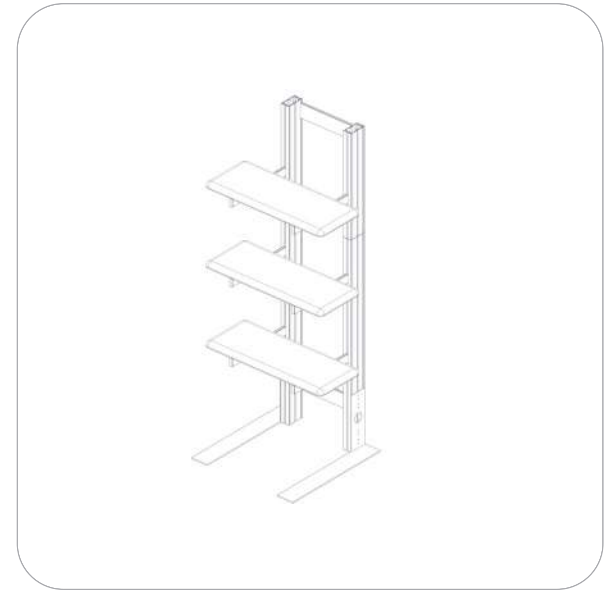

### Step 23.

Arrange PM4S3 UNIT in desired position. Use the Exploded View and the Labeling Diagram for part labels.

Reference Connection Method(s)  
Placement see PDF attached for instruction.



### Step 24.

Re-attach Shelves to unit once in position for both PM4S3 shelf units. Use the Exploded View and the Labeling Diagram for part labels.

Reference Connection Method(s)  
Placement see PDF attached for instruction.

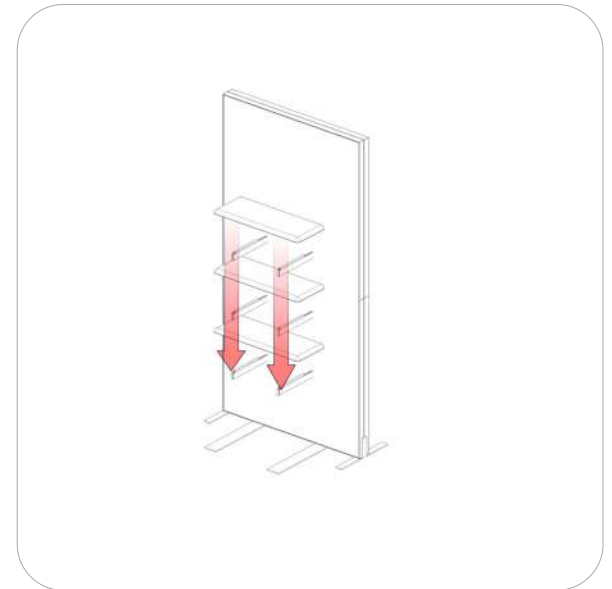

# Kit Assembly

## Step by Step

### Step 25.

Place MOD-FRM-13, VECTOR FRAME, and PM4S3-MK-SHELF-UNIT in desired position.

Reference Connection Method(s)  
Correct Placement

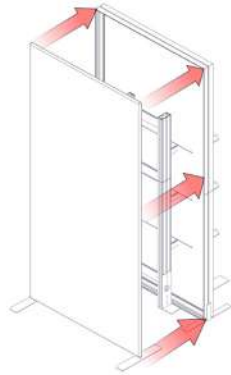

### Step 26.

Attach HP-FS-11 to frame. Use the Exploded View and the Labeling Diagram for part labels.

Reference Connection Method(s)  
12 for more details.

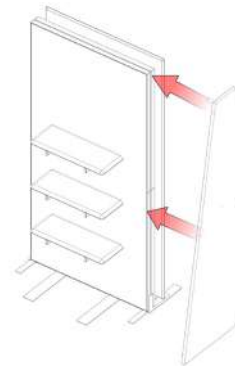

### Step 27.

Attach HP-FS-10 to frame. Use the Exploded View and the Labeling Diagram for part labels.

Reference Connection Method(s)  
12 for more details.

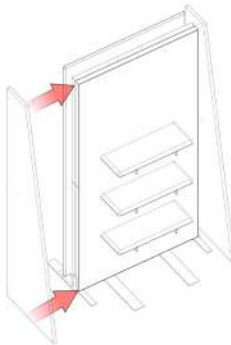

### Step 28.

Setup is COMPLETE



# Connection Methods

## Connection Method 1: CB9



First, insert the corner connector into the extrusion while holding in the lock button with the allen key tool. Second, slide the next extrusion onto the same corner connector while holding in the lock button using the allen key tool. Third, use the allen key tool for locking the corner connector buttons in place. Use the allen key tool to make half turns clock-wise. Do not over tighten the lock buttons.

## Connection Method 2: IB2



First, insert the in-line connector into the extrusion while holding in the lock button with the allen key tool. Second, slide the next extrusion onto the same in-line connector while holding in the lock button using the allen key tool. Third, use the allen key tool for locking the in-line connector buttons in place. Use the allen key tool to make half turns clock-wise. Do not over tighten the lock buttons.

## Connection Method 3: PH2

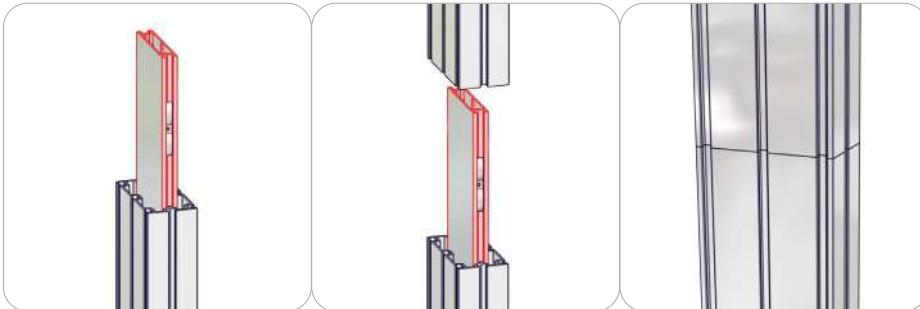

First, slide the PH2 connector into post until rest on the PH2 stop. Second, then slide the top post onto the PH2 connector.

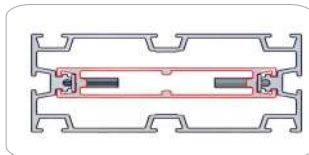

## Connection Method 4: CAM LOCK

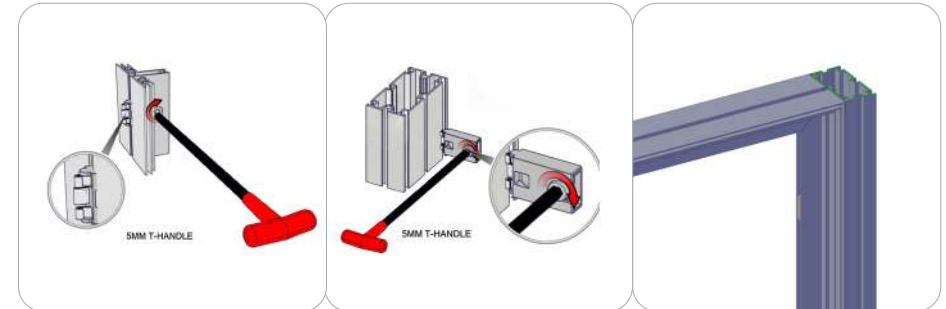

First, with the cam lock disengaged, place the cam lock teeth into the extrusion channel. Second, use the allen key tool to lock it in place. Make half turns clock-wise to engage the cam lock. Do not over tighten the lock buttons.

# Connection Methods

## Connection Method 5: PH1



First, with the cam lock disengaged, place the cam lock teeth into the extrusion channel. Second, use the allen key tool to lock it in place. Make half turns clock-wise to engage the cam lock. Do not over tighten the lock buttons.

## Connection Method 6: IB2/PH1 Application

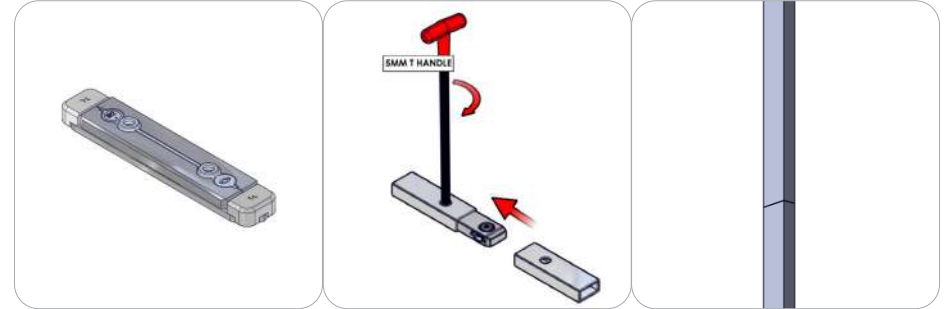

First, insert the silicone edge frame corners into the frame graphic channel (points 1 through 4). Second, insert the silicone edge frame sides into the frame graphic channel (points 5 through 8). Third, push the remaining silicone edge fabric into the frame graphic channel. Similar setup is recommended for the opaque liner. To remove these panels, simply pull the loop tag sewn near a corner.

## Connection Method 7: LN114-S2-650

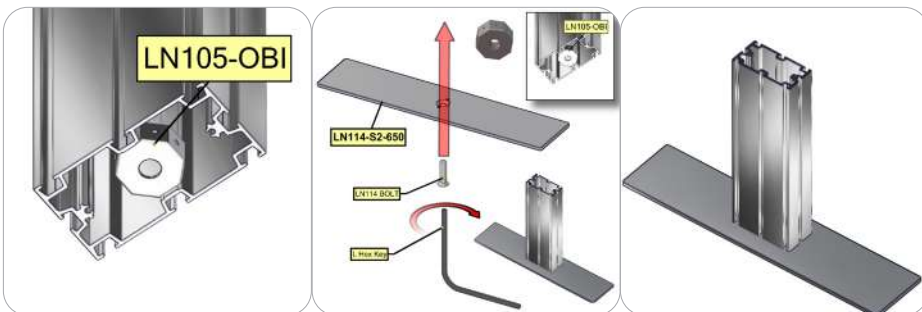

First, line up base plate screw hole with PM453 inside nut. Second, insert screw tighten til plate is snug or no movement. Do not over tight this can damage the extrusion or inside nut.

## Connection Method 8: Graphic Application

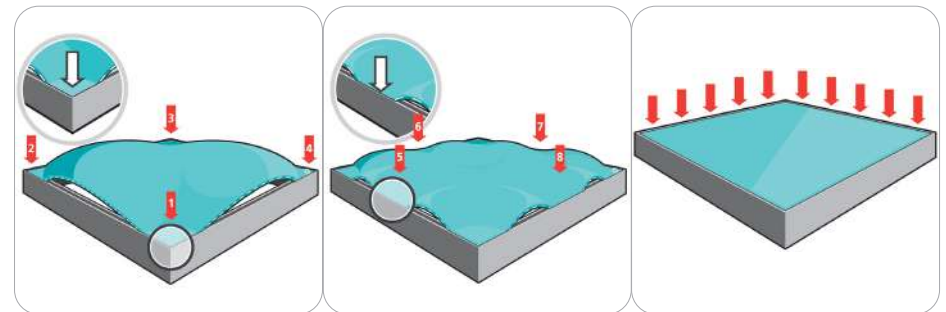

First, insert the silicone edge frame corners into the frame graphic channel (points 1 through 4). Second, insert the silicone edge frame sides into the frame graphic channel (points 5 through 8). Third, push the remaining silicone edge fabric into the frame graphic channel. Similar setup is recommended for the opaque liner. To remove these panels, simply pull the loop tag sewn near a corner.

# Connection Methods

## Connection Method 9: TC-30-D-ES50-S-ASY

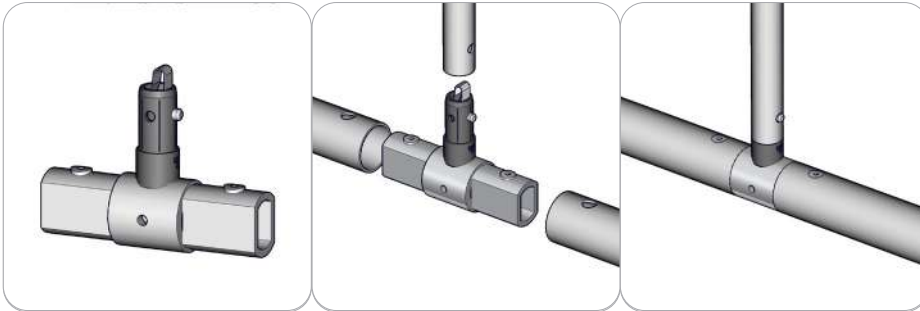

First, check if the connector ends compress. If they do not compress, use the allen key tool for turning the internal screw counter clockwise. Second, compress the connector end and slide it into the tube. Align the connector end button with the tube hole until it pops out. Third, use the allen key tool for turning the internal screw clockwise for a secure fit. Be sure to lock securely, but do not over tighten. Attach a snap button tube to the plastic connector.

## Connection Method 10: ES30 / ES50

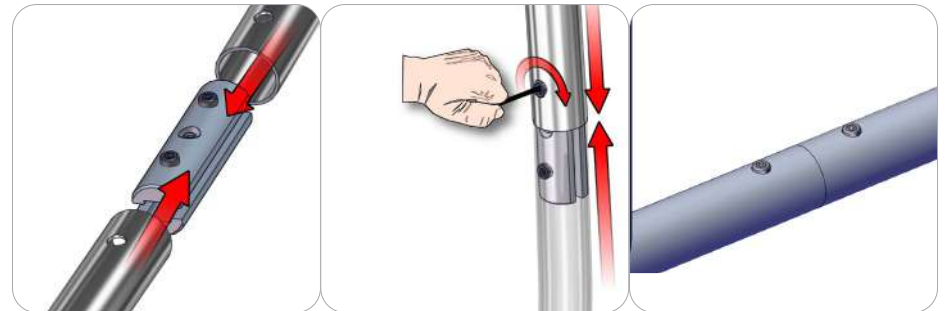

For spigot connections, compress the unlocked connector and slide into the tube lock access hole. Lock both screws carefully using your allen key tool. Be sure to lock securely, but do not over tighten. For snap button connections, locate the snap button on the connector or swage tube. Locate the hole on the corresponding tube. Press the snap button with your thumb and slide the tube and connector together so that the snap button snaps fully into the lock hole. To disassemble, press the snap button and pull apart.

## Connection Method 11: ATTACH GRAPHIC

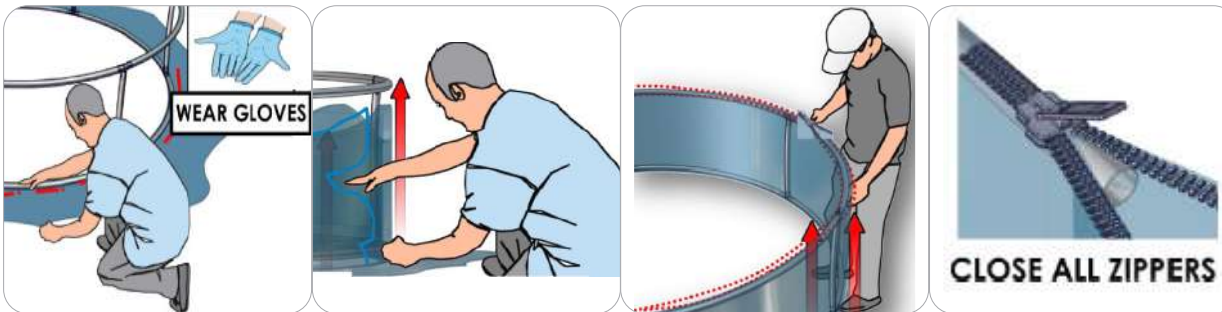

First, place cover around the bottom of frame. Recommend wearing gloves. Second, pull cover carefully up to the top. last, close zipper. adjust fabric around the frame, til wrinkles are gone. Besure to clear frame before and place on clear surface before adding graphic.

# Connection Methods

## Connection Method 12: ADT-CAM-SM

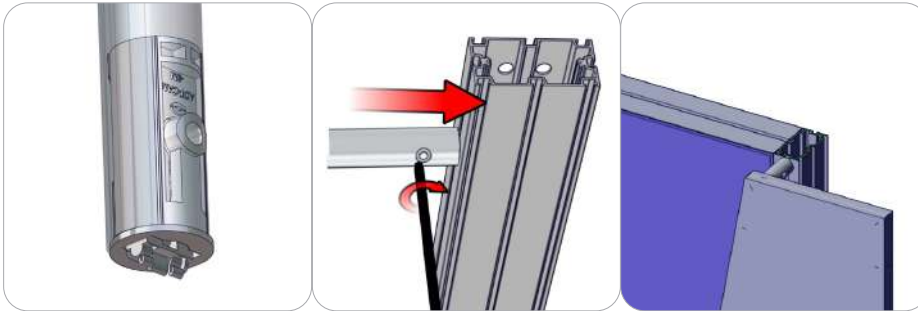

ADT-CAM-SM is already embedded inside tube. First, with the cam lock disengaged, place the cam lock teeth into the extrusion channel. Second, use the allen key tool to lock it in place. Make half turns clock-wise to engage the cam lock. Do not over tighten the lock buttons.

## Connection Method 13: ADT-CAM-SM

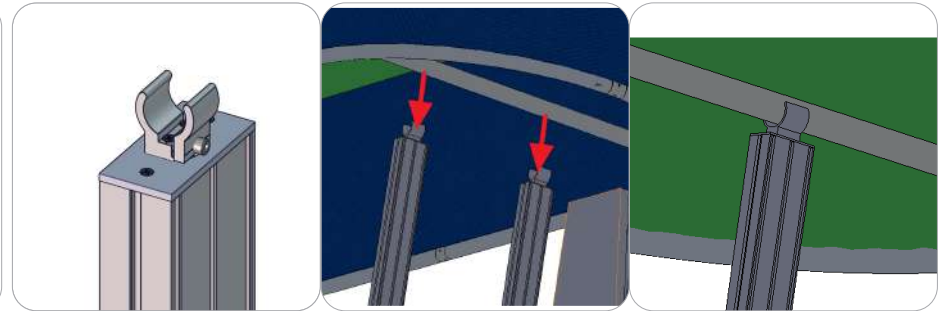

First, with assistance lift fabric structure over vector frames. A line the clamps with the inner tubes of the HP-FS-PILL. Second, once both are lined up, lower into place. The tubes should snap into place. Check to make sure structure is stable and nothing out of line. This could cause a wobbly structure.

## Connection Method 14: SW-FOOT-500

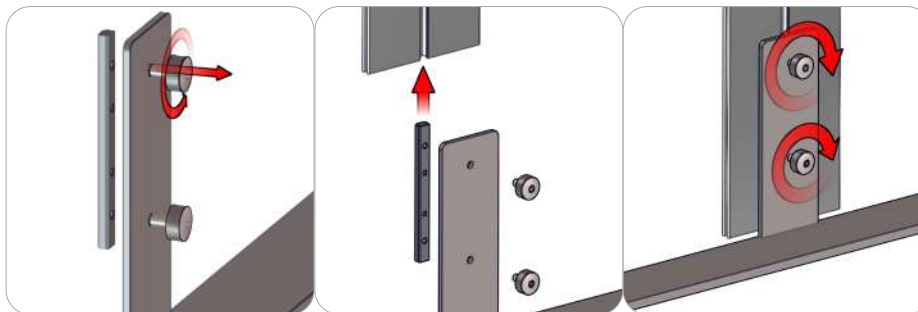

First, loosen the thumb screws and channel bars on the stabilizing bases. Do not disassemble them. Second, slide channel bars into the frame channel flush with the base of the frame. Third, tighten the thumb screws and channel bars securing the attachment. Do not over tighten the thumb screws.

# Freestanding Monitor Kiosk

PM4S3-MK-M  
PM4S3-MK-L

PM4S3-MK-M-MSHELF  
PM4S3-MK-L-MSHELF

PM4S3-MK-SHELF-UNIT

The Freestanding Monitor Kiosk is a superior multimedia display that can be used for multiple applications, as well as in trade show exhibits and for events. Kiosks include monitor mounts to support a medium or large size TV, and a corresponding medium or large shelf may be added. Monitor mounts support TV's up to 40 lbs and 32" - 70" in size, and can be adjusted to the perfect height; an included shelf can hold up to 15 lbs. The Shelf Unit is a great addition that proudly displays small products. Install the Freestanding line behind a fabric backwall for a truly impressive display.

Freestanding Monitor Kiosk



PM4S3-MK-M  
PM4S3-MK-L

Freestanding Monitor Kiosk with Shelf



PM4S3-MK-M-MSHELF  
PM4S3-MK-L-MSHELF

Freestanding Shelf Unit



PM4S3-MK-SHELF-UNIT

## features and benefits:

- Premium aluminum extrusion frames with cam lock and tension glide assembly
- Easy to store and ship
- Quick to set up
- Weighted feet for added stability
- Kits may include: a medium or large monitor mount, shelf, or combination
- Choice of medium or large monitor mount options. (Freestanding Monitor Kiosk with Shelf or Freestanding Shelf)
- Lifetime limited hardware warranty against manufacturer defects

## dimensions:

### Hardware

Assembled unit (no shelf):  
25.59" w x 70.98" h x 25.59" d  
650mm(w) x 1803mm(h) x 650mm(d)

Assembled unit (with shelf):  
29.53" w x 70.98" h x 25.59" d  
751mm(w) x 1803mm(h) x 650mm(d)

Approximate weight:  
(excludes cases & monitor mount)

40 lbs / 19 kg

Add 10 lbs / 5 kg for each shelf

### Shipping

Packing case(s):  
1 OCE Case

Shipping dimensions:  
OCE: Expandable case length (l) may vary  
40" - 66" l x 18" h x 18" d  
1016mm-1677mm(l) x 458mm(h) x 458mm(d)

Approximate total shipping weight:

Monitor Kiosk:  
(Case & monitor mount)

Medium  
83 lbs / 38 kg

Large  
85 lbs / 39 kg

## additional information:

-Medium monitor mount can hold 37-70" monitor/ max weight 40 lbs

-Large monitor mount can hold 40"-65" monitor/ max weight 40 lbs

-Monitor not included

-Shelf can hold suggested max weight: 15 lbs

-If shipping with backwall kit cases may vary

Monitor Kiosk with Shelf:  
(Case, monitor mount, & shelf)

Medium  
93 lbs / 43 kg

Large  
95 lbs / 44 kg

Shelf Unit:  
(Case & shelves)  
116 lbs / 53 kg

We are continually improving and modifying our product range and reserve the right to vary the specifications without prior notice. All dimensions and weights quoted are approximate and we accept no responsibility for variance. E&OE. See Graphic Templates for graphic bleed specifications.



# Included In Your Freestanding Monitor Kiosk

Tools, Components, Connectors & Extrusions



5MM ALLEN-T x1

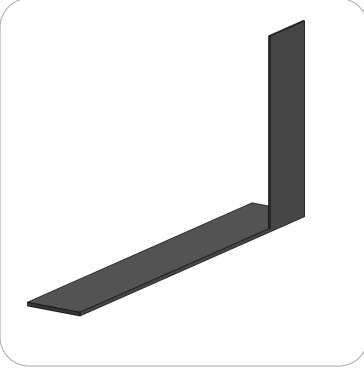

PM4S3-MM-FOOT-L x1



PM4S3-MM-FOOT-R x1



LN100 x6

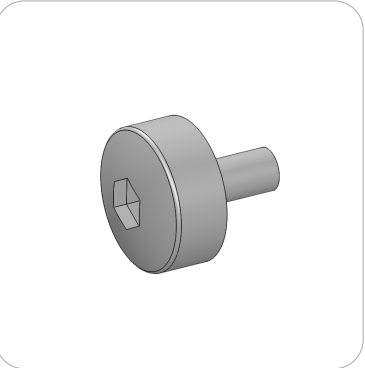

M5 THUMBSCREW x8



PH2-350-L-L x3



PH5-100-L-L x2



PM4S4-150 x2



PM4S3-600-A165-A165 x2



PM4S3-1200-A165-A165 x2



PH2-300-TG x2



EXT-M-MB (or) EXT-LG-MB x1  
Fastening Hardware Included



CBE-50 x2



# Included In Your Freestanding Monitor Kiosk with Shelf

Tools, Components, Connectors & Extrusions



5MM ALLEN-T x1



PM4S3-MM-FOOT-L x1

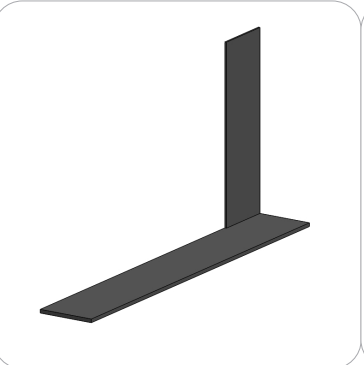

PM4S3-MM-FOOT-R x1



LN100 x6

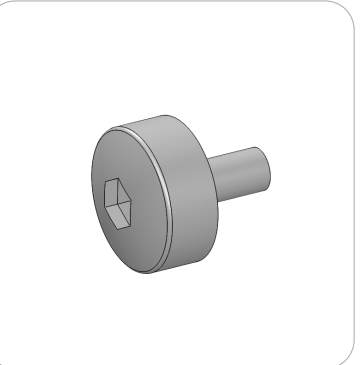

M5 THUMBSCREW x8



PH2-350-L-L x3



PH5-100-L-L x2



PM4S4-150 x2



PM4S3-600-A165-A165 x2



PM4S3-1200-A165-A165 x2



PH2-300-TG x2



EXT-M-MB (or) EXT-LG-MB x1  
Fastening Hardware Included



CBE-50 x4



# Included In Your Freestanding Monitor Kiosk with Shelf

Components, Connectors & Extrusions



PH-400-L-SIDE-MK x2

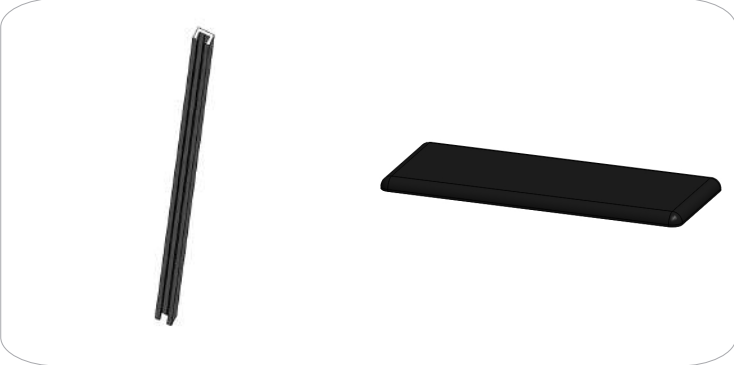

PE-1200 x2  
\*will ship preattached to shelf



CT21-MK-SHELF x1



LN605-EN x2



# Included In Your Freestanding Shelf

Tools, Components, Connectors & Extrusions



5MM ALLEN-T x1

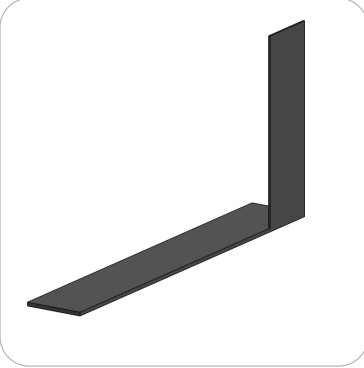

PM4S3-MM-FOOT-L x1



PM4S3-MM-FOOT-R x1



LN100 x6

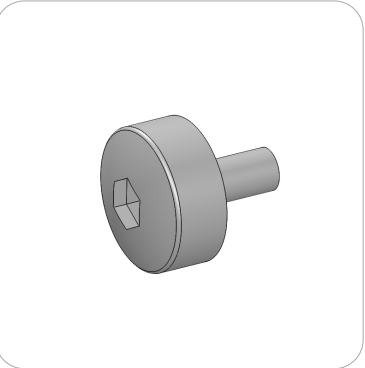

M5 THUMBSCREW x8



PH2-350-L-L x3



PM4S3-600-A165-A165 x2



PM4S3-1200-A165-A165 x2



PH2-300-TG x2



PH-400-L-SIDE-MK x6



PE-1200 x6  
\*will ship preattached to shelf



CT21-MK-SHELF x3



LN605-EN x6



# Exploded View

## PM4S3-MK-M PM4S3-MK-L

Please note:  
This is the kiosk frame build for  
either medium or large kit.

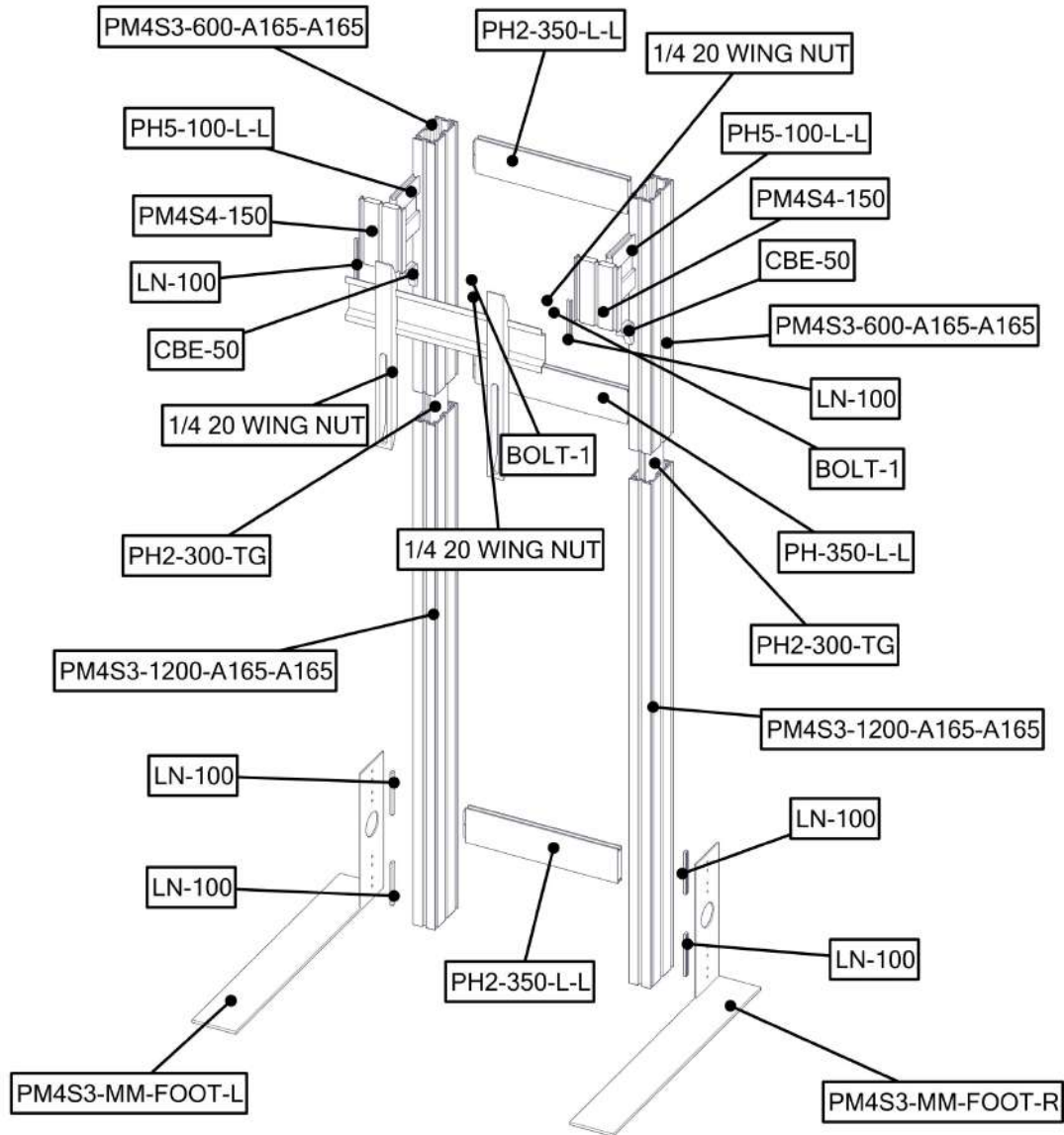

# Exploded View

## PM4S3-MK-M-MSHELF PM4S3-MK-L-MSHELF

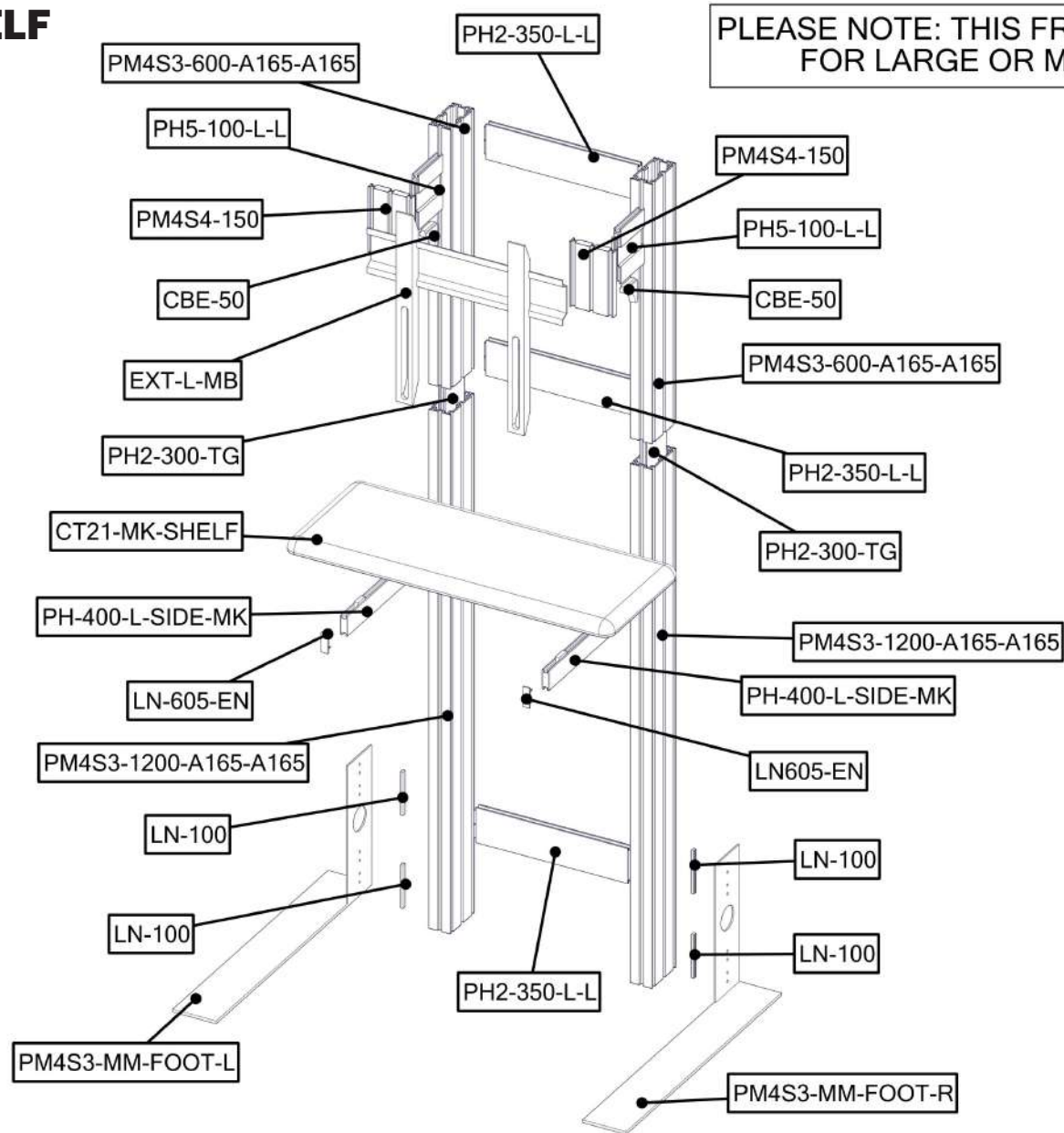

# Exploded View

## PM4S3-MK-SHELF-UNIT

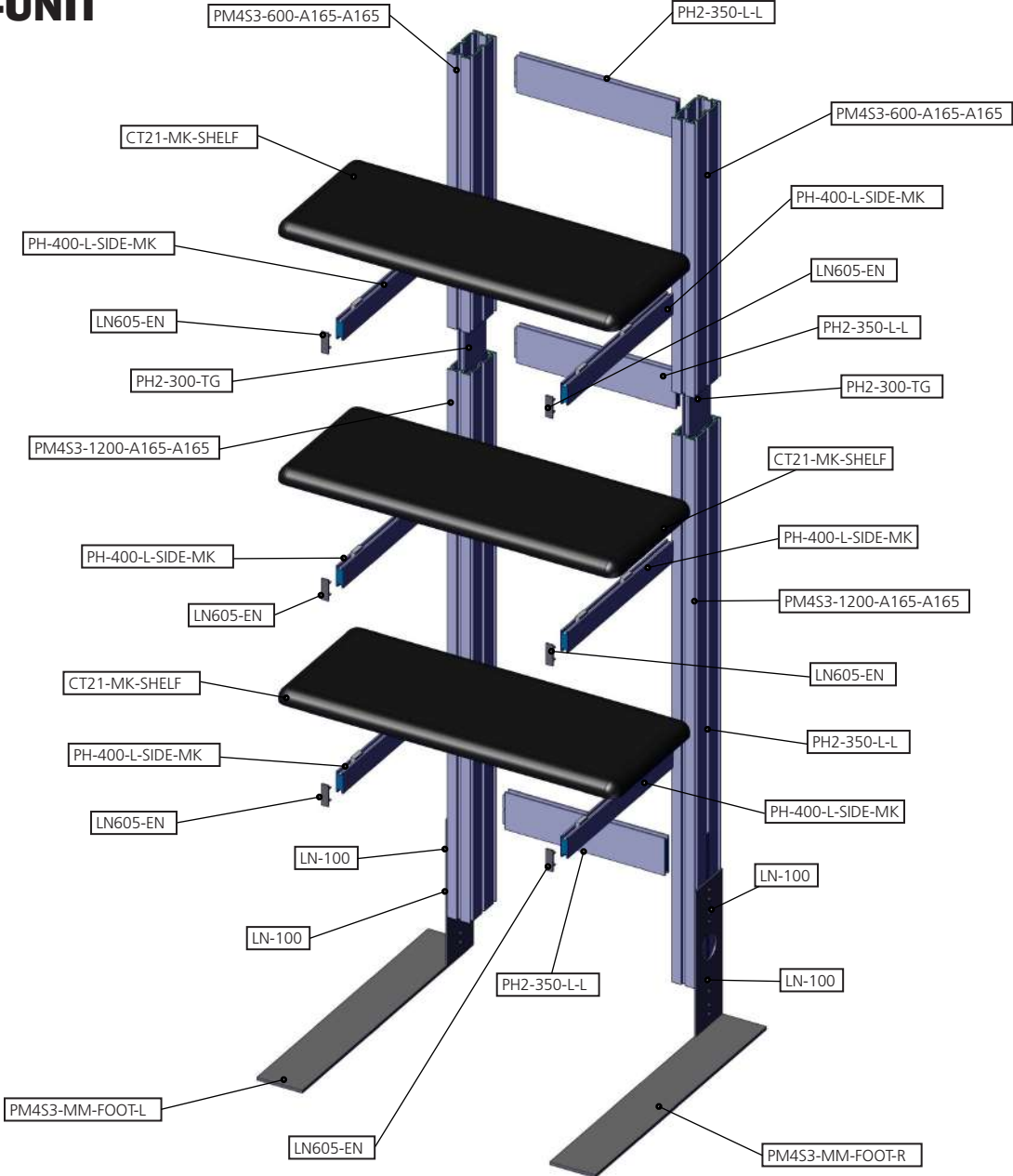

# Kit Assembly

## Step by Step

### Step 1.

Reference the image to the right. Locate the coded extrusions. Slide the PH2-300-TG connector into one end of the PM4S3-1200-A165-A165 so that it goes as deep as the internal pins. Connect the PM4S3-600-A165-A165 by sliding it over the PH2-300-TG. Repeat for this step for the second vertical.

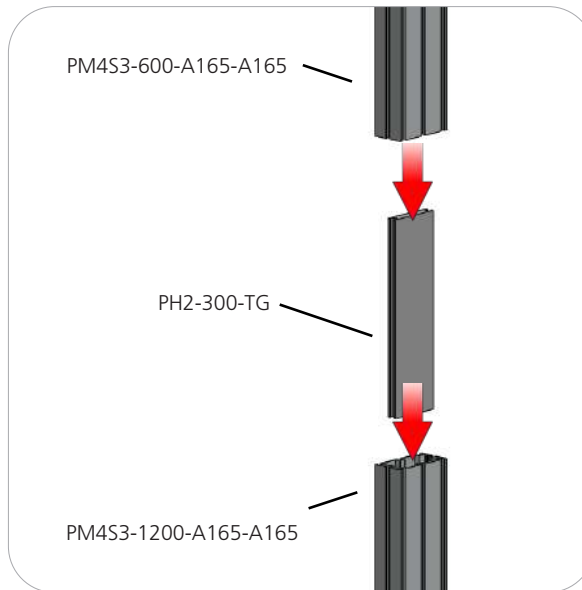

### Step 2.

Collect your extrusions and handtool. Using the provided handtool, lock the extrusions into the back channel of the three channel PM4S3 faces as shown in the image below. Be sure the locks face toward the back of the assembly and do not over tighten.

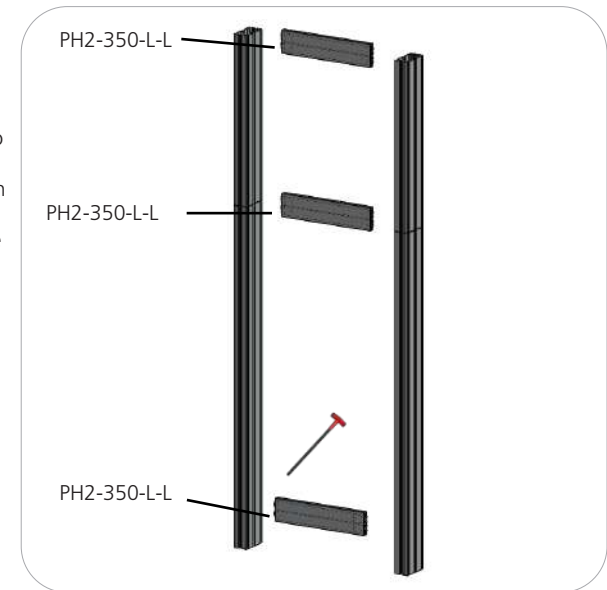
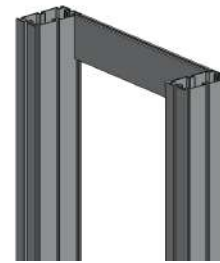

### Step 3.

Locate the M5 thumbscrews, LN100s, and the PM4S3-MM stabilizing bases. Slide the LN100s into the middle channel of the PM4S3. Hand screw the M5 thumbscrews through the base holes and into the LN100 holes. Use the handtool to securely fasten the M5 Thumbscrews. Do not over tighten.

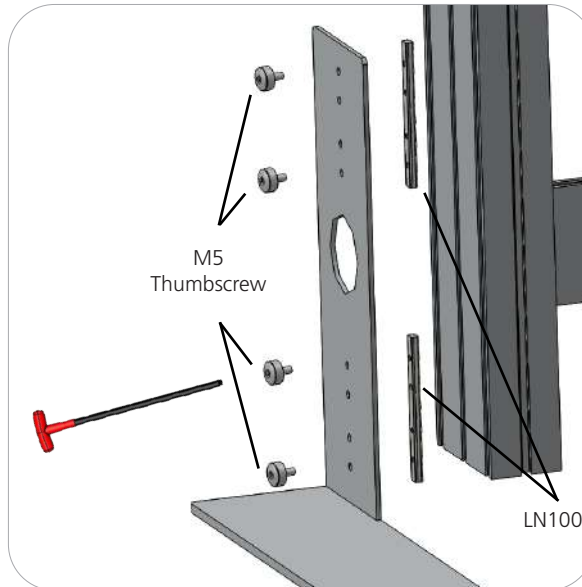

### STOP

Orbus recommends that you move your kiosk(s) in place before continuing on with the rest of assembly.

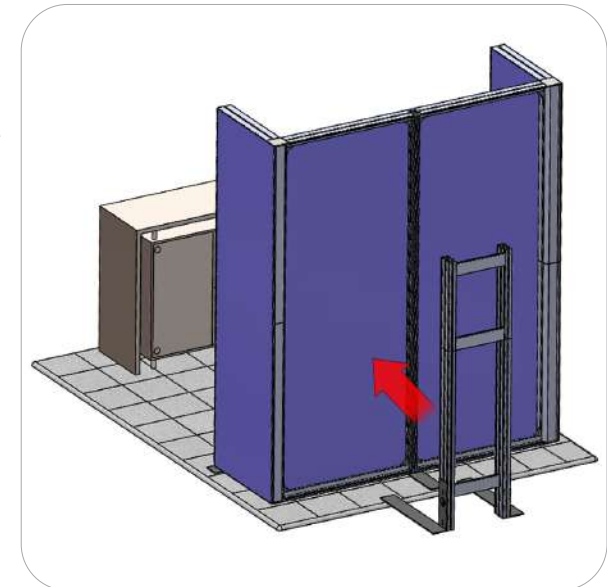



# Kit Assembly

## Step by Step - Monitor Mount

### Step 4.

This step is for kiosks with monitor mounts. Skip to step 7 for shelf kiosks.

Measure from the ground to the center of the hole in your main kit's graphic. Lock the center of your PH5-100-L-L into the PM4S3 stacks at the dimension height of the graphic hole, ADD CBE-50 for support under PH5. Do not over tighten.

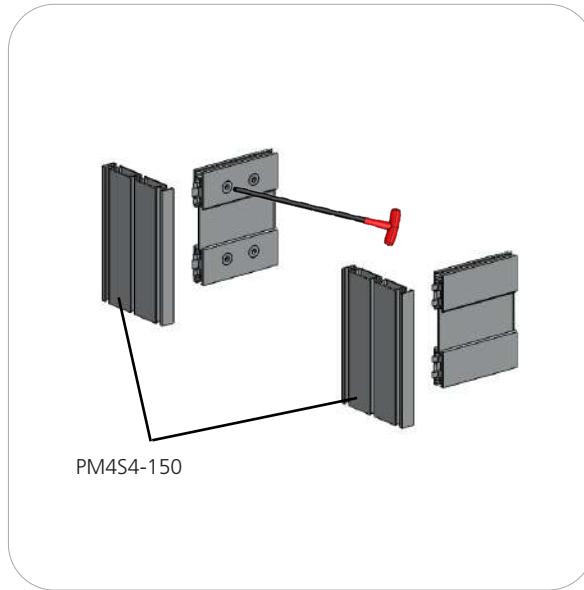

### Step 5.

NOTE: Your main backwall assembly must be completed with graphics before completing this step of the monitor kit.

Lock your PM4S4-150 to the ends of the PH5-100-L-L. Do not over tighten.

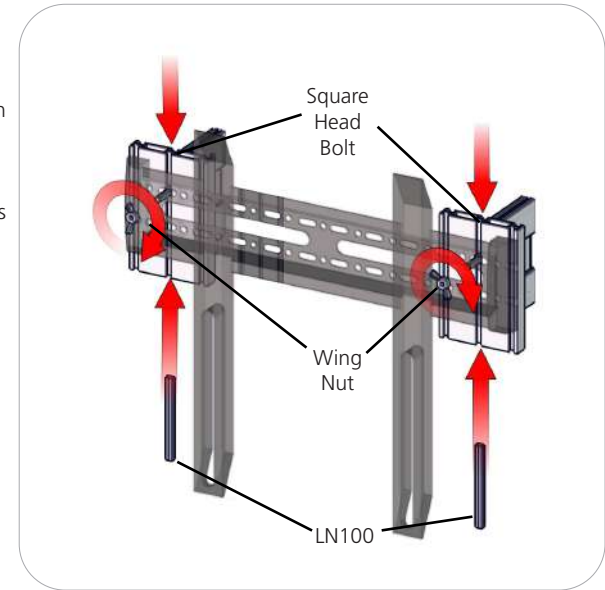

### Step 6.

Set your monitor stand so that the extrusion arms fit through the graphic hole. Use the provided fastening hardware to complete your monitor stand. Slide the LN100 into the bottom center channel of the PM4S4-150. Next, slide the Square Head Bolt into the top center channel of the PM4S4-150. Apply the monitor bracket and spacer washer before fastening with the wingnut. Monitor mount may vary depending on size. Monitor not included.

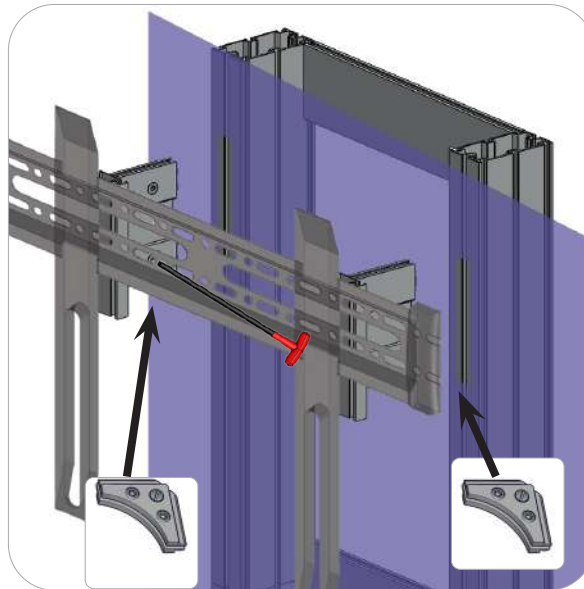

**ATTACH CBE-50 UNDER PH5 FOR SUPPORT**

# Kit Assembly

## Step by Step - Shelf

### Step 7.

Insert the LN605-EN end caps. Lock the CT21-MK-SHELF to the PH-400-L-SIDE-MK. Do not over tighten.

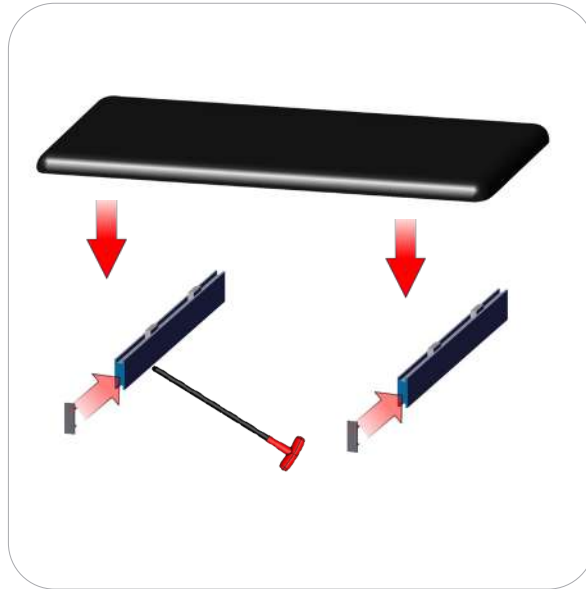

### Step 8.

Lock your PH-400-L-SIDE-MK into the PM453 stacks at the desired dimension height. Do not over tighten.

Refer to the attached supplemental sheet for details on shelf height(s).

Setup is complete.

Repeat steps 7 and 8 twice more for Shelf Unit.



# Freestanding Display Shelf

## PM4S3-MK-SHELF

Freestanding display shelves are easily attached to your assembled kiosk for displaying promotional materials. This shelf can be added to a Freestanding Monitor Kiosk order.

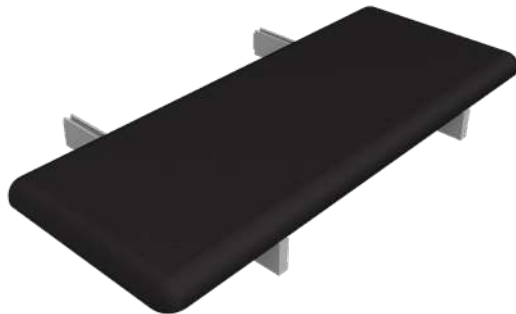

### features and benefits:

- Premium aluminum extrusion frames with cam lock and tension glide assembly
- Easy to store and ship
- Quick to set up
- Lifetime limited hardware warranty against manufacturer defects
- Great for display opportunities

### dimensions:

Hardware	Shipping
<p>Assembled unit: Medium or Large</p> <p>29.53" w x 6.35" h x 15.87" d 751mm(w) x 162mm(h) x 404mm(d)</p> <p>Approximate weight (shelf): 10 lbs / 5 kg</p>	<p>Ships in box</p> <p>Shipping dimensions: Special order - 30" (l) x 16" (h) x 4" (d) 762mm(l) x 407mm(h) x 102mm(d)</p> <p>Approximate total shipping weight: 12 lbs / 6 kg</p>
additional information:	
<p>-Shelf can hold suggested max weight 15 lbs</p> <p>-If shipping with backwall kit cases may vary</p>	

We are continually improving and modifying our product range and reserve the right to vary the specifications without prior notice. All dimensions and weights quoted are approximate and we accept no responsibility for variance. E&OE. See Graphic Templates for graphic bleed specifications.

# Included In Your Freestanding Display Shelf

Components, Connectors & Extrusions



PH-400-L-SIDE-MK x2



PE-1200 x2  
\*will ship preattached to shelf



CT21-MK-SHELF x1



LN605-EN x2



# Exploded View

## PM4S3-MK-SHELF

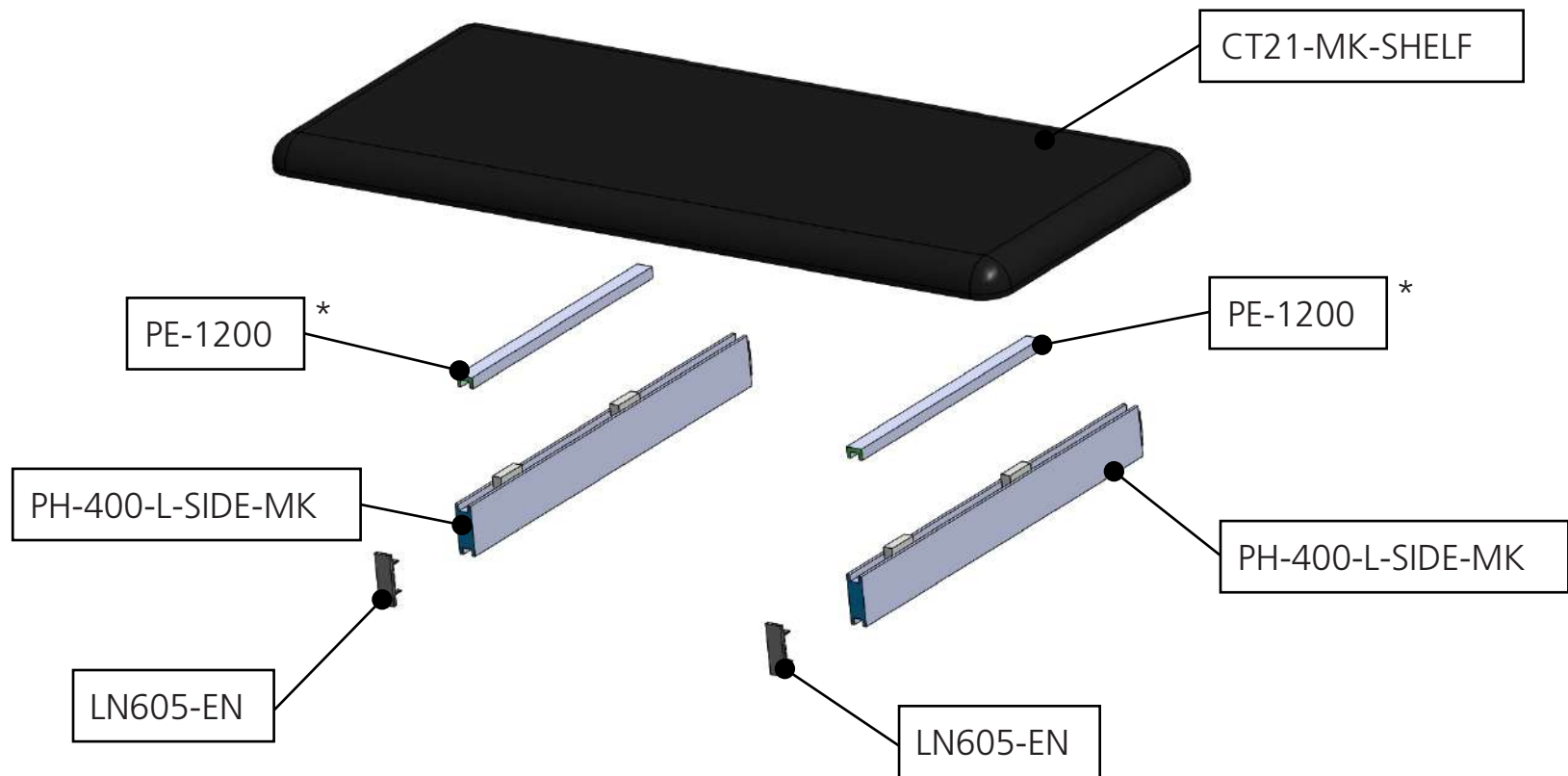

\*Note: PE will ship preattached to shelf

# Kit Assembly

## Step by Step - Shelf

### Step 8.

Insert the LN605-EN end caps. Lock the CT21-MK-SHELF to the PH-400-L-SIDE-MK. Do not over tighten.

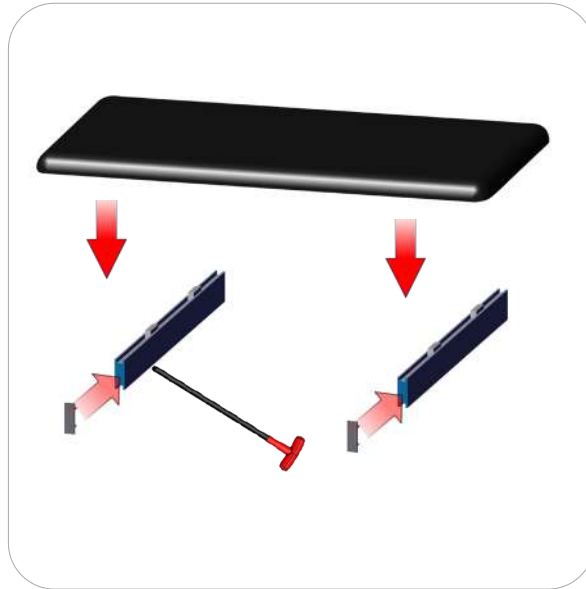

### Step 7.

Lock your PH-400-L-SIDE-MK into the PM453 stacks at the desired dimension height. Do not over tighten.

Refer to the attached supplemental sheet for details on shelf height(s).

Setup is complete.

Repeat steps 7 and 8 twice more for Shelf Unit.



Location of vinyl adhesive tape  
Tape color-**CLEAR**

Indicator shown in green to show detail

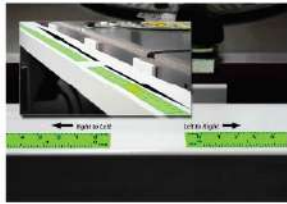

**TORQUATA**  
**Self-Adhesive Measuring**  
**Tape**

Note: tape comes preattached to extrusion,  
0" starts from the bottom (at the floor)

