

Formulate Accent - 04

FMLT-WL04

Formulate® accents enhance the functionality of any 10ft or 20ft backwall and add more real estate for messaging too! With monitor supports, literature pockets, shelves, tables, counters and more, you are sure to find the accent that best suits your needs. Side tables and graphic headers also available.



features and benefits:

- State-of-the-art brushed 30mm aluminum tube frame with expanding spigot connection
- Features a 34" wide counter available in four laminate color options
- Hardware mounts for a small sized monitor, max 37"/ 40 lbs
- Kit includes: one frame, top and bottom velcro applied printed fabric graphics, monitor mount, counter, and one wheeled molded OCH2 storage case
- Lifetime hardware warranty against manufacturer defects

dimensions:

Hardware	Graphic
Assembled unit: 37.4"w x 92.4"h x 29.4"d 950mm(w) x 2347mm(h) x 747mm(d)	Refer to related graphic template for more information.
Approximate weight with cases: 57 lbs / 25.8 kgs	Visit: www.exhibitors-handbook.com/graphic-templates

Shipping	additional information:
Packing case(s): 1 OCH2 Case	Graphic material: dye-sublimated fabric
Shipping dimensions: OCH2: 52"l x 30"w x 14"h 1321mm(w) x 762mm(h) x 356mm(d)	Counter top dimensions: 34.6"l x 16.6"w 879mm(w) x 422mm(h) Counter top holds max 25 lbs / 11.3 kgs
Approximate total shipping weight (includes cases & graphics): 58 lbs / 26.3kgs	Monitor mount: max T.V. size is 37"/ 40 lbs *Kit does not include monitor
	When included in a larger kit, a different packaging solution will be listed to accommodate all contents of the kit. Individual packaging no longer provided.

Wood Finish Options



We are continually improving and modifying our product range and reserve the right to vary the specifications without prior notice. All dimensions and weights quoted are approximate and we accept no responsibility for variance. E&OE. See Graphic Templates for graphic bleed specifications.

Included In Your Kit

Tools, Components, & Connectors



ALLEN KEY SET x1



ES30 x11



PLT-BP-WC x2



THUMB-SCREW-5-8 x4



TUBE-SM-MB x1



CT-WL04 x1



TCP-3030 x2

Graphics

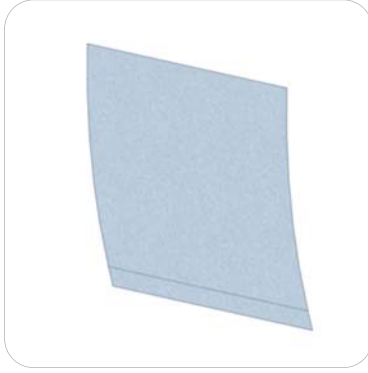

FMLT-WL04-B-G x1



FMLT-WL04-T-G x1

Included In Your Kit



WL04-T1 x1



RWL04-T1 x1



WL04-T2 x1



RWL04-T2 x1



WL04-T3 x1

Tubes



WL04-T4 x1



WL04-T5 x1



WL04-T6 x1



WL04-T7 x1

Exploded View

FMLT-WL04

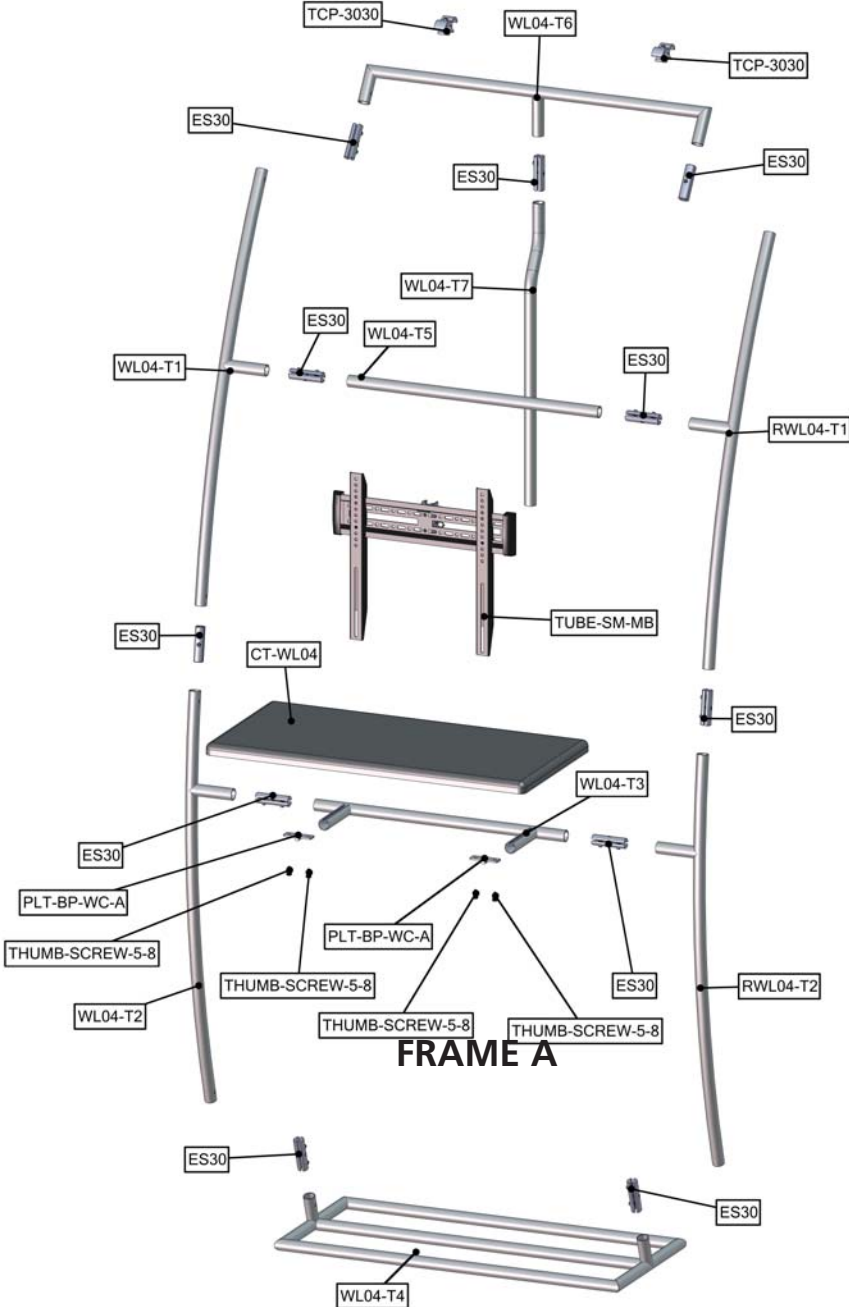

Connection Methods

Formulate® structures use a number of different yet simple connection methods. Your kit will include one or more of the connection methods shown below. Steps within the Kit Assembly will reference a specific method for each connection point.

Connection Method 1: ES30 / ES50 / ES75

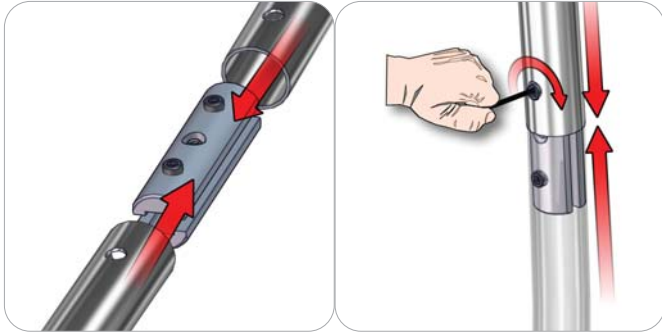

Compress the unlocked connector and slide one tube onto each end. Lock both screws carefully using your allen key tool. Be sure to lock securely, but do not overtighten.

Connection Method 2: Snap Buttons & Swage

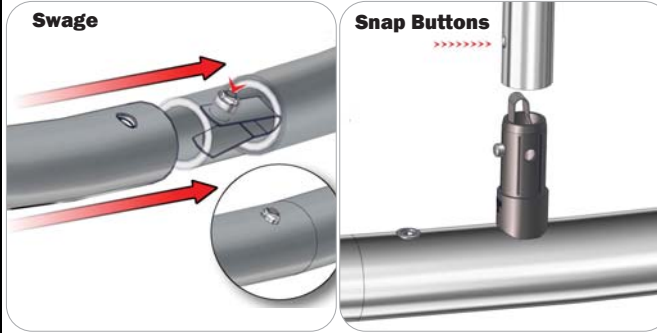

Locate the snap button on the connector or swage tube. Locate the hole on the corresponding tube. Press the snap button with your thumb and slide the tube and connector together so that the snap button snaps fully into the lock hole. To disassemble, press the snap button and pull apart.

Connection Method 3: ES30-90B / ES30-I / ES30-C

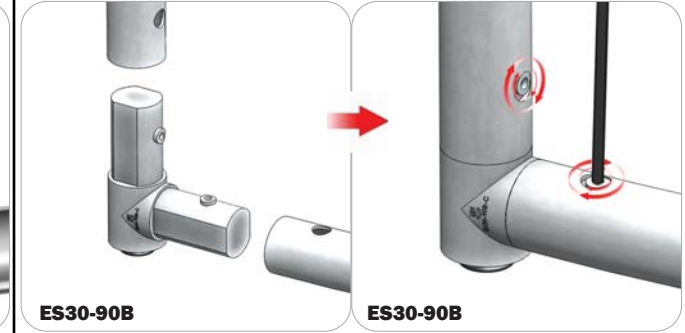

Compress one unlocked end of the connector and slide it through one tube end. Compress the other end of the connector and slide the second tube on. Lock both screws carefully using your allen key tool. Be sure to lock securely, but do not overtighten.

Connection Method 4: Tube Clamps

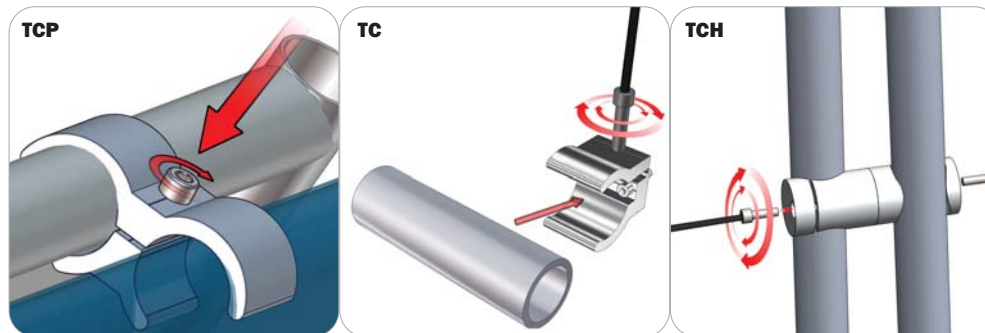

Be sure to fully assemble all frames before using clamps. With the clamp unlocked, place one tube of the first frame into the mouth of the clamp. Place the second tube (if applicable) into the second mouth of the clamp. With both frame's tubes in the clamp, be sure to lock securely, but do not overtighten.

Kit Assembly

Step by Step

Step 1.

Gather the components necessary for assembling Frame A. Assemble in order according to the Labeling Diagram.

Please reference Connection Method 1 for more details.

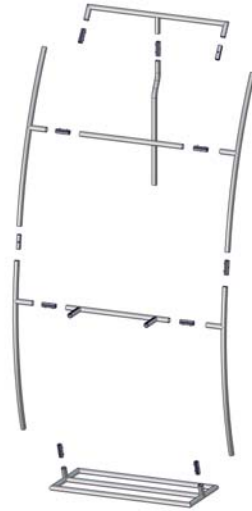

Step 2.

Locate your counter top brackets and fastening hardware. Using your allen key set tool, attach the bracket set screw into the channel of the tube supports.

Do not over tighten.



Step 3.

Locate your counter top and thumb screws. Locate the screw holes under the counter top. Fasten the counter top onto the brackets.

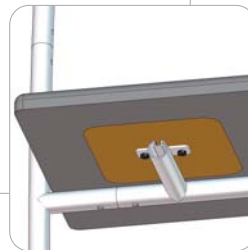
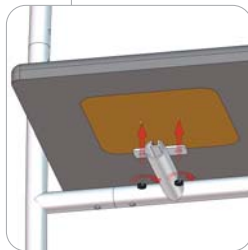

Step 4.

Locate your monitor mount brackets and fastening hardware.

Please reference the Monitor Bracket Supplement Sheets for more details.



Kit Assembly

Step by Step

Step 5.

Apply the top and bottom graphic panels onto the tube hardware using the provided velcro.



Step 6.

Locate your tube clamps. clamp your ladder onto the top of your backwall. Finish installing your monitor onto the monitor bracket.

Please reference Connection Method 4 for more details.

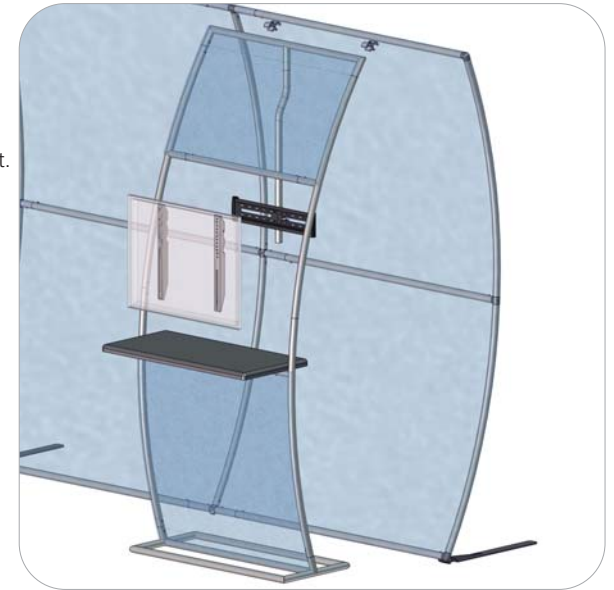
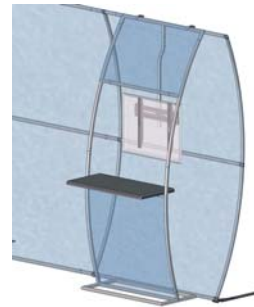

Monitor Bracket Instructions

Tube Applications



TUBE-SM-MB
Sizes: 17" - 37"
Max weight varies per application



TUBE-M-MB
Sizes: 32" - 55"
Max weight varies per application



TUBE-LG-MB
Sizes: 40" - 65"
Max weight varies per application

Included hardware:

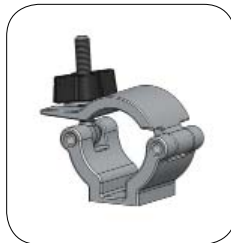

ACC60 x2



TCH-30 x2

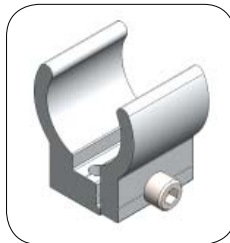

TC-30MM-SILVER x2



BOLT-1 x4



Flange Wingnut x4

TUBE CONNECTION

ACC60 Clamp Connection

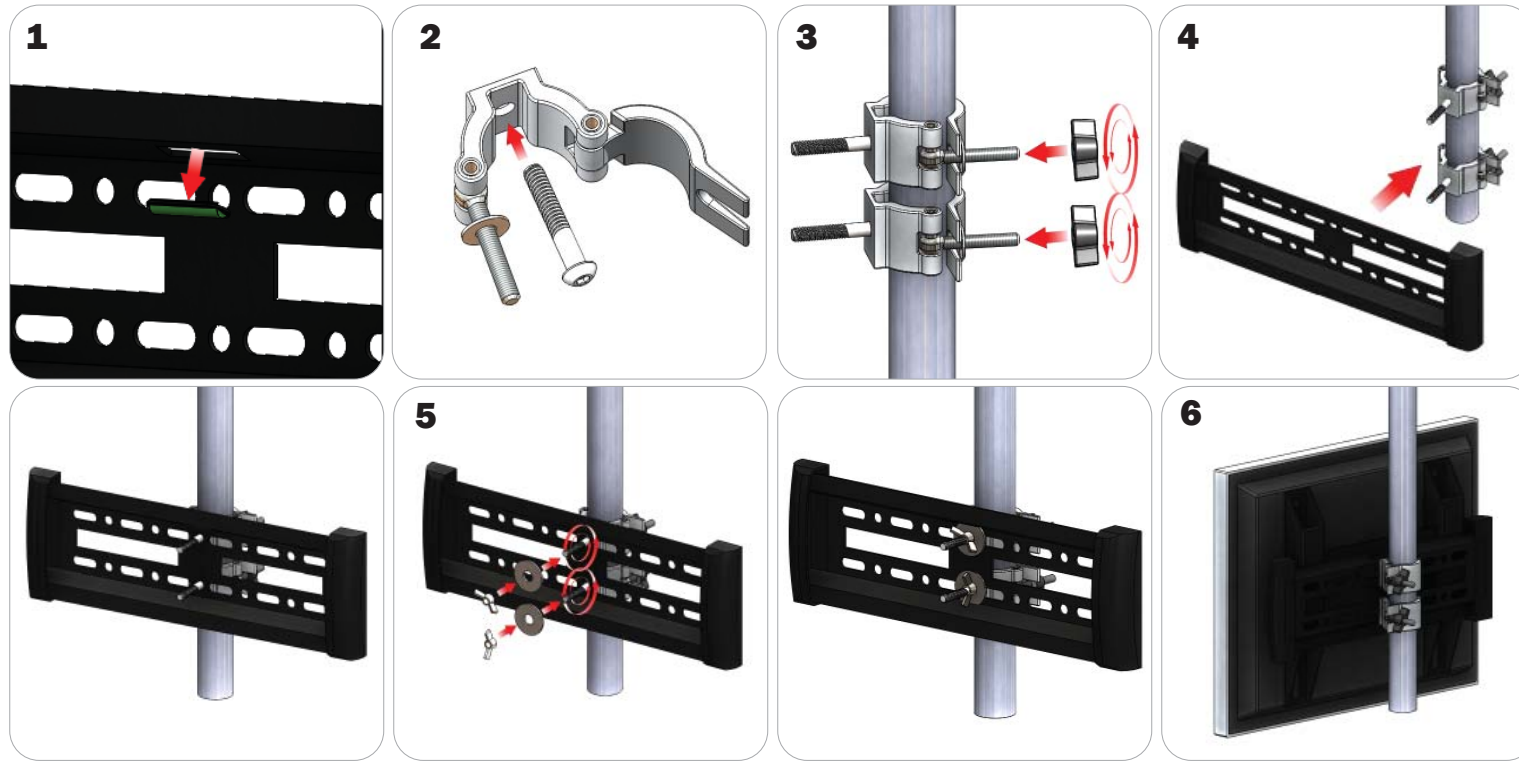

Locate all components needed to assemble the monitor mount with the ACC60 tube method. You will need (1) monitor bracket, (2) ACC60 clamps, (2) washers, and (2) wingnuts. **Step 1:** Apply pressure to the rear side of the leveling gauge clipped into the monitor mount to remove it. **Step 2:** Push the provided bolt through the hole in the ACC60 and place the ACC60 in the desired location. **Step 3:** Tighten the clamp to the tube using the plastic wingnut. **Step 4:** Set your monitor bracket onto the protruding bolts using the of the ACC60 using the center holes on the monitor bracket., adjust ACC60 position if necessary. **Step 5:** Lock your monitor bracket to the ACC60s by placing your washers and locking with provided wingnuts. **Step 6:** Reference the included manufacturer monitor mount instructions for fastening your monitor to the bracket.

TCH Clamp Connection (Tablet Stands)

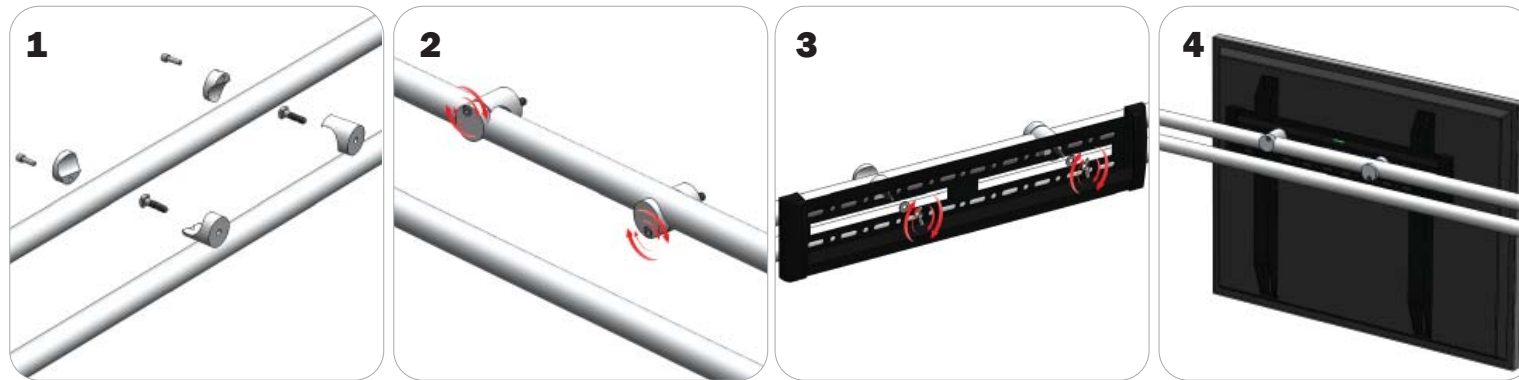

Locate all components needed to assemble the monitor mount with the TCH tube method. You will need (1) monitor bracket, (2) TCH clamps, (2) bolts, (2) washers, and (2) wingnuts. Determine your desired monitor location. **Step 1:** Fit the provided bolts through the TCH clamps then reassemble the clamp. **Step 2:** Lock the clamp onto the tube with the allen head screws on the clamp. **Step 3:** Align your monitor bracket so that the left and right holes slide onto the bolts behind them. Use your washers and wingnuts to lock your monitor bracket in place. **Step 4:** Reference the included manufacturer monitor mount instructions for fastening your monitor to the bracket.

TUBE CONNECTION

TC-30 Clamp Connection



Locate all components needed to assemble the monitor mount with the TC-30 tube clamp method. You will need (1) monitor bracket, (2) TC-30-SILVER clamps, (4) BOLT-1 screws, and (4) flange wingnuts. **Step 1:** Insert the pan-head screws through the holes of your TC-30 clamps. Attach the TC-30 clamps to the tubes but do not tighten. **Step 2:** Set your monitor bracket onto the protruding pan-head screws on your clamps using the holes in the monitor bracket. **Step 3:** Apply your flange wingnuts to the front of your monitor bracket to lock it to the clamps. Lock your clamps securely into place. **Step 4:** Reference the included manufacturer monitor mount instructions for fastening your monitor to the bracket.