

2023 | PROSUMER MOUNTING SOLUTIONS

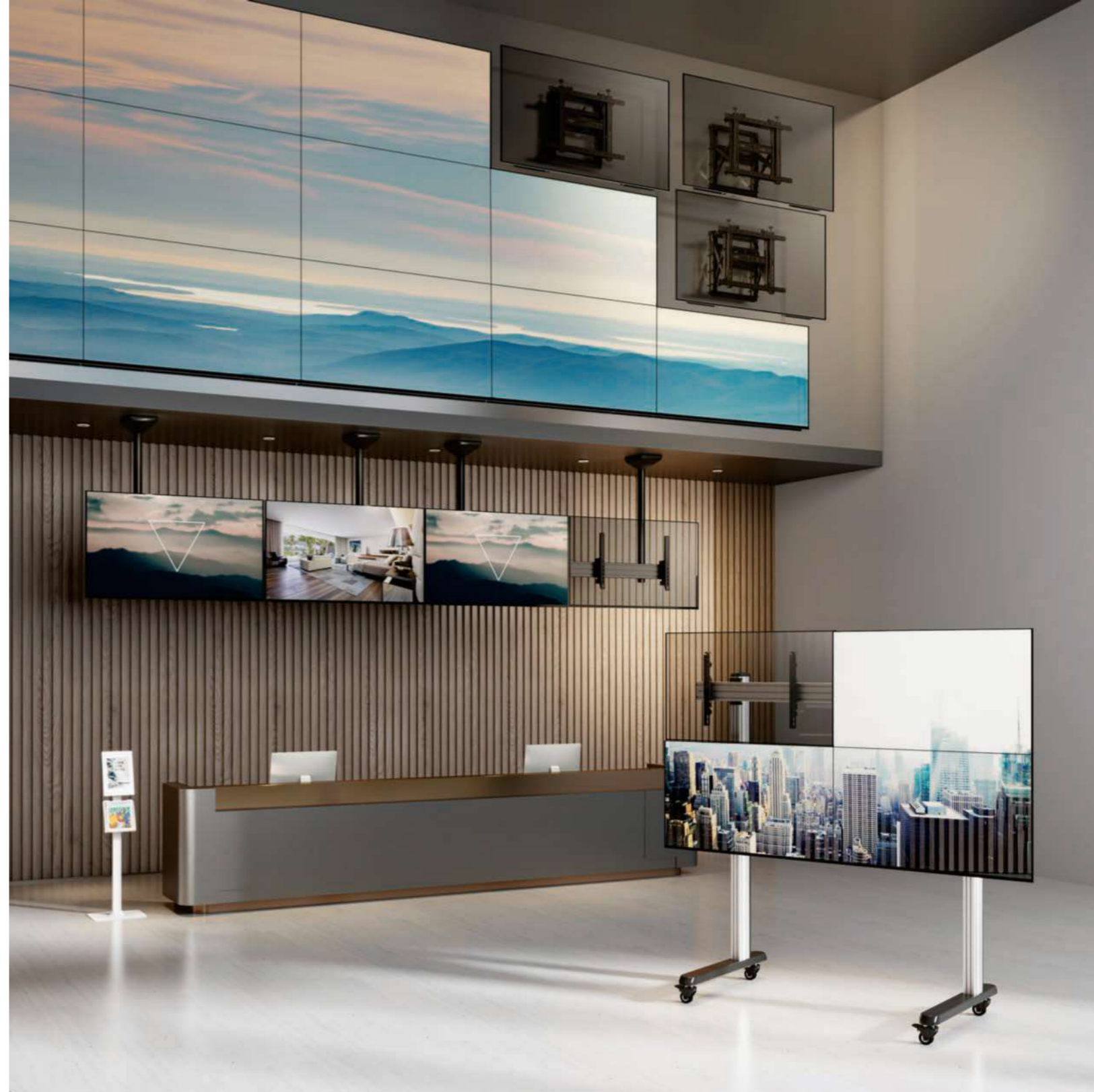

Edition 10



PROSUMER MOUNTING SOLUTIONS

WWW.XOXOO.CO



WWW.XOXOO.CO

Tel: +65 9622 6641

Email: sales@xoxoo.co

Add: 202 Kallang Place #08-02 Singapore 339339



XoXoo



@shopxoxoo



@shopxoxoo

2023

PRODUCTS

BY CATEGORIES

DIGITAL SIGNAGE DISPLAY MOUNTS

VIDEO WALL MOUNTS

- A03 Video Wall Mounts
- A09 Video Wall Ceiling Mounts
- A12 Video Wall Carts & Stands
- A20 Accessories

MENU BOARD MOUNTS

- B05 Aluminum Menu Board Wall Mount
- B06 Aluminum Menu Board Ceiling Mount

INTERACTIVE DISPLAY MOUNTS & STANDS

- C31 C37 Interactive Whiteboard Stand & Carts
- Interactive Whiteboard Wall Mounts

MODULAR SOLUTIONS FOR DIGITAL SIGNAGE DISPLAYS

- D03 D05 D09 D11 Solutions Overview
- D15 D16 Ceiling-Mounted Solutions
- Wall-Mounted Solutions
- Mobile & Fixed Solutions Additional Accessories Components Overview

TV CARTS & STANDS

- TV Carts & Stands

PROJECTOR MOUNTS

- E03 E05 E06 E08 Floor Stands
- Projector Wall Mounts
- Projector Ceiling Mounts
- Projector Risers

ANTI-THEFT TABLET MOUNTS

- F04 F07 Universal Anti-Theft Tablet Mounts
- Universal Anti-Theft Tablet Mounts for iPad & Samsung Galaxy

POS MOUNTS

- F16 F19 F20 One POS Mounting System
- POS Terminal Stand
- POS Stands for Tablet & Printer

INDEX

A | PUBLIC VENUES



1 VIDEO WALL MOUNT A03

2 VIDEO WALL CEILING MOUNT A09

3 VIDEO WALL CART A12

MORE RECOMMENDED PRODUCTS



LVW13-46T



LVC03-FL Series



LVS02 Series



4 TABLET KIOSK F10
PAD32 Series

LVW13-46T

Optimal Full Service Video Wall Mount

Easy to configure, quick to install, convenient to

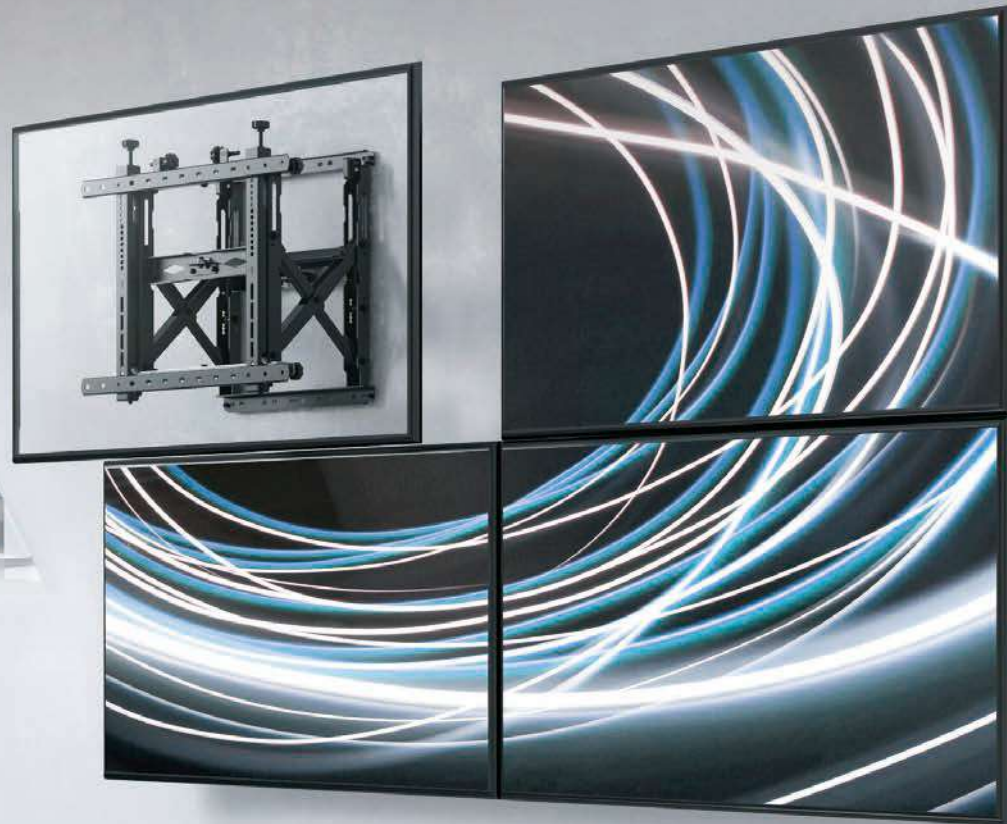

OPTIMAL FULL SERVICE VIDEO WALL MOUNT

LVW13-46T

 **Tool-Free Display Alignment**
for seamless digital signage



Tilt Range

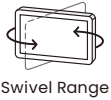

Swivel Range



Screen Level



Depth Adjustment

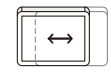

Lateral Adjustment

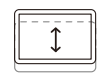

Height Adjustment

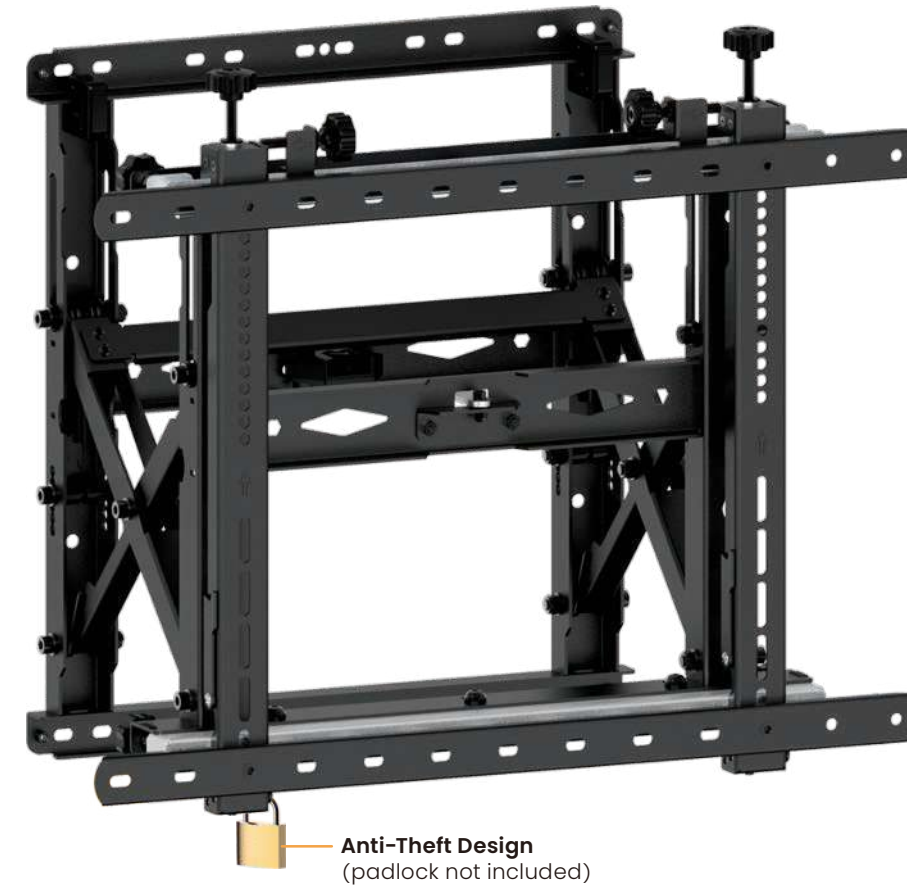

Anti-Theft Design
(padlock not included)

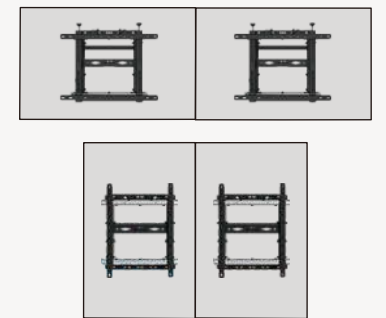

Portrait or Landscape Orientation
for different viewing experience

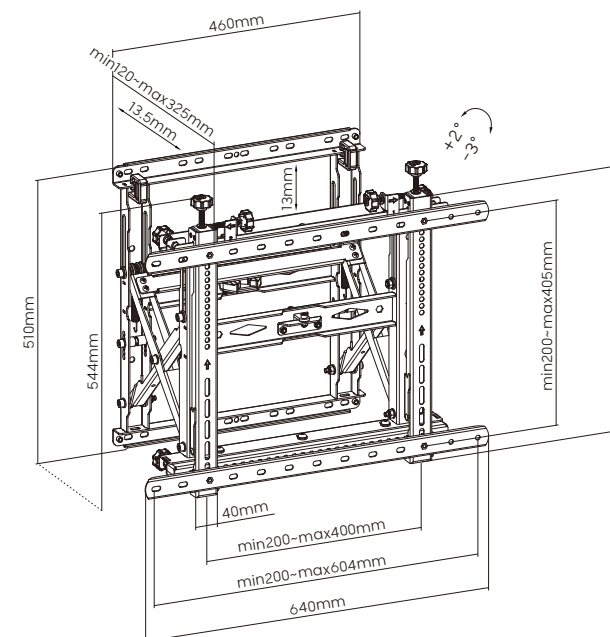

Kick-Stands
offers space for easy cable management and maintenance



Locking Kit
prevents accidental display pop-outs

Item No.	LVW13-46T
Screen Size	45" - 70"
Max. VESA	600x400
Weight Capacity	70kg/154lbs
Strength Tested	4 Times Approved
Profile	120-325mm (4.7"-12.8")
Tilt Range	+2°~-3°

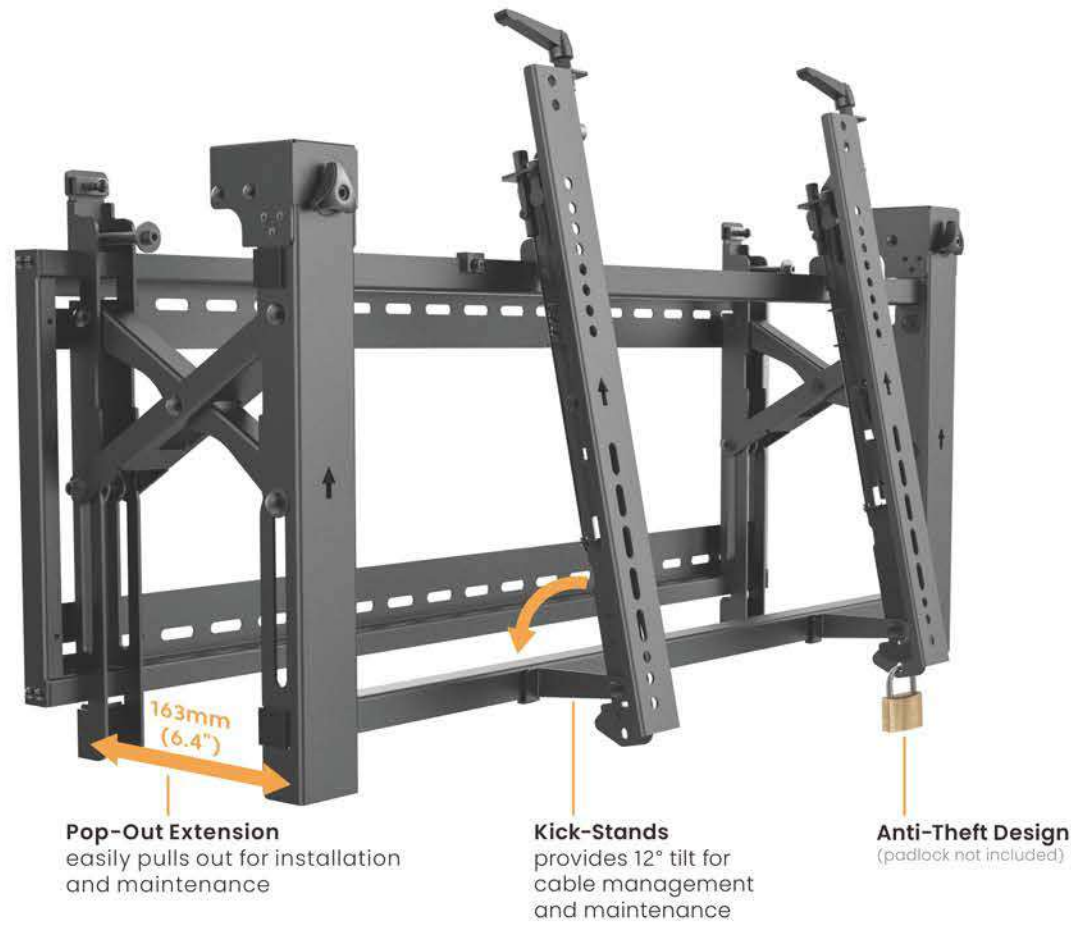

Lock and Release Knob offers quick release for mounting the display

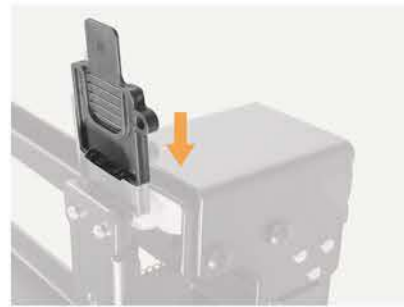

Pop-Out Lock prevents accidental display pop-outs

Tool-Free Display Alignment for seamless digital signage

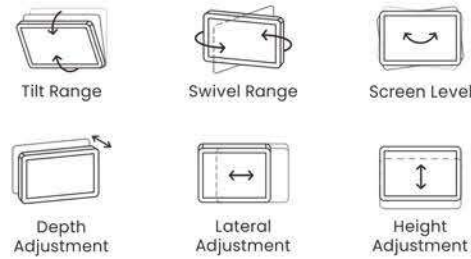

LVW03-46T Landscape

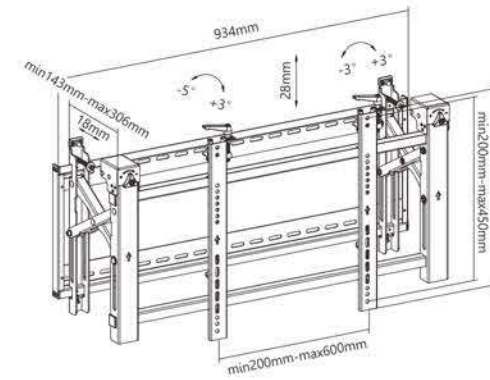

LVW03-48T Landscape

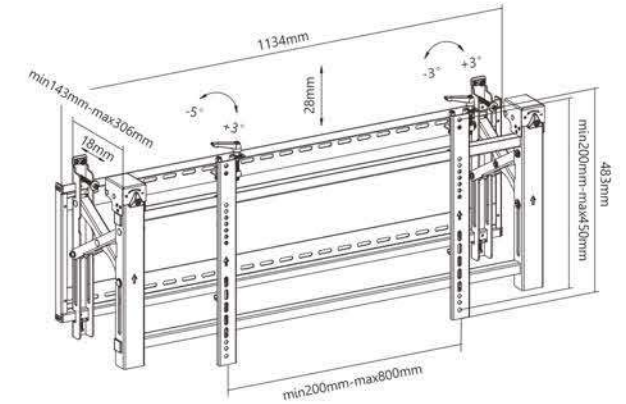

LVW03-64T Portrait

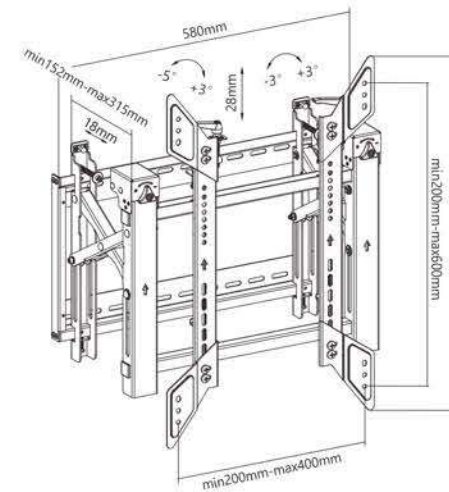

Item No.	LVW03-46T	LVW03-48T	LVW03-64T
Screen Size	45"-70"	54"-70"	45"-70"
Max. VESA	600x400	800x400	400x600
Weight Capacity	70kg/154lbs	70kg/154lbs	70kg/154lbs
Strength Tested	4 Times Approved	4 Times Approved	4 Times Approved
Profile	143-306mm (5.6"-12.0")	143-306mm (5.6"-12.0")	152-315mm (5.6"-12.4")
Tilt Range	+3°- -5°	+3°- -5°	+3°- -5°
Screen Level	+3°- -3°	+3°- -3°	+3°- -3°





Anti-Theft Design
(padlock not included)

Precise Display Alignment
for seamless digital signage



Tilt Range

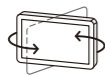

Swivel Range



Screen Level

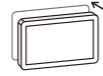

Depth Adjustment

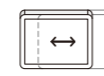

Lateral Adjustment

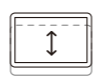

Height Adjustment



Pop-Out Lock
ensures safety by reducing the possibility of accidental pop-outs



Pop-Out Extension
provides quick access for installation and maintenance

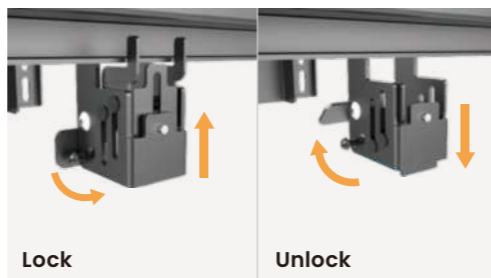

Quick-Release Latch
easily activates lock & unlock mode to secure displays

Customizable Components



LVW05-Arm



LVW06-Edge



LVW06-column50/75

LVW06-46T

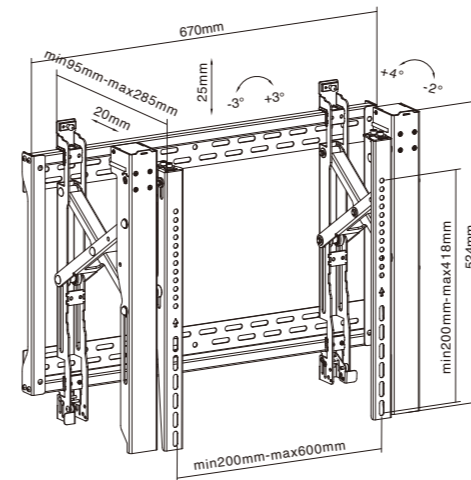

LVW06-48T

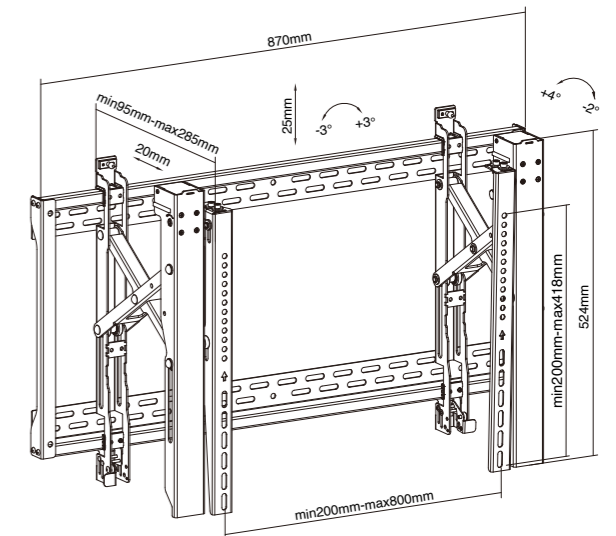

LVW06-400T

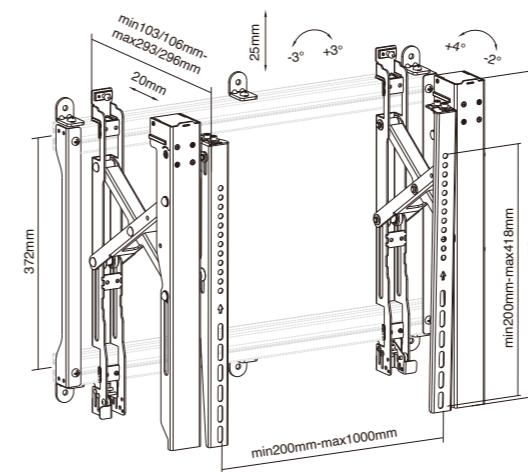

Item No.	LVW06-46T	LVW06-48T	LVW06-400T
Screen Size	45" - 70"	45" - 80"	Min 45"
Max. VESA	600x400	800x400	1000x400
Weight Capacity	70kg/154lbs	70kg/154lbs	70kg/154lbs
Strength Tested	4 Times Approved	4 Times Approved	4 Times Approved
Profile	95-285mm (3.7"-11.2")	95-285mm (3.7"-11.2")	103-293mm (4.1"-11.5") on 40x40mm T-slotted Pipe 106-296mm (4.2"-11.7") on 45x45mm T-slotted Pipe
Tilt Range	+4° ~ -2°	+4° ~ -2°	+4° ~ -2°
Screen Level	+3° ~ -3°	+3° ~ -3°	+3° ~ -3°

LVC03-FL Series

Aluminum Video Wall Ceiling Mounts

Video Wall Ceiling Mount is the perfect solution when creating impacting digital advertising display in no wall situation! Best of all, weight balancing function is included - fits most size of display!

ALUMINUM VIDEO WALL CEILING MOUNTS

LVC03-FL SERIES

 **Tool-Free Display Alignment**
for seamless digital signage



Tilt Range

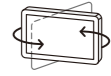

Swivel Range



Screen Level

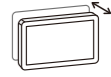

Depth Adjustment

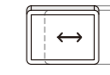

Lateral Adjustment

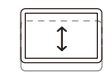

Height Adjustment



Keyhole Pattern Slot
for easy installation



Cable Management
keeps everything organized

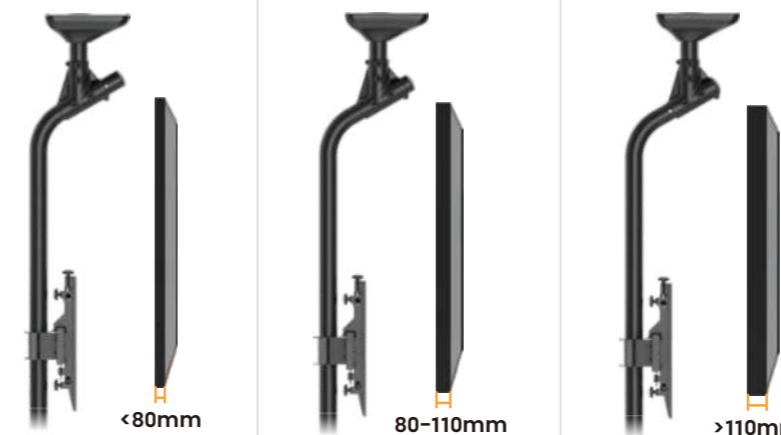

<80mm

80-110mm

>110mm

Weight Balancing System
ensures perfect vertical pole alignment,
no matter the size or thickness of TVs

ALUMINUM VIDEO WALL CEILING MOUNTS

LVC03-FL SERIES

LVC03-446FL-02 2x2

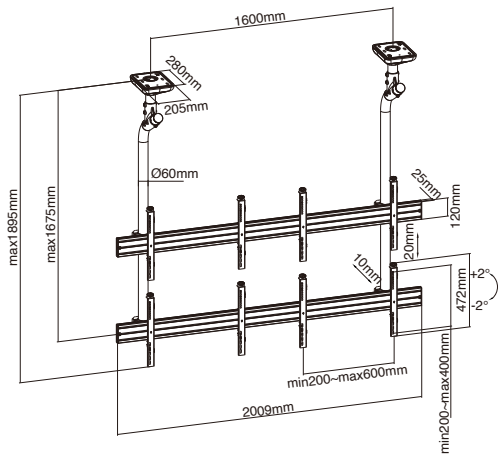

LVC03-946FL-03 3x3

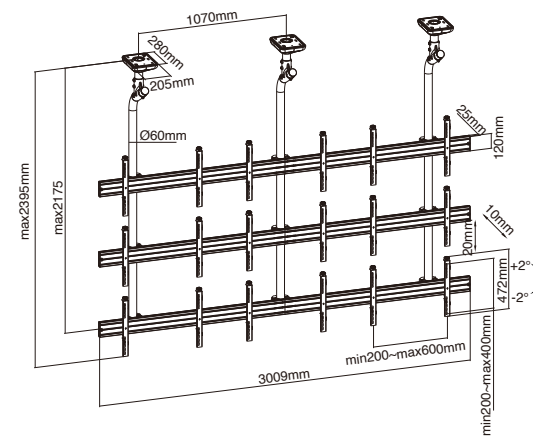

Item No.	LVC03-446FL-02	LVC03-946FL-03
Screen Size	45" -55"	45" -50"
Max. VESA	600x400	600x400
Screen Quantity	2x2	3x3
Weight Capacity (per screen)	50kg/110lbs	50kg/110lbs
Strength Tested	4 Times Approved	4 Times Approved
Profile	1895mm (74.6")	2395mm (94.3")
Tilt Range	+2° ~ -2°	+2° ~ -2°

LVS02 Series

Aluminum Video Wall Carts & Stands



The LVS02 Series offer a one-size-fits-all design. Available in a variety of configurations including **Freestanding, Mobile, or Permanent Fixed** – ideal for any digital signage or video wall installation. Also supporting curved multi-screen display.

Base Options

1 Mobile Base



2 Leveling Feet

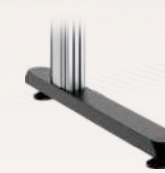

3 Pedestal

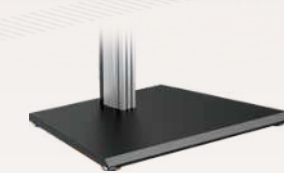

4 Bolt-Down Base

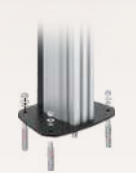

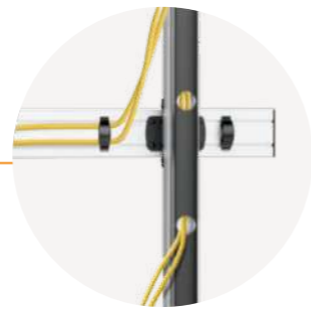
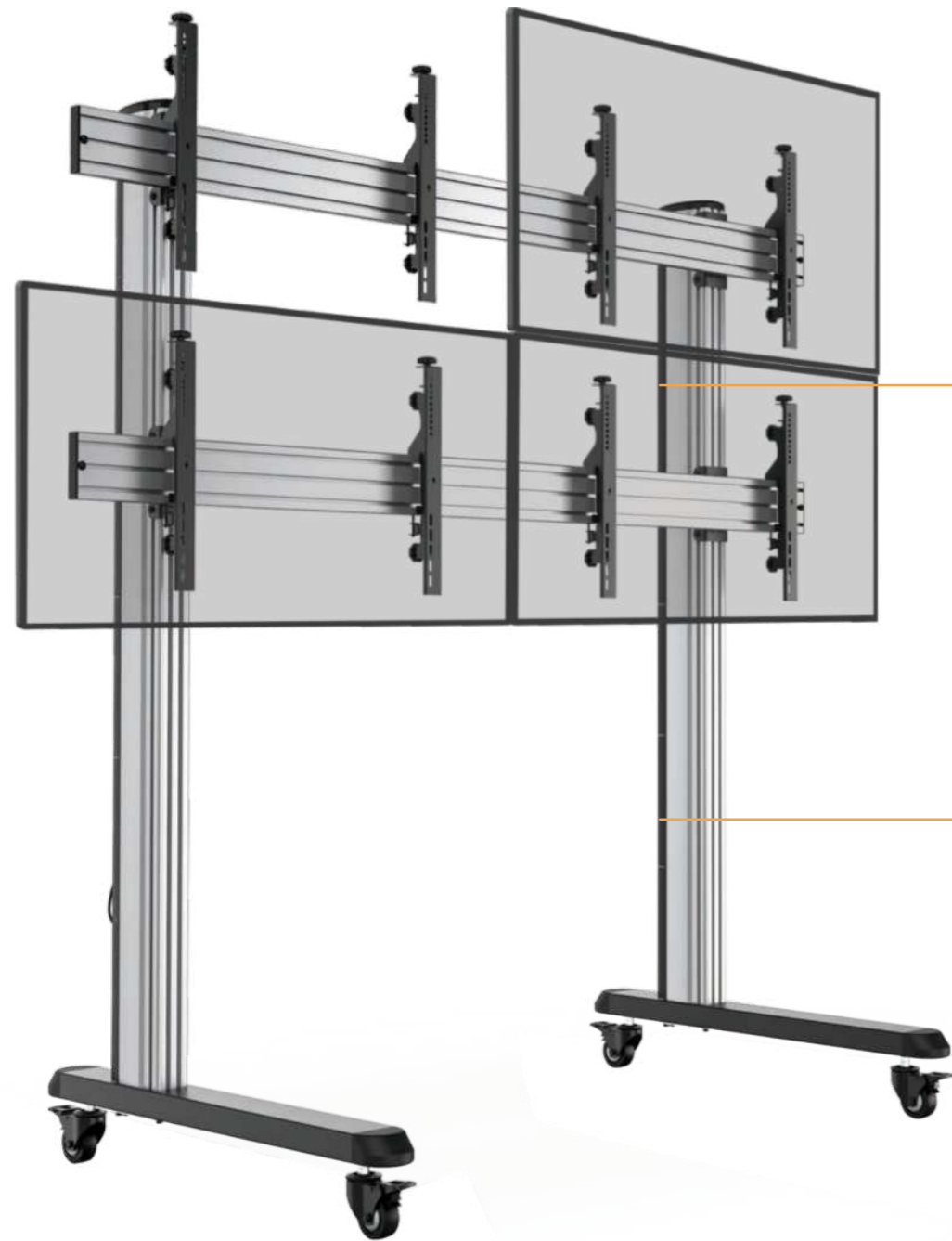

Cable Management
keeps everything organized



45mm (1.8") Slot Width
Additional Power Socket Slot
(PDU socket is not included)

Tool-Free Display Alignment
for seamless digital signage



Tilt Range

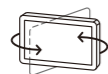

Swivel Range



Screen Level

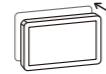

Depth Adjustment

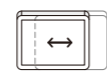

Lateral Adjustment



Height Adjustment

LVS02-246FP 1x2 / with Pedestal Base

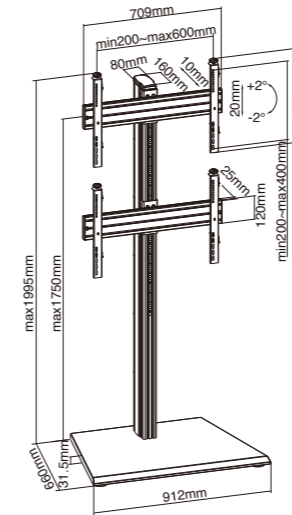

LVS02-246FW 1x2 / with Locking Casters

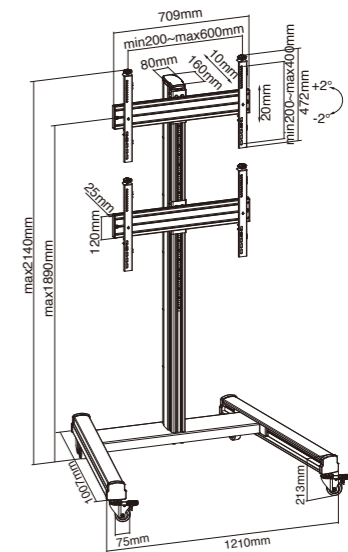

LVS02-446FB 2x2 / with Bolt-Down Base

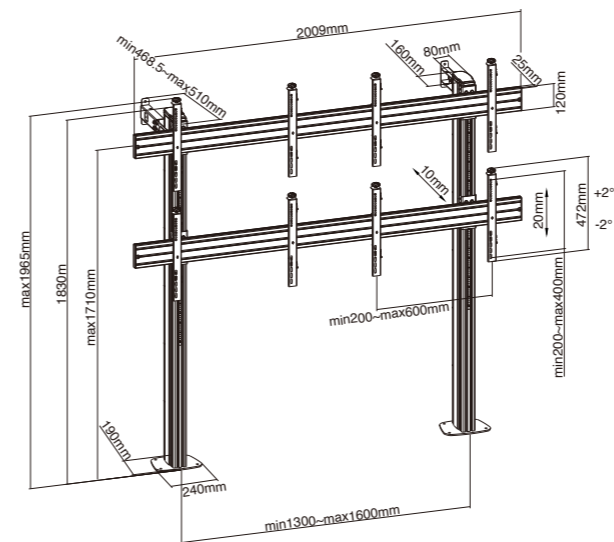

LVS02-946FB 3x3 / with Bolt-Down Base

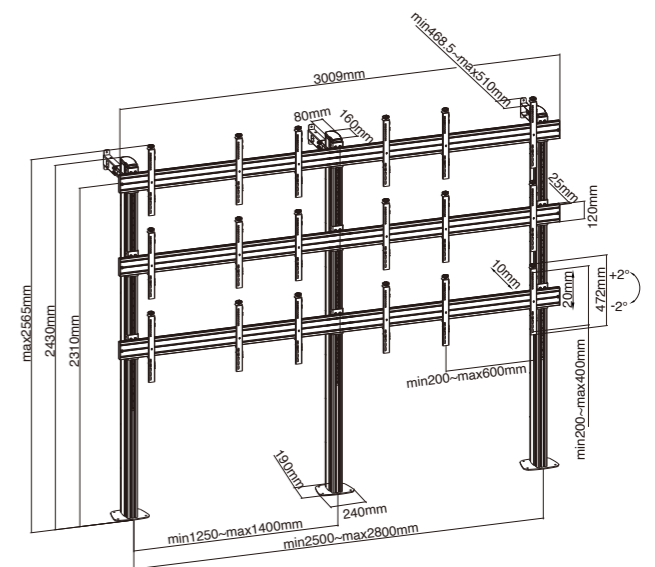

Item No.	LVS02-246FP	LVS02-246FW	LVS02-446FB	LVS02-946FB
Screen Size	40"-65"	40"-65"	45"-55"	45"-50"
Max. VESA	600x400	600x400	600x400	600x400
Screen Quantity	1x2	1x2	2x2	3x3
Weight Capacity (per screen)	50kg/110lbs	50kg/110lbs	50kg/110lbs	50kg/110lbs
Strength Tested	4 Times Approved	4 Times Approved	4 Times Approved	4 Times Approved
Tilt Range	+2° ~ -2°	+2° ~ -2°	+2° ~ -2°	+2° ~ -2°

ALUMINUM VIDEO WALL CARTS & STANDS

LVS02 SERIES

LVS02-446FW 2x2 / with Locking Casters

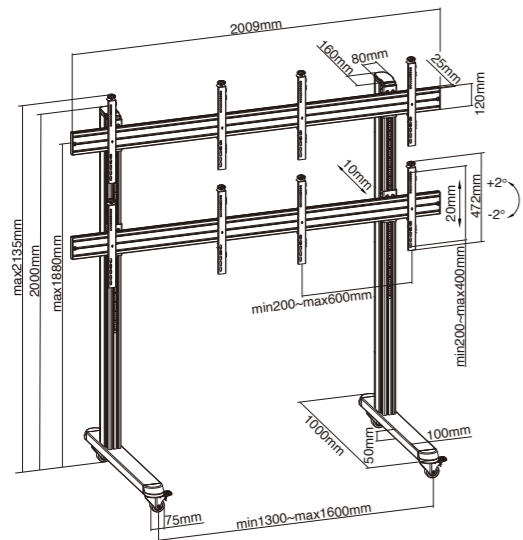

LVS02-946FW 3x3 / with Locking Casters

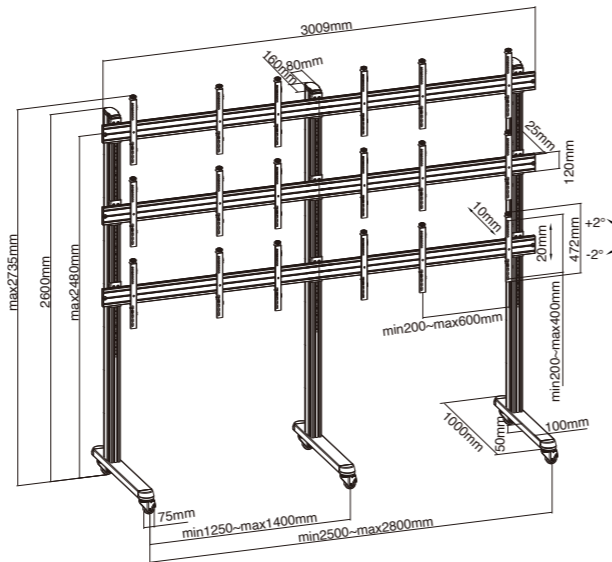

LVS02-446FF 2x2 / with Leveling Feet

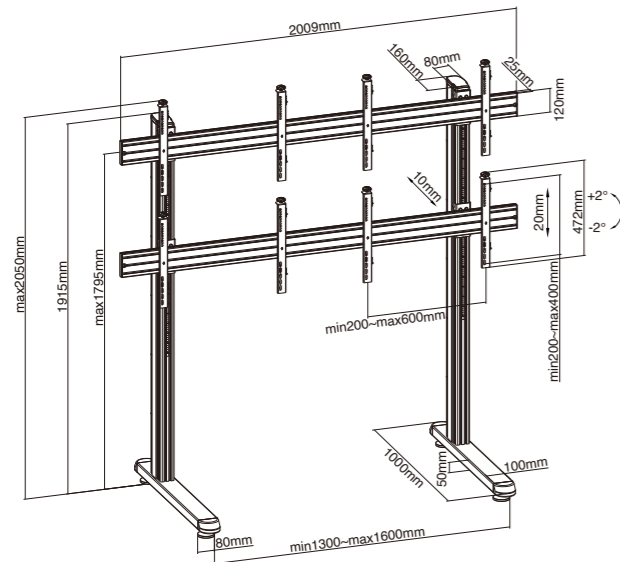

LVS02-946FF 3x3 / with Leveling Feet

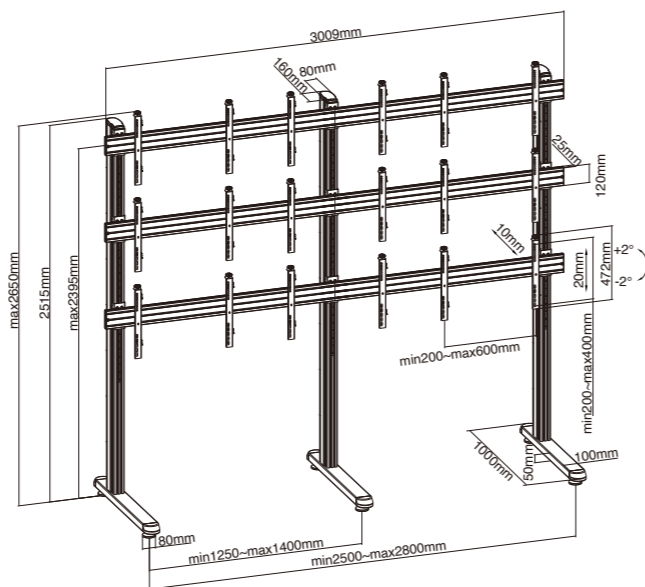

Item No.	LVS02-446FW	LVS02-946FW	LVS02-446FF	LVS02-946FF
Screen Size	45"-55"	45"-50"	45"-55"	45"-50"
Max. VESA	600x400	600x400	600x400	600x400
Screen Quantity	2x2	3x3	2x2	3x3
Weight Capacity (per screen)	50kg/110lbs	50kg/110lbs	50kg/110lbs	50kg/110lbs
Strength Tested	4 Times Approved	4 Times Approved	4 Times Approved	4 Times Approved
Tilt Range	+2° ~ -2°	+2° ~ -2°	+2° ~ -2°	+2° ~ -2°

LES01 Series

Direct View LED Video Wall Carts

Built for various direct view LED signage panels including Absen Acclaim, Unilumin Upanels, and Samsung IFH Series.



2 CONFIGURATIONS (for LES01-36SI)



6x3 Display

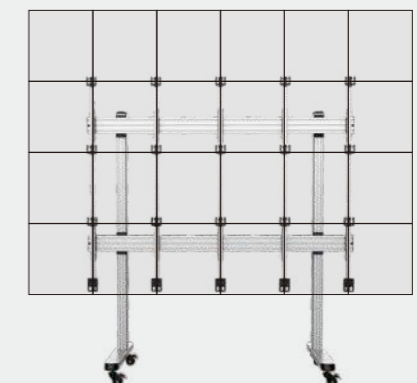

6x4 Display

DIRECT VIEW LED VIDEO WALL CARTS

LES01 SERIES



Lateral Shift
allows left and right adjustment along the rail



Hanging Mount
for faster assembly



Keyhole Slots
for easy installation and precise alignment



Cable Management
keeps everything organized



Anti-Theft Design
(padlock is not included)



Additional Power Socket Slot
(PDU socket is not included)

DIRECT VIEW LED VIDEO WALL CARTS

LES01 SERIES

LES01-36SI 6x3, 6x4 / For Samsung IFH Series

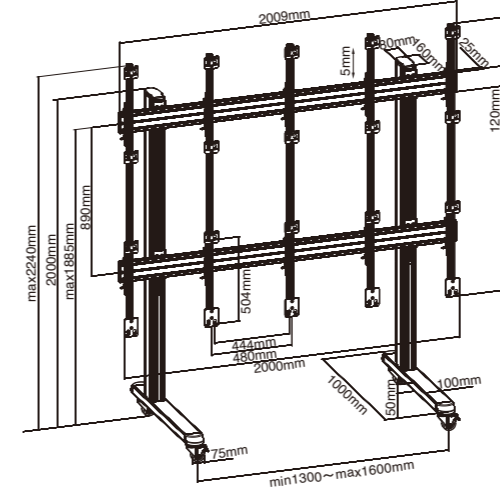

LES01-55AA 5x5 / For Absen Acclaim Series

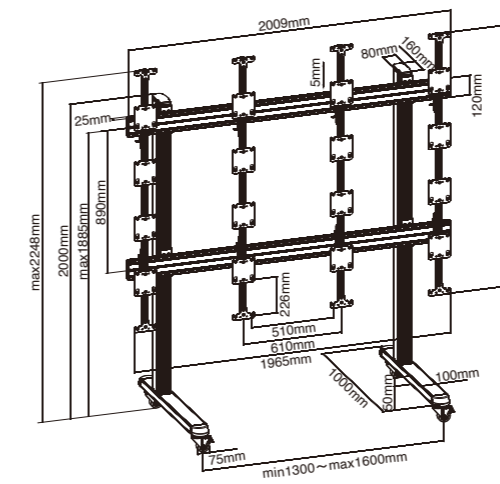

LES01-48SI 8x4 / For Samsung IFH Series

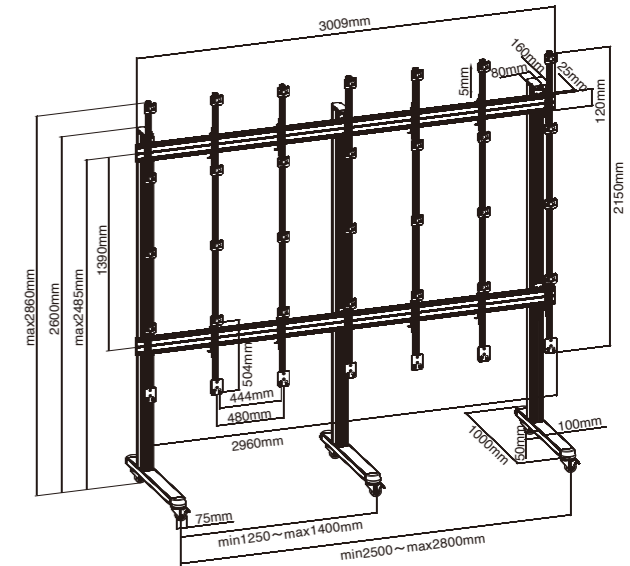

LES01-66AA 6x6 / For Absen Acclaim Series

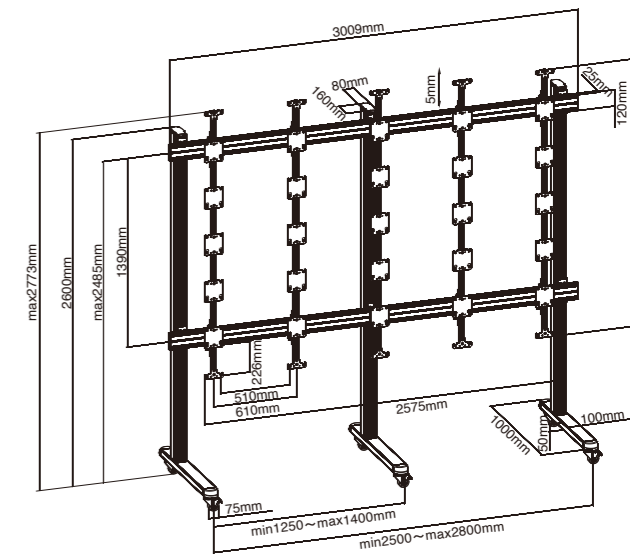

Item No.	LES01-36SI	LES01-48SI	LES01-55AA	LES01-66AA
Fit Screen	Samsung IFH Series	Samsung IFH Series	Absen Acclaim Series	Absen Acclaim Series
Screen Quantity	6x3, 6x4	8x4	5x5	6x6
Weight Capacity (per screen)	8kg/17.6lbs	8kg/17.6lbs	8.5kg/18.7lbs	8.5kg/18.7lbs
Strength Tested	3 Times Approved	3 Times Approved	3 Times Approved	3 Times Approved

DIRECT VIEW LED VIDEO WALL CARTS

LES01 SERIES

SLIDING AV STORAGE PANEL

APM-10-01

LES01-55UU 5x5 / For Unilumin Upanels Series

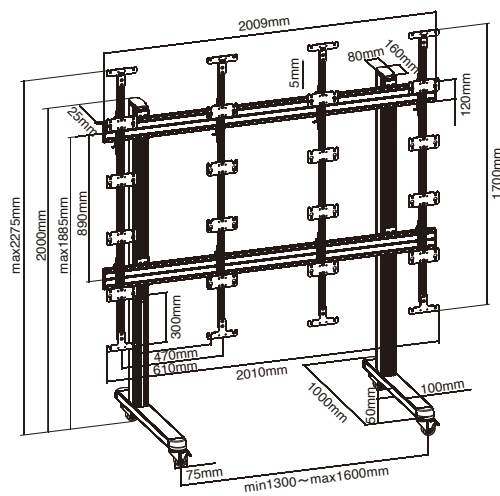

LES01-66UU 6x6 / For Unilumin Upanels Series

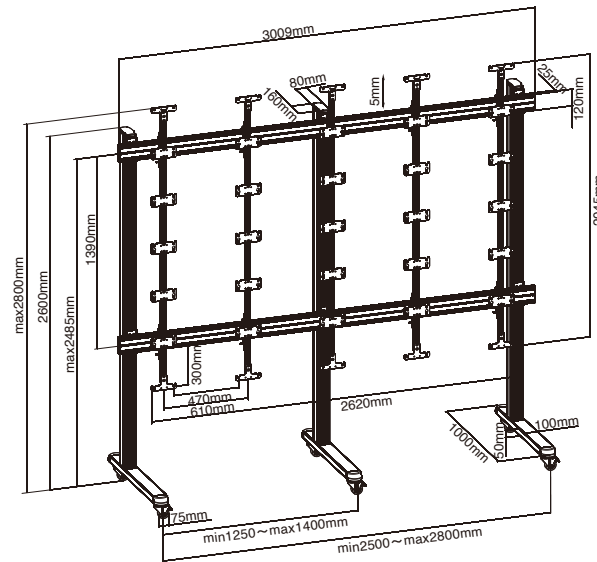

Item No.	LES01-55UU	LES01-66UU
Fit Screen	Unilumin Upanels Series	Unilumin Upanels Series
Screen Quantity	5x5	6x6
Weight Capacity (per screen)	8kg/17.6lbs	8kg/17.6lbs
Strength Tested	3 Times Approved	3 Times Approved

- ✓ Attach on either side of the display
- ✓ Two Mounting Options
 - Wall Mount
 - Rail Mount
 - (Compatible with LVS02 Series Videl Wall Carts & Stands)
- 300mm sliding range
- Easy Sliding Panel**
for quick access to all accessories
- Quick-Release Ties**
require no tool for the attachment of the AV devices and firmly hold the equipment
- Large Mounting Surface**
supports most AV accessories up to 10kg (22lb)

Detachable Panel
enables convenient mounting and removal of the accessories

Item No.	APM-10-01
Weight Capacity	10kg (22lbs)