

2023 | PROSUMER MOUNTING SOLUTIONS



Edition 10



www.xoxoo.co

# PROSUMER MOUNTING SOLUTIONS

2023



www.xoxoo.co

Tel: +65 9622 6641

Email: sales@xoxoo.co

Add: 202 Kallang Place #08-02 Singapore 339339



XoXoo



@shopxoxoo



@shopxoxoo



**PART D**  
MODULAR SOLUTIONS

**PART B**  
MENU BOARD MOUNTS

**PART A**  
VIDEO WALL MOUNTS

**PART E**  
PROJECTOR MOUNTS

**PART C**  
TV CARTS & STANDS

**PART F**  
TABLET & POS MOUNTS

# PRODUCTS

BY INDUSTRIES

## PUBLIC VENUE

- A03 Video Wall Mounts
- A09 Video Wall Ceiling Mounts
- A12 Video Wall Carts & Stands

## QSR & TICKET OFFICE

- B03 Menu Board Mounts

## CORPORATE

- C04 C31V Carts & Stands
- Interactive Display Mounts & Stands

## EDUCATION & TRAINING

- E03 Projector Mounts

## RETAIL & HOSPITALITY

- F04 F16 Tablet Mounts
- POS Mounts

# E | EDUCATION & TRAINING



1 PROJECTOR MOUNT E03

MORE RECOMMENDED PRODUCTS



PRB-21 Series

 E-mail:sales@xoxoo.co / www.xoxoo.co

 E-mail:sales@xoxoo.co / www.xoxoo.co



2 TV CART C31  
TTV13 Series

PRB-23 Series

# ADJUSTABLE MINI PROJECTOR FLOOR STANDS



## ADJUSTABLE MINI PROJECTOR FLOOR STANDS

PRB-23 SERIES



**Universal Mount with 360° Rotation Head** provides flexible angle adjustment and easy image alignment

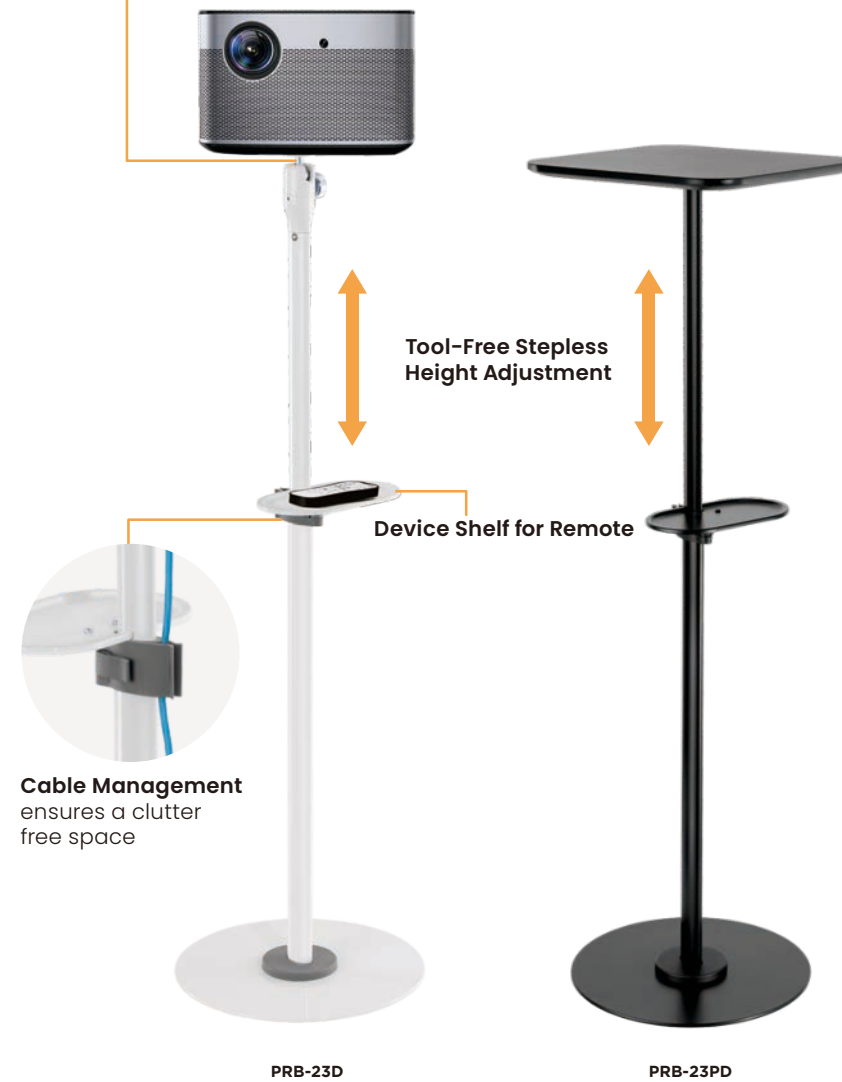

**Cable Management** ensures a clutter free space

360°-SWIVEL HEAD

**PRB-23**

**PRB-23D** with device shelf

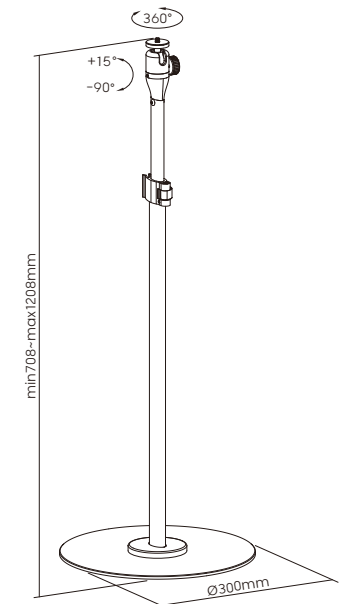

FIXED TRAY

**PRB-23P**

**PRB-23PD** with device shelf

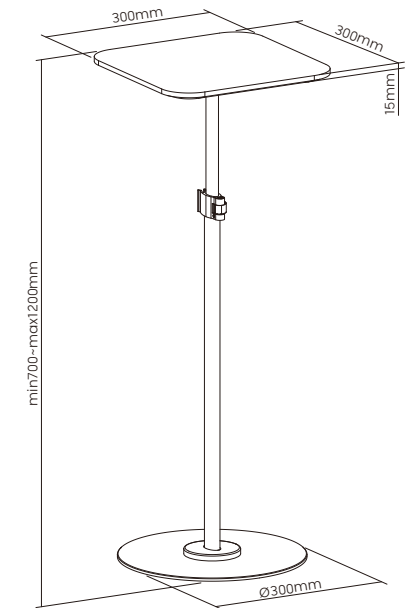

Colors:

Item No.	PRB-23	PRB-23D	PRB-23P	PRB-23PD
Weight Capacity (Device Shelf)	/	2kg/4.4lbs	/	2kg/4.4lbs
Weight Capacity (Projector Mount)	6kg/13.2lbs	6kg/13.2lbs	6kg/13.2lbs	6kg/13.2lbs
Tilt Range	+15°~ -90°	+15°~ -90°	/	/
Height Range	708~1208mm(27.9"~47.6")	708~1208mm(27.9"~47.6")	700~1200mm(27.6"~47.2")	700~1200mm(27.6"~47.2")
Material	Steel,Aluminum,Plastic	Steel,Aluminum,Plastic	Steel,Plastic	Steel,Plastic

# SHORT THROW PROJECTOR WALL MOUNTS

PRB-21 SERIES

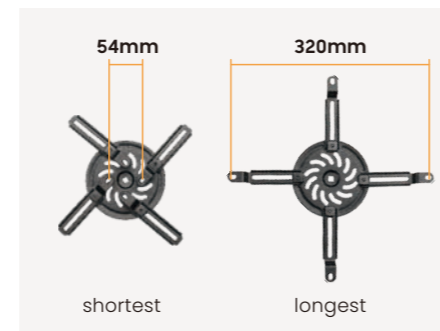
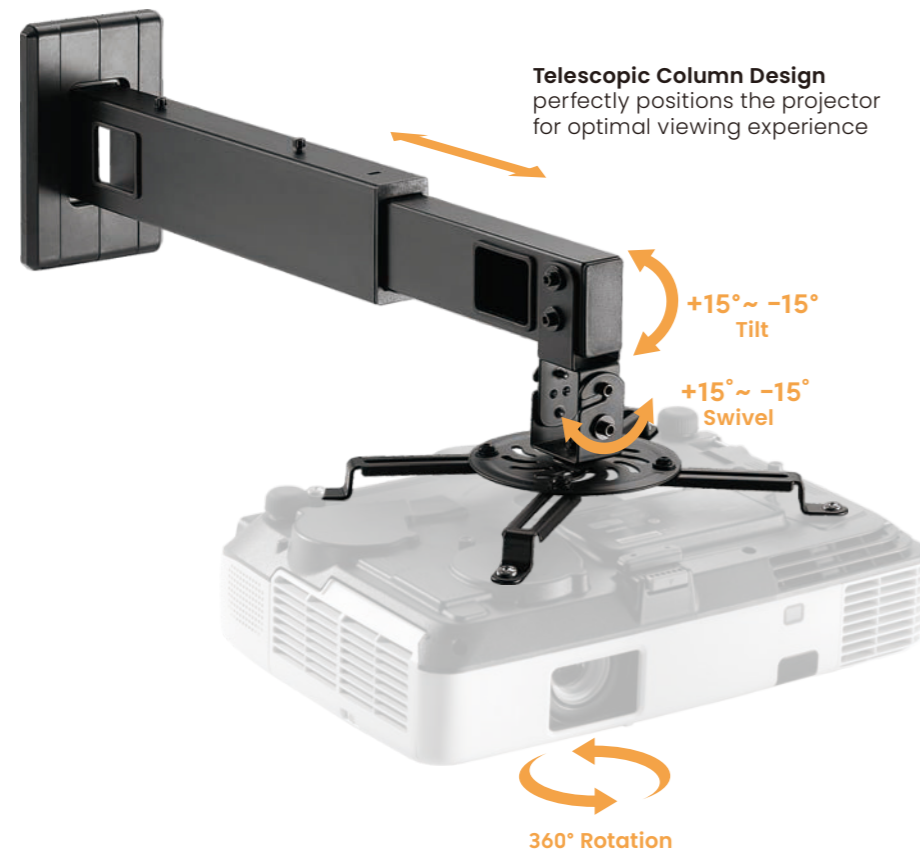

**Adjustable Support Arms** fit most short throw projectors



**Integrated Cable Management** keeps a neat and clean appearance

PRB-21M

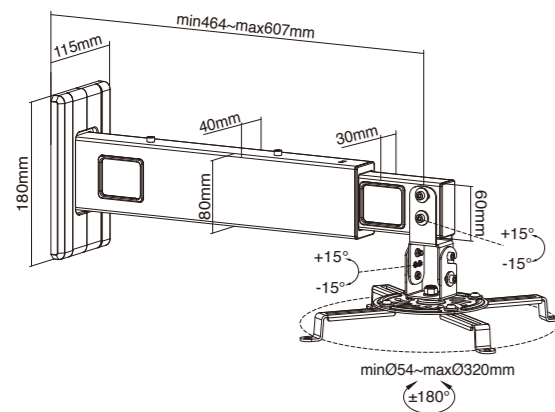

PRB-21L

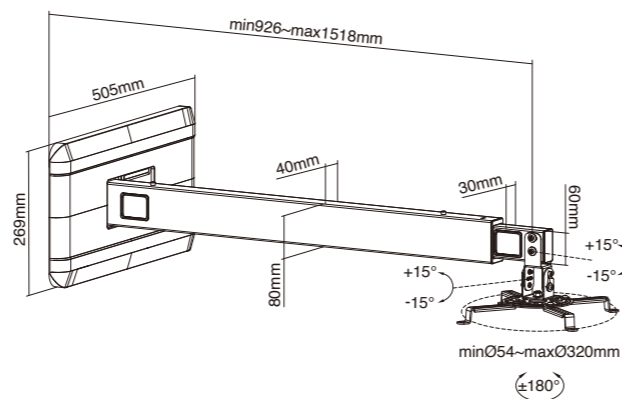

Item No.	PRB-21M	PRB-21L
Mounting Range	54~320mm (2.1"-12.6")	54~320mm (2.1"-12.6")
Weight Capacity	15kg/33lbs	15kg/33lbs
Extension Range	464~607mm (18.3"-23.9")	926~1518mm (36.5"-59.8")
Tilt Range	+15° ~ -15°	+15° ~ -15°
Swivel Range	+15° ~ -15°	+15° ~ -15°
Rotation	+180° ~ -180°	+180° ~ -180°
Material	Steel, Plastic	Steel, Plastic

# HEAVY-DUTY PROJECTOR CEILING MOUNTS

PRB-20 SERIES



**Detachable Mounting Plate** for quick and easy installations



**Versatile Application** available in flat or pitched ceiling models

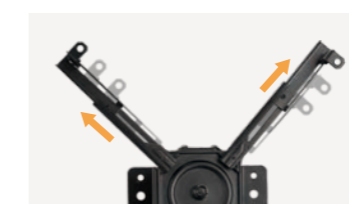

**Adjustable Mounting Holes** fit most projectors in the market

Colors:

For Flat or Pitched Ceiling

PRB-20-01S

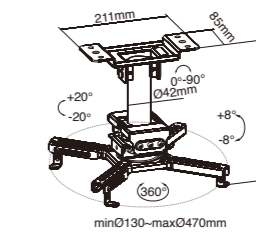

PRB-20-01M

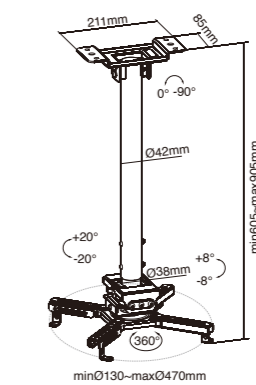

PRB-20-01L

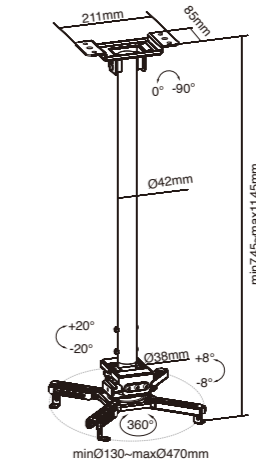

For Flat Ceiling

PRB-20-02S

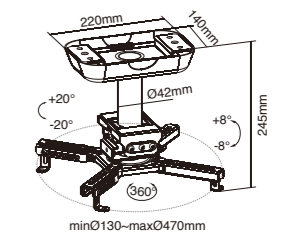

PRB-20-02M

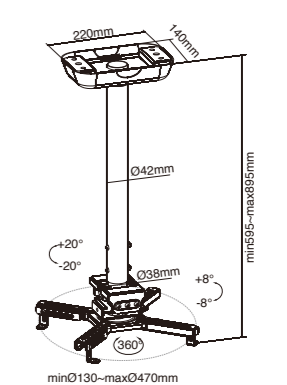

PRB-20-02L

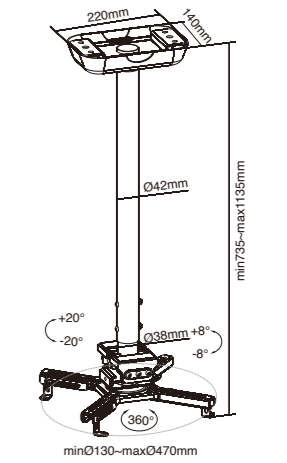

Item No.	PRB-20-01S	PRB-20-01M	PRB-20-01L	PRB-20-02S	PRB-20-02M	PRB-20-02L
Mounting Range	130~470mm (5.1"-18.5")	130~470mm (5.1"-18.5")	130~470mm (5.1"-18.5")	130~470mm (5.1"-18.5")	130~470mm (5.1"-18.5")	130~470mm (5.1"-18.5")
Weight Capacity	45kg/99lbs	35kg/77lbs	35kg/77lbs	45kg/99lbs	35kg/77lbs	35kg/77lbs
Strength Tested	4 Times Approved	4 Times Approved	4 Times Approved	4 Times Approved	4 Times Approved	4 Times Approved
Profile	255mm (10")	605~905mm (23.8"-35.6")	745~1145mm (29.3"-45.1")	245mm (9.6")	595~895mm (23.4"-35.2")	735~1135mm (28.9"-44.7")
Tilt Range	+20° ~ -20°	+20° ~ -20°	+20° ~ -20°	+20° ~ -20°	+20° ~ -20°	+20° ~ -20°
Swivel Range	+8° ~ -8°	+8° ~ -8°	+8° ~ -8°	+8° ~ -8°	+8° ~ -8°	+8° ~ -8°
Rotation	360°	360°	360°	360°	360°	360°

# COMPACT PROJECTOR CEILING MOUNT

EPB-2



**Hook-On Design**  
for quick installation

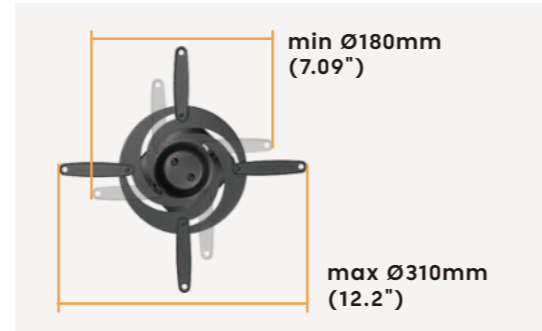

**Adapter Arm Extension Range**  
supports various projector sizes



**Cable Management**  
keeps everything organized

EPB-2

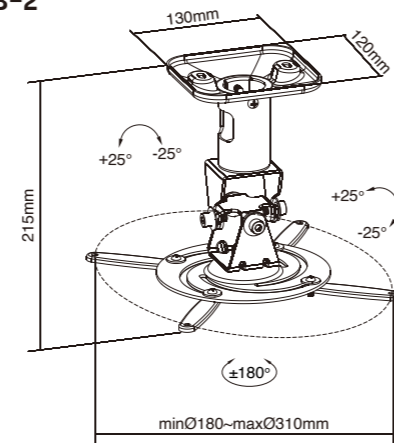

Colors:

Item No.	EPB-2
Mounting Range	180-310mm (7.1"-12.2")
Weight Capacity	15kg /33lbs
Profile	215mm (8.5")
Tilt Range	+25°~-25°
Swivel Range	+25°~-25°
Rotation	+180°~-180°

# STEEL PROJECTOR RISER

PRS-01



**Multi-Purpose**  
also for supporting laptops, speakers and more



**Ball Joint Design**  
for perfect viewing angles

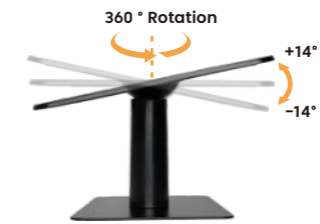

**Anti-Slip Pads**  
protect the desktop from scratches

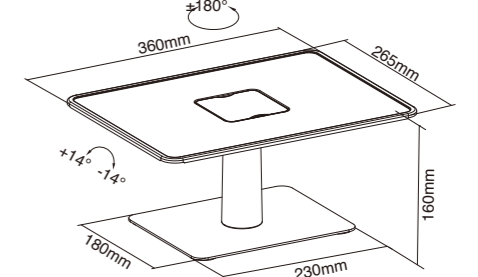

Item No.	PRS-01
Weight Capacity	10kg /22lbs
Tilt Range	+14°~-14°
Rotation	+180°~-180°
Material	Steel, Plastic

# ALUMINUM TRIPOD PROJECTOR STAND

PRB-22P

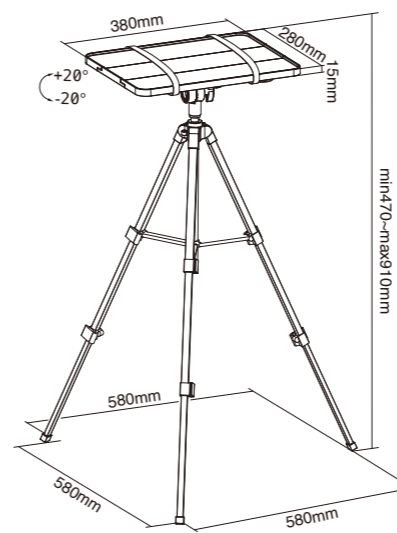

Item No.	PRB-22P
Weight Capacity	6kg/13.2lbs
Tilt Range	+20°~-20°
Material	Aluminum, Steel, Plastic



**Safety Strap**

-20°~+20°

**Anti-Skid Feet**



**Removable Tray**  
space-saving when not in use



**Retractable Folding Tripod Legs**  
ideal for transport and storage



**Nylon Bag**  
easy for carrying

# INDEX

For Item No. & Product Series Search

## A

Aluminum Menu Board Mounts	
Aluminum Menu Board Ceiling Mount	B03-B06
Aluminum Menu Board Wall Mount	B04-B06
Aluminum TV Carts	
Elemental Aluminum TV Cart	C24
Heavy-Duty Studio Aluminum TV Cart	C07
Compact Aluminum TV Cart	C26
Height-Adjustable Aluminum TV Carts with Crank Handle	C13-C14 C11-
Interactive Counterbalance Aluminum TV Carts	C12 C04-
Motorized Large TV Carts & Stands	C06 C17-
Telescopic Height-Adjustable Aluminum TV Carts Ultra-	C19 C15-
Modern Aluminum TV Carts	C16
Aluminum Video Wall Mounts	
Aluminum Video Wall Carts & Stands	A12-A15
Aluminum Video Wall Ceiling Mounts	A09-A11
Anti-Theft Tablet Enclosures & Kiosks	
iPad Enclosures & Kiosks	F09-F11 F07-
iPad/Samsung Galaxy Tablet Enclosures & Kiosks	F08/F12-F15
Universal Tablet Kiosks	F04-F06
APM-10-01	A20

## C

Component-Based Configurations	
Additional Accessories	D15
Ceiling-Mounted Solutions	D05-D08
Mobile & Fixed Solutions	D11-D14
Wall-Mounted Solutions	D09-D10

## D

Direct View LED Video Wall Carts	A16-A19
Dual Screen Cart for Interactive Displays	C36

## E

Economy TV Carts & Stands	C28-C30
EPB-2 Compact Projector Ceiling Mount	E07

## F

Floor Standing Projector Mount FS11-	E03-E04
46T Compact Aluminum TV Cart	C26
FS22 Series Compact Steel TV Carts & Stand	C27
FS23-44TW Economy Steel TV Cart	C28
FS44 Series Elemental Aluminum TV Cart	C24-C25

## H

HAW400 Series Height-Adjustable Wall Mounts for Interactive Display	C37-C38
Heavy-Duty Carts & Stands	
Heavy-Duty Carts & Stand for Interactive Displays	C34-C35
Heavy-Duty TV Carts & Stands	C09-C10

## I

Interactive Display Carts & Stands	
Dual Screen Cart for Interactive Displays	C36
Heavy-Duty Carts & Stand for Interactive Displays	C34-C35
Mobile Stand for Interactive Displays	C31-C32
Interactive Display Wall Mounts	
Height-Adjustable Wall Mounts for Interactive Displays	C37-C38

## L

LED Display Video Wall Mount	A04-A15
LCD Display Video Wall Mount	A16-A19
LES01 Series Direct View LED Video Wall Carts LVC03	A16-A19
Series Aluminum Menu Board Ceiling Mounts LVC03-	B06
FL Series Aluminum Video Wall Ceiling Mounts LVS02	A09-A11
Series Aluminum Video Wall Carts & Stands LVW03	A12-A15
Series Premium Video Wall Mounts	A05-A06
LVW06 Series Classic Video Wall Mounts	A07-A08
LVW10 Series Aluminum Menu Board Wall Mounts	B05 A03-
LVW13-46T Optimal Full Service Video Wall Mount	A04

## M

Menu Board Mounts	
Menu Board Ceiling Mounts	B06
Menu Board Wall Mounts	B05
Modular Components	
<b>Aluminum Columns</b>	D14
LVS02-C18 1800mm LVS02-C24 2400mm	
<b>Aluminum Rails</b>	
LVS02-R150 1500mm LVS02-	D10
R200 2000mm LVS02-R70	
700mm	
LVW06-Column50 495mm	
LVW06-Column75 745mm	
<b>Bases</b>	
LVS02-B01 Floor Base with Leveling Feet	D13-D14
LVS02-B02 Pedestal Base	
LVS02-B03 Permanent Fixed Base LVS02-	
B04 H Style Base with Casters	
LVS02-B05 H Style Base with Leveling Feet	
LVS02-CASTER Mobile Casters	
<b>Brackets</b>	
LVS02-40M Micro-Adjustment	D10
LVS02-40T Tilt	
LVS02-80F Fixed	
LVW06-Arm Pop-Out	

### Other Components

LVC03-W01 Ceiling Plate LVC03-	D08
W02 Rail-to-Pole Collar	D08
LVS02-CM01 Adjustable Camera Shelf	D15
LVS02-J01 Rail-to-Column Connector	D14
LVS02-J02 Angle Adjustment Rail Connector	D16
LVS02-W01 Wall Plate	D09
APM-10-01 Sliding AV Storage Panel	D16
<b>Poles</b>	D07

LVC03-C100-2 1000mm LVC03-C150-2 1500mm	
LVC03-C175-1 1750mm (with Weight-Balancing)	
LVC03-C225-1 2250mm (with Weight-Balancing)	

<b>Motorized Large TV Carts &amp; Stand</b>	C04-C06
---	---------

## P

PAD12 Series Anti-theft Tablet Kiosks	F15
PAD26 Series Anti-theft Tablet Kiosks/Enclosures	F12-F14
PAD32 Series Anti-theft Tablet Kiosks/Enclosures	F09-F11
PAD33 Series Universal Anti-Theft Tablet Kiosks	F04-F06
PAD34 Series Simplicity Anti-theft Tablet Kiosks	F07-F08
PMM-02 POS Mounting Solution	F16-F18
PMM-03 Tablet & Print Stands for mPOS	F20

PRB-20 Series Heavy-Duty Projector Ceiling Mounts	E06
PRB-21 Series Short Throw Projector Wall Mounts	E05
PRB-22P Aluminum Tripod Projector Stand	E08
PRB-23 Series Adjustable Mini Projector Floor Stands	E03-E04
PTS-05 Universal POS Terminal Stand	F19
Projector Mounts & Stands	
Adjustable Mini Projector Floor Stands	E03-E04
Compact Projector Ceiling Mount	E07
Heavy-Duty Projector Ceiling Mounts	E06
Projector Riser/Stand	E08
Short Throw Projector Wall Mounts	E05
PRS-01 Steel Projector Riser	E08

## S

Steel TV Carts & Stands	
Compact Steel TV Carts	C27
Economy Steel TV Carts	C28
Streamlined Steel TV Stands & Carts	C09-C10
Telescopic Height-Adjustable Steel TV Carts	C17-C23

## T

T1028 Series Economy Steel TV Carts	C30
T1040 Series Economy Steel TV Carts	C29
<b>TT04 Series Telescopic Height-Adjustable Aluminum TV Carts with Crank Handle</b>	C13-C14
TT06 Series Telescopic Height-Adjustable Steel TV Carts TT07	C20-C23
Series Telescopic Height-Adjustable Aluminum TV Carts TT08	C17-C19
Series Streamlined Steel TV Carts & Stands	C09-C10
TT09 Series Heavy-Duty Carts & Stand for Interactive Displays	C34-C35
TT12 Series Ultra-Modern Aluminum TV Carts	C15-C16
TTD09-46FW Dual Screen Cart for Interactive Displays TTL14-	C36
68 Series Motorized Large TV Carts & Stand	C04-C06
TTV05 Series Interactive Counterbalance Aluminum TV Carts	C11-C12
TTV11-46TW Mobile Stand for Interactive Displays TTV13-46TW	C33 C31-
Stylish Mobile Stand for Interactive Displays	C32 C07
TT15-68FW Heavy-Duty Studio Aluminum TV Cart	
TV Carts & Stands	
Compact Aluminum/Steel TV Carts	C26-C27
Economy Steel TV Carts	C28 C11-
Interactive Counterbalance Aluminum TV Carts	C12 C04-
Motorized Large TV Carts & Stand	C09-C10
Streamlined Steel TV Stands & Carts	C17-C19
Telescopic Height-Adjustable Aluminum TV Carts	C13-C14
Telescopic Height-Adjustable Aluminum	C20-C23
Telescopic Height-Adjustable Steel TV Carts	C15-C16
Ultra-Modern Aluminum TV Carts	

## V

Video Wall Carts & Stands	
Aluminum Video Wall Carts & Stands	A12-A15
Direct View LED Video Wall Carts	A16-A19
Video Wall Ceiling Mounts	
<b>Video Wall Mounts</b>	A09-A11
Classic Video Wall Mounts	A07-A08
Optimal Video Wall Mount	A03-A04
Premium Video Wall Mounts	A05-A06

### Note:

Unless otherwise indicated, products and/or accessories shown in conjunction with XoXo® products displayed in this publication are not included. All company, product and service names used in this publication are for identification purposes only. Logos or Trademarks shown belong to their respected owners. ®

©2023 All Rights Reserved.

All images and specifications are for reference only, actual product may vary.