

2023 | PROSUMER MOUNTING SOLUTIONS



Edition 10



www.xoxoo.co

PROSUMER MOUNTING SOLUTIONS

2023



www.xoxoo.co

Tel: +65 9622 6641

Email: sales@xoxoo.co

Add: 202 Kallang Place #08-02 Singapore 339339



XoXoo



@shopxoxoo



@shopxoxoo



PART D
MODULAR SOLUTIONS

PART B
MENU BOARD MOUNTS

PART A
VIDEO WALL MOUNTS

PART E
PROJECTOR MOUNTS

PART C
TV CARTS & STANDS

PART F
TABLET & POS MOUNTS

PRODUCTS

BY INDUSTRIES

PUBLIC VENUE

- A03 Video Wall Mounts
- A09 Video Wall Ceiling Mounts
- A12 Video Wall Carts & Stands

QSR & TICKET OFFICE

- B03 Menu Board Mounts

CORPORATE

- C04 C31V Carts & Stands
- Interactive Display Mounts & Stands

EDUCATION & TRAINING

- E03 Projector Mounts

RETAIL & HOSPITALITY

- F04 F16 Tablet Mounts
- POS Mounts

COMPONENT-BASED Configurations



Financial & Surveillance



Transportation

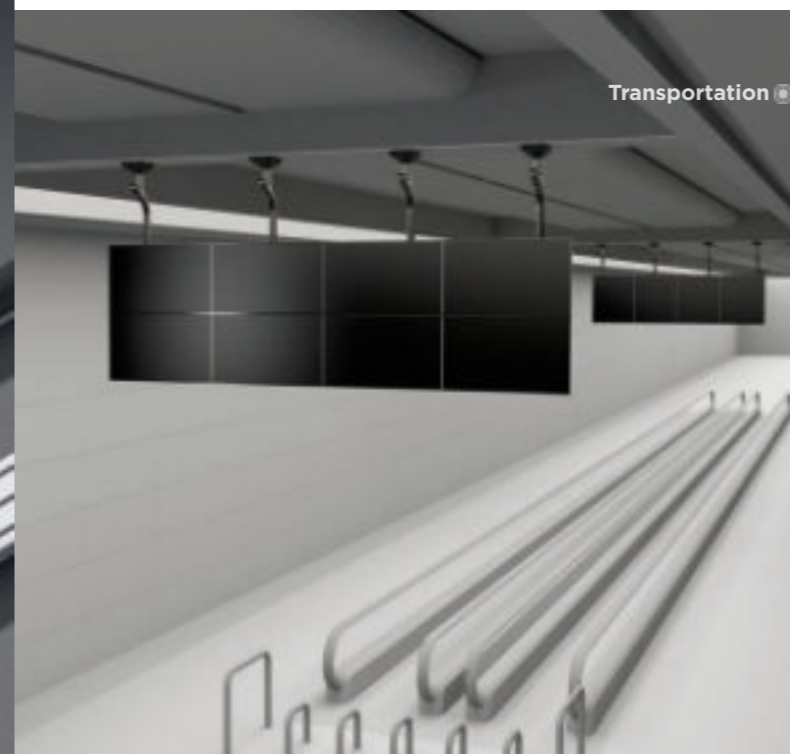

MODULAR SOLUTIONS FOR DIGITAL SIGNAGE DISPLAYS

Modular solutions save both time and money by providing the ultimate versatility for designers and installers. XoXoo offers components that can be configured as **Ceiling Mounts, Fixed Stands or Wall Mounted Displays** - creating endless possibilities for most any application - including retail, broadcast, education, transportation and more!

Conference

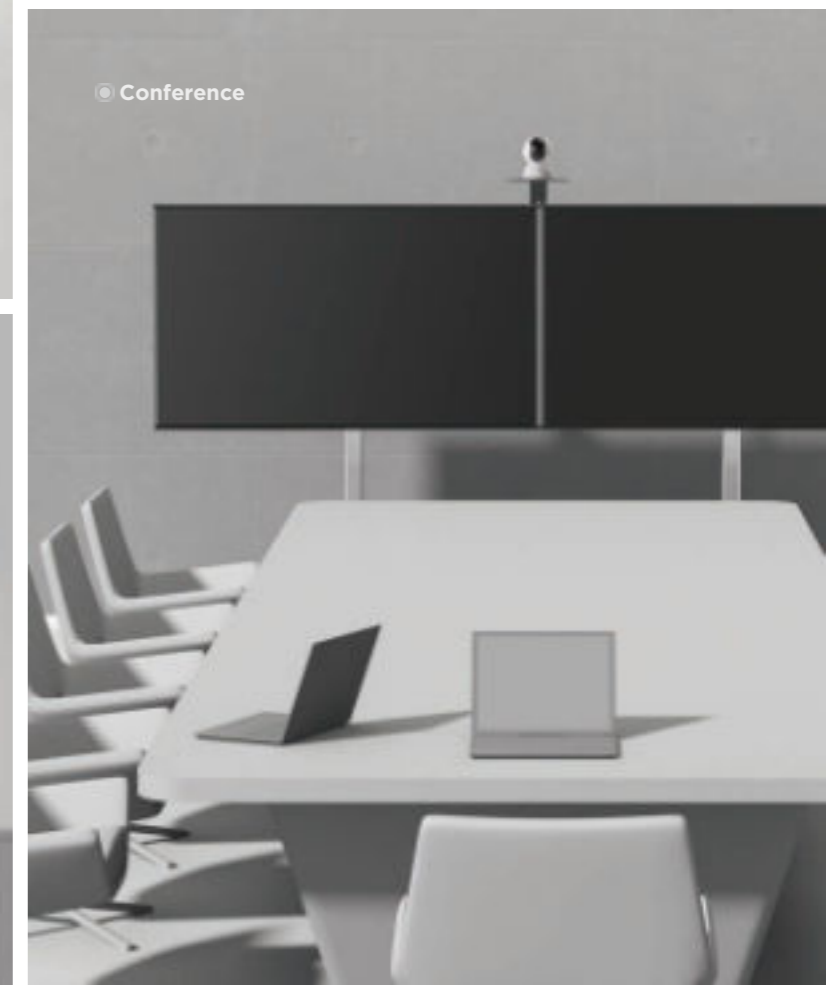

Hospitality

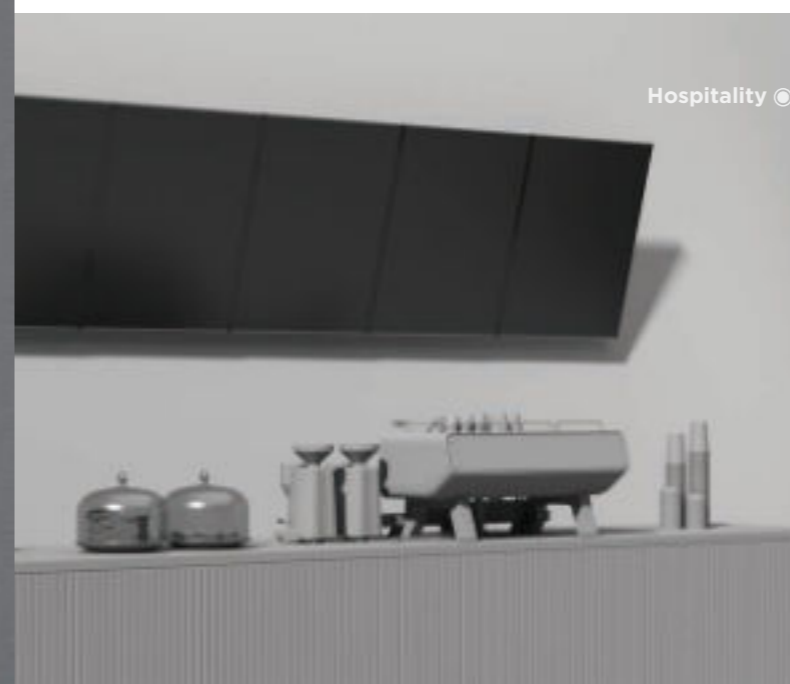

XOXOO HELPS CLIENTS TACKLE TOUGH DISPLAY NEEDS

It's difficult to find the right product that fits all the needs when creating displays for unique environments. That's the inspiration behind XoXoo's modular solutions.

Based on research and a full understanding of the AV industry, we offer mounts with **practical features, quality construction and at affordable prices.**

FEATURES

Specific & Professional

LUMI provides the exact mounting components for nearly every application, from single, dual or an entire wall of video displays, we offer the components that match the need.



Standard Straight Poles

Creating Tiled Display Patterns using Standard Straight Poles (which are popular in the market) may lead to safety problems as the displays will tend to tilt as time goes by causing display



Poles with Weight-Balancing

When using Poles with a Weight-Balancing feature, long term



Standard Straight Poles

Standard Straight Poles are ideal for single row of displays.

The Weight-Balancing System



Modular Design

creates endless configurations for most any environment



Easy Installation

The reinforced ceiling plate offers a solid foundation for the pole and contains keyhole slots that provide quick slide-on and screw-in installation.

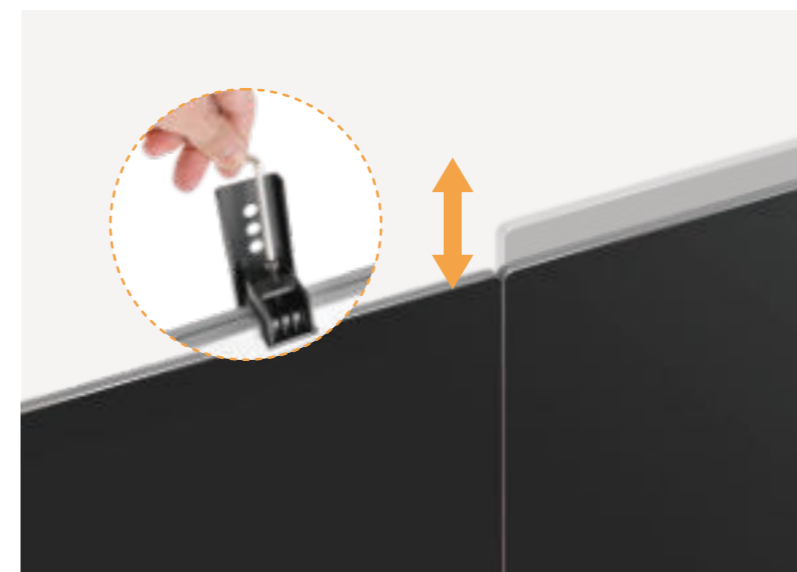

Precise Leveling

each bracket offers micro-height adjustments to ensure displays are perfectly aligned resulting in a nearly seamless appearance.



Basic Installation Overview for Ceiling Mounts

The following information provides an overview of the necessary components required to install a ceiling mount.

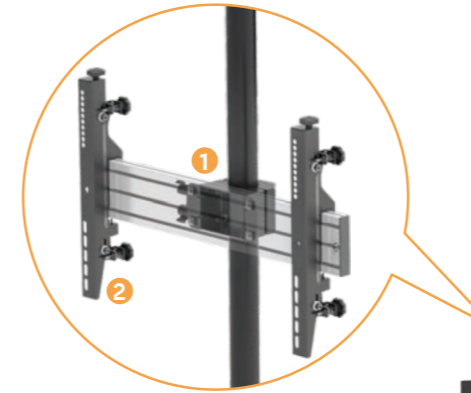

- 1 Collar**
Joins rails to the poles
- 2 Brackets**
Choose from Fixed, Tilt and Micro-Adjustment Brackets
For More Details - See Page D10
- 3 Ceiling Plate**
- 4 Poles**
Choose from Weight-Balanced or Standard Pole
For More Details - See Page D07
- 5 Aluminum Rails**



Four Times
Strength Tested

COMPONENT-BASED CONFIGURATIONS

CEILING-MOUNTED SOLUTIONS

POLES

LVC03-C100-2
Standard Pole
1000mm

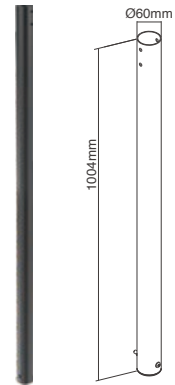

LVC03-C150-2
Standard Pole
1500mm

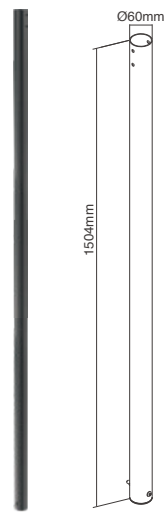

LVC03-C175-1
Pole with Weight-Balancing
1750mm

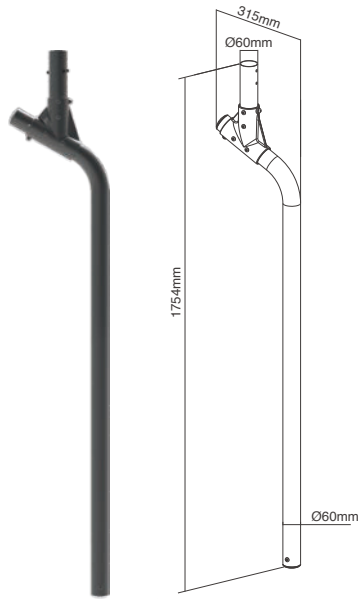

LVC03-C225-1
Pole with Weight-Balancing
2250mm

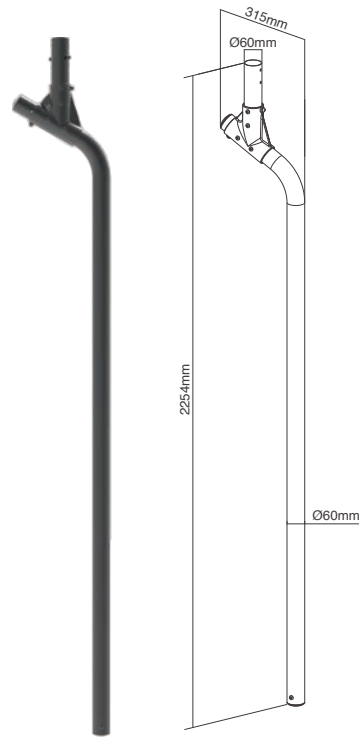

TYPICAL DISPLAY CONFIGURATIONS



SINGLE ROW

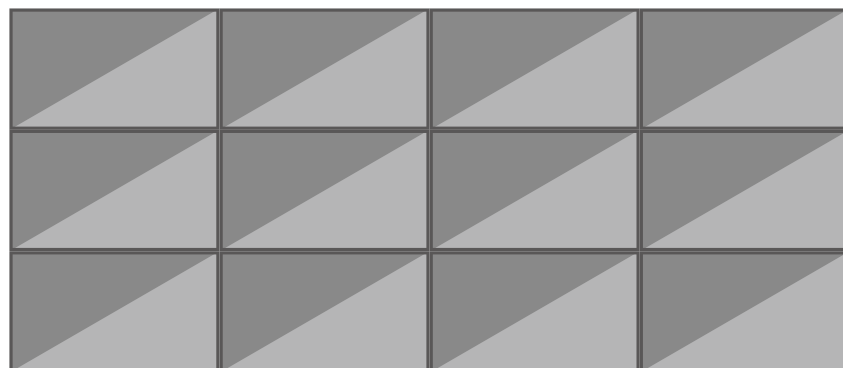

TILED DISPLAY PATTERN



Standard Poles
perfect for creating a Single Row of Displays.



Poles with Weight-Balancing
perfect for Tiled Display Pattern installations.

COMPONENT-BASED CONFIGURATIONS

CEILING-MOUNTED SOLUTIONS

CEILING PLATE

LVC03-W01

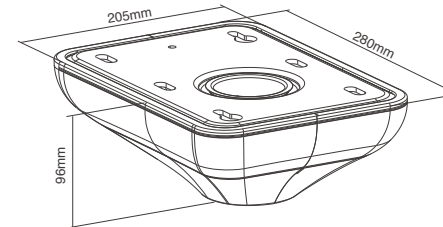

Keyhole Pattern Design
for easy "hook-on" attachment

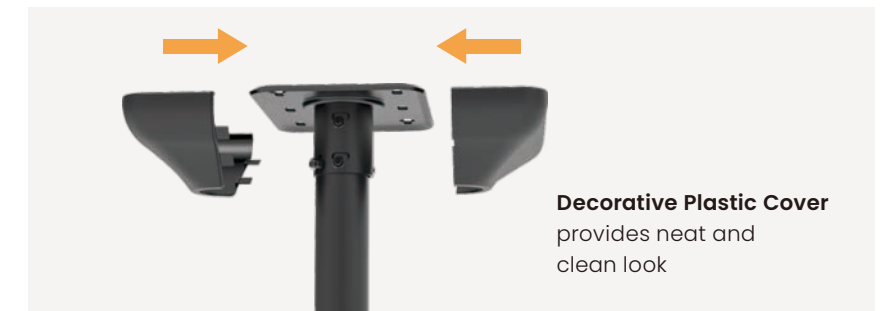

Decorative Plastic Cover
provides neat and clean look

RAIL-TO-POLE COLLAR

LVC03-W02

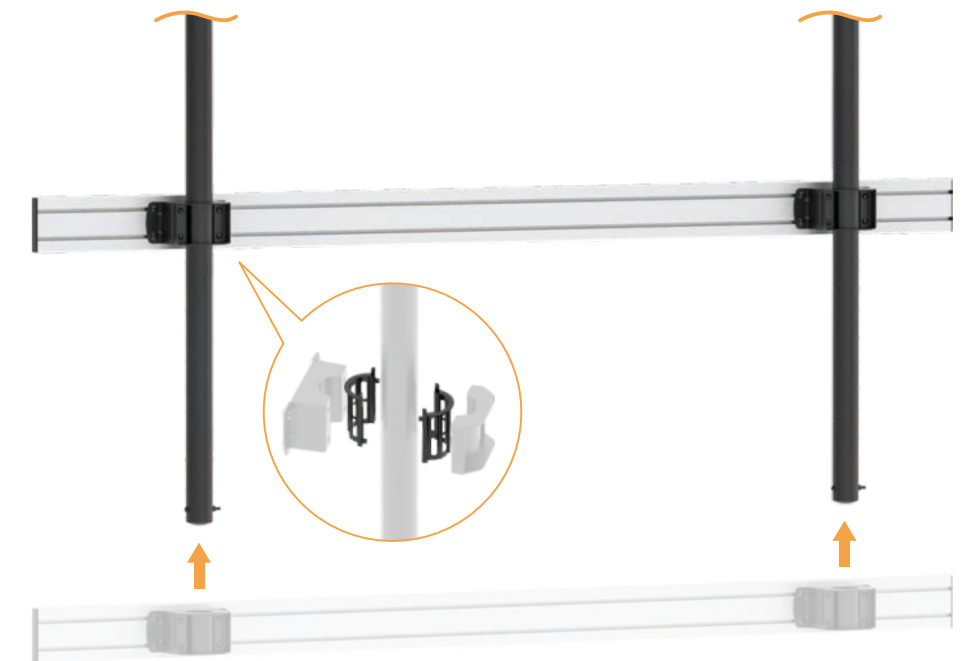
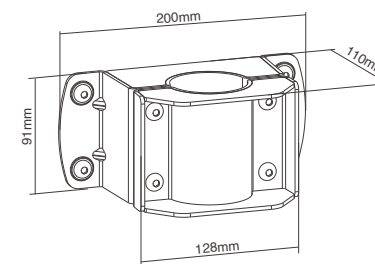

Built-In Anti-Scratch Pads
prevent poles from scuffing while installation



WALL-MOUNTED SOLUTIONS

COMPONENT-BASED CONFIGURATIONS
WALL-MOUNTED SOLUTIONS

ALUMINUM RAILS

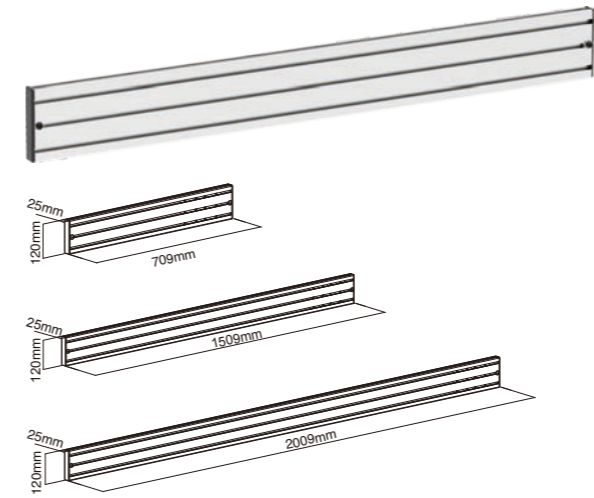

LVS02-R70

700mm

LVS02-R150

1500mm

LVS02-R200

2000mm



(Extension Kits Included in the Rail's Package)

Basic Installation Overview for Wall Mounts

The following information provides an overview of the necessary components required to install a typical wall mount display.

1 Brackets

Choose from Fixed, Tilt and Micro-Adjustment Brackets

2 Wall Plate

3 Aluminum Rails

WALL PLATE

LVS02-W01

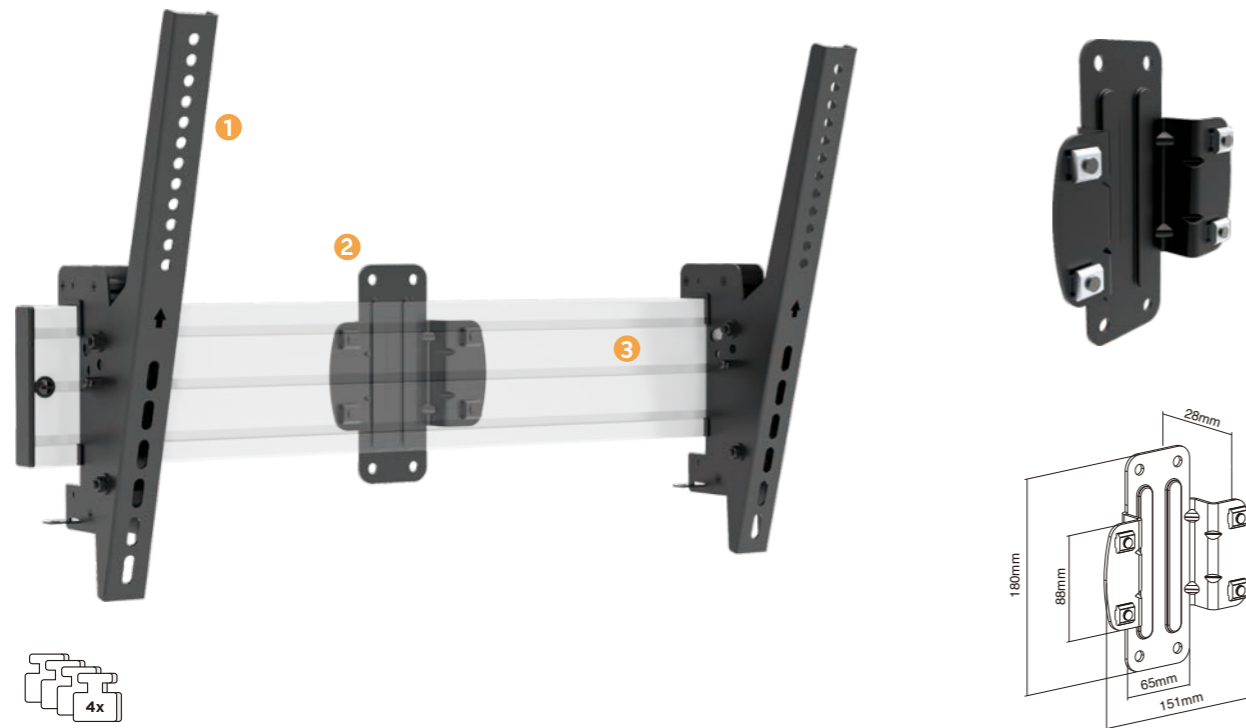

4x
Four Times
Strength Tested

BRACKETS

LVS02-20F/60F/80F/120F

Fixed Bracket

LVS02-40T Tilt Bracket

2.0"
Ultra-Slim Profile



Tool-Free
Tilt Adjustment

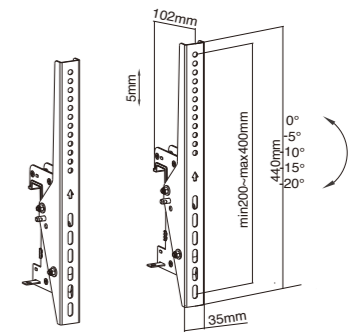

LVS02-40M Micro-Adjustment Bracket

Tool-Free
Precise Alignment

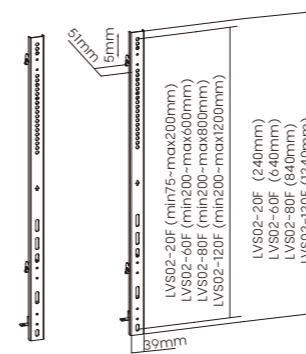
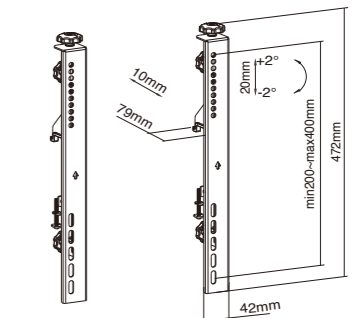

Item No.	Max. Vertical VESA	Screen Size
LVS02-20F	200	23"-47"
LVS02-40T/40M	400	40"-70"
LVS02-60F	600	37"-80"
LVS02-80F	800	65"-120"
LVS02-120F	1200	60"-120"



MOBILE & FIXED SOLUTIONS

Basic Installation Overview for Fixed / Mobile Floor Stand

The following guide demonstrates the necessary components required to create a mobile or fixed floor stand.

- 1 Connecting Plate**
Joins rails to the columns
- 2 Brackets**
Choose from Fixed, Tilt and Micro-Adjustment Brackets
[For More Details - See Page D10](#)
- 3 Aluminum Column**
- 4 Base**
Choose from Leveling Feet, Mobile Casters, Bolt-Down Base and Pedestal Base
[For More Details - See Page D13-D14](#)
- 5 Aluminum Rails**

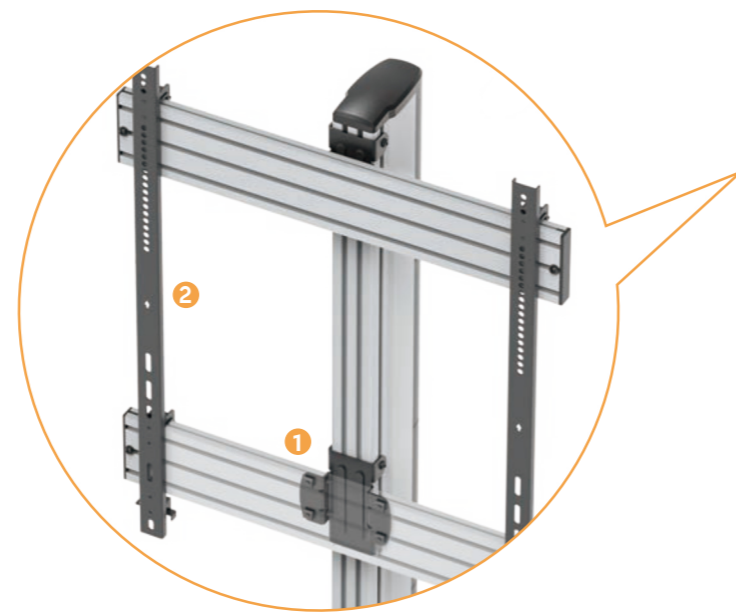

4x
Four Times
Strength Tested

COMPONENT-BASED CONFIGURATIONS

MOBILE & FIXED SOLUTIONS

FLOOR BASE

LVS02-B03 Permanent Fixed Base

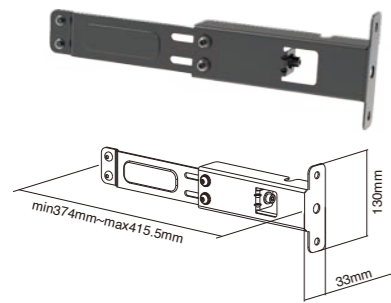

1 Wall Mount Kits included to provide added safety

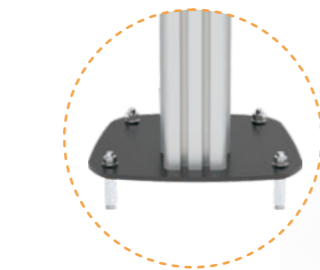
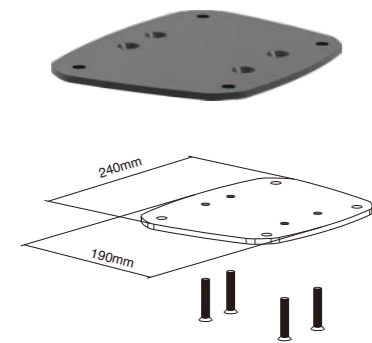

2 Small Footprint Bolt-Down Base an ideal choice when space is limited



LVS02-B01 Floor Base with Leveling Feet

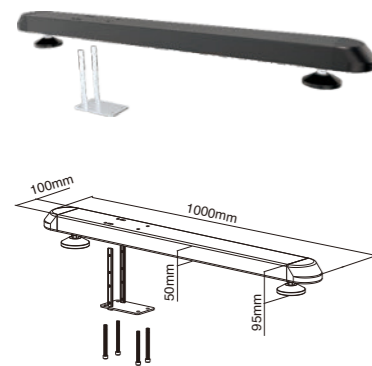

Adjustable Leveling Feet maintains stability even on uneven floors

LVS02-CASTER 3" Mobile Caster

Each caster confidently holds up to **110kg/242lbs!**

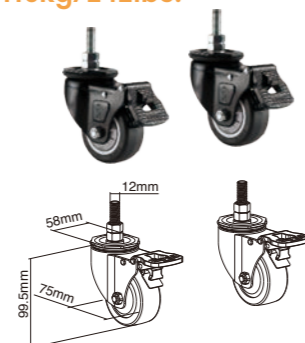

3" PU Hooded Locking Casters used to replace the leveling feet on the LVS02-B01 to create a mobile solution

LVS02-B02 Pedestal Base

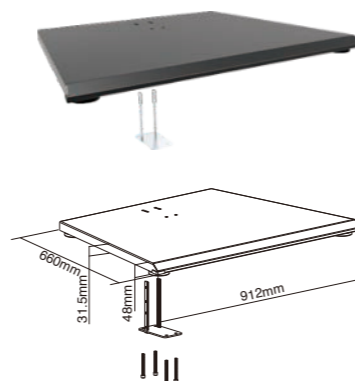

Heavy-Duty Pedestal Base Large size provides increased stability with a low profile to the ground **16.8mm(0.66")**

COMPONENT-BASED CONFIGURATIONS

MOBILE & FIXED SOLUTIONS

LVS02-B04 H Style Base with Caster

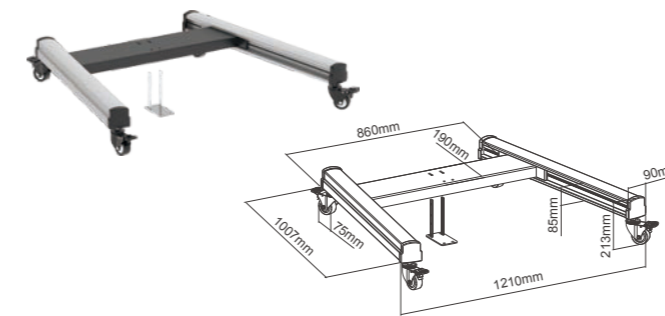

LVS02-B05 H Style Base with Leveling Feet

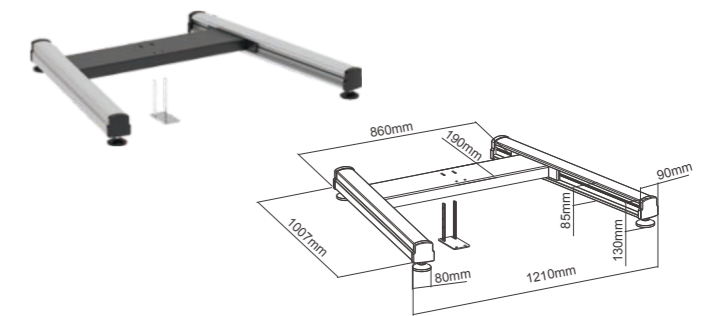

ALUMINUM COLUMNS

LVS02-C18 1800mm

LVS02-C24 2400mm

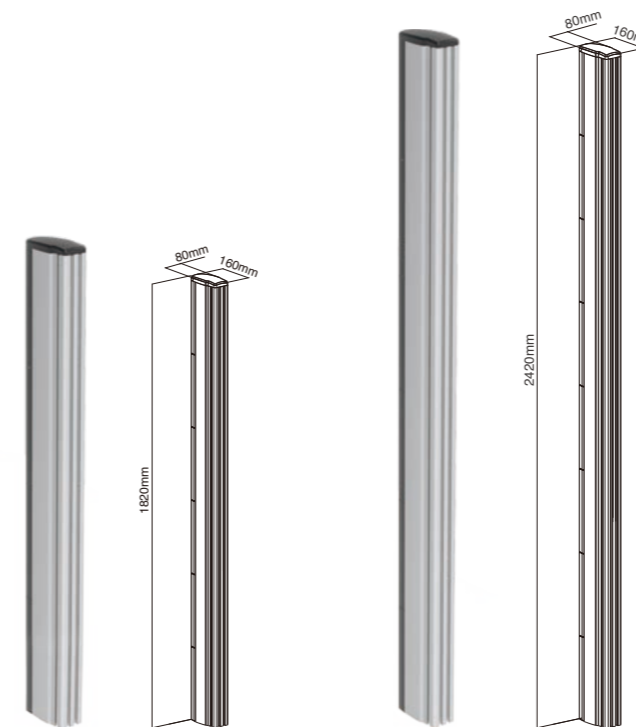

Made of High-Grade Aluminum that can be cut to exact length



Rear Side Slot for mounting additional power socket (19" 1U)

Integrated Cable Covers for a neat and tidy finish

RAIL-TO-COLUMN CONNECTOR

LVS02-J01

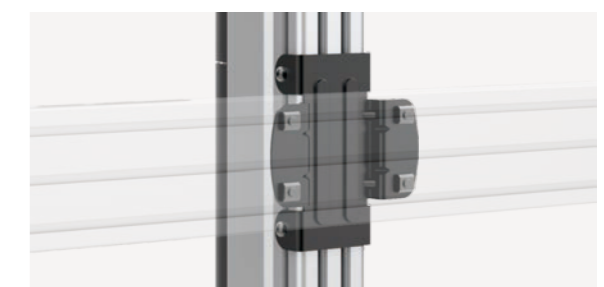
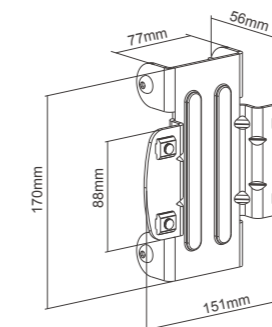

Allows the rails to be positioned anywhere along the length of the column.



LVS02-CM01



Camera Shelf Can be Placed Above Displays for perfect eye contact during your meetings



LVS02-J02



Angle Adjustment Rail Connector for curved multi-screen display

Our aim is to consistently improve and create digital signage display products that increase installation flexibility while building sales and profits for the reseller. Contact XoXoo for any standard or unique application and we can provide you with the correct parts required for mounting pattern being installed. **XoXoo is here to help you!**

Base-Supports for FLOOR, CEILING and WALL Installations



LVS02-B01
Floor Base with Leveling Feet



LVS02-CASTER
3" Mobile Casters



LVS02-B03
Permanent Fixed Base



LVC03-W01
Ceiling Plate



LVS02-B02
Pedestal Base



LVS02-B04
H Style Base with Caster



LVS02-B05
H Style Base with Leveling Feet



LVS02-W01
Wall Plate

Brackets

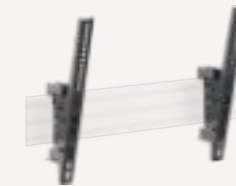

LVS02-40T
Tilt Bracket



LVS02-20F/60F/80F/120F
Fixed Bracket

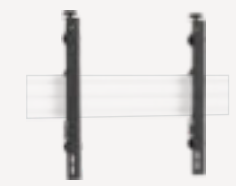

LVS02-40M
Micro-Adjustment Bracket

Components for Connecting & Mounting



LVS02-R70 (700mm)
LVS02-R150 (1500mm)
LVS02-R200 (2000mm)
Aluminum Rails



LVS02-C18 (1800mm)
LVS02-C24 (2400mm)
Aluminum Columns



LVC03-C175-1 (1750mm)
LVC03-C225-1 (2250mm)
Poles with Weight-Balancing



LVC03-C100-2 (1000mm)
LVC03-C150-2 (1500mm)
Standard Poles



LVS02-J01
Rail-to-Column Connector



LVC03-W02
Rail-to-Pole Collar



LVS02-CM01
Adjustable Camera Shelf



LVS02-J02
Angle Adjustment Rail Connector



APM-10-01
Sliding AV Storage Panel