

## Mazda Miata/323 Adaptor Kit – CEV5148

CEV5148



### Overview

All adapters retain use of original clutch and fit most NetGain Hyper9, WARP 9 and HPEV AC34/AC35/AC50/AC51 Motors. Some adapter plates may have more or less bolt holes than your make and model of vehicle requires. As some adapters span a broad range of model years the adapter is designed to have enough bolt holes to be compatible with all model designs.

### Specifications

- All adapter kits come with required hardware
- If using a HyPer9 motor, you may also need a shaft collar spacer, which is included

## Compatible Vehicles – Mazda Miata/323 Adaptor Kit CEV5148

- 1999-2000 Mazda MX-5/Miata
- 2004-2005 Mazdaspeed MX-5 (turbo)
- 1989-1994 Mazda Familia GT-X (Japan)
- 1989-1994 Ford Laser TX3 turbo (Australia)
- Ford Laser GT-X
- 1989-1994 Mazda Familia GT (European & Australian Market)
- 1989-1994 Ford Laser TX3 (Australian Market)
- 1994-1998 [Ford Laser KJ GLXi] (Australian Market)
- 1990-1994 Mazda Protege LX (with VICS)
- 1995-1998 Mazda Protege ES (Australian Market: 1994-1998 323 Protege SE)
- 1990 Mazda Infini
- 1990-1991 and 1993 Mazda Protege GT (Canadian Market)
- 1990-1993 Mazda 323 (European Market)
- 1991-1996 Ford Escort GT and LX-E
- 1991-1996 Mercury Tracer LTS
- 1995-1997 Kia Sephia RS, LS, GS
- 1994-1998 Mazda Familia (Japanese Market)
- 1994-1998 Mazda Lantis
- 1994-1997 Mazda MX-5/Miata (did not have VICS until 1999)
- 1996-1998 Suzuki Cultus Crescent/Baleno/Estee
- 1989-91 Mazda Familia
- 1991-1994 Mercury Capri
- 1994-96 Mazda MX-3
- 1985-1988 Ford Laser, Études, Mazda Familia

# Dimensions – Mazda Miata/323 Adaptor Kit – CEV5148

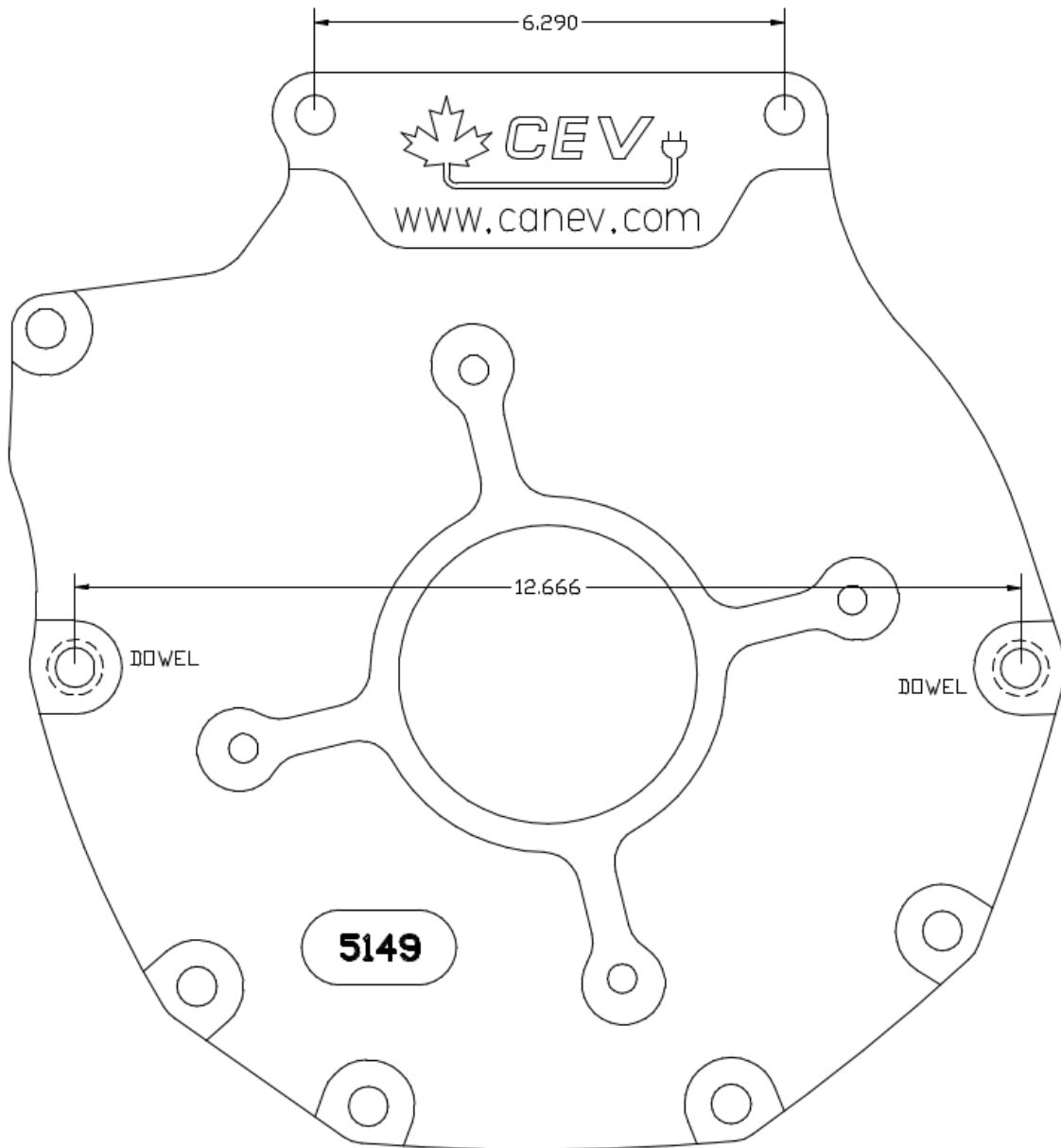

VIEW LOOKING  
TOWARDS TRANSMISSION  
FROM MOTOR

IDENTIFICATION DIAGRAM

ENGINE: MAZDA MIATA

DATE DWN: 8NOV2011

# Dimensions – Mazda Miata/323 Adaptor Kit – CEV5148 (cont.)

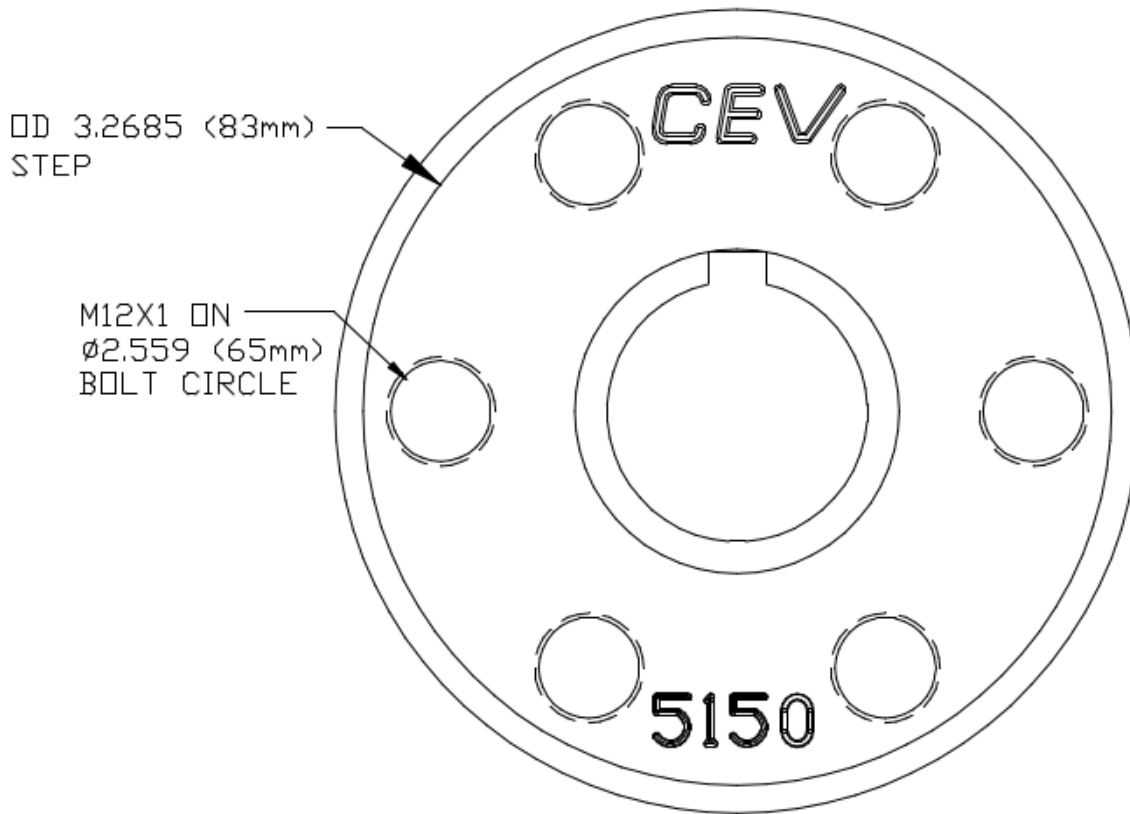

VIEW LOOKING  
TOWARDS MOTOR

HUB IDENTIFICATION DIAGRAM
ENGINE: MAZDA MIATA
DATE DWN: 29JUL2012