



## Ford Ranger 4L 8 Bolt Adaptor Kit – CEV5215



### Overview

canEV adapter kits are designed to simplify your conversion while saving you considerable time and money. Every kit is custom engineered and manufactured in-house to exacting specifications and highest quality standards. Our kits have been used successfully in thousands of conversions for over 2 decades.

canEV's adapters retain the use of original clutch and are designed to be used with "B-Face" motors from NetGain such as the Hyper 9 and WARP 9, and motors from HPEVS like the AC34/AC35/AC50/AC51 Motors.

Some adapter plates may have more or less bolt holes than your make and model of vehicle requires as some kits span a broad range of model years. Some adapters may require trimming or other minor modifications for clearance when used in some applications.

### Notes

All adapter kits come with required hardware however some hardware may not be correct or optimal for all applications. Additional hardware or slightly longer or shorter bolts may be required. This is because the bellhousings are not all the same for all possible fitments of some adapters. Flywheel bolts are generally not included as you can reuse the factory flywheel bolts.

If the Pilot Bearing is installed in the crankshaft it is provided in the kit. Alternatively, if the pilot bearing is installed in the flywheel it is assumed that you will be reusing it or sourcing a new one if needed. If using a Netgain HyPer 9 motor, you will need to install the included shaft collar spacer on the shaft before installing the hub. Some hubs are larger than the motor pilot diameter and must be installed after the adapter plate is bolted to the motor.

## Specifications

<b>Bell Housing Adaptor Plate:</b>	Cast Aluminum
<b>Flywheel Adaptor:</b>	Steel
<b>Motor Pilot Diameter:</b>	4.0"
<b>Motor Bolt Circle:</b>	4 on 8.4"
<b>Motor Shaft Size:</b>	1.125" with 1/4" Square Key

## Adapter may fit the following:

- Ford Ranger 4L with 8 bolt flywheel
- Ford Explorer with 8 bolt flywheel

## Important\*

Buyer must confirm fitment using the drawings below. canEV will not be responsible for return shipping costs and returned product is subject to restocking fees.

## Dimensions – Ford Ranger 4L 8 Bolt Adaptor Kit CEV5215

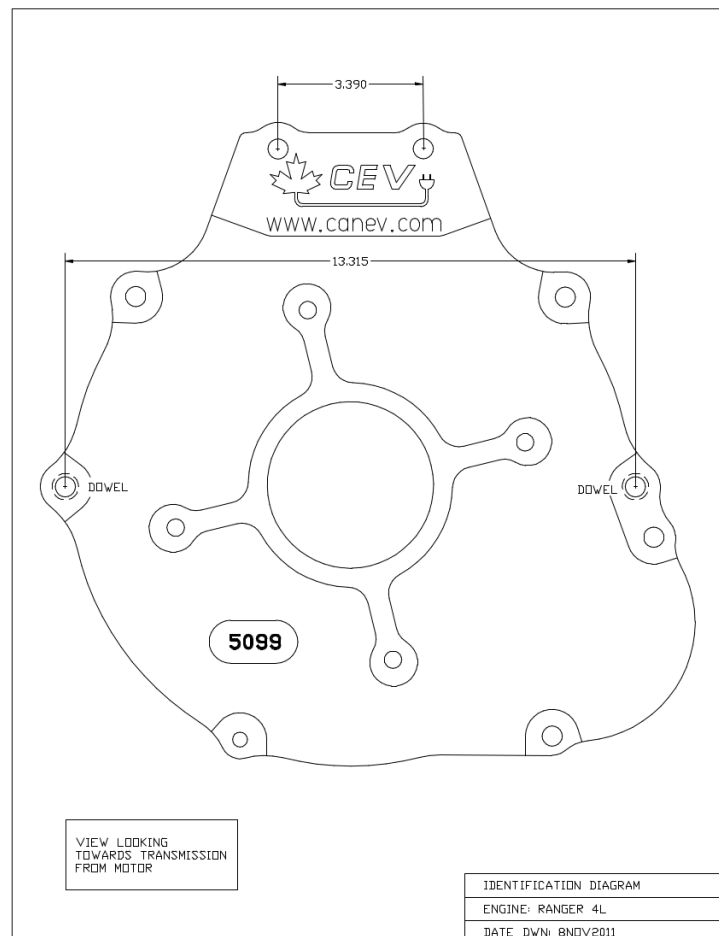

# Dimensions – Ford Ranger 4L 8 Bolt Adaptor Kit CEV5215 (cont.)

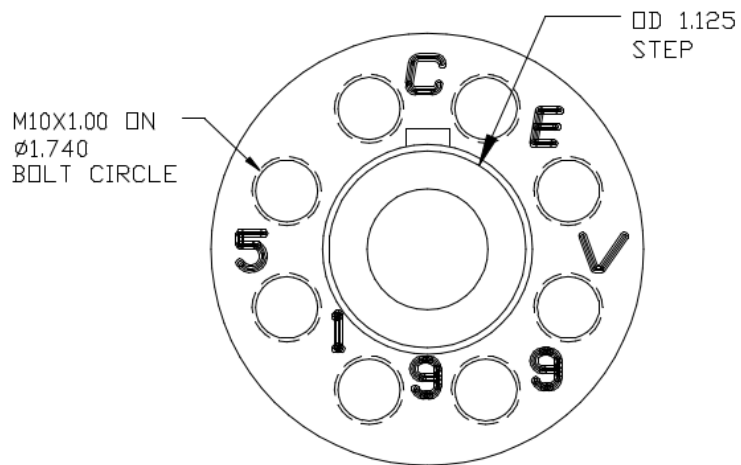

VIEW LOOKING  
TOWARDS MOTOR

HUB IDENTIFICATION DIAGRAM

ENGINE: RANGER 4L 8 BOLT

DATE DWN: 29JUL2012