

Feature details

1. Stopper fixture

We developed this stopper fixture to avoid the need for a 'nut' on our mechanisms that use shafts. This stopper fixture easily integrates into the 'head' section of grinders. Simply pull off the 'head' to refill a mill - with no need to unscrew any bolt. The stopper fixture can securely hold 3Kg (min).

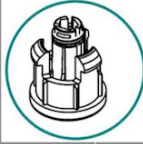

2. Ribs

These carefully designed ribs penetrate into wood in order to prevent rotation of the mechanism without the use of screws. When using this mechanism in plastic materials the purpose of the ribs is the same. However, the geometry of the ribs must be allowed for when designing the inner construction.

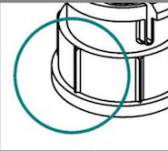

3. Snap-hooks

This mechanism uses snap hooks to mount inside the body easily without the need to use screws.

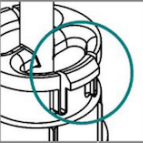

© Copyright by IDEAS Denmark A/S – August 2020 – All rights reserved
May not be reproduced or distributed without our written permission

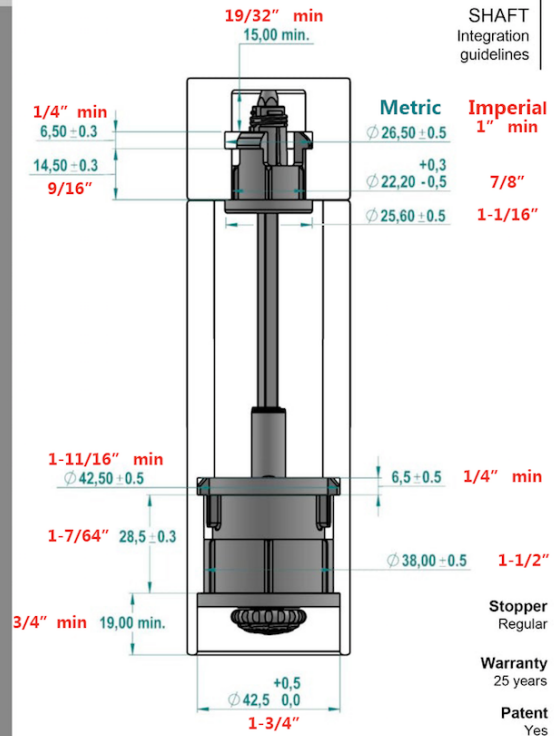

All measurements in mm. Tolerances shown are for mounting into wooden products. Minimum 6mm wall thickness around ribs recommended for wooden products.