

SOPHRO CAPLESS ROLLERBALL PEN

Kit Features

- Capless Schmidt Rollerball Refill
- Streamlined Design with Dual Clip Placement Options
- Easy to Turn with Straight Tubes
- Minimal Parts--easy to assemble
- Available in multiple finishes
- Overall Length: 5-3/16"

Required Accessories

- 7mm Pen Mandrel
- Drill Bit: #PK105MM for Wood, #PK-105MMSG for Plastic
- Bushing Set(2pc): #PKSOPHBU
- Barrel Trimming: #PKTRIM734 with 10.5mm sleeve from #PKTRIMSET or #PKMAJRBTS.
- Live Tailstock or Mandrel Saver
- 2 part Epoxy or Thick CA (Cyanoacrylate) Glue
- Pen Blank Minimum Size: 3/4" x 3/4" x 3-3/16"L



Preparing the Blank:

- Cut blank to the length of the tube, adding 1/16" for squaring off.
- Drill 10.5 mm hole lengthwise through the blank.
- Spread glue over tube, insert the tube into the blank with a twisting motion to spread the glue evenly inside.
- Center the tube lengthwise inside the blank.
- When the glue is dry, square the ends of the blanks, making sure the trimmed ends are 90° to the tube. Use a 10.5 mm trim sleeve with #PKTRIM734 or a pen blank squaring jig on a disc sander. Take the excess material down flush to the ends of the tubes. **Do not trim past the end of the tube** since this may interfere with assembly. Use a barrel trimmer to clean the inside of the tube.

DIAGRAM B / TURNING THE BLANK



Turning the Blank:

- Mount the bushings and blanks according to diagram B.
- When using Mandrel Saver, there is no need for extra spacer bushings or the knurled nut. Slide and lock tailstock directly against bushings and tighten quill until blank and bushings are secure.
- To Used Knurled Nut setup (right), add spacer bushings until past the threads on the end of the Mandrel Shaft.
- Thread on the Knurled Nut and hand tighten to hold all components in place.
- Slide the Tailstock up snugly against the Mandrel shaft, inserting the live center point into the Mandrel dimple.
- Lock Tailstock and hand tighten the quill adjustment with wheel to steady the mandrel. Do not over-tighten, it could damage mandrel shaft.
- Using sharp tools, turn the blank down close to the bushing diameter. Turn the barrel straight or to a profile of your choice.
- Sand the blank down to be flush with the bushings, gradually increasing sandpaper grits.
- Finish the barrel using your choice of polish. Allow sufficient time for the polish to cure—refer to manufacturer's polish instructions.

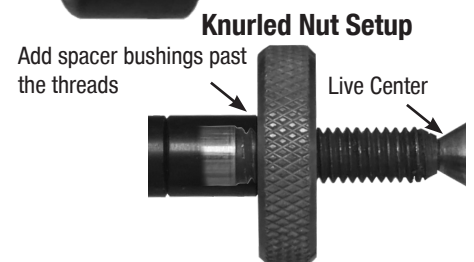

Diagram C / Bushing #PKSOPHBU

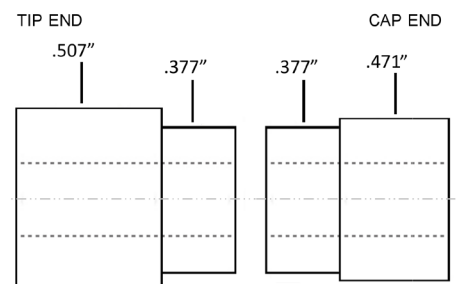
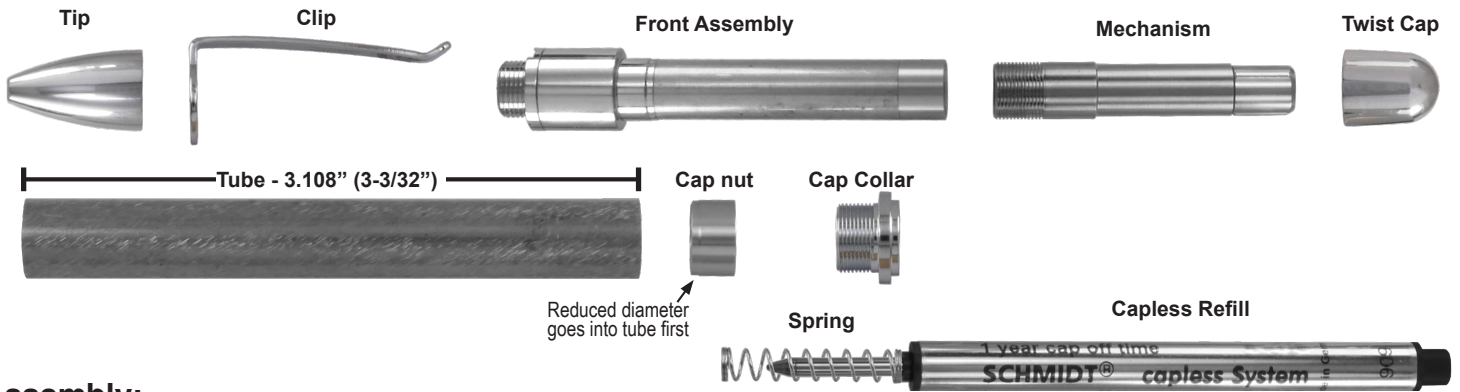
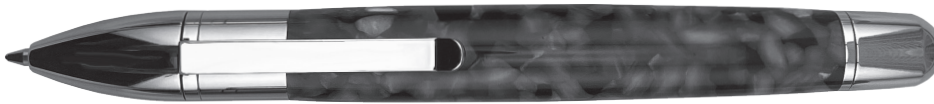

Diagram D / Parts Layout

**Assembly:**

- Press Cap nut, reduced diameter first, into upper, smaller diameter end of Barrel.
- Press Front Assembly into lower, larger end of Barrel.
- Slide Mechanism through Cap Nut and thread into the back of Front Assembly.
- Thread Cap Collar into Cap Nut.
- Push Twist Cap onto the exposed end of the Mechanism.
- Insert capless Refill, back end first, into the open end of the Front Assembly.
- Place Spring over Refill Shaft.
- Place Clip over the threads on Front Assembly and align it with the clip slot according to Diagram E. If you prefer to have the Clip at the back end of the pen as in Diagram F, the Cap Collar can be inserted through it before being threaded into the Cap Nut.
- Thread Tip onto Front Assembly.
- To extend and retract Refill, turn the Twist Cap clockwise and counter-clockwise. Note that Rollerball Ink can leak if it is accidentally left extended and inserted point first into pocket – always remember to retract before putting into pocket!
- Replace the Refill by unthreading the Tip. Take care not to lose the spring when switching to a new Refill.

**Diagram E - Clip in tip**

This configuration can help avoid leaks in the pocket.

**Diagram F - Clip on end cap**

If using this configuration always remember to retract refill.