

# 34" Floor Radial Drill Press



## Operator's Manual

Record the serial number and date of purchase in your manual for future reference.

Serial Number: \_\_\_\_\_ Date of purchase: \_\_\_\_\_

For technical support or parts questions, email [techsupport@rikontools.com](mailto:techsupport@rikontools.com) or call toll free at (877)884-5167

# Operator Safety: Required Reading

**IMPORTANT!** Safety is the single most important consideration in the operation of this equipment. **The following instructions must be followed at all times.**

There are certain applications for which this tool was designed. We strongly recommend that this tool not be modified and/or used for any other application other than that for which it was designed. If you have any questions about its application, do not use the tool until you have contacted us and we have advised you.

## General Safety Warnings

**KNOW YOUR POWER TOOL.** Read the owner's manual carefully. Learn the tool's applications, work capabilities, and its specific potential hazards.

### **⚠ DANGER**



#### **ALWAYS GROUND ALL TOOLS.**

If your tool is equipped with a three-pronged plug, you must plug it into a three-hole electric receptacle. If you use an adapter to accommodate a two-pronged receptacle, you must attach the adapter plug to a known ground. Never remove the third prong of the plug.

#### **ALWAYS AVOID DANGEROUS ENVIRONMENTS.**

Never use power tools in damp or wet locations. Keep your work area well lighted and clear of clutter.

### **⚠ DANGER**



#### **ALWAYS REMOVE THE ADJUSTING KEYS AND WRENCHES FROM TOOLS AFTER USE.**

Form the habit of checking to see that keys and adjusting wrenches are removed from the tool before turning it on.

**ALWAYS KEEP YOUR WORK AREA CLEAN.** Cluttered areas and benches invite accidents.

### **⚠ DANGER**



#### **ALWAYS KEEP VISITORS AWAY FROM RUNNING MACHINES.**

All visitors should be kept a safe distance from the work area.

#### **ALWAYS MAKE THE WORKSHOP CHILDPROOF.**

Childproof with padlocks, master switches, or by removing starter keys.

### **⚠ DANGER**



**NEVER OPERATE A TOOL WHILE UNDER THE INFLUENCE OF DRUGS, MEDICATION, OR ALCOHOL.**

### **⚠ DANGER**



#### **ALWAYS WEAR PROPER APPAREL.**

Never wear loose clothing or jewelry that might get caught in moving parts. Rubber-soled footwear is recommended for the best footing.

### **⚠ DANGER**



#### **ALWAYS USE SAFETY GLASSES AND WEAR HEARING PROTECTION.**

Also use a face or dust mask if the cutting operation is dusty.

### **⚠ DANGER**



#### **NEVER OVERREACH.**

Keep your proper footing and balance at all times.

### **⚠ DANGER**



#### **NEVER STAND ON TOOLS.**

Serious injury could occur if the tool is tipped or if the cutting tool is accidentally

**▲ DANGER****ALWAYS DISCONNECT TOOLS.**

Disconnect tools before servicing and when changing accessories such as blades, bits, and cutters.

**ALWAYS AVOID ACCIDENTAL STARTING.**

Make sure switch is in "OFF" position before plugging in cord.

**NEVER LEAVE TOOLS RUNNING UNATTENDED.****▲ DANGER****ALWAYS CHECK FOR DAMAGED PARTS.**

Before initial or continual use of the tool, a guard or other part that is damaged should be checked to assure that it will operate properly and perform its intended function. Check for alignment of moving parts, binding of moving parts, breakage of parts, mounting, and any other conditions that may affect its operation. A guard or other damaged parts should immediately be properly repaired or replaced.



## Special Safety Rules For Drill Press

1. Do Not operate the Drill Press until it is assembled and you have read the instructions.
2. Do not operate the Drill Press unless you are familiar with its safe operation. If you are not familiar with the operation of a Drill Press seek advice from your supervisor, instructor or other qualified individual.
3. If you are using a bench top Drill Press, it must be securely fastened to a stand or bench.
4. If you are operating a floor Drill Press it must be securely fastened to the floor.
5. Always clear the table and work area before turning on the Drill Press.
6. Always use drill bits, cutting tools and accessories with a 1/2" shank or less.
7. Never place hands near the drill bit, cutting tool or accessory.
8. Never wear loose clothing, gloves or ties while operating the Drill Press.
9. Always have a firm footing while operating the Drill Press.
10. Always keep work surface and work areas clear of debris.
11. Never attempt to do set-up work, assembly or layout work on the Drill Press while it is in operation.
12. Never start the Drill Press with the drill bit, cutting tool or accessory in contact with the work-piece.
13. Always lock all table, column and head locks before turning on the Drill Press.
14. Never operate the Drill Press with a damaged drill bit, cutting tool or accessory.
15. Always check the drill bit, cutting tool or accessory in tight in the chuck.
16. Never operate the Drill Press with the chuck key in the chuck.
17. Always adjust the depth stop to avoid drilling into the table surface.
18. Never drill material unless it is properly supported. Non flat work-pieces require additional support.
19. Always clamp the work piece to the table.
20. Always support large work-pieces at the same height as the table.
21. Never remove the work-piece or clear the table until the Drill Press comes to a complete stop.
22. Always wear a face shield and safety glasses while operating the Drill Press.
23. Never operate the Drill Press with missing, damaged, worn, loose or defective parts.
24. Never adjust, change speeds or perform maintenance on the Drill Press while it is operating.
25. Always clean the work surface and work area when finished operating the Drill Press.
26. Always disconnect the power when adjusting or performing maintenance on the Drill Press.
27. Always disconnect the power when finished using the Drill Press to prevent accidental operation.

**SAVE THESE INSTRUCTIONS.**

**Refer to them often.**

# Table of Contents

Safety Warnings.....	2
Drill Press Safety Rules .....	3
Specifications .....	4
Contents of Package.....	5
Unpacking and Cleaning the Drill Press.....	5
Getting To Know Your Drill Press.....	6
Assembly .....	7
Head Assembly.....	8
Installing/Removing the Chuck and Arbor.....	9-10
Installing the Table.....	10
Adjustment and Operation.....	11
Head Adjustments .....	11
Table Adjustments.....	12
Changing Spindle Speeds.....	12-13
Setting the Spindle Lock.....	13
Setting the Drill Depth.....	13
Maintenance.....	14
Wiring Diagram.....	14
Electrical Requirements.....	15
Troubleshooting .....	16
Parts Explosion .....	17
Parts List .....	18
Notes .....	19
Warranty .....	20

# Specifications

<b>Model No.</b>	<b>30-251</b>
<b>Specifications</b>	
Type	Floor
Horsepower	1/3 HP TEFC
Amps	5.5
Volts	120V, 60 Hz
RPM	1,720
Speed Range (RPM)	620 - 3,100
Speeds	5
Chuck Size	5/8"
Chuck Taper	JT3
Drilling Capacity	5/8"
Spindle Travel	3-1/8"
Spindle Taper	MT2
Head Rotates	360°
Head Tilts	45° Right, 90° Left
Quill Diameter	2-3/16"
<b>Overall</b>	
Table	11-3/16" (Round)
Table Tilts	45°
Table Rotates	360°
Maximum Chuck to Table	28-3/8"
Maximum Chuck to Base	47-3/4"
Column Diameter	2-7/8"
Height	64"
Base Size	18" x 10-1/2"
Net Weight	120 lbs.
Shipping Weight	130 lbs.
Shipping Carton	54-1/4" x 19-1/2" x 10-1/4"
<b>Warranty</b>	<b>5 Years</b>

# Contents of Package

Model 30-251 34" Floor Radial Drill Press is shipped complete in one box.

## TABLE OF LOOSE PARTS

Item	Part Name	Qty
A	Drill Press Head	1
B	Arm	1
C	Table Support	1
D	Table	1
E	Column Assembly	1
F	Base	1
G	Loose Beg	2
H	Chuck	1
I	Owner's manual	1

### 1. Unpacking and Checking Contents

- Separate all "loose parts" from packaging materials and check each item with "Table of Loose Parts" to make sure all items are accounted for, before discarding any packaging material.
- With the help of another person, carefully lift the Drill Press head out of the box.
- Remove protective oil that is applied to the table and column before assembly. Use any ordinary house hold type grease or spot remover.

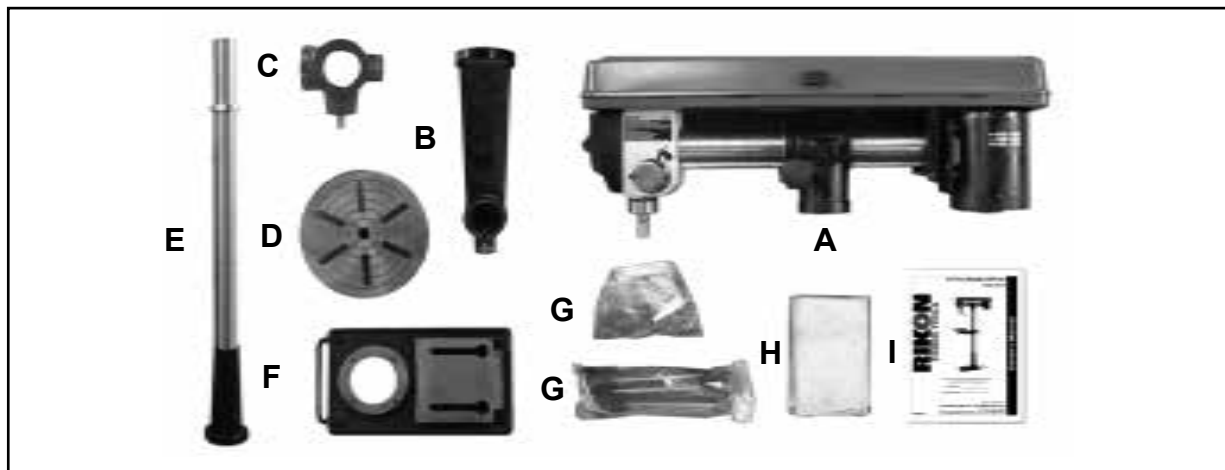

### Tools required for assembly



1. Allen wrenches (provided).



2. Rubber mallet or block of wood and hammer.



3. Adjustable wrench or open end wrench.



4. Household grease remover.



5. Hex. Wrench (provided)

# Getting to Know Your Drill Press

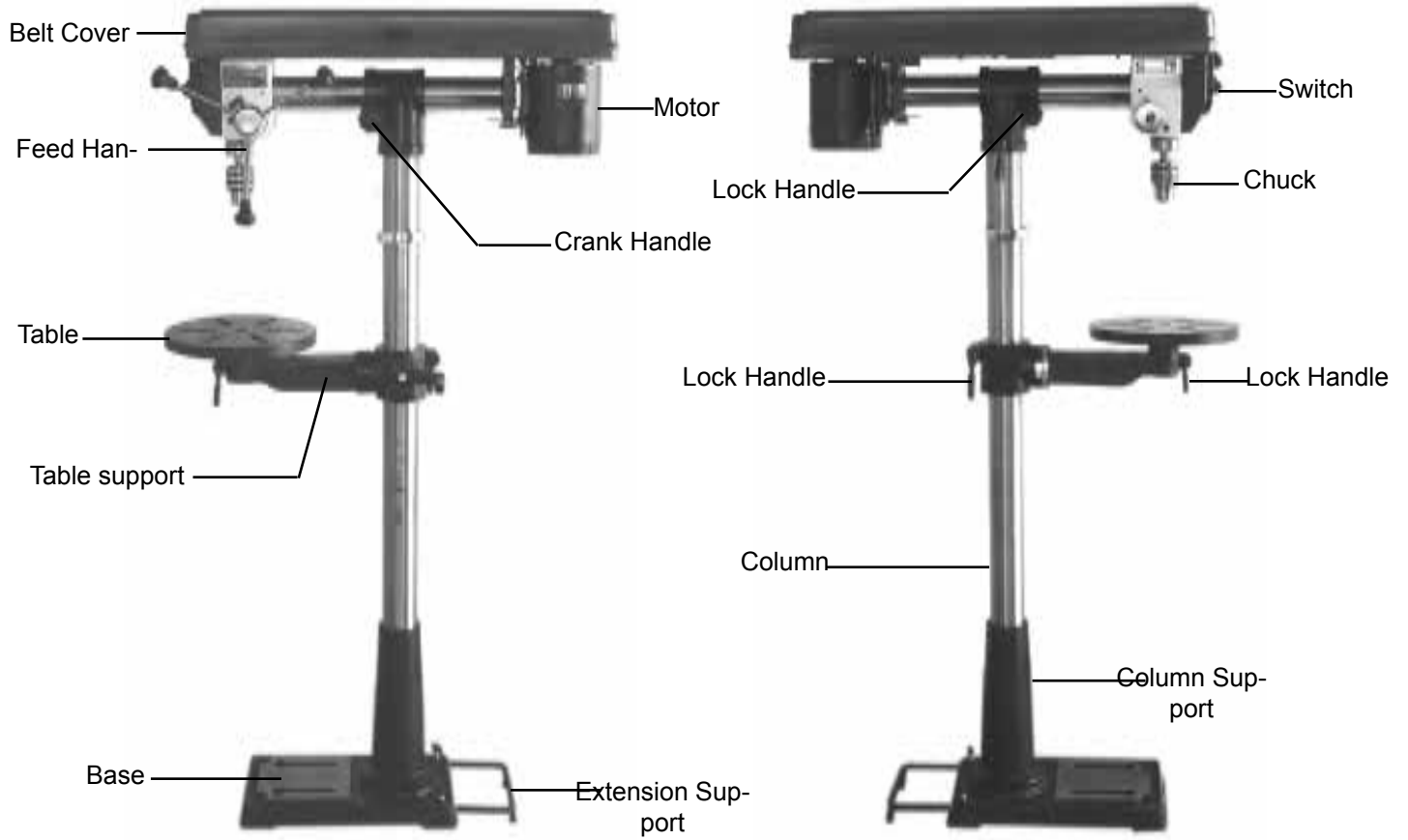

# Assembly

## Base and Column Assembly

1. Place the base (A-Fig. 1) on a level floor where the machine will be used.
2. Attach the column (B-Fig.1) to the base (A-Fig. 1) using four M8x20 hex bolts. Tighten all four bolts.
3. Using an allen wrench (C-Fig. 2) remove the column collar (D-Fig. 2) as shown.
4. Insert the worm elevation gear (E-Fig. 3) into the table support bracket (F-Fig. 3) as shown.
5. Place rack (G-Fig. 4) inside the table support bracket (F-Fig. 4) lining up the teeth as shown.
6. Slide the table support and rack assembly over

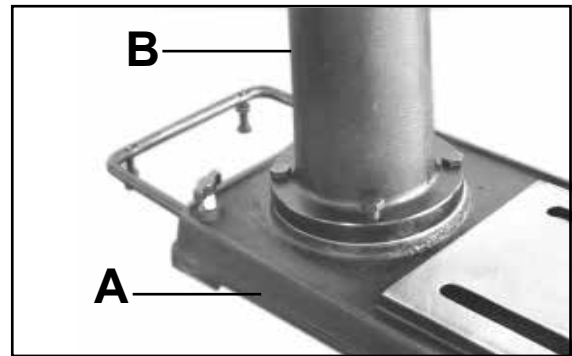

Figure 1

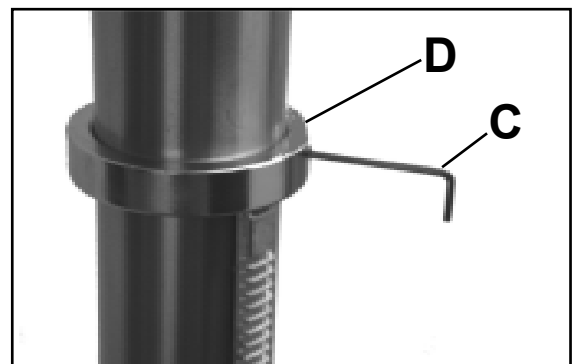

Figure 2

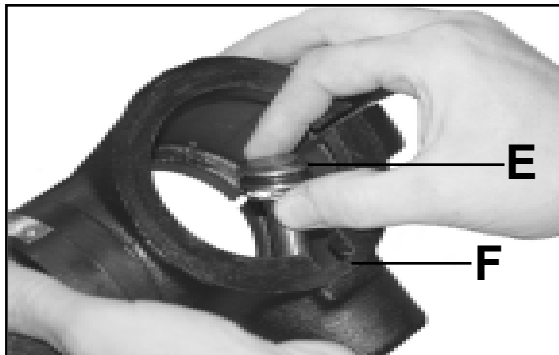

Figure 3

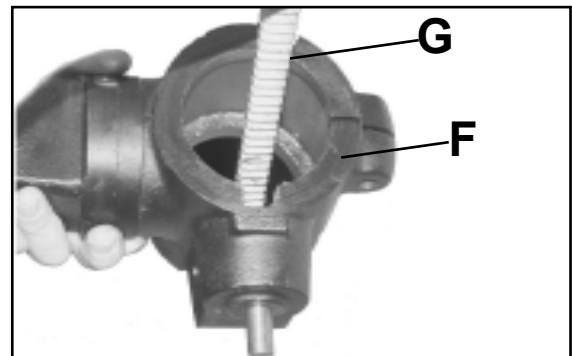

Figure 4

## Head Assembly

1. Place the locking shoe (part# 15B) in the recessed pocket of the head. (Fig. 5)

**Assistance is needed for this next step.**

2. Place the drill press head (A-Fig. 6) onto the column (B-Fig. 6) as far as it will go.

3. Attach the 2 clamping levers (part# 30B) on the drill press column guide (part# 18B). (Fig. 7)

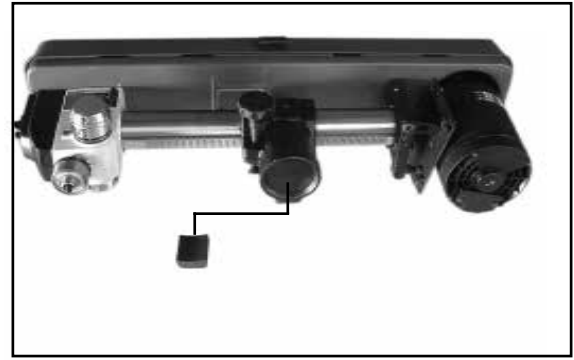

Figure 5

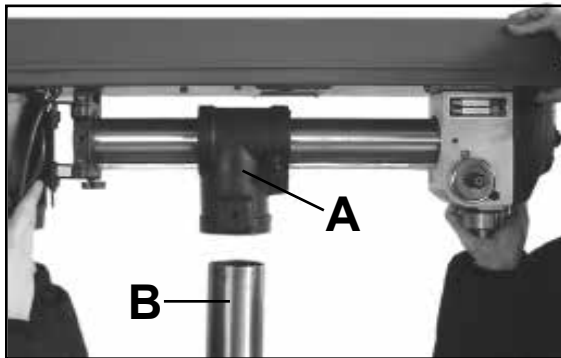

Figure 6



Figure 7

4. Align the drill press head (A-Fig. 8) with the base of the drill press.

5. Tighten the drill press head (A-Fig. 8) to the column (B-Fig. 8) by tightening the locking lever (part# 30B) on the left side of the guide column (part# 18B).

6. Attach the three feed handles (part# 35B) to the hub (part# 36B). Fig. 9

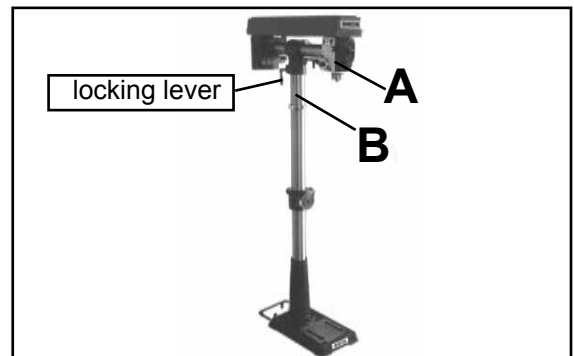

Figure 8



Figure 9



## INSTALLING/REMOVING CHUCK AND ARBOR

**IMPORTANT!** It is important that the chuck and arbor are free of any grease or rust protection. Use ordinary household grease remover.

### INSTALLING THE CHUCK AND ARBOR

1. Open the chuck jaws as wide as possible to prevent any damage. (Fig.10)

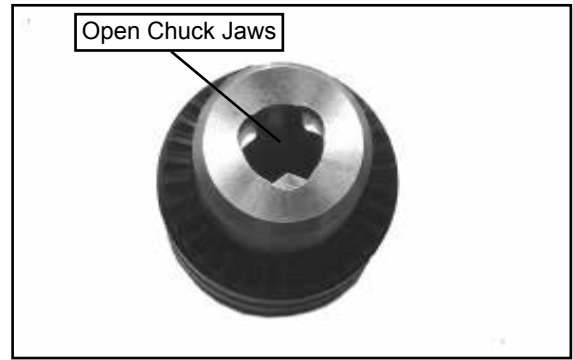

Figure 10

2. Insert the arbor (A-Fig.11) into the chuck (B-Fig.11) as shown.



Figure 11

3. Carefully insert the chuck and arbor assembly into the spindle, making sure to align the flat part of the arbor with the spindle. (Fig. 12)



Figure 12

4. Using a mallet or wood and hammer, drive the chuck and arbor assembly into the spindle. This will properly seat the chuck assembly on the spindle. (Fig. 13)

5. Close the chuck jaws with the chuck key provided.

**NEVER HIT THE CHUCK ASSEMBLY WITH A METAL HAMMER.** This could damage the



Figure 13

## REMOVING THE CHUCK

1. Open the chuck jaws as wide as possible to prevent damage.
2. Lower the spindle until the slot in the spindle is exposed. (Fig.14)
3. Position the table approximately 1/2" below the extended chuck.
4. Turn the chuck until a through hole is exposed in the spindle.
5. Insert the Key-drift provided into the slot. (Fig.15)
6. Gently tap the key-drift with a mallet to release

## INSTALLING THE TABLE

1. Install the arm onto the table support with hex bolt(A-Fig.16) and make sure the scale is on zero position(B-Fig.16). If necessary, adjust the hex socket screw (C-Fig.16) to lever the table 90 degree to the spindle.

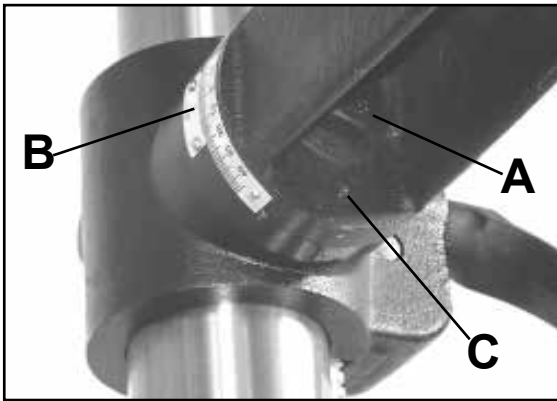

Figure 16

2. Insert the table post (A-Fig.17) into the table support bracket (B-Fig.17) as shown.
3. Tighten the locking lever (A-fig.18) onto the table support bracket (B-Fig.18) and install the table raising/lowering handle (C-Fig.18).

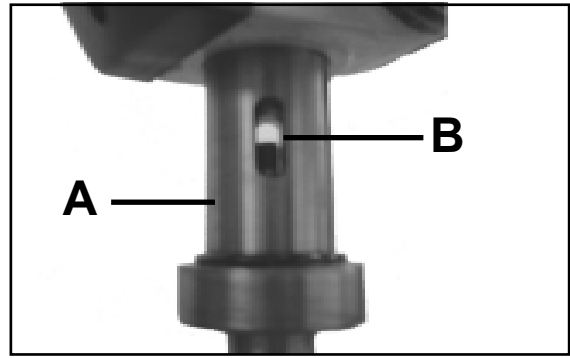

Figure 14

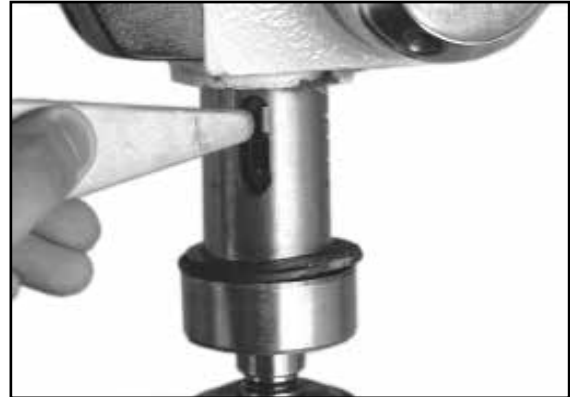

Figure 15

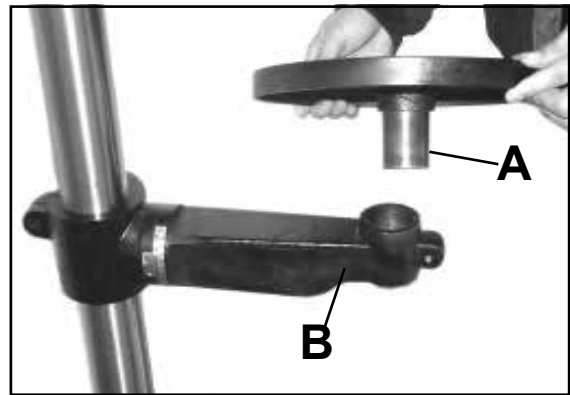

Figure 17

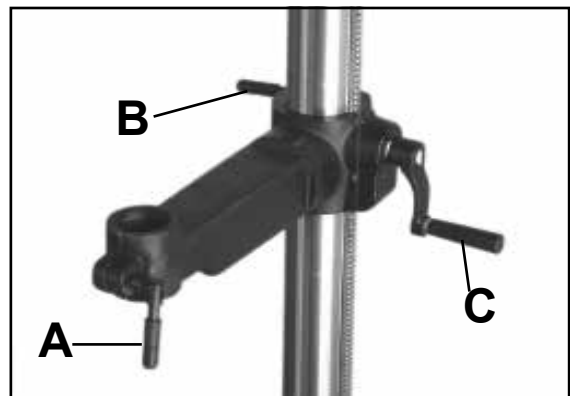

Figure 18

# Adjustment and Operation

## HEAD ADJUSTMENTS

### Tilting the Drill Press Head 45° Clockwise and 90° Counterclockwise

1. Loosen the lock handle (A-Fig.19) on the right side of the drill press head.
2. Pull the guide pin out on the left side of the drill press head (A-Fig.20) and rotate 90°. The head may be tilted to the desired angle.
3. Tighten the lock handle.
4. To return to the original position, loosen the lock handle.
5. Move the head back to a vertical position .
6. Pull the guide pin out and rotate until it seats in the guide pin slot.
7. Tighten the lock handle.

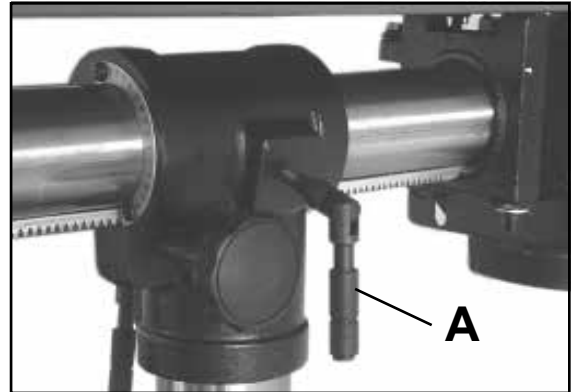

Figure 19

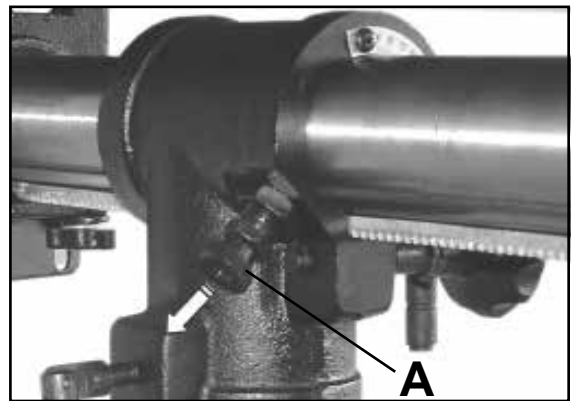

Figure 20

### Adjusting the Drill Press Head Forward and Backwards

1. Loosen the lock handle on the right side of the head.
2. Turn the handle (A-Fig.21,22 ) to the desired position.
3. Tighten the lock handle.

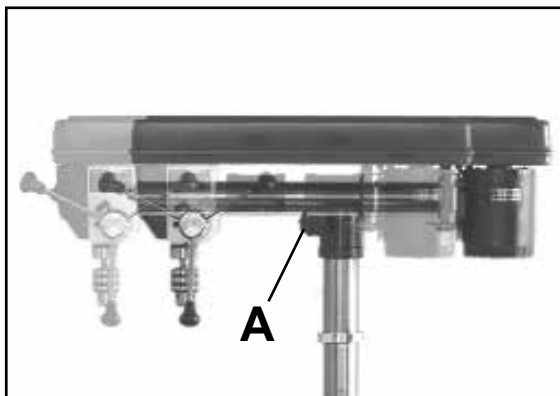

Figure 21

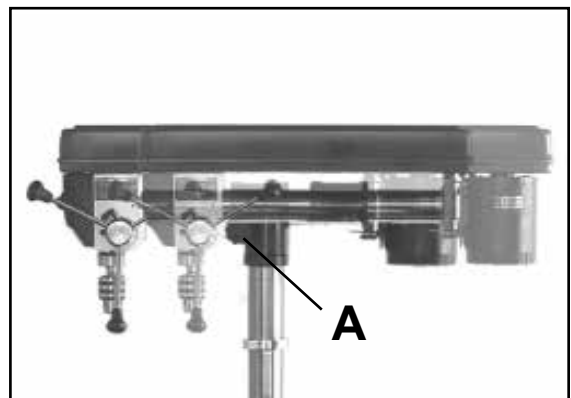

Figure 22

## TABLE ADJUSTMENTS

### Raising and Lowering the Table

1. Loosen the column lock (A-Fig.23) on the table support bracket (B-Fig.23).
2. Turn the crank to raise or lower the table to the desired height.
3. Tighten the column lock (A-Fig.23).

The table can rotate 360° by loosening the table lock handle and turning to the desired position. (Fig. 24)

### TILTING THE TABLE

1. Loosen the nut below the table. (Fig. 25)
2. Tilt table to desired angle.
3. A Tilt scale and pointer are provided on the bracket to indicate the angle.
4. Tighten nut.

### CHANGING SPINDLE SPEEDS

#### **WARNING!**

Disconnect machine from the power source.

1. Turn off and disconnect the power to the Drill Press.
2. Open belt cover.
3. Release the tension on the belt by loosening the belt tension lock (A-Fig.26) and pull forward on the motor (B-Fig. 26).
4. Choose the desired speed by referring to the speed selection chart.

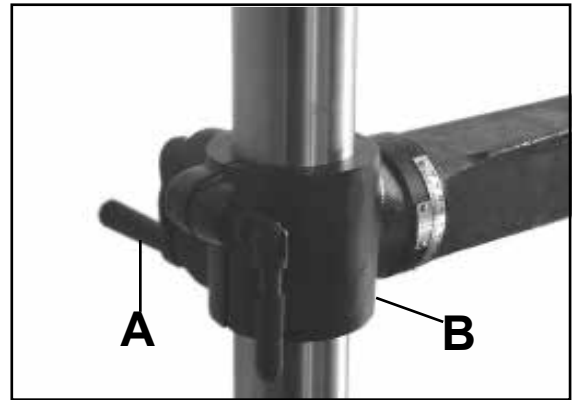

Figure 23

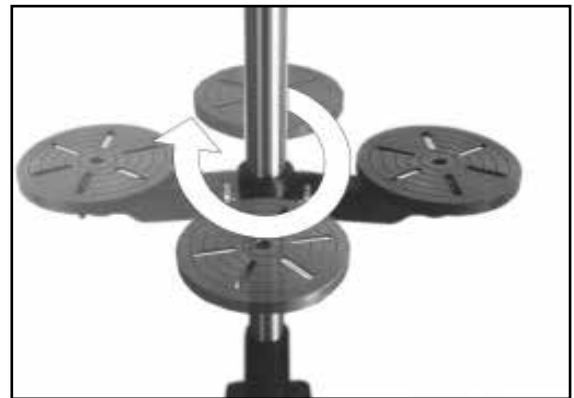

Figure 24



Figure 25

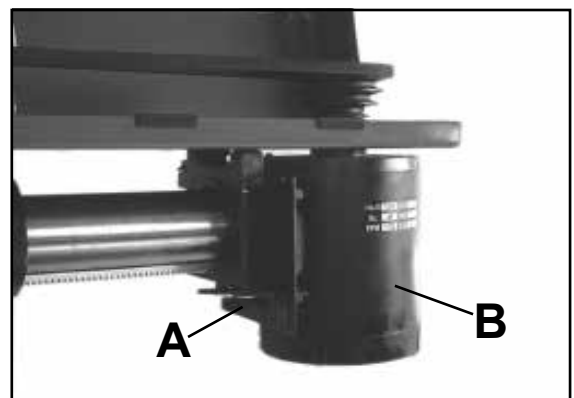

Figure 26

## CHANGING SPINDLE SPEEDS CONT.

6. Place the belt on the pulleys in relation to the speed chosen on the speed selection chart starting with the motor pulley first. (Fig.27)

7. Push back on the motor until there is approximately 1/2" deflection in the belt. (Fig.28)

8. Tighten the belt tension lock handle.

9. Close the belt guard.

10. Reconnect the Drill Press to the power.

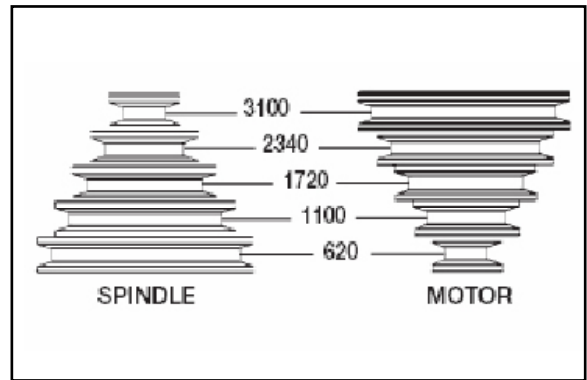

Figure 27



Figure 28

## SETTING THE SPINDLE LOCK

1. Loosen the depth stop collar lock (A-Fig.29) as shown.

2. Lower the spindle to the desired depth. (Fig.30)

3. Turn the depth stop collar clockwise until the collar stops (B-Fig.29).

4. Tighten the depth stop collar lock.

### **NOTE:**

Figure 30 shows the spindle in the locked position.

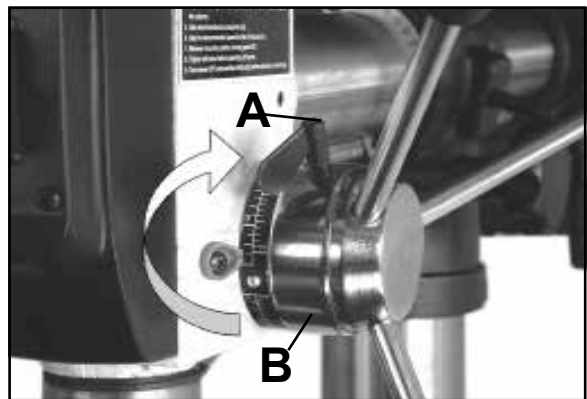

Figure 29

## SETTING THE DRILL DEPTH

1. With the spindle in the up position, loosen the depth stop collar lock (A-Fig.29) as shown.

2. Turn the depth stop collar clockwise until the pointer reads the desired drill depth on the scale (B-Fig.29).

4. Tighten the depth stop collar lock.



Figure 30

## Maintenance

**WARNING:** To avoid injury due to unexpected starting, before cleaning or carrying out maintenance work, switch off and disconnect the drill press from the power source.

1. Never use water or other liquids to clean the drill press. Use a dry brush.
2. Regular maintenance of the drill press will prevent unnecessary problems.
3. Keep the table clean to ensure accurate cutting.
4. Keep the outside of the machine clean to ensure accurate operation of all moving parts and prevent excessive wear.
5. Frequently blow out any dust that may accumulate on the motor.
6. Apply paste wax to the table and column, to help keep the surface clean.
7. Check belts for wear and replace.

## LUBRICATION

All of the ball bearings are packed with grease at the factory. They require no further lubrication.

Periodically lubricate the worm gear (part# 18C) in the table elevation mechanism, the rack bar (part# 2C), and the spline (grooves) in the spindle (part#15A). This will keep the operation of the drill press smooth.

## WIRING DIAGRAM

**WARNING:** This machine must be grounded. To avoid electrocution or fire, any repairs to electrical system should be done only by a qualified electrician, using genuine replacement

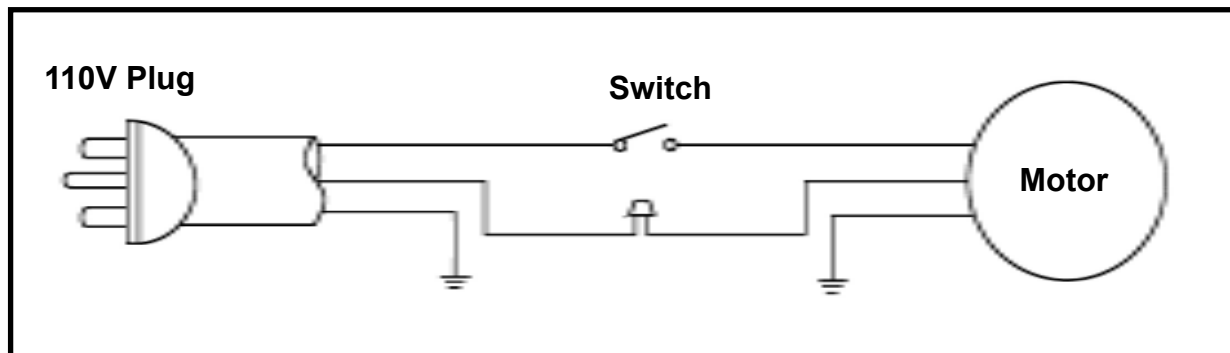

# Electrical Requirements

In the event of a malfunction or breakdown, grounding provides a path of least resistance for electric current to reduce the risk of electric shock. This tool is equipped with an electric cord having an equipment-grounding conductor and a grounding plug. The plug must be plugged into a matching outlet that is properly installed and grounded in accordance with all local codes and ordinances.

Do not modify the plug provided. If it will not fit the outlet, have the proper outlet installed by a qualified electrician.

Improper connection of the equipment-grounding conductor can result in a risk of electric shock. The conductor, with insulation having an outer surface that is green with or without yellow stripes, is the equipment-grounding conductor. If repair or replacement of the electric cord or plug is necessary, do not connect the equipment-grounding conductor to a live terminal.

Check with a qualified electrician or service personnel if the grounding instructions are not completely understood, or if in doubt as to whether the tool is properly grounded.

Use only three wire extension cords that have three-prong grounding plugs and three-pole receptacles that accept the tool's plug.\*

Repair or replace a damaged or worn cord immediately.

This tool is intended for use on a circuit that has an outlet that looks the one illustrated in Figure A below. The tool has a grounding plug that looks like the grounding plug as illustrated in Figure A below. A temporary adapter, which looks like the adapter as illustrated in Figure B below, may be used to connect this plug to a two-pole receptacle, as shown in Figure B if a properly grounded outlet is not available.\*\* The temporary adapter should only be used until a properly grounded outlet can be installed by a qualified electrician. The green colored rigid ear or tab, extending from the adapter, must be connected to a permanent ground such as a properly grounded outlet box.

\* Canadian electrical codes require extension cords to be certified SJT type or better.

\*\* Use of an adapter in Canada is not acceptable.

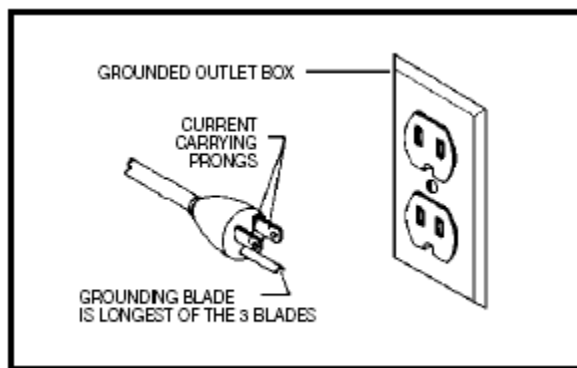

Fig. A

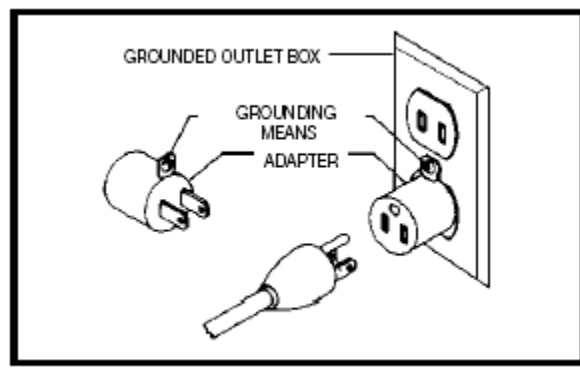

Fig. B

## Trouble Shooting

TROUBLE	PROBABLE CAUSE	REMEDY
Noisy operation	<ol style="list-style-type: none"> <li>1. Incorrect belt tension.</li> <li>2. Dry spindle.</li> <li>3. Loose spindle pulley.</li> <li>4. Loose motor pulley.</li> </ol>	<ol style="list-style-type: none"> <li>1. Adjust tension.</li> <li>2. Lubricate spindle.</li> <li>3. Checking tightness of retaining nut on pulley and tighten if necessary.</li> <li>4. Tighten setscrews in pulleys.</li> </ol>
Drill bit burns material	<ol style="list-style-type: none"> <li>1. Incorrect speed.</li> <li>2. Chips not coming out of hole.</li> <li>3. Dull drill bit.</li> <li>4. Feeding too slow.</li> <li>5. Not Lubricated</li> </ol>	<ol style="list-style-type: none"> <li>1. Adjust speed.</li> <li>2. Retract drill bit frequently to clear chips.</li> <li>3. Resharpen drill bit.</li> <li>4. Faster the speed.</li> <li>5. Lubricate drill bit.</li> </ol>
Drill bit leads off, hole not round	<ol style="list-style-type: none"> <li>1. Hard grain in wood or lengths of cutting lips and/ or angles not equal.</li> <li>2. Bent drill bit.</li> </ol>	<ol style="list-style-type: none"> <li>1. Resharpen drill bit correctly.</li> <li>2. Replace drill bit.</li> </ol>
Wood splinters on underside of workpiece	<ol style="list-style-type: none"> <li>1. No "back up material" under workpiece.</li> </ol>	<ol style="list-style-type: none"> <li>1. Use "back-up material"</li> </ol>
Wood piece pulled loose from hands	<ol style="list-style-type: none"> <li>1. Not supported or clamped properly.</li> </ol>	<ol style="list-style-type: none"> <li>1. Support workpiece or clamp it.</li> </ol>
Drill bit binds in workpiece	<ol style="list-style-type: none"> <li>1. Workpiece pinching drill bit or excessive feed pressure.</li> <li>2. Improper belt tension, belt slips.</li> </ol>	<ol style="list-style-type: none"> <li>1. Support workpiece or clamp it.</li> <li>2. Adjust belt tension.</li> </ol>
Excessive drill bit runout or wobble	<ol style="list-style-type: none"> <li>1. Bent drill bit.</li> <li>2. Worn spindle bearings.</li> <li>3. Drill bit not properly installed in chuck.</li> <li>4. Chuck not properly installed.</li> </ol>	<ol style="list-style-type: none"> <li>1. Use a straight drill bit.</li> <li>2. Replace bearings.</li> <li>3. Install drill bit properly.</li> <li>4. Install chuck properly.</li> </ol>
Quill Returns too slow or too fast	<ol style="list-style-type: none"> <li>1. Spring has improper tension.</li> </ol>	<ol style="list-style-type: none"> <li>1. Adjust spring tension.</li> </ol>
Chuck will not stay attached to spindle, it falls off when trying to install it	<ol style="list-style-type: none"> <li>1. Dirty, grease, or oil on the tapered inside surface of chuck or on the spindles tapered surface.</li> </ol>	<ol style="list-style-type: none"> <li>1. Using a household detergent clean the tapered surface of the chuck and spindle to remove all dirt, grease and oil.</li> </ol>



# Parts Explosion

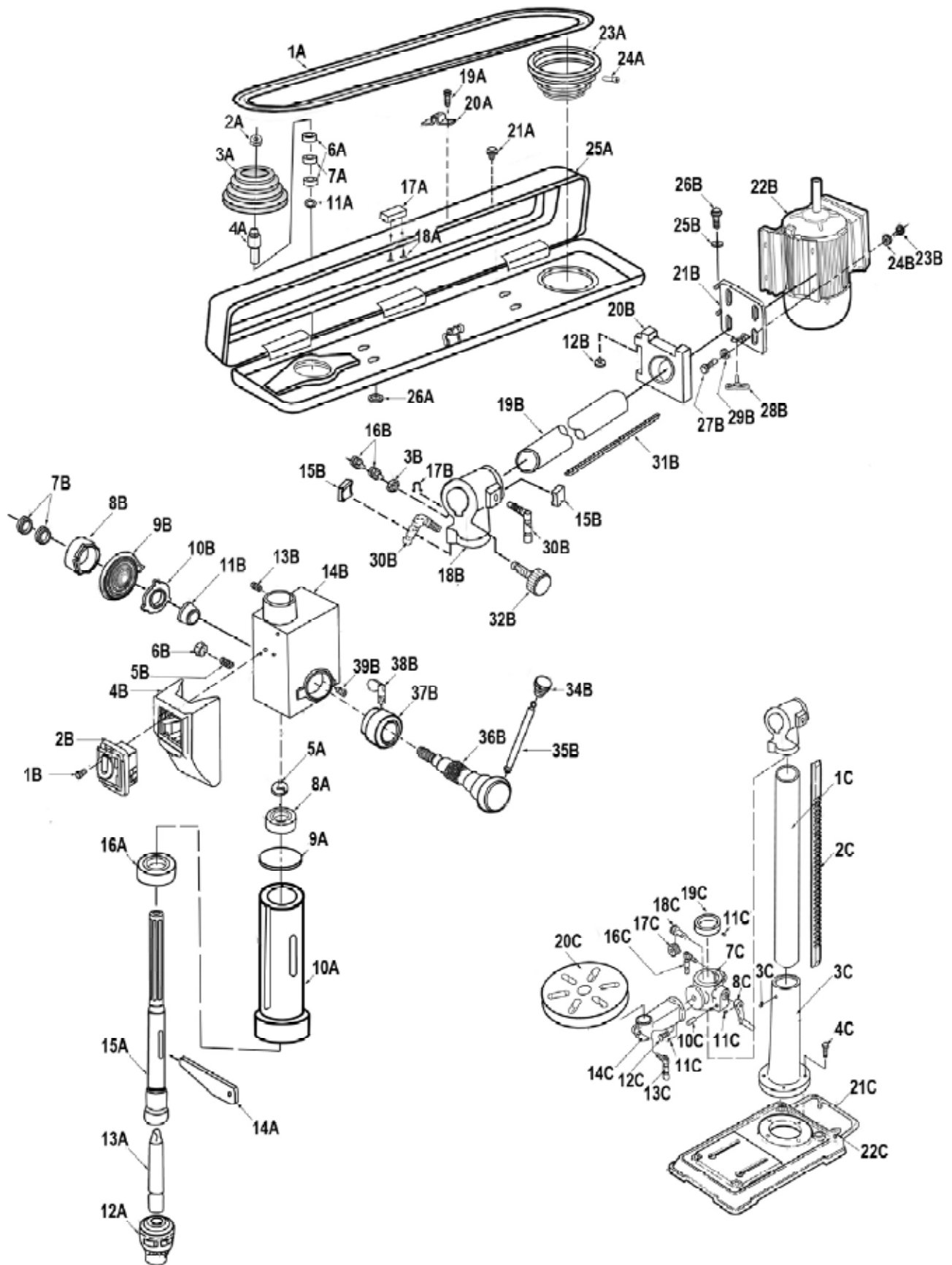

# Parts List

Key No.	Part No.	Description	Key No.	Part No.	Description
1A	1-0405010	BELT-"V"	18B	1-0402002-00001G	GUIDE-COLUMN
2A	1-1302025	PULLEY NUT	19B	1-0401017	HORIZONTAL-TUBE
3A	1-0805006-01001G	SPINDLE PULLEY	20B	1-0402003-00001G	MOUNT-COVER
4A	1-1308022	INSERT PULLEY	21B	1-0402001-00001G	MOUNT-MOTOR
5A	1-CLP11GB894D1B	RING-RETAINING	22B	1-G7812644-00001G	MOTOR
6A	1-BRG80203GB278	BEARING-BALL	23B	1-M8GB6170B	NUT HEX
7A	1-1302023	SPACER 1302023	24B	1-WSH8GB97D1B	WASHER
8A	1-BRG80201GB278	BEARING-BALL	25B	1-WSH8GB97D1Z	NUT HEX
9A	1-1303003	WASHER RUBBER	26B	1-M8X16GB5781B	SCREW-HEX
10A	1-1303002-02	TUBE-QUILL	27B	1-M8X20GB5781B	SCREW-HEX
11A	1-CLP17GB894D1B	RETAINING RING	28B	1-0402005	THUMB NUT
12A	1-Z103116	CHUCK	29B	1-WSH8GB97D1B	WASHER
13A	1-Z402003	ARBOR	30B	1-1501013-01001S	CLAMPING-LEVER
14A	1-1503008	KEY-DRIFT	31B	1-0401018	HORIZONTAL-RACK
15A	1-1303001-01	SPINDLE	32B	1-JL22024001&2-001S	MOVING-BAR
16A	1-BRG80204GB278	BEARING-BALL	34B	1-1504011-01001S	FEED-KNOB
17A	1-0405008-00001S	KNOB	35B	1-1304005-01	FEED-ROD
18A	1-M5X6GB818B	SCREW	36B	1-1304002	HUB
19A	1-M5X12GB818B	SCREW	37B	1-1304003	RING-DEPTH STOP
20A	1-1502014	CLAMP CORD	38B	1-1504012	LOCK-DEPTH SCREW
21A	1-M6X12GB907D1Z	SCREW	39B	1-1304010	PIN-STOP
23A	1-0805005-02001G	MOTOR PULLEY	1C	1-1501003	COLUMN
24A	1-M6X10GB80B	SCREW	2C	1-1501010	RACK
25A	1-0405000-00049W	BELT GUARD	3C	1-M10X12GB80Z	SCREW
26A	1-0403106	FORM WASHER	4C	1-1501002-00001G	COLUMN SUPPORT
1B	1-ST4D2X9D5GB845Z	TAPPING SCREW	5C	1-M10X40GB5781B	HEX BOLT
2B	1-CB-8B	NO-VOLT SWITCH	6C	1-1301001-02001G	BASE
3B	1-JL20061003-001S	NUT	7C	1-1501004-00001G	TABLE SUPPORT
4B	1-U1302008-00001S	BOX SWITCH	8C	1-1501009-10001G&20001S	CRANK
5B	1-1302021	SCREW 1302021	10C	1-1501007	PIN GEAR
6B	1-M8GB6170B	NUT-HEX	11C	1-M6X10GB80B	SCREW
7B	1-1504013	NUT-HEX	12C	1-M16X35GB5781B	HEX BOLT
8B	1-1504008	CAP-SPRING	13C	1-1501013-01001S	TABLE CLAMP
9B	1-1504009	SPRING-TORSION	14C	1-0401005	ARM
10B	1-1504007	RETAINER-SPRING	16C	1-1501012-01001S	SUPPORT CLAMP
11B	1-1504006	SEAT-SPRING	17C	1-1501006	GEAR-HELICAL
12B	1-WSH8GB97D1Z	WASHER	18C	1501008	WORM-ELEVATION
13B	1-M8X8GB80B	SCREW-SOCKET SET	19C	1501011	COLUMN COLLAR
14B	1-0402001-0050B	HEAD	20C	1-1301014-01001G	TABLE
15B	1-0402006	LOCKING SHOE	21C	1-0401023	EXTEND ARM
16B	1-0401025	HEX SCREW	22C	1-1502005	TABLE CLAMP
17B	1-0402004	RING-RETAINING			

# Notes

## Warranty



### 2-Year Limited Warranty

RIKON Power Tools/Richen Enterprise, Inc. (“Seller”) warrants to only the original retail consumer/purchaser of our products that each product be free from defects in materials and workmanship for a period of two (2) years from the date the product was purchased at retail. This warranty may not be transferred.

This warranty does not apply to defects due directly or indirectly to misuse, abuse, negligence, accidents, repairs, alterations, lack of maintenance or normal wear and tear. Under no circumstances will Seller be liable for incidental or consequential damages resulting from defective products. All other warranties, expressed or implied, whether of merchantability, fitness for purpose, or otherwise are expressly disclaimed by Seller. This warranty does not cover products used for commercial, industrial or educational purposes.

This limited warranty does not apply to accessory items such as blades, drill bits, sanding discs or belts and other related items.

Seller shall in no event be liable for death, injuries to persons or property, or for incidental, contingent, special, or consequential damages arising from the use of our products.

To take advantage of this warranty proof of purchase documentation, which includes date of purchase and an explanation of the complaint, must be provided.

The Seller reserves the right to effect at any time, without prior notice, those alterations to parts, fittings, and accessory equipment which they may deem necessary for any reason whatsoever.

To take advantage of this warranty, please fill out the enclosed warranty card and send it to:  
RIKON Warranty  
400 West Cummings Park  
Suite 1000  
Woburn, MA 01801

The card must be entirely completed in order for it to be valid. If you have any questions please contact us at 877-884-5167 or [warranty@rikontools.com](mailto:warranty@rikontools.com).



**For more information:  
400 West Cummings Park, Suite 1200  
Woburn, MA 01801**

**877-884-5167/781-933-8400  
info@rikontools.com  
www.rikontools.com**