

Quick Adjust 6" Tall Rip Fence System



Installation & User Manual

Record the date of purchase in your manual for future reference.

Date of purchase: _____

For technical support or parts questions, email techsupport@rikontools.com or call toll free at (877)884-5167

TABLE OF CONTENTS

Safety Instructions	2
Contents of Package	2 & 3
Parts Diagram & Parts List	3
Assembly	3 - 5
Adjustments.....	5 - 7

SAFETY INSTRUCTIONS

1. The machine must not be plugged in and the power switch must be in the OFF position until assembly is complete.
2. Do not install the 6" Tall Rip Fence System onto your bandsaw until you have read all of the instructions.
3. Installation of this new Fence System must be done according to the following directions to correctly install the parts, and to insure that the future operation of the machine is proper and safe.
4. Any other bandsaw use not as specified, including further modification of the machine or use of parts not tested and approved by the equipment manufacturer, can cause unforeseen damage and invalidate the warranty.
5. Refer to your Bandsaw's originally supplied Operation Manual for complete details on your bandsaw's Safety Instructions, Assembly, Adjustments and Operation.
6. If you are not familiar with the operation of the machine, obtain assistance from a qualified person.
7. Work in a clean, well lit area to keep tools and machine parts organized and safe.

SAVE THESE INSTRUCTIONS.

Store them with your Bandsaw's Operator's Manual for future reference.

CONTENTS OF PACKAGE

Unpacking and Checking Contents

1. Carefully remove all contents from the shipping carton. Compare the contents with the list of parts on the following Parts Diagram and Parts List to make sure that all of the items are accounted for, before discarding any packing material. Place parts on a protected surface for easy identification and assembly.
2. If any parts are missing or broken, please call RIKON Customer Service (877- 884-5167) as soon as possible for replacements. DO NOT start assembling the Fence onto your machine, or use the bandsaw if any of these items are missing. You may cause injury to yourself or damage to the machine.
3. Set packing material and shipping carton aside. Do not discard until the Fence System has been set up on your bandsaw and is operating properly, in case a product return is necessary.

NOTE: The specifications, photographs, drawings and information in this manual represent the current model when the manual was prepared. Changes and improvements may be made at any time, with no obligation on the part of RIKON Power Tools, Inc. to modify previously delivered units. Reasonable care has been taken to ensure that the information in this manual is correct, to provide you with the guidelines for the proper safety, assembly and operation of your machine.

California Prop 65 WARNING: This product contains chemicals known to the State of California to cause cancer and birth defects or other reproductive harm.

For more detailed information about California Proposition 65 log onto rikontools.com.

PARTS DIAGRAM & PARTS LIST

#10-920

Quick Adjust 6" Tall Rip Fence System

NOTE: Please reference the Part Number when calling for Replacement Parts.

For Parts under Warranty, the Serial Number of your machine is required.

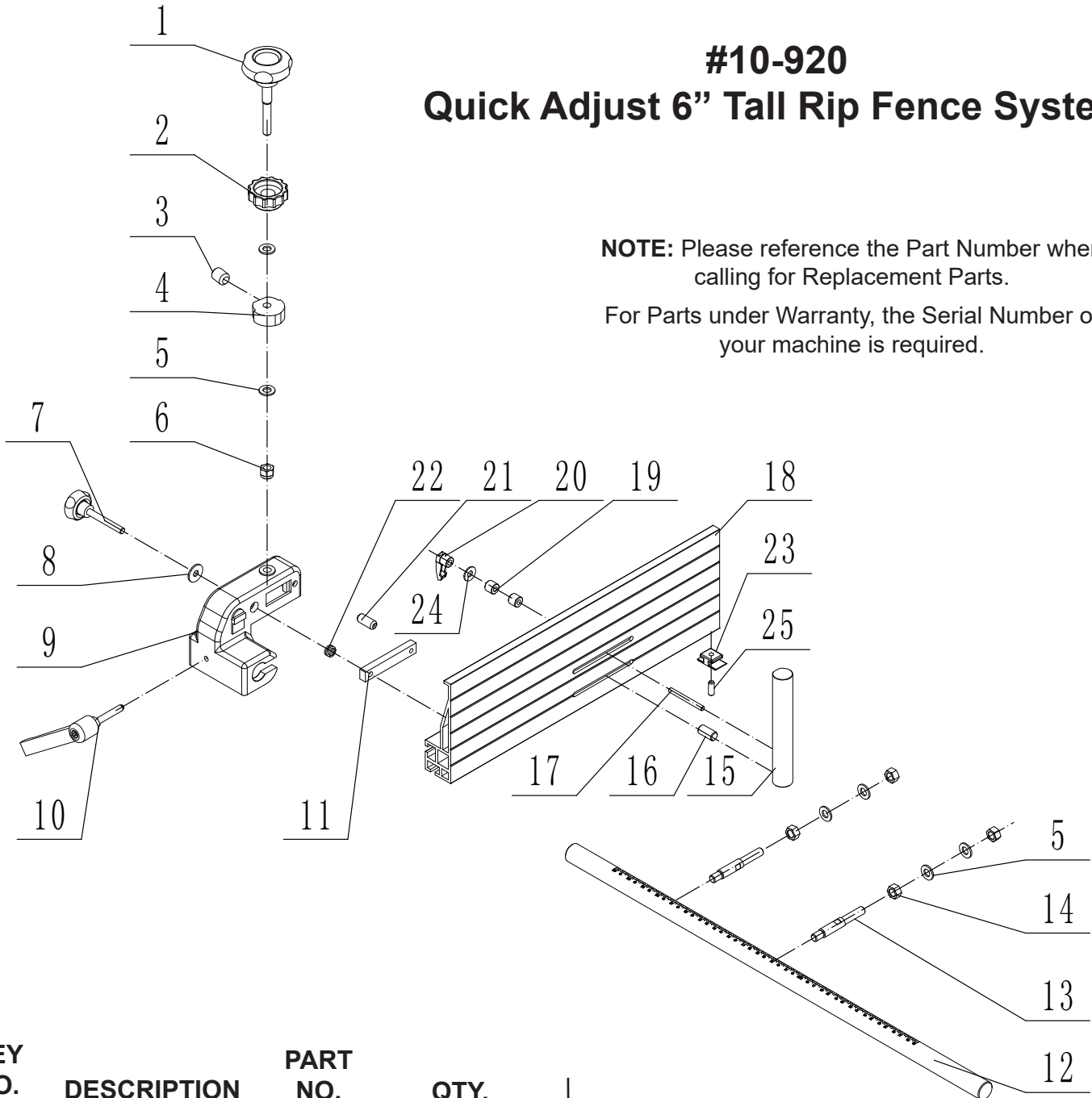

KEY NO.	DESCRIPTION	PART NO.	QTY.
1	Adjusting handle	P10-920-1	1
2	Locking knob	P10-920-2	1
3	Cap screw M8x10	P10-920-3	1
4	Cam	P10-920-4	1
5	Flat washer	P10-920-5	6
6	Nut M10	P10-920-6	1
7	Handle	P10-920-7	1
8	Big washer	P10-920-8	1
9	Rip fence carrier	P10-920-9	1
10	Locking handle	P10-920-10	1
11	Sliding block	P10-920-11	1
12	Front guide rail	P10-920-12	1
13	Connecting rod	P10-920-13	2
14	Hex nut M10	P10-920-14	4

KEY NO.	DESCRIPTION	PART NO.	QTY.
15	Re-saw bar	P10-920-15	1
16	Screw	P10-920-16	1
17	Bolt	P10-920-17	1
18	Rip fence	P10-920-18	1
19	Tube	P10-920-19	2
20	Locking handle	P10-920-20	1
21	Roll pin	P10-920-21	1
22	Spring	P10-920-22	1
23	Nylon plate	P10-920-23	1
24	Washer	P10-920-24	1
25	Set screw	P10-920-25	1

ASSEMBLY



WARNING

THE MACHINE MUST NOT BE PLUGGED IN AND THE POWER SWITCH MUST BE IN THE OFF POSITION UNTIL ASSEMBLY IS COMPLETE.

The 10-920 6" Tall Rip Fence System features a innovative, patent pending 'Quick Adjust Fence System' that will allow you to easily adjust your rip fence to compensate for any 'drift', or blade wandering, that may be experienced when ripping lumber. And the 6" tall extruded aluminum fence will provide extra vertical support when re-sawing lumber. Used in the horizontal position for ripping, it also gives ample space for operator's hands when feeding stock through the cut.

To upgrade your current RIKON bandsaw with this new fence system, please follow the instructions for the removal of the original fence and rail that was supplied with your bandsaw, installation of the new front rail onto your table front skirt and mounting of the fence & carrier assembly. Information on the use of the anti-drift feature and versatility of the fence for ripping needs will also be explained.

TOOLS REQUIRED - to install the new system

- 16mm (5/8") or adjustable wrench
- Measuring ruler to tape with a metric scale
- 14mm (9/16") or larger diameter twist drill and power drill - ONLY required if your bandsaw table's front holes for mounting the new front rail need to be enlarged or newly drilled.

REMOVE THE OLD FENCE

1. Remove the current/old fence and front rail that is mounted on your machine.

NOTE: Refer to your bandsaw's original Operator's Manual for instructions on the proper steps to safely perform this operation on your particular machine model. Tools/wrenches may be required that are not the same size as noted above.

INSTALLING THE FRONT RAIL

Mounting the new front rail onto the front skirt of the table requires that the two mounting holes be 14mm (9/16") or larger in diameter, and positioned as per the dimensions in Figure 1. This will position the front rail so that the '0' calibration on the rail aligns with the center of the slot in the table for the blade for accurate setting of the fence for ripping. It will also position the carrier assembly on the rail so that the fence rides properly above and along the table surface without binding.

1. If needed, enlarge or drill new holes in the table front skirt according to the dimensions in Figure1.

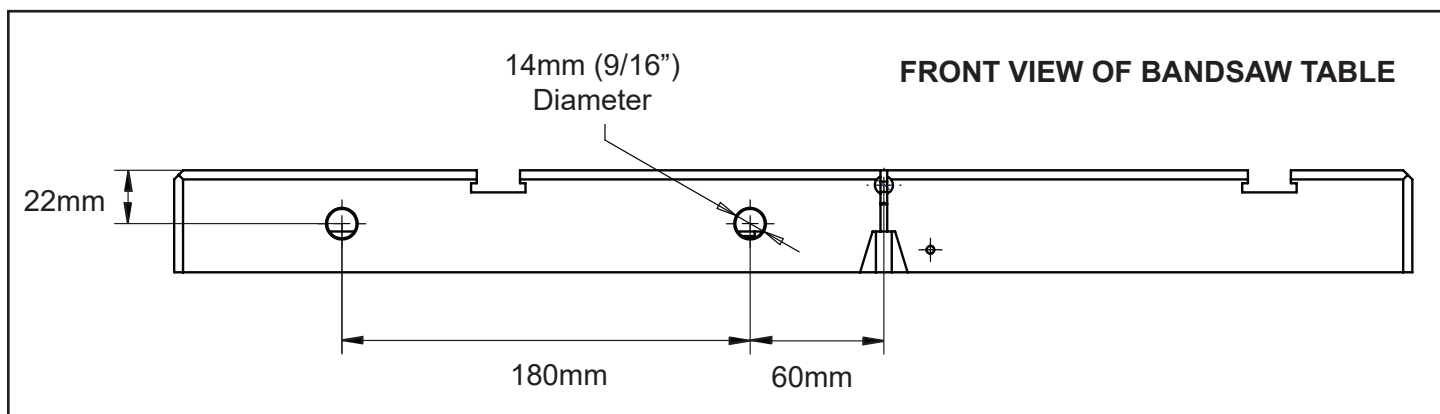

FIGURE 1

ASSEMBLY

2. Mount the fence Guide Rail (#12) onto the front table edge with the two fence Connecting Rods, Nuts and Washers (#13,14, 5) Fig. 2.

Position the bar so that it is parallel with the table surface, and equal distance out from the front edge of the table when measured at both left and right front edges of the table. The '0' calibration on the rail should also align with the center of the slot in the table for the blade.

If there are any positioning issues, adjustments can be made by enlarging the two mounting holes in the table edge so that the bar can be moved a bit more left, right, up or down. A power drill with a metal twist drill or a round metal file can be used to remove excess table material.

DO NOT fully tighten the nuts at this time!

RIP FENCE ASSEMBLY

With the front rail in place, but not fully tightened, assemble the fence carrier and fence onto the rail. Any final adjustments of the rail can then be made by checking that the fence rests evenly along its whole length on the table, and also moves evenly and smoothly along the width of the table.

3. Slide the Fence Carrier Assembly (#9) onto the fence's guide rail. Fig. 3.

4. Slide the Rip Fence (#18) onto the fence carrier's Sliding Block (#11) and lock it in place by tightening the fence lock Knob (#7) which is located on the carrier, opposite side to the fence. Fig. 3, A.

5. The carrier with attached fence can now be moved along the rail to check the rail's setting, and make any final adjustments of the rail to its position on the table edge. Once set, tighten the rails nuts (#14) to secure the rail in place.

NOTE: See page 6 for setting the fence at 90° to the table. Additional rail adjustments may be necessary.

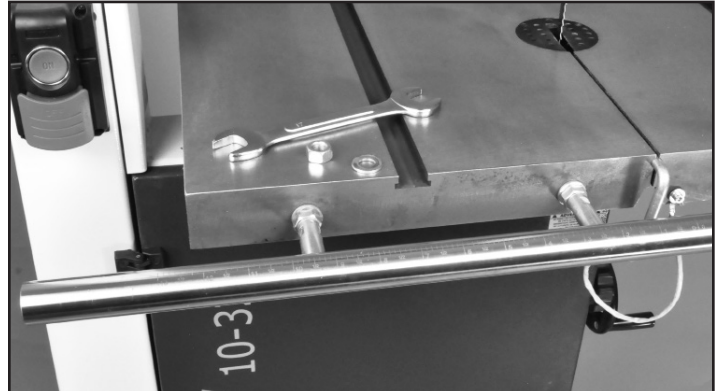

FIGURE 2



WARNING

THE MACHINE MUST NOT BE PLUGGED IN AND THE POWER SWITCH MUST BE IN THE OFF POSITION UNTIL ALL ADJUSTMENTS ARE COMPLETE.

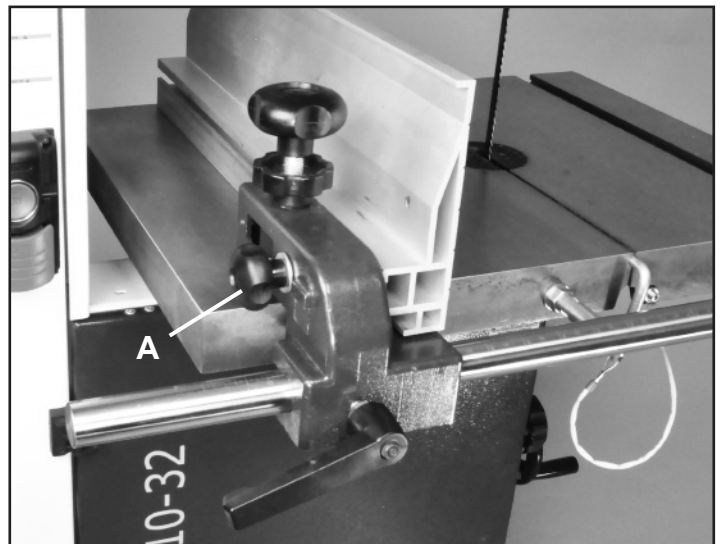

FIGURE 3

6. With the front Locking Handle (#10), the fence assembly can be secured in place on the rail so that it does not move during bandsaw use. Adjustments to the fence are covered on the following pages.

ADJUSTMENTS

ADJUSTING THE RIP FENCE FOR DRIFT

The 10-920 Bandsaw Rip Fence System features an innovative fence carrier that will easily adjust to eliminate 'drift', and bring the fence back to being parallel to the blade. Plus, it allows quick changing of the fence from a vertical to horizontal position, or for use to the left or right of the blade. To adjust the fence for drift:

CONTINUED ON PAGE 6

ADJUSTMENTS

ADJUSTING THE RIP FENCE FOR DRIFT continued

1. Loosen the side Handle (#7, Fig. 4, A) which holds the rip fence against the Fence Carrier (#9, B).
2. Loosen the Locking Knob (#2, Fig. 4, C).
3. Turn the top Adjusting Handle (#1, D) to position the fence left or right as needed to align it parallel to the blade and miter saw slots in the table. The handle turns a Cam (#4, E) that presses against the fence and pivots it as needed.
4. Once the fence is set, tighten the Handle and Knob that were loosened in steps 1 and 2.

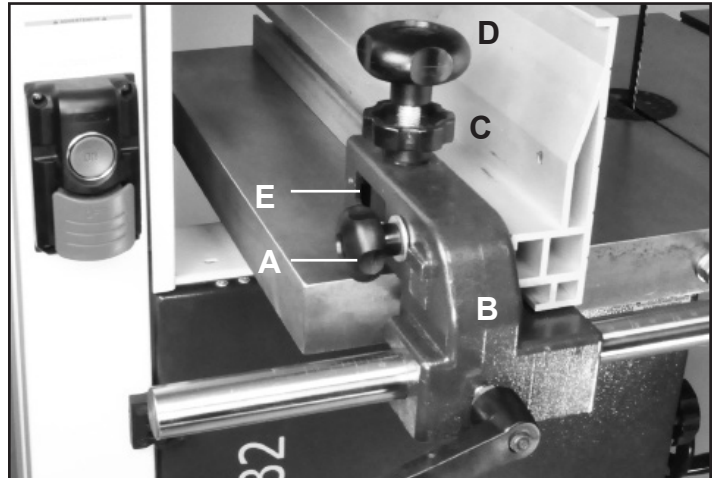

FIGURE 4

ADJUSTING THE FENCE 90° TO THE TABLE

Check that the fence is 90 degrees to the table using a suitable square. If adjustments are required, raise or lower either side of the fence's Guide Rail until the fence body is 90 degree to the table. FIG. 5.

Once set at 90 degrees, fully tighten the fence bar nuts. See page 4 & 5 for the guide rail installation process.

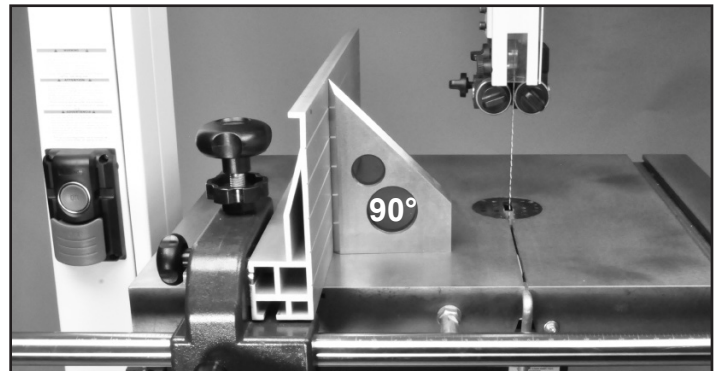

FIGURE 5

ADJUSTING THE FENCE TO THE TABLE

Check that the fence is lying flat or parallel to the table surface. The gap between the table and the bottom of the fence should be equal along the whole length of the fence. The rear, bottom of the fence includes a Nylon Plate (#23) that helps in sliding the fence over the table. A small gap between the fence and table results from this plate. Fig. 6.

If there is a sizeable gap, refer to page 4 & 5 for the mounting and re-positioning of the front fence rail.

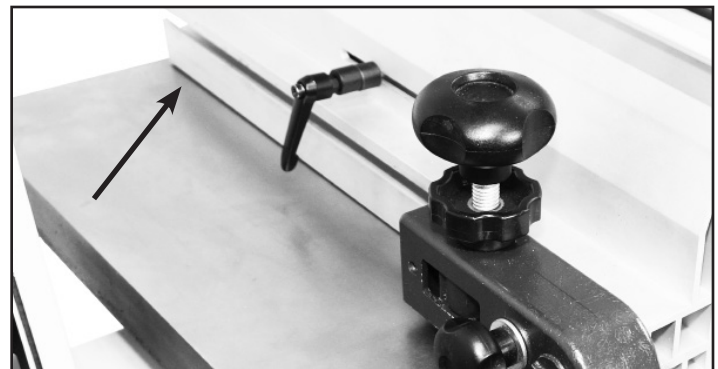

FIGURE 6

ADJUSTING THE FENCE ON THE CARRIER

The fence can be changed from a vertical position to a horizontal position, or from its mounting on the left side of the blade to the right with simple adjustments of the carrier's handles and hardware.

To change the fence from vertical to horizontal:

1. Loosen the side Handle (#7, Fig. 7, A) which holds the rip fence against the Fence Carrier (#9, B).
2. Slide the fence forward to remove it from the carrier's Sliding Block (#11, Fig. 7, C).

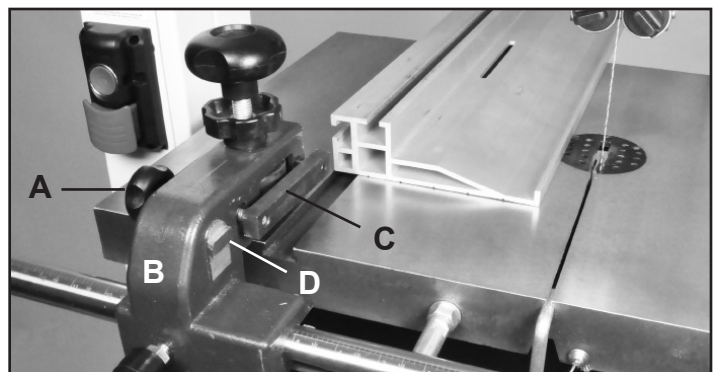

FIGURE 7

CONTINUED ON PAGE 7

ADJUSTMENTS

To change the fence from vertical to horizontal: continued

3. Turn the fence down to its horizontal position and slide it back onto the carrier. The bottom of the fence is slotted to mount on the sliding block, and position itself on the small, raised key on the side of the carrier. Fig. 7, D.

4. Once in place, retighten the side handle to secure the fence in position on the carrier.

5. Check the fence for drift, and make corrections if needed per instructions on page 6.

To change the fence from the left side of the carrier to the right side for using the rip fence to the right of the blade:

1. Loosen the side Handle (#7, Fig. 7, A) which holds the rip fence against the Fence Carrier (#9, B).

2. Slide the fence forward to remove it from the carrier's Sliding Block (#11, C). Move the carrier on the front rail to the right side of the table and blade.

3. Fully unscrew the side handle from the sliding block and reassemble the parts on the opposite, left side of the carrier. Then rotate the fence 180° end-to-end and slide it back onto the carrier. Fig. 9 & 10.

4. Once in place, retighten the side handle to secure the fence in position on the carrier.

5. Check the fence for drift, and make corrections if needed per instructions on page 4 & 5.

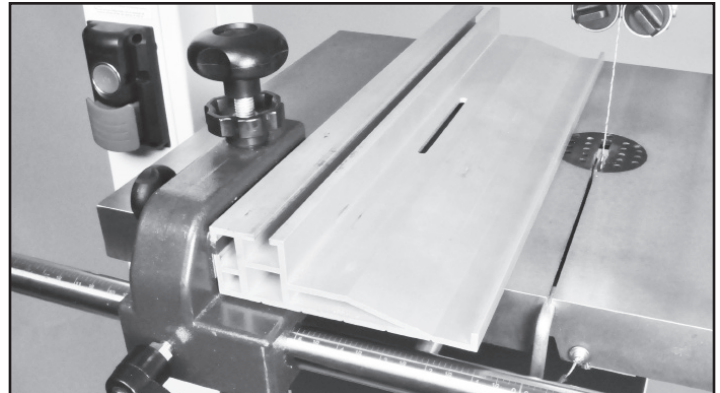

FIGURE 8

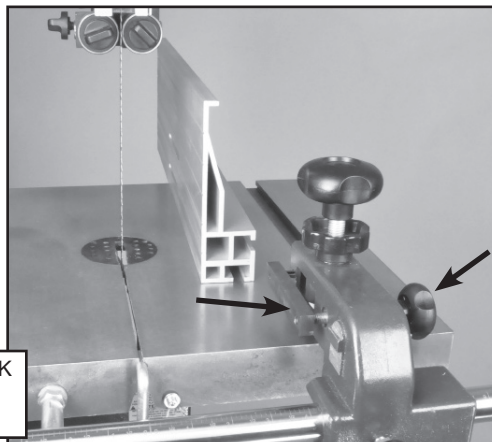

FIGURE 9

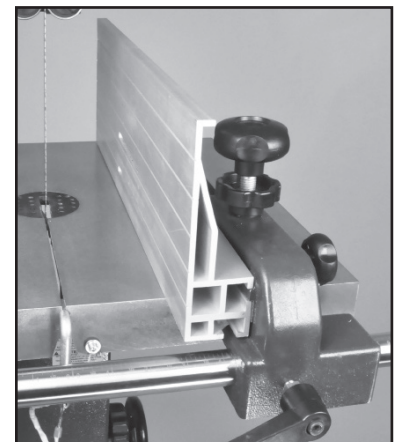

FIGURE 10

RE-SAWING

A re-saw guide bar (#15) is supplied to help correct any blade wandering during certain re-sawing operations.

For re-sawing, attach the re-saw bar to the slot on the fence. Position the re-saw bar so that it is aligned with the front of the blade. Draw a reference line down the workpiece. Use the bar as a pivot point, angling the wood left or right while against the bar, to follow the line through the cut. Fig. 11.

NOTE: The re-saw bar is not needed for all re-saw operations. Proper blade tension and selection, as well as proper guide set up, will allow re-sawing flat stock against the fence without the use of the re-saw bar.

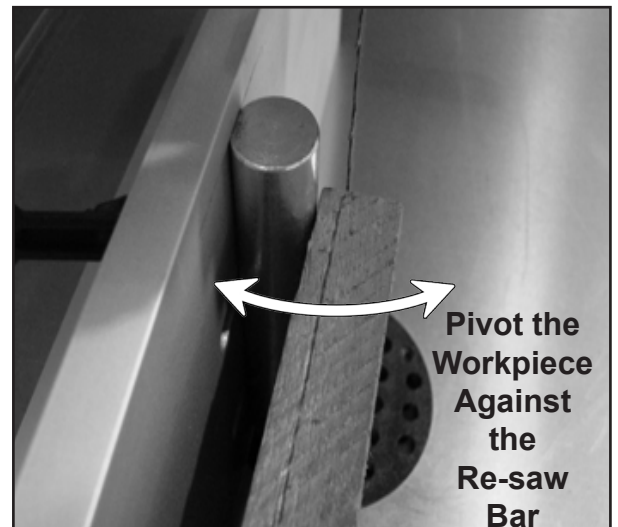

FIGURE 11



10-920

Quick Adjust 6" Tall Rip Fence System

For more information:
16 Progress Road
Billerica, MA 01821

877-884-5167 / 978-528-5380
techsupport@rikontools.com