

18" Professional Bandsaw



Operator's Manual

Record the serial number and date of purchase in your manual for future reference.

Serial Number: _____ Date of purchase: _____

For technical support or parts questions, email techsupport@rikontools.com or call toll free at (877)884-5167

TABLE OF CONTENTS

Specifications.....	2
Safety Instructions	3 - 6
Getting To Know Your Machine	7
Contents of Package	8 - 9
Assembly	10 - 11
Adjustments.....	12 - 18
Operation	19 - 20
Maintenance	21
Wiring Diagram	21
Troubleshooting	22 - 25
Parts Explosions & Parts Lists	26 - 36
Accessories	37
Notes	38
Warranty	39

SPECIFICATIONS

Motor	4 HP, TEFC
Motor Speed (no load).....	3400 RPM
Volts	220 V
Amps, Hertz	16 A, 60 Hz
Blade Length	162" (4115 mm)
Blade Width	1/4" - 1-3/8" (6 - 35 mm)
Blade Speed	4920 ft/min
Table Size	25" x 19" (635 mm x 483 mm)
Table Tilt	Left -5° , Right 45°
Maximum Cutting Width (throat)	17-1/2" (444 mm)
Maximum Cuttng Depth (height)	19" (483 mm)
Table Height	33-1/2" (851 mm)
Fence Height	6" (152 mm)
Fence Length	18-3/4" (476 mm)
Dust Ports (2)	4" Diameter (100 mm)
Overall Size	80" x 39" x 30" (2032 x 991 x 762 mm)
Base Size	29-15/16" x 18-1/8" (760 x 460 mm)
Net Weight	498 lbs (226 kg)

NOTE: The specifications, photographs, drawings and information in this manual represent the current model when the manual was prepared. Changes and improvements may be made at any time, with no obligation on the part of Rikon Power Tools, Inc. to modify previously delivered units. Reasonable care has been taken to ensure that the information in this manual is correct, to provide you with the guidelines for the proper safety, assembly and operation of this machine.

SAFETY INSTRUCTIONS

IMPORTANT! Safety is the single most important consideration in the operation of this equipment. **The following instructions must be followed at all times.** Failure to follow all instructions listed below may result in electric shock, fire, and/or serious personal injury.

There are certain applications for which this tool was designed. We strongly recommend that this tool not be modified and/or used for any other application other than that for which it was designed. If you have any questions about its application, do not use the tool until you have contacted us and we have advised you.

SAFETY SYMBOLS



SAFETY ALERT SYMBOL: Indicates DANGER, WARNING, or CAUTION. This symbol may be used in conjunction with other symbols or pictographs.



Indicates an imminently hazardous situation, which, if not avoided, could result in death or serious injury.



Indicates a potentially hazardous situation, which, if not avoided, could result in death or serious injury.



Indicates a potentially hazardous situation, which, if not avoided, could result in minor or moderate injury.

NOTICE: Shown without Safety Alert Symbol indicates a situation that may result in property damage.

GENERAL SAFETY

KNOW YOUR POWER TOOL. Read the owner's manual carefully. Learn the tool's applications, work capabilities, and its specific potential hazards.

BEFORE USING YOUR MACHINE

To avoid serious injury and damage to the tool, read and follow all of the Safety and Operating Instructions before operating the machine.

1. Some dust created by using power tools contains chemicals known to the State of California to cause cancer, birth defects, or other reproductive harm.

Some examples of these chemicals are:

- Lead from lead-based paints.
- Crystalline silica from bricks, cement, and other masonry products.
- Arsenic and chromium from chemically treated lumber.

Your risk from these exposures varies, depending on how often you do this type of work. To reduce your exposure to these chemicals: work in a well ventilated area and work with approved safety equipment, such as those dust masks that are specially designed to filter out microscopic particles.

2. **READ** the entire Owner's Manual. **LEARN** how to use the tool for its intended applications.

3. **GROUND ALL TOOLS.** If the tool is supplied with a 3 prong plug, it must be plugged into a 3-contact electrical receptacle. The 3rd prong is used to ground the tool and provide protection against accidental electric shock. **DO NOT** remove the 3rd prong. See Grounding Instructions on the following pages.

4. **AVOID A DANGEROUS WORKING ENVIRONMENT.**

DO NOT use electrical tools in a damp environment or expose them to rain.

5. **DO NOT** use electrical tools in the presence of flammable liquids or gasses.

6. **ALWAYS** keep the work area clean, well lit, and organized. **DO NOT** work in an environment with floor surfaces that are slippery from debris, grease, and wax.

7. **KEEP VISITORS AND CHILDREN AWAY. DO NOT** permit people to be in the immediate work area, especially when the electrical tool is operating.

8. **DO NOT FORCE THE TOOL** to perform an operation for which it was not designed. It will do a safer and higher quality job by only performing operations for which the tool was intended.

9. **WEAR PROPER CLOTHING. DO NOT** wear loose clothing, gloves, neckties, or jewelry. These items can get caught in the machine during operations and pull the operator into the moving parts. The user must wear a protective cover on their hair, if the hair is long, to prevent it from contacting any moving parts.

10. **CHILDPROOF THE WORKSHOP AREA** by removing switch keys, unplugging tools from the electrical receptacles, and using padlocks.

11. **ALWAYS UNPLUG THE TOOL FROM THE ELECTRICAL RECEPTACLE** when making adjustments, changing parts or performing any maintenance.

SAFETY INSTRUCTIONS

12. KEEP PROTECTIVE GUARDS IN PLACE AND IN WORKING ORDER.

13. AVOID ACCIDENTAL STARTING. Make sure that the power switch is in the “OFF” position before plugging in the power cord to the electrical receptacle.

14. REMOVE ALL MAINTENANCE TOOLS from the immediate area prior to turning “ON” the machine.

15. USE ONLY RECOMMENDED ACCESSORIES. Use of incorrect or improper accessories could cause serious injury to the operator and cause damage to the tool. If in doubt, check the instruction manual that comes with that particular accessory.

16. NEVER LEAVE A RUNNING TOOL UNATTENDED. Turn the power switch to the “OFF” position. **DO NOT** leave the tool until it has come to a complete stop.

17. DO NOT STAND ON A TOOL. Serious injury could result if the tool tips over, or you accidentally contact the tool.

18. DO NOT store anything above or near the tool where anyone might try to stand on the tool to reach it.

19. MAINTAIN YOUR BALANCE. DO NOT extend yourself over the tool. Wear oil resistant rubber soled shoes. Keep floor clear of debris, grease, and wax.

20. MAINTAIN TOOLS WITH CARE. Always keep tools clean and in good working order. Keep all blades and tool bits sharp, dress grinding wheels and change other abrasive accessories when worn.

21. EACH AND EVERY TIME, CHECK FOR DAMAGED PARTS PRIOR TO USING THE TOOL. Carefully check all guards to see that they operate properly, are not damaged, and perform their intended functions. Check for alignment, binding or breaking of moving parts. A guard or other part that is damaged should be immediately repaired or replaced.

22. DO NOT OPERATE TOOL WHILE TIRED, OR UNDER THE INFLUENCE OF DRUGS, MEDICATION OR ALCOHOL.

23. SECURE ALL WORK. Use clamps or jigs to secure the workpiece. This is safer than attempting to hold the workpiece with your hands.

24. STAY ALERT, WATCH WHAT YOU ARE DOING, AND USE COMMON SENSE WHEN OPERATING A POWER TOOL.

A moment of inattention while operating power tools may result in serious personal injury.

25. ALWAYS WEAR A DUST MASK TO PREVENT INHALING DANGEROUS DUST OR AIRBORNE PARTICLES, including wood dust, crystalline silica dust and asbestos dust. Direct particles away from face and body. Always operate tool in well ventilated area and provide for proper dust removal. Use dust collection system wherever possible. Exposure to the dust may cause serious and permanent respiratory or other injury, including silicosis (a serious lung disease), cancer, and death. Avoid breathing the dust, and avoid prolonged contact with dust. Allowing dust to get into your mouth or eyes, or lay on your skin may promote absorption of harmful material. Always use properly fitting NIOSH/OSHA approved respiratory protection appropriate for the dust exposure, and wash exposed areas with soap and water.

26. USE A PROPER EXTENSION CORD IN GOOD CONDITION. When using an extension cord, be sure to use one heavy enough to carry the current your product will draw. The table on the following page shows the correct size to use depending on cord length and nameplate amperage rating. If in doubt, use the next heavier gauge. The smaller the gauge number, the larger diameter of the extension cord. If in doubt of the proper size of an extension cord, use a shorter and thicker cord. An undersized cord will cause a drop in line voltage resulting in a loss of power and overheating.
USE ONLY A 3-WIRE EXTENSION CORD THAT HAS A 3-PRONG GROUNDING PLUG AND A 3-POLE RECEPTACLE THAT ACCEPTS THE TOOL’S PLUG.

27. ADDITIONAL INFORMATION regarding the safe and proper operation of this product is available from:

- Power Tool Institute
1300 Summer Avenue
Cleveland, OH 44115-2851
www.powertoolinstitute.org
- National Safety Council
1121 Spring Lake Drive
Itasca, IL 60143-3201
www.nsc.org
- American National Standards Institute
25 West 43rd Street, 4th Floor
New York, NY 10036
www.ansi.org
- ANSI 01.1 Safety Requirements for Woodworking Machines and the U.S. Department of Labor regulations
www.osha.gov

28. SAVE THESE INSTRUCTIONS. Refer to them frequently and use them to instruct others.

SAFETY INSTRUCTIONS

ELECTRICAL SAFETY

WARNING

THIS TOOL REQUIRES THE INSTALLATION OF A 220V PLUG (NOT INCLUDED), AND MUST BE GROUNDED WHILE IN USE TO PROTECT THE OPERATOR FROM ELECTRIC SHOCK.

IN THE EVENT OF A MALFUNCTION OR BREAK-DOWN, grounding provides the path of least resistance for electric current and reduces the risk of electric shock. This tool is equipped with an electric cord that has an equipment grounding conductor and requires a grounding plug (not included). The plug **MUST** be plugged into a matching electrical receptacle that is properly installed and grounded in accordance with **ALL** local codes and ordinances.

DO NOT MODIFY ANY PLUG. If it will not fit the electrical receptacle, have the proper electrical receptacle installed by a qualified electrician.

IMPROPER ELECTRICAL CONNECTION of the equipment grounding conductor can result in risk of electric shock. The conductor with the green insulation (with or without yellow stripes) is the equipment grounding conductor. **DO NOT** connect the equipment grounding conductor to a live terminal if repair or replacement of the electric cord or plug is necessary.

CHECK with a qualified electrician or service personnel if you do not completely understand the grounding instructions, or if you are not sure the tool is properly grounded when installing or replacing a plug.

This tool is intended for use on a circuit that has a 220 volt electrical receptacle. **FIGURE A** shows the type of the 220v, 3-wire electrical plug and electrical receptacle that has a grounding conductor that is required.

* Canadian electrical codes require extension cords to be certified SJT type or better.

** The use of an adapter in Canada is not acceptable.

Sample of 220 volt plug required for this machine.



NEMA 6-20P

Figure A

Consult a qualified electrician if the distance of the machine from the electrical panel is greater than 30 feet.

EXTENSION CORDS

WARNING

USE OF AN EXTENSION CORD WITH THIS MACHINE IS NOT RECOMMENDED. FOR BEST POWER AND SAFETY, PLUG THE MACHINE DIRECTLY INTO A DEDICATED GROUNDED ELECTRICAL OUTLET THAT IS WITHIN THE SUPPLIED CORD LENGTH OF THE MACHINE.

IF AN EXTENSION CORD NEEDS TO BE USED, IT SHOULD ONLY BE FOR LIMITED OPERATION OF THE MACHINE. THE EXTENSION CORD SHOULD BE AS SHORT AS POSSIBLE IN LENGTH, AND HAVE A MINIMUM GAUGE SIZE OF 14AWG.

USE ONLY A 3-WIRE EXTENSION CORD THAT HAS THE PROPER TYPE OF A 3-PRONG GROUNDING PLUG THAT MATCHES THE MACHINE'S 4-PRONG PLUG AND ALSO THE 3-POLE RECEPTACLE THAT ACCEPTS THE TOOL'S PLUG.

WARNING

Check extension cords before each use. If damaged replace immediately. Never use a tool with a damaged cord, since touching the damaged area could cause electrical shock, resulting in serious injury.

Use a proper extension cord. Only use cords listed by Underwriters Laboratories (UL). Other extension cords can cause a drop in line voltage, resulting in a loss of power and overheating of tool. When operating a power tool outdoors, use an outdoor extension cord marked "W-A" or "W". These cords are rated for outdoor use and reduce the risk of electric shock.

WARNING

Keep the extension cord clear of the working area. Position the cord so that it will not get caught on lumber, tools or other obstructions while you are working with a power tool.



THIS SYMBOL DESIGNATES THAT THIS TOOL IS LISTED BY THE INTERTEK TESTING SERVICES, TO UNITED STATES AND CANADIAN STANDARDS.

SAFETY INSTRUCTIONS

SPECIFIC SAFETY INSTRUCTIONS FOR BAND SAWS

This machine is intended for the cutting of natural, solid woods, composite materials, plastics and non-ferrous metals. The permissible workpiece dimensions must be observed (see Technical Specification). Any other use not as specified, including modification of the machine or use of parts not tested and approved by the equipment manufacturer, can cause unforeseen damage and invalidate the warranty.

ATTENTION: Use of this band saw still presents risks that cannot be eliminated by the manufacturer. Therefore, the user must be aware that wood working machines are dangerous if not used with care and all safety precautions are adhered to.

1. Do not operate this machine until you have read all of the following instructions.
2. If you are not familiar with the operation of the machine, obtain assistance from a qualified person.
3. Always wear approved, safety protective eye wear and hearing protection when operating this machine.
4. Always wear a dust mask and use adequate dust collection and proper ventilation.
5. Adjust the upper guides about 1/8" to 1/4" above the material being cut.
6. Check for proper blade size and type for the thickness and type of material being cut.
7. Make sure that the blade tension and blade tracking are properly adjusted.
8. Always keep hands and fingers away from the blade.
9. Make "relief" cuts before cutting curves to eliminate blade binding.
10. Always hold material firmly, resting flat on the table and feed it into the blade at a moderate speed.
11. Never attempt to saw stock that does not have a flat surface, unless a suitable support is used.
12. When cutting small work pieces, always use a push stick, holding jig or other device to keep your hands safely away from the blade. Use 'Zero Clearance Inserts' to prevent small pieces from becoming jammed in the table insert or lower blade guides.
13. Always allow the bandsaw blade to stop before removing scrap pieces from the table.
14. Do not remove jammed pieces from the saw until the machine and blade has stopped. Unplug the bandsaw from the power source, and then remove the jammed work piece.
15. Always turn off the machine if the material is to be backed out of an uncompleted cut.
16. Use extra supports (roller stands, saw horses, tables etc.) for any work pieces large enough to tip when not held down to the table top surface.
17. Always turn off and unplug the machine when changing blades or servicing the machine.
18. Release blade tension when the saw will not be used for a long period of time.
19. Remove material or debris from the work area. Keep work area neat and clean.

SAVE THESE INSTRUCTIONS.

Refer to them often.

California Proposition 65 Warning



WARNING

Some dust created by power sanding, sawing, grinding, drilling, and other construction activities contains chemicals known to the State of California to cause cancer and birth defects or other reproductive harm. Your risk from exposure to these chemicals varies, depending on how often you do this type of work. To reduce your exposure, work in a well-ventilated area and with approved safety equipment, such as dust masks that are specially designed to filter out microscopic particles.

For more detailed information about California Proposition 65 log onto www.rikontools.com.

This owner's manual is not a teaching aid. Use of this owner's manual is intended to show assembly, adjustments, and general use.

GETTING TO KNOW YOUR MACHINE

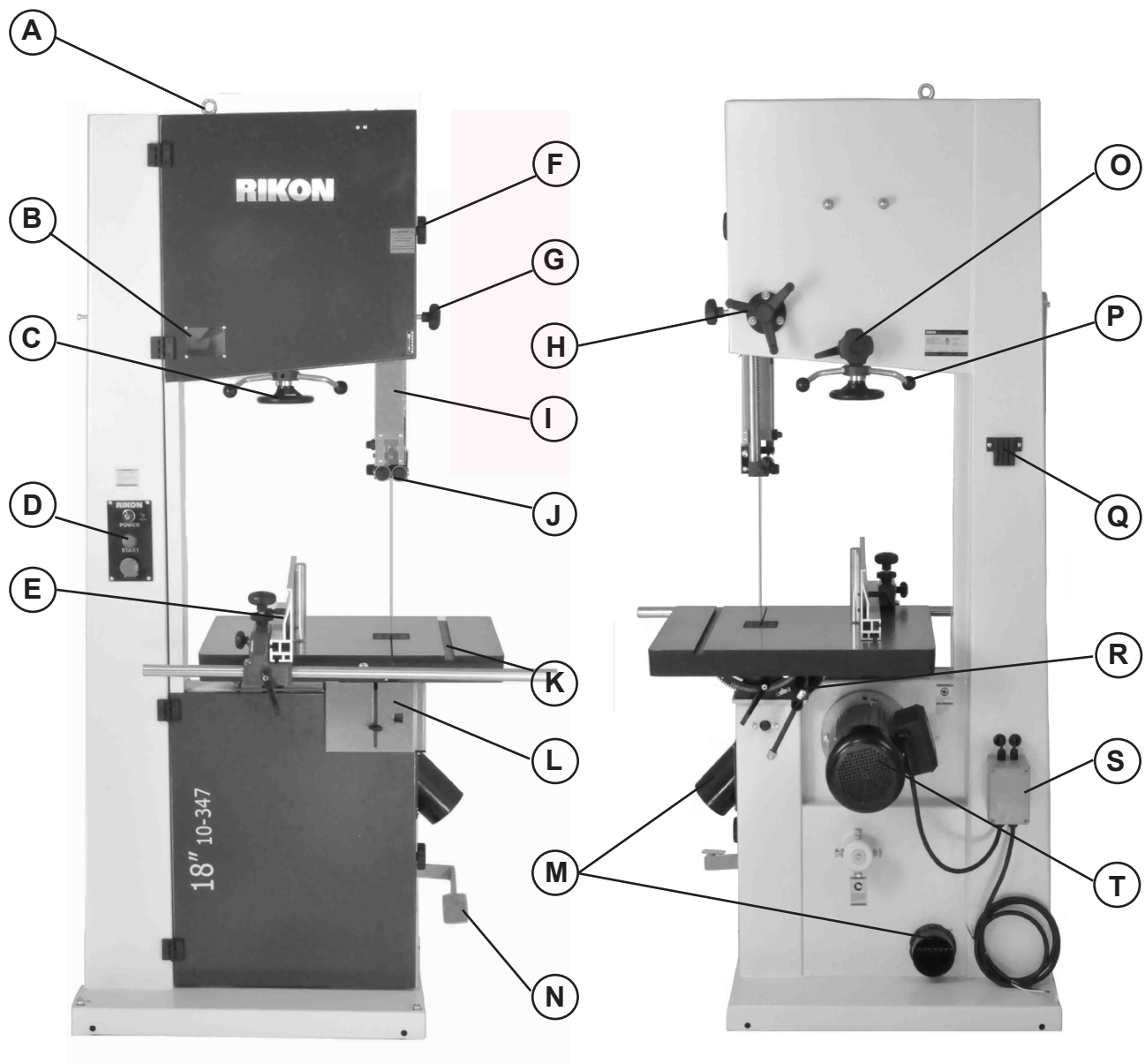

- A. Support Ring
- B. Tension Indicator Window
- C. Blade Tension Hand Wheel
- D. Switch
- E. Rip Fence
- F. Blade Tracking Window
- G. Guide Post Lock Knob
- H. Guide Post Rise/Fall Handle
- I. Hinged Blade Guard
- J. Blade Guides

- K. Work Table
- L. Lower Door Blade Guard
- M. 4" Dust Ports
- N. Foot Brake
- O. Blade Tracking Knob
- P. Quick Release Lever
- Q. Tool Holder
- R. Table Tilt & Lock Knobs
- S. Power Control Box
- T. Motor & Wiring Box

CONTENTS OF PACKAGE

Model 10-347 18" Professional Bandsaw is shipped complete in one crate.

Unpacking, Checking Contents & Clean-up

1. Carefully remove all contents from the shipping carton. Compare the contents with the list of contents to make sure that all of the items are accounted for, before discarding any packing material. Place parts on a protected surface for easy identification and assembly. If any parts are missing or broken, please call RIKON Customer Service (877- 884-5167) as soon as possible for replacements. **DO NOT** turn your machine ON if any of these items are missing. You may cause injury to yourself or damage to the machine.
2. Report any shipping damage to your local distributor. Take photographs for any possible insurance claims.
3. With the help of another person, carefully lift the Bandsaw from the packaging and place it on a level floor.
4. Clean all rust protected surfaces with ordinary house hold type grease or spot remover. Do not use; gasoline, paint thinner, mineral spirits, etc. These may damage painted surfaces.
5. Apply a coat of paste wax to the table to prevent rust. Wipe all parts thoroughly with a clean dry cloth. Be careful, as the pre-installed bandsaw blade has sharp teeth and may cause injury if touched.
6. Set packing material and shipping carton aside. Do not discard until the machine has been set up and is running properly.

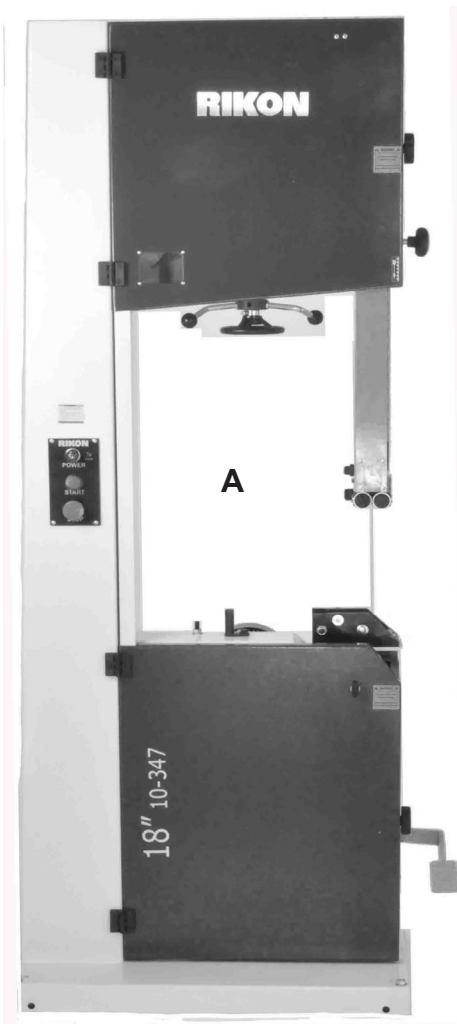
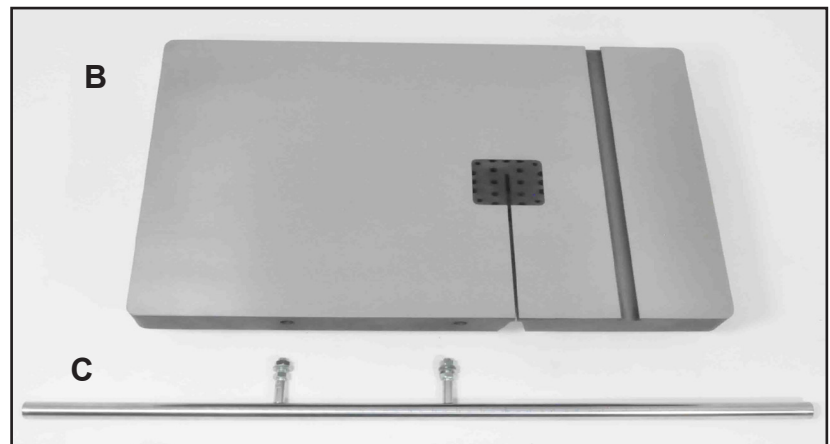
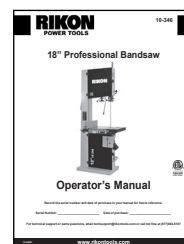

TABLE OF LOOSE PARTS

- A. Bandsaw Frame Assembly
- B. Table with Table Insert
- C. Rip Fence Front Rail and Hardware
- D. Manual with Warranty Card



D



CONTENTS OF PACKAGE

Table & Rip Fence Assembly:

- A. Table
- B. Rip Fence Rail
- C. Fence Rail Hardware:
 - 1. Hex Nut M10 (x4)
 - 2. Flat Washer M10 (x4)
- D. Rip Fence
- E. Rip Fence Carrier
- F. Resaw Bar

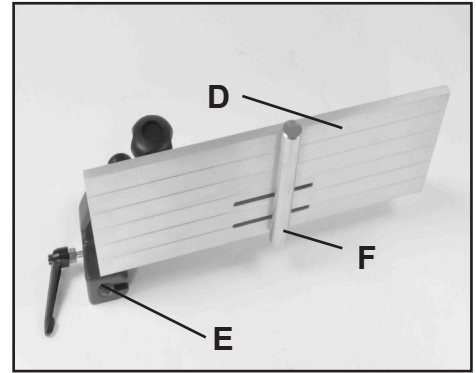
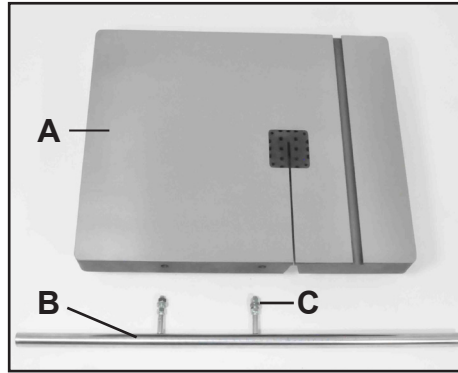

Bandsaw Accessories:

- A. Support Ring
 - B. Hex Screw & Nut for Hanging Push Stick
 - C. Keys for ON/OFF Switch Lock
 - D. Lower Door Blade Guard
 - E. Hardware for Lower Door Blade Guard*
 - F. Push Stick
 - G. Dust Port 4" and Hardware
- * Pre-installed on Lower Door

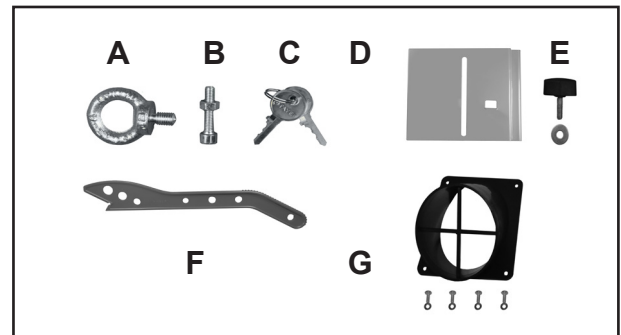

Tools for Assembly & Adjustments:

- A. Hex Wrench 3MM, 4MM, 5MM, 6MM
- B. 10mm Wrench, 13mm Wrench
- C. Offset Wrench for Table Assembly
- D. Table Tilting Wrench

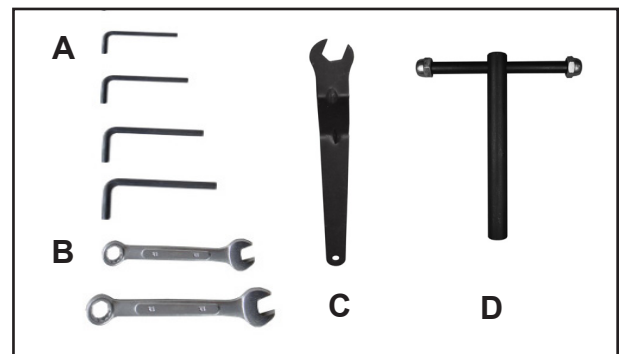

Additional Tool Required - not supplied:

#2 Phillips Screwdriver

INSTALLATION

MOVING & INSTALLING THE BANDSAW

CAUTION The bandsaw is heavy - nearly 500 lbs! It is best to assemble the machine near the area where it will eventually reside. When moving or positioning an assembled bandsaw, DO NOT use the table or upper blade guard assemblies as this may damage the machine. Move the bandsaw by grasping the support column and lower frame which are all welded together for rigidity. The bandsaw can also be moved by laying it down on the back/left side of the column so that the table assembly is not compromised.

1. Carefully remove the machine from the shipping carton. See above instructions on handling the saw.

2. Position the machine on a solid, level foundation that is located in an area that has ample space in front, right side and in back of the bandsaw for cutting large or long material.

For best power and safety, the bandsaw should be plugged directly into a dedicated grounded electrical outlet that is within the supplied cord length of the machine. The use of an extension cord is not recommended.

3. Align the machine so that during use, the material being cut will not face aisles, doorways, or other work areas that bystanders may be in. Do not locate or use the machine in damp or wet conditions.

4. Once in place in your shop, level the machine with spacers, and secure it to the floor with lag screws (not supplied) using the 4 holes in the saw's base.

ASSEMBLY

⚠ WARNING THE MACHINE MUST NOT BE PLUGGED IN AND THE POWER SWITCH MUST BE IN THE OFF POSITION UNTIL ASSEMBLY IS COMPLETE.

INSTALLING THE WORK TABLE

⚠ CAUTION The Work Table is extremely heavy. It may require two other individuals to assist with the installation.

NOTE: The upper and lower bandwheel doors must remain closed during table installation.

The guide shaft (A-Fig.1) and table locking hardware (B-Fig.1) were installed on the lower trunnion (C-Fig.1) during saw assembly. These need to be removed prior to table installation.

NOTE: The bandsaw blade is installed at the factory. It is recommended to remove the blade prior to installing the table. See “CHANGING THE SAW BLADE” on page 14.

With the guide shaft, table locking hardware and blade removed carefully lift the table (team lift) and lower the upper trunnion (installed at factory) (A-Fig.2) onto the lower trunnion. Ensure that the gear teeth on the upper trunnion (B-Fig.2) engage the gear on the lower trunnion (A-Fig.3).

Install the guide shaft and table locking hardware from the left side of the upper trunnion (user cutting position) through the lower trunnion and out the right side of the upper trunnion.

NOTE: The table locking handle (B-Fig.3) is to be installed on the right side of the upper trunnion in the lower hole below the guide shaft position (C-Fig.3)

NOTE: Before finally secured in position, the table can be slightly moved, left and right. Check to make sure that the table's miter gauge slot is parallel to the side of the saw blade. This will provide a true cut when ripping stock. Set a thin metal ruler against the side of the saw blade. Make sure that it is not touching the saw's teeth, which can angle the ruler. Measure the distance from one end of the ruler to the miter gauge slot. FIG. 4. Then measure the same distance from the other end of the ruler to the miter gauge slot. Compare these two measurements and angle the table as necessary until the distances are the same.

Once the table is aligned parallel to blade, tighten all four of the installed bolts to secure the table in place.

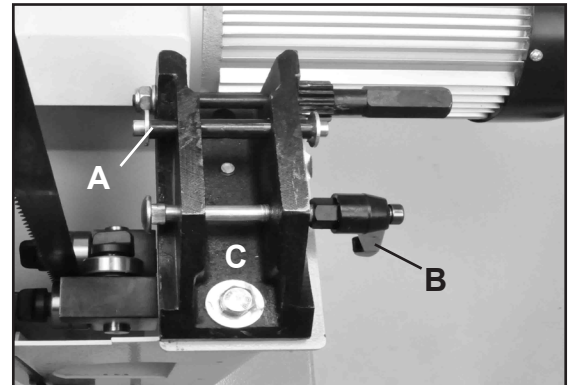

Figure 1

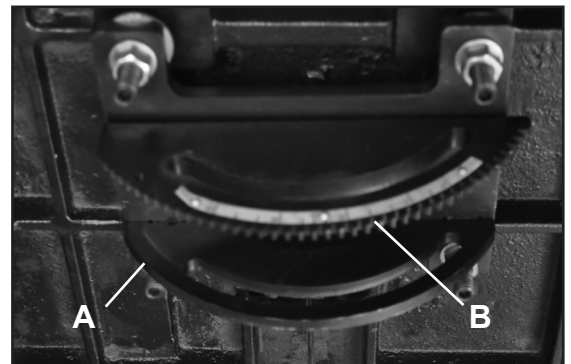

Figure 2

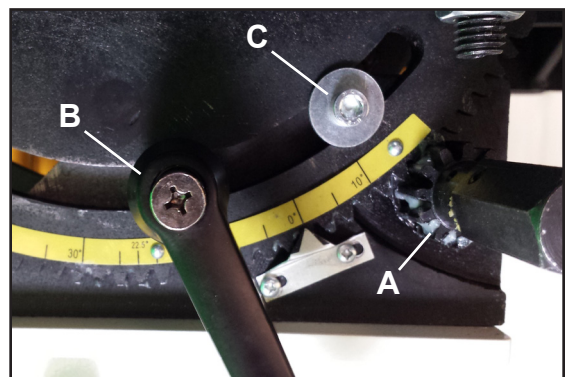

Figure 3

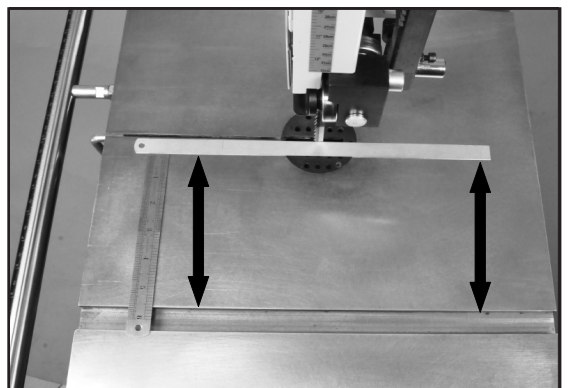

Figure 4

ASSEMBLY / ADJUSTMENTS

RIP FENCE ASSEMBLY

Note: Part numbers referred below can be found on page 36 of this manual.

1. Mount the fence Guide Rail (#12F) onto the front table edge with the two fence bar Nuts and Washers (#14F, 5F) Fig. 5. Position the bar so that it is parallel with the table surface, and equal distance out from the front edge of the table when measured at both left and right front edges of the table.
2. Slide the Fence Carrier Assembly (#9F) onto the fence's guide rail. Fig. 6.
3. Slide the Rip Fence (#18F) onto the fence carrier, and lock it in place by tightening the fence lock Knob (#7F) which is located on the carrier, opposite side to the fence. Fig. 6, A.
4. With the front Locking Handle (#10F, Fig. 6,B) secure the fence on the rail so that it does not move during the rest of the assembly process. Final adjustments to the fence are covered on pages 16 to 18. Information on the re-saw bar is on page 20.

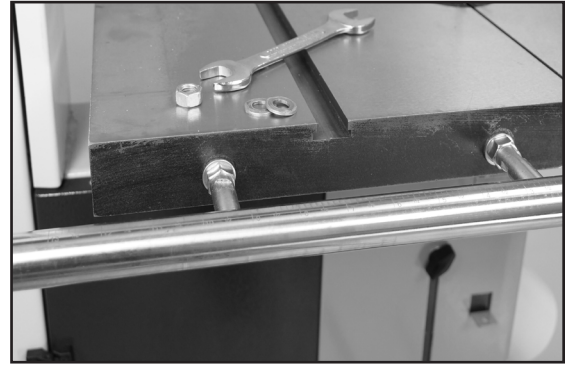

Figure 5

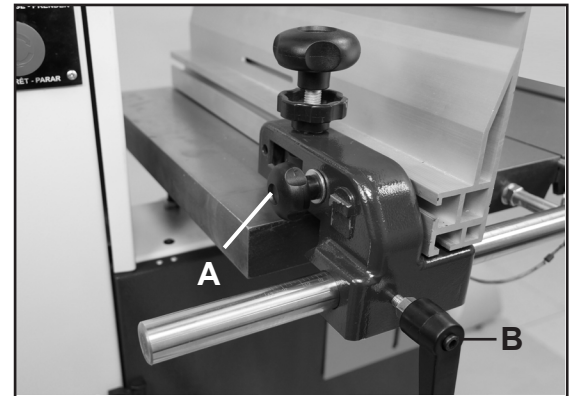

Figure 6

INSTALLING THE 4" DUST PORT

Note: Part numbers referred below can be found on page 26 of this manual.

The 4" dust port under the table is installed on the frame above the lower door knob. Locate four 4mm pan head screws and four 4mm flat washers from the hardware pack. Using a Phillips-head screw driver install the screws through the dust port flange into pre-threaded holes in the frame. See Figure 5.



Figure 7

INSTALLING THE LOWER DOOR BLADE GUARD

Hardware for the lower door blade guard has been pre-installed at the factory. Locate the plastic wing nut part #16A (refer to parts explosion on page 26 of this manual) and washer on the lower door and remove. Place the lower door blade guard part #18A over the threaded hole in the door in alignment with the long adjustment slot. Install the plastic wing nut and washer through the long adjustment slot and thread into the door. See Figure 8. Adjust as needed to cover the blade under the table.

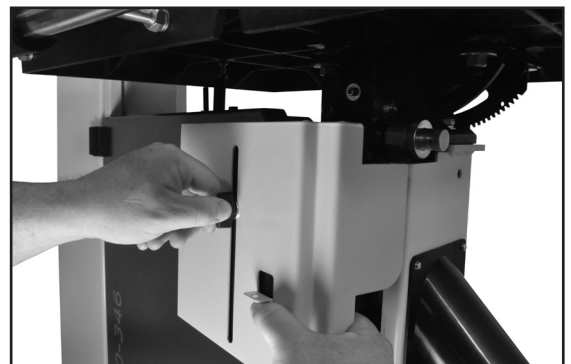

Figure 8

ASSEMBLY / ADJUSTMENTS

SETTING THE TABLE SQUARE TO SAW BLADE

The table may be set at 90° to the saw blade sides by adjusting the table stop screw (A-Fig.9) under the table. The table stop screw rests on the top of the quick release adjustment stop (B-Fig.9). First loosen the locking nut (C-Fig.9) and set a square between the blade and the work table. Adjust the table stop screw (A-Fig.9) until the table and blade are set at 90°. Retighten the locking nut (A-Fig.9) making sure that the setting is maintained.

The table may also be set at 90° to the back of the saw blade by adjusting the table mounting bolts. One of the four table mounting bolts shown in Figure 10. With the Offset Wrench provided slightly loosen part #9C mounting bolt (refer to parts explosion on page 30 of this manual).

Using the 6mm “L” wrench provided, turn the trunnion micro adjusting screw #8C, as needed, to achieve desired setting. Turning the screw clockwise will raise the trunnion; counterclockwise will lower. Check table for 90° and tighten part #3C to the top of the upper trunnion to retain the desired setting. Finish by tightening part #9C.

TILTING THE TABLE

Loosen the locking handle (A-Fig.11) on the table trunnion. Install the Table Tilting Wrench (B-Fig.11) onto the Gear Shaft (C-Fig.11). Turn the Table Tilting Wrench to adjust the table to the desired angle. Use the angle indicator scale on the trunnion bracket to find the desired angle. Retighten the lock handle to secure the table.

TRACKING THE BANDSAW BLADE

⚠ WARNING A blade is provided and installed at the factory. It is recommended to check the blade tracking prior to use. Unplug the bandsaw. Make sure the upper and lower blade guides are adjusted away from the blade and the tension scale is set to correspond to the width of the blade you are using.

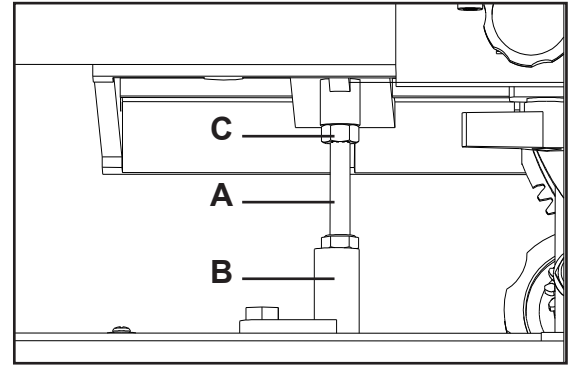

Figure 9

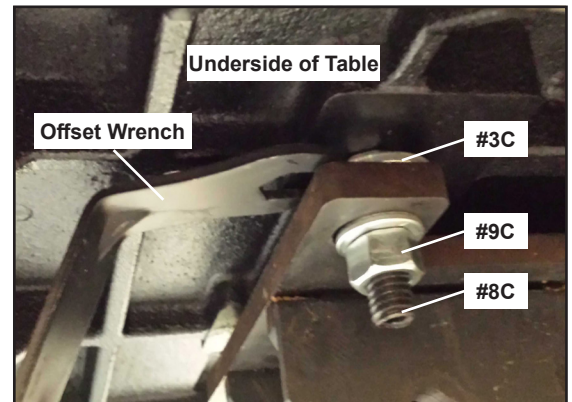

Figure 10



Figure 11

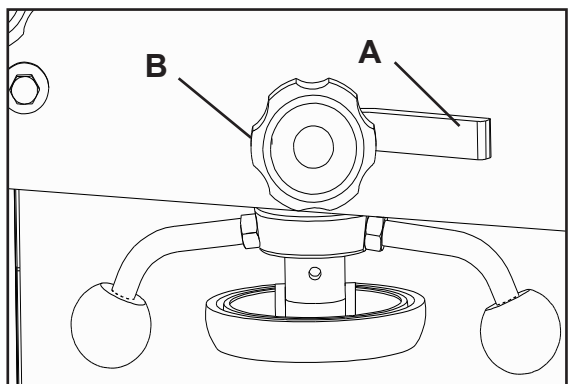

Figure 12

Continued on page 13

ADJUSTMENTS

TRACKING THE BANDSAW BLADE Cont.

Open both doors. Loosen the lock lever (A-Fig.12) by turning it counter clockwise and turn the blade tracking knob (B-Fig.12) clockwise/counterclockwise while turning the upper wheel by hand at least three rotations or until the blade tracks centered on the wheel. Finally, tighten the lock lever and close the doors.

ADJUSTING THE BLADE TENSION

The 10-347 has a Quick Release blade function which allows for fast blade changing and tensioning. The Quick Release Lever is shown in Figure 13.

To loosen the tension of the blade, turn the blade tension hand wheel, or lever, (A-Fig.14) counter clockwise. To tighten the tension of the blade, turn the blade tension hand wheel clockwise. Tension the blade until the tension readings correspond to the width of blade you are using by viewing through the tension indicator window (B-Fig.14).

Note: The blade tension scale may read differently due to cut specifications of the blade manufacturer. It might be necessary to increase/decrease tension up/down one size on blade tension scale to achieve proper blade tension.

CAUTION Always tension the blade with the quick release lever in the “On” position. Failure to do so could result in lack of blade tension or tension failure.

BLADE TENSION INDICATOR ADJUSTMENT

The Blade Tension Indicator arrow should be checked and adjusted the first time the saw is set up and run, and whenever a new blade is installed. The blade tension indicator can also be adjusted for blades made from thicker steel, or cut over/under in length by different manufacturers.

With moderate tension on the blade loosen the two adjusting screws with a Phillips-head screw driver (A-Fig.15). Adjust the blade indicator up/down as needed (B-Fig.15) and re-tighten the two adjusting screws.

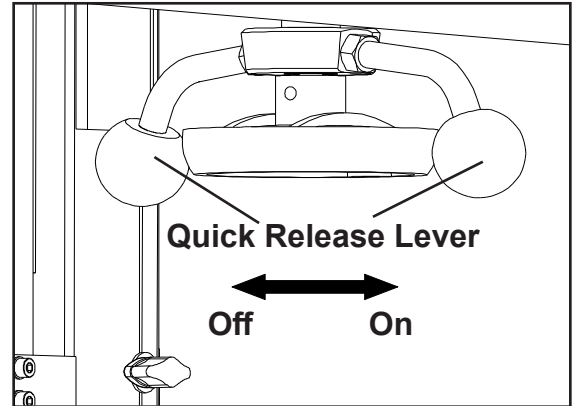

Figure 13

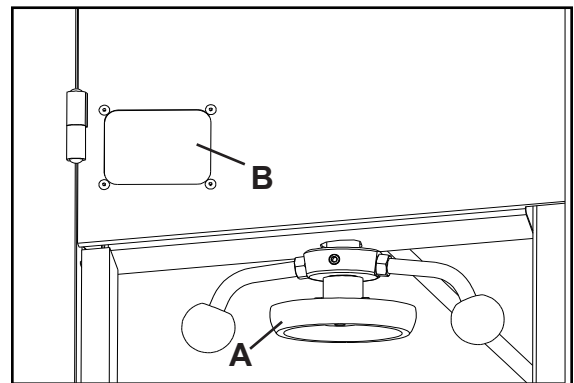

Figure 14

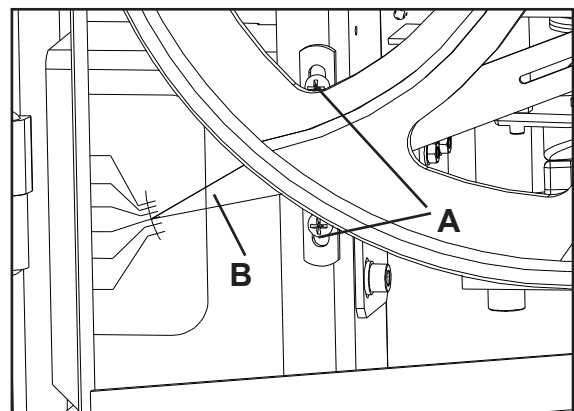

Figure 15

ADJUSTMENTS

CHANGING THE BANDSAW BLADE

⚠ WARNING Unplug the machine from the electrical supply. This ensures that the Bandsaw will not accidentally turn on if the ON/OFF switch is bumped.

Wear gloves for protection.

- a) Open the top and bottom wheel doors by turning the door locking knobs. (A-Fig.16)
- b) Release the blade tension by moving the quick release lever (Fig.17) from right to left. Open the hinged door on the blade guard by loosening the wing screw (A-Fig.18).
- c) Remove the saw blade by feeding it through the slot in the table, upper and lower blade guides and the slot in the spine of the machine. Be careful not to cut yourself.
- d) When installing the new blade, ensure the blade teeth are pointing downwards and towards you at the position where the blade passes through the table.
- e) Center the blade on both wheels.
- f) Re-tension the new blade by moving the quick release lever (Fig.17) left to right and check the blade tracking. With your hand, slowly spin the upper wheel clockwise three times. The blade should run in the center of both wheels. Refer to "Tracking the Saw Blade" on pages 12 and 13 for more details.
- g) Set the blade guides as described in the section "Adjusting the Blade Guides" on page 15.
- h) Close the hinged door on the blade guard and tighten the wing screw (A-Fig.18).
- i) Close and lock both the wheel doors (A-Fig.19) before reconnecting the power supply.

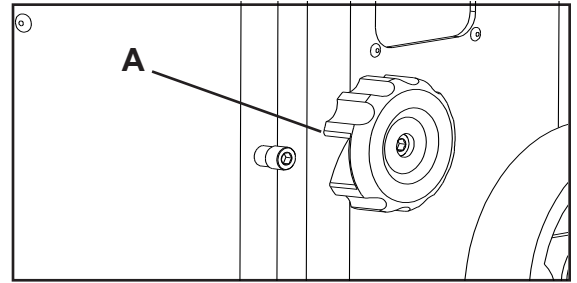

Figure 16

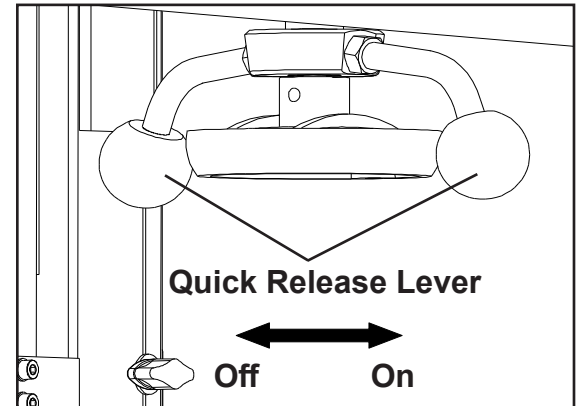

Figure 17

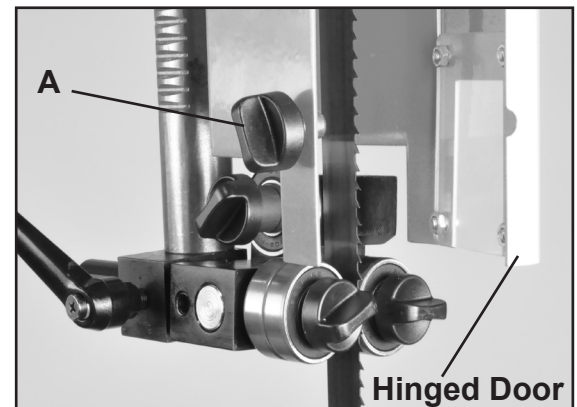

Figure 18

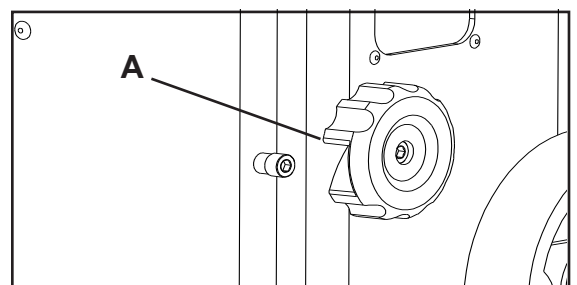

Figure 19

ADJUSTMENTS

ADJUSTING THE SPRING LOADED BLADE GUIDES

NOTE: Blade Guard removed for photo purposes

WARNING Unplug the machine from the electrical supply. This ensures that the Bandsaw will not accidentally turn on if the ON/OFF switch is bumped.

Upper Guides: To adjust the upper blade guides, first position the roller guides relative to the blade by loosening the Lock Handle (A-Fig.20) and sliding the guide assembly until the side roller guides are approximately 1/16" behind the gullet of the blade, then re-tighten the Lock Handle (A-Fig.20).

Next, set the roller guides to within 1/32" of the blade by releasing the lock Lock Handles (B-Fig.20) and push the ends of the Guide Shafts (C-Fig.20) towards the blade. Do not set the guides too close, as this will adversely affect the life of the blade. When the correct adjustment is reached, lock the guides in position by tightening the Lock Handles (B-Fig.20). Finally, follow the same steps above to position the rear thrust guide (D-Fig.20).

Lower Guides: To adjust the lower blade guides, first loosen the Lock Handle (A-Fig.21). Move the lower guide support assembly to allow the side roller guides to be approximately 1/16" behind the gullets of the blade, and re-tighten the Lock Handle. Next set the roller guides to within 1/32" of the blade by releasing the Lock Handles (A-Fig.22) and push the ends of the Guide Shafts (B-Fig.22) towards the blade. Do not set the guides too close, as this will adversely affect the life of the blade. Finally, follow the same steps above to position the rear thrust guide (C-Fig.22).

Make sure the doors are closed, turn the bandsaw on and inspect that the upper, lower and thrust guides are not turning. All guides should not turn unless pressure from workpiece is applied to the blade. If guides are turning under no pressure, repeat the steps above to correctly adjust the blade guides.

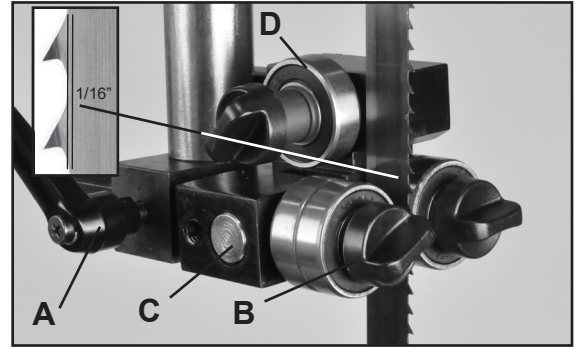

Figure 20

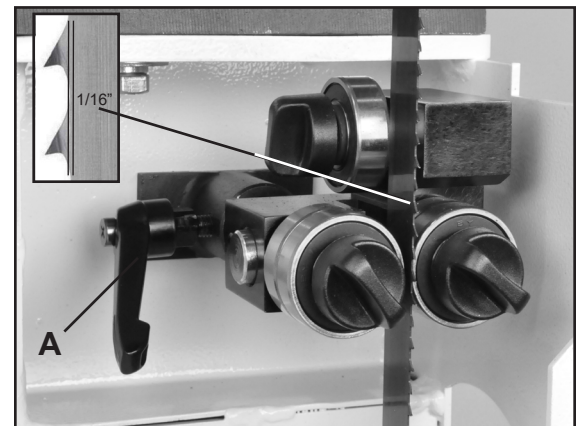

Figure 21

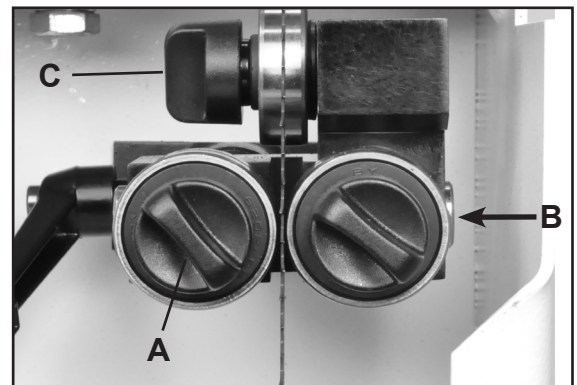

Figure 22

ADJUSTMENTS

ADJUSTING THE CUTTING HEIGHT

Loosen the guidepost lock knob (A-Fig.23) and turn the guidepost handwheel (B-Fig.23) to raise or lower the guide post/upper blade guide assembly to the desired height. Then tighten the guidepost lock knob.

Note: The bottom edge of the guides should be approximately 1/4" above the top surface of the work piece. (Fig.24)

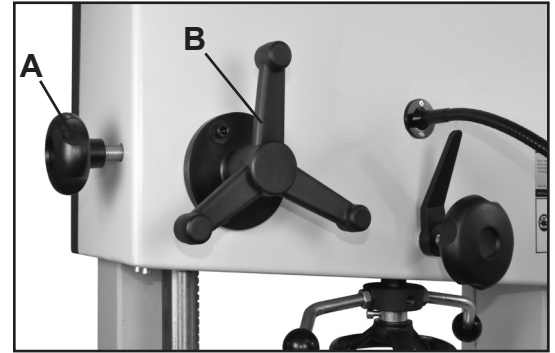

Figure 23

ADJUSTING THE RIP FENCE FOR DRIFT

The 10-347 Bandsaw features an innovative fence system that will easily adjust to eliminate 'drift', and bring the fence back to being parallel to the blade. Plus, it allows quick changing of the fence from a vertical to horizontal position, or for use to the left or right of the blade. To adjust the fence for drift:

1. Loosen the side Handle (#7F, Fig. 25, A) which holds the rip fence against the Fence Carrier (#9F, B).
2. Loosen the Locking Knob (#2F, Fig. 25, C).
3. Turn the top Adjusting Handle (#1F, D) to position the fence left or right as needed to align it parallel to the blade and miter saw slots in the table. The handle turns a Cam (#4F, E) that presses against the fence and pivots it as needed.
4. Once the fence is set, tighten the Handle and Knob that were loosened in steps 1 and 2.

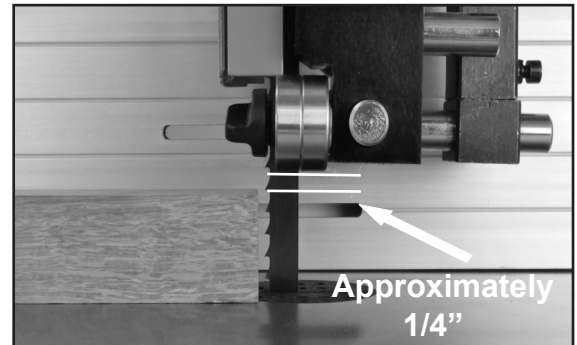

Figure 24

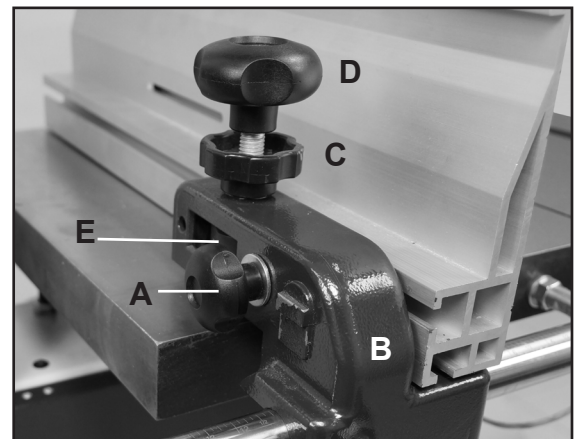

Figure 25

ADJUSTING THE FENCE 90° TO THE TABLE

Check that the fence is 90 degrees to the table using a suitable square. If adjustments are required, raise or lower either side of the fence's Guide Rail until the fence body is 90 degree to the table. Once set at 90 degrees, fully tighten the fence bar nuts. FIG. 24.

See page 11 for the guide rail installation process.

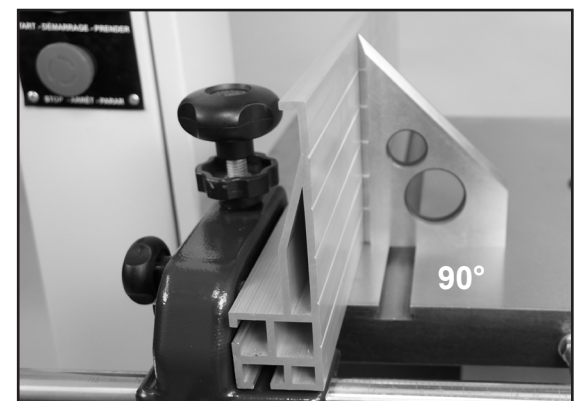

Figure 26

ADJUSTMENTS

ADJUSTING THE FENCE TO THE TABLE

Check that the fence is lying flat, or parallel to the table surface. The gap between the table and the bottom of the fence should be equal along the whole length of the fence. If a slight adjustment is necessary, the Nylon Plate (#25F), that is located at the front base of the Fence Carrier (#9F), can be turned to raise or lower the fence distance over the table. Fig. 27.

If there is a sizeable gap, refer to page 11 for the mounting and re-positioning of the front fence rail.

ADJUSTING THE FENCE ON THE CARRIER

The fence can be changed from a vertical position to a horizontal position, or from its mounting on the left side of the blade to the right with simple adjustments of the carrier's handles and hardware.

To change the fence from vertical to horizontal:

1. Loosen the side Handle (#7F, Fig. 28, A) which holds the rip fence against the Fence Carrier (#9F, B).
2. Slide the fence forward to remove it from the carrier's Sliding Block (#11F, Fig. 28, C).
3. Turn the fence down to its horizontal position and slide it back onto the carrier. The bottom of the fence is slotted to mount on the sliding block, and position itself on the small, raised key (Fig. 28, D) on the side of the carrier. Fig. 29.
4. Once in place, retighten the side handle to secure the fence in position on the carrier.
5. Check the fence for drift, and make corrections if needed per instructions on page 16.

To change the fence from the left side of the carrier to the right side of the carrier for using the rip fence to the right of the blade:

1. Loosen the side Handle (#7F, Fig. 28, A) which holds the rip fence against the Fence Carrier (#9F, B).
2. Slide the fence forward to remove it from the carrier's Sliding Block (#11F, C). Move the carrier on the front rail to the right side of the table and blade.
3. Fully unscrew the side handle from the sliding block and reassemble the parts on the opposite, left

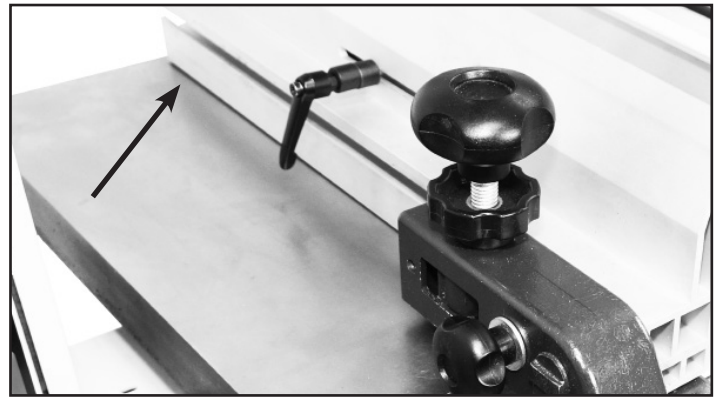

Figure 27

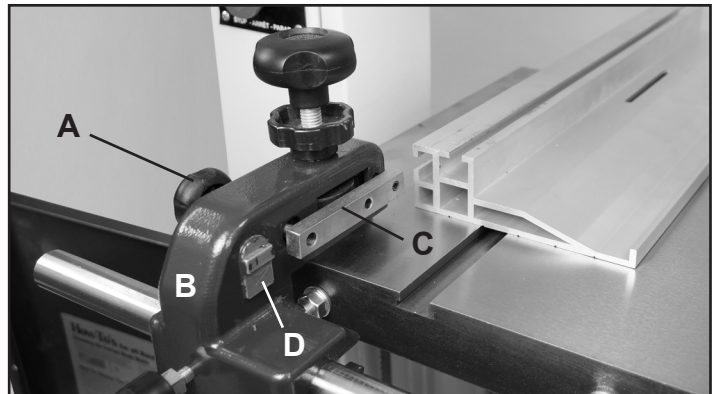

Figure 28



Figure 29

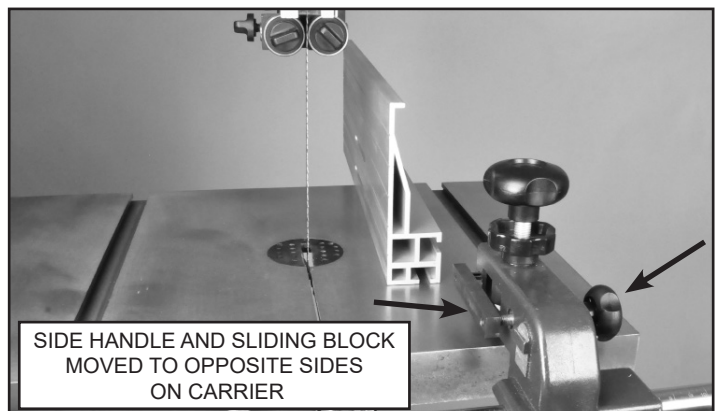

Figure 30

ADJUSTMENTS

side of the carrier. Then rotate the fence 180° end-to-end and slide it back onto the carrier. Fig. 30 & 31.

4. Once in place, retighten the side handle to secure the fence in position on the carrier. Fig. 31.

5. Check the fence for drift, and make corrections if needed per instructions on page 18.

⚠ WARNING THE MACHINE MUST NOT BE PLUGGED IN AND THE POWER SWITCH MUST BE IN THE OFF POSITION UNTIL ALL ADJUSTMENTS ARE COMPLETE.

ADJUSTING THE DRIVE BELT TENSION

Check the Drive Belt (#87A, FIG. 32, A) tension with thumb pressure. The drive belt should not give more than 3/8" TO 1/2" in the center (Fig. 33). DO NOT over tension the belt as this can put excessive, damaging pressure on the belt, pulleys and motor.

To adjust the tension:

1. Loosen the two Hex Bolts (Fig. 32, B) that secure the motor to the frame.
2. Loosen the Hex Nut on the top of the Motor Pulling Rod (Fig. 32, C). The motor should now be loose to move downward for adjusting the belt.
3. For *less tension* on the drive belt, push the motor downward.
4. For *more tension* on the drive belt, lift the motor upwards. NOTE: There is a second hex nut on the motor pulling rod that is located *under* the frame. This second hex nut (Fig. 32, C) must be loosened to allow the motor to be lifted upwards.
5. When the belt tension is correct, tighten all the motor mounting nuts from steps 1, 2 and 4 above.

SEE PAGE 23 FOR INSTRUCTIONS ON CHANGING THE DRIVE BELT.

LEVELING THE TABLE INSERT

The table insert has an innovative, built-in micro adjustment feature to use if the insert sits too high or too low in the table seat. If the insert is resting *above* the table, turn the hex screws counter-clockwise to lower the insert. If the insert is sitting *below* the table surface, turn the hex screws clockwise to raise the insert level with the table surface. Fig. 34.

CAUTION: Having the insert below the table surface could cause the workpiece to get stuck on the lip of the table seat behind the blade, stopping your cut.

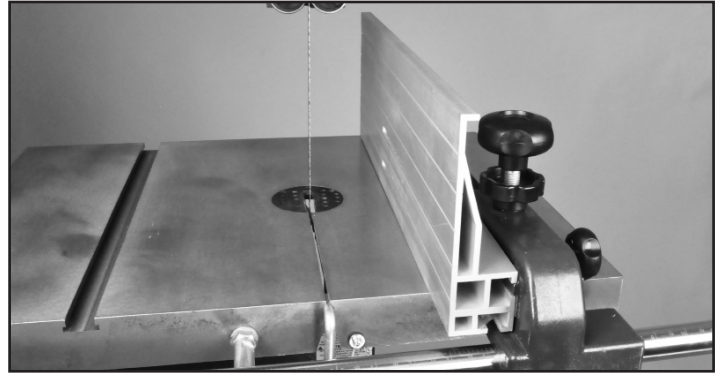

Figure 31

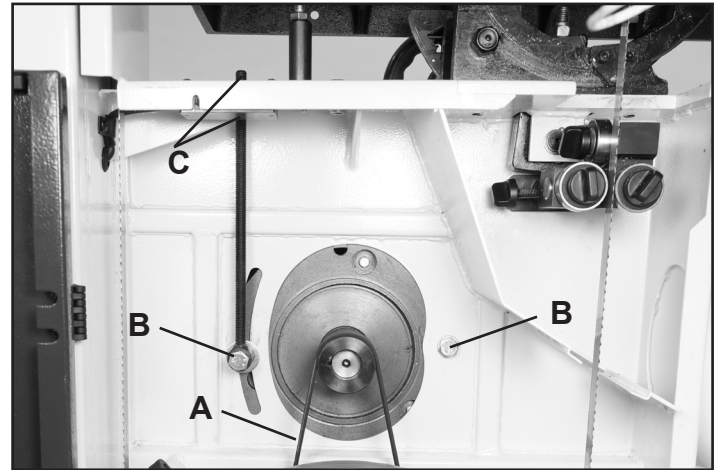

Figure 32

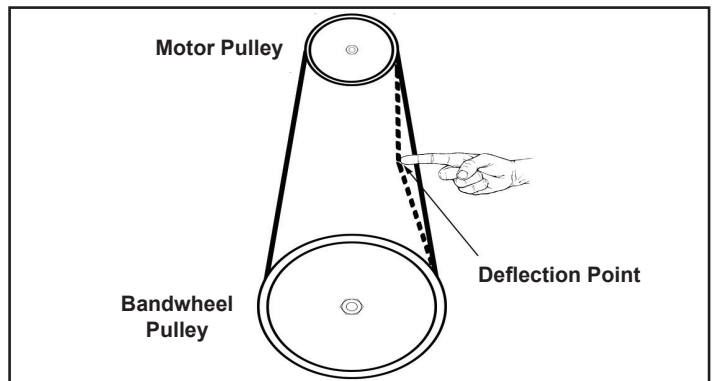

Figure 33

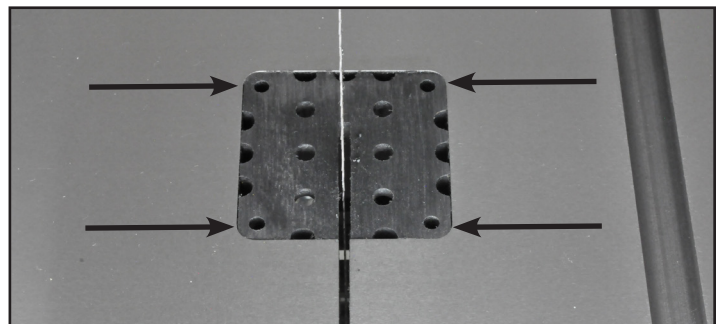

Figure 34

OPERATION

BASIC OPERATION

The blade cuts on a continuous down-stroke. Never start the saw with the workpiece in contact with the saw blade.

With both hands, firmly hold the workpiece down on the table, and feed it slowly towards the blade, putting only light pressure on it, and keeping your hands away from the blade.

Keep your hands/fingers away from the blade. Use a push stick whenever working close to the blade.

For best results the blade must be sharp. A dull blade will not cut correctly, especially when straight cutting, and causes excess pressure to be applied on the rear guide bearings.

Select the right blade for the job, depending on the thickness of the wood and the cut to be made. The thinner and harder the wood, the finer the teeth of the blade should be. Use a fine tooth blade for cutting sharp curves.

The machine is especially suited for cutting curves, but will also make straight cuts. When cutting, follow the design marked out by pushing and turning the workpiece evenly into the blade.

Do not attempt to turn the workpiece without pushing it, as this may cause the workpiece to get stuck, or bend the blade. For straight cuts, use the fence provided to feed the workpiece along the blade slowly and in a straight line. Use a miter gauge for cross-cut or angle cutting.

ON/OFF SWITCH CONTROL STATION

The 10-347 has a key-on safety feature that will lock out unauthorized users such as students, coworkers or employees not trained or qualified to use the bandsaw.

To operate the saw, turn the key (A-Fig. 35) to the right to activate the control station. A green light will illuminate (B-Fig. 35) showing that the saw is ready for use. Press the green "START" button (C-Fig. 35) to turn the saw on. Once work is finished, press the "STOP" button to turn the saw off.

Note: If working with large pieces and not able to reach the "STOP" button simply press the foot brake. There is a switch built into the foot break assembly that will turn the saw off.

FOOT BRAKE

The foot brake (A-Fig. 36), when depressed will slow the blade to a stop, and will also shut off the bandsaw, simultaneously. This is an added safety feature that allows you to handle large workpieces without having to reach back to the switch control station to the main "STOP" button. The foot brake's lever, when depressed, pivots the break pad (B-Fig. 36) against the break disc on the motor pulley.



Figure 35

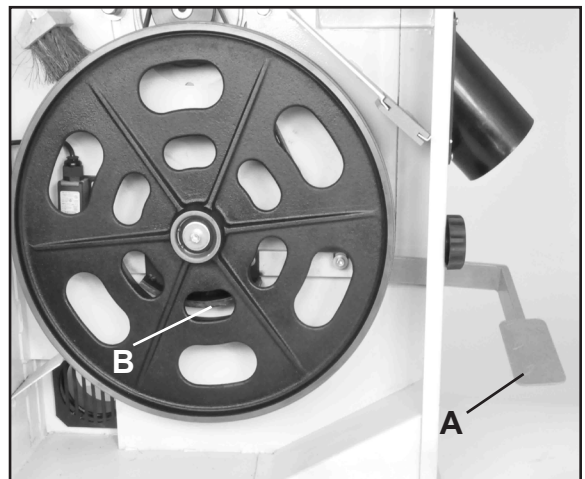

Figure 36

OPERATION

RE-SAWING

A re-saw guide bar is supplied to help correct any blade wandering during certain re-sawing operations.

For re-sawing, attach the re-saw bar to the slot on the fence. Position the re-saw bar so that it is aligned with the front of the blade. Draw a reference line down the workpiece. Use the bar as a pivot point, angling the wood left or right while against the bar, to follow the line through the cut. Figure 37.

Note: The re-saw bar is not needed for all re-saw operations. Proper blade tension and selection, as well as proper guide set up, will allow re-sawing flat stock against the fence without the use of the re-saw bar.

QUICK RELEASE BLADE TENSION LEVER

The tension lever that operates the quick release blade function has two of the most innovative features on the 10-347. (Fig. 38) One feature allows the blade tension to be released from back or front of the saw.

The other feature disables the saw from operating if the quick release lever is not engaged with no tension on the blade. This prevents accidental starting while the tension lever is off and will eliminate the possibility of damaging a blade or the saw.

DOOR SAFETY SWITCH

Both the upper and lower blade wheel doors are equipped with a safety switch that will shut the saw off when opened. (Fig.39) The saw will not operate until the blade wheel doors are closed. If the doors are opened while the saw is running, power to the motor will be cut off. The only way to restart the saw is to make sure both band wheel doors are closed before pressing the "START" button.

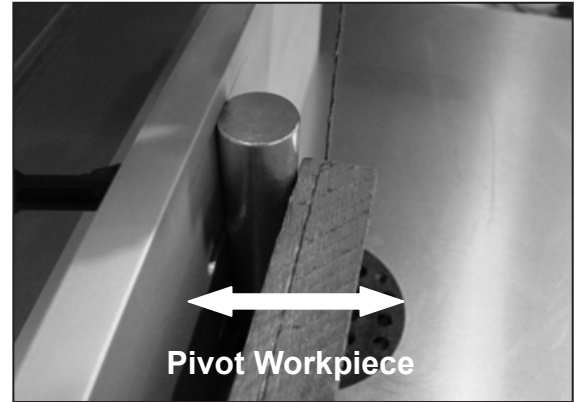

Figure 37



Figure 38



Figure 39

MAINTENANCE

⚠ CAUTION BEFORE CLEANING OR CARRYING OUT MAINTENANCE WORK, DISCONNECT THE MACHINE FROM THE POWER SOURCE (WALL SOCKET). NEVER USE WATER OR OTHER LIQUIDS TO CLEAN THE MACHINE. USE A BENCH BRUSH. DO NOT USE COMPRESSED AIR NEAR BEARINGS. REGULAR MAINTENANCE OF THE MACHINE WILL PREVENT UNNECESSARY PROBLEMS.

1. Keep the table clean to ensure accurate cutting.
2. Keep the outside of the machine clean to ensure accurate operation of all moving parts and prevent excessive wear.
3. Keep the ventilation slots of the motor clean to prevent it from overheating.
4. Keep the inside of the machine (near the saw blade, etc.) clean to prevent accumulation of dust. Use dust collection, if possible.
5. To prolong the life of the blade, when the bandsaw is not in use for extended periods, release the blade tension. Before reusing the bandsaw, ensure that the blade is re-tensioned and tracking is checked.
6. Keep guide bearings free of dust, clean frequently.

WIRING DIAGRAM

⚠ WARNING This machine must be grounded. Replacement of the power supply cable should only be done by a qualified electrician.

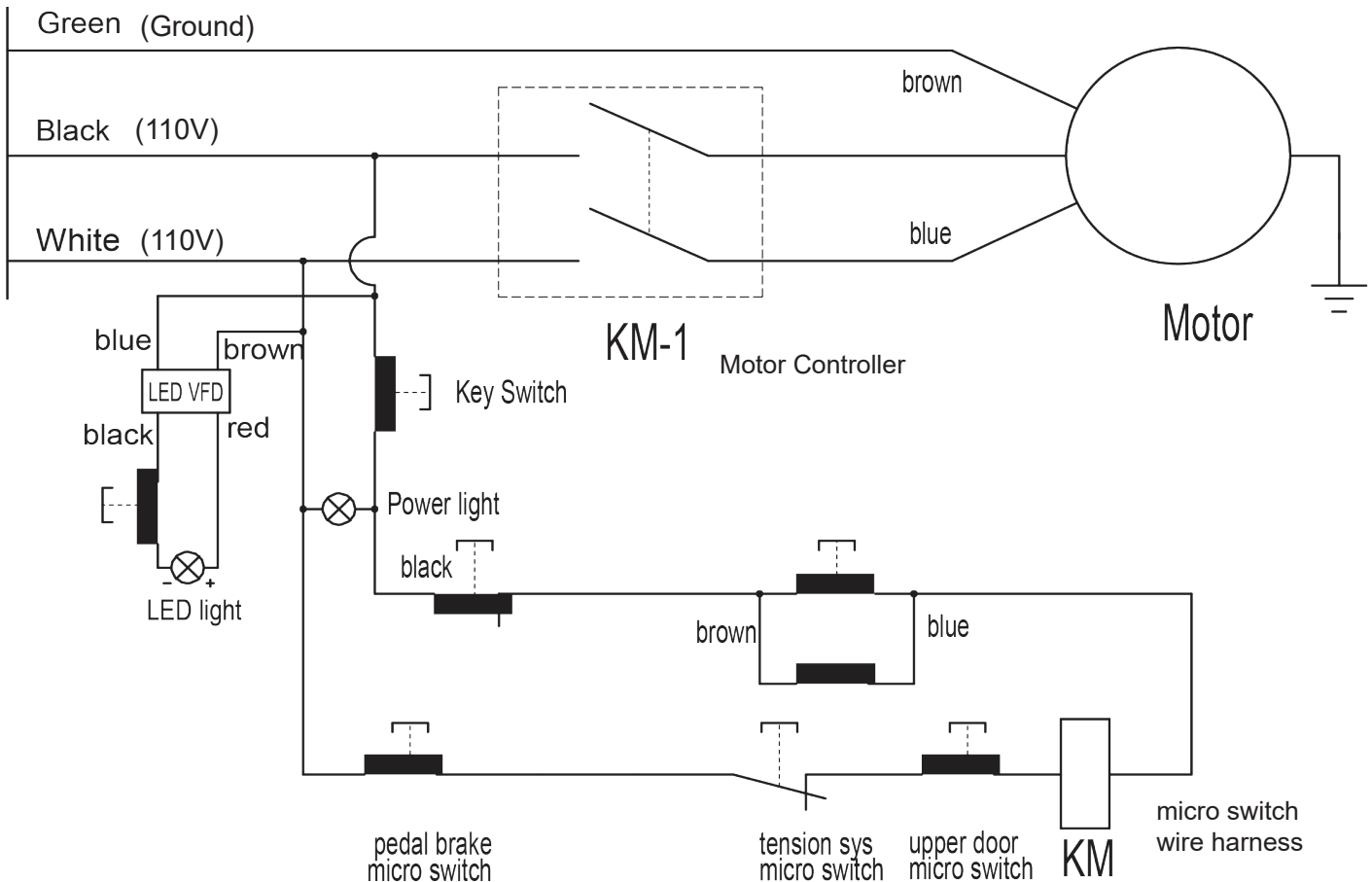

TROUBLESHOOTING

⚠ WARNING FOR YOUR OWN SAFETY, ALWAYS TURN OFF AND UNPLUG THE MACHINE BEFORE CARRYING OUT ANY TROUBLESHOOTING.

TROUBLE	PROBABLE CAUSE	REMEDY
The machine does not work when switched on.	<ol style="list-style-type: none"> 1. No power supply. 2. Defective switch. 	<p>Check the cable for breakage. Contact your local dealer for repair.</p>
The blade does not move with the motor running.	<ol style="list-style-type: none"> 1. The quick release lever or blade tension handwheel has not been tightened. 2. The blade has come off one of the wheels. 3. The saw blade has broken. 4. The drive belt has snapped. 	<p>Switch off the motor, tighten the quick release lever or blade tension handwheel. Open the hinged door and check. Replace the blade. Replace the belt.</p>
The blade does not cut in a straight line.	<ol style="list-style-type: none"> 1. Fence for cutting not used. 2. Too fast feed rate. 3. The blade teeth are dull or damaged. 4. Blade guides not suitably adjusted. 	<p>Use a fence. Put light pressure on the workpiece & make sure the blade does not bend. Use a new blade. Adjust the blade guides (see the section on page 15).</p>
The blade does not cut, or cuts very slowly.	<ol style="list-style-type: none"> 1. The teeth are dull, caused by cutting hard material or long use. 2. The blade was mounted in the wrong direction. 	<p>Replace the blade, use a 6 T.P.I. blade for wood and soft materials. Use a 14 T.P.I. blade for harder materials. A 14 T.P.I. blade always cuts slower due to the finer teeth and the slower cutting performance. Fit the blade correctly.</p>
Sawdust builds up inside the machine.	<ol style="list-style-type: none"> 1. This is normal 	<p>Clean the machine regularly. Open the hinged door and remove the sawdust with a vacuum cleaner.</p>
Sawdust inside the motor housing.	<ol style="list-style-type: none"> 1. Excessive dust build-up on the machine exterior components. 	<p>Clean the ventilating slots of the motor with a vacuum cleaner. From time to time remove the sawdust to prevent it from being sucked into the housing</p>
The machine does not cut at 45° or 90° angles.	<ol style="list-style-type: none"> 1. The table is not at right angles to the blade. 2. The blade is dull or too much pressure was put on the workpiece. 	<p>Adjust the table. Replace the blade or put less pressure on the workpiece.</p>
The blade cannot be properly positioned on the bandwheels.	<ol style="list-style-type: none"> 1. The blade tracking knob hasn't been properly adjusted. 2. Inferior blade. 3. The wheels are not in alignment. 	<p>Adjust the tracking knob (see page 12). Replace the blade. Adjust the lower wheel (see pages 22 & 23) Contact Technical Support @ 877-884-5167 or techsupport@rikontools.com.</p>

For parts or technical questions contact: techsupport@rikontools.com or 877-884-5167.

TROUBLESHOOTING

CHANGING THE MOTOR DRIVE BELT

(Refer to “Frame Assembly” parts diagram on page 26 and “Wheel Assembly” parts diagram on page 28)

Before changing the belt, make sure that the bandsaw is unplugged from the power source.

Release the saw blade tension from the drive belt by turning the quick release blade tension lever.

From the inside the machine, loosen the two Hex Bolts (Part #92A, Fig. 40, A) that secure the motor to the frame. Loosen the Hex Nut (Part #54A, Fig. 40, B) on the top of the Motor Adjusting Rod. The motor should now be loose enough to move downward for adjusting the belt.

Remove the lower wheel (Wheel Assembly, Part #9B) by removing the hex head bolt (Part #1B, Fig. 41, A) and washer in the middle of the wheel’s hub. Carefully slide the lower wheel off of the lower wheel shaft, and at the same time remove the saw blade from this wheel.

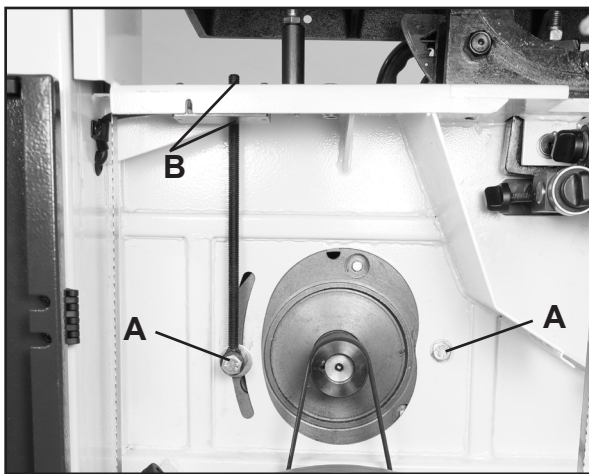

Figure 40



Figure 41

Remove the old drive belt from the wheel’s pulley, and install the new belt. Make sure that the ribs in the drive belt are seated correctly in the pulley before reassembling and tensioning the drive belt.

Reverse the procedure to re-assemble the saw parts. Tension the drive belt until there is 3/8” to 1/2” of deflection. For less tension on the drive belt, push the motor downward. For more tension on the drive belt, lift the motor upwards. See page 18: ADJUSTING THE DRIVE BELT TENSION.

NOTE: There is a second hex nut (Part #54A, Fig. 40, B) on the motor pulling rod that is located under the frame. This second hex nut must be loosened to allow the motor to be lifted upwards. When the belt tension is correct, tighten the motor mounting nuts that were loosened in the above steps.

CHANGING BANDSAW TIRES

Use a putty knife to get underneath the tire and pull it up and away from the wheel. Work the putty knife all the way around the wheel to loosen the tire. Then, use the putty knife as leverage to flip the tire over and off of the wheel. Clean the inside of the groove, removing any dirt, debris or cement with lacquer thinner.

Soak the replacement tire in warm water to make it more flexible. Dry the tire, and while it is still warm, lay it on top of the wheel. Start by setting the tire into the wheel groove at the top of the wheel. Using a putty knife, work the new tire around the wheel, making sure not to slice the tire. If rubber cement is to be used as a binder, make sure to distribute it evenly. Having high spots between the wheel and the tire will cause a vibration and effect blade tracking.

TROUBLESHOOTING

LOWER WHEEL ADJUSTMENTS

The following instructions will correct common blade issues related to the lower wheel's alignment in relation to the upper wheel. These adjustments will correct the blade position on the lower wheel and blade oscillation (wobble). These are critical adjustments which affect the performance and accuracy of the bandsaw.

CAUTION PLEASE READ AND UNDERSTAND THESE STEPS THOROUGHLY BEFORE MAKING ANY ADJUSTMENTS. FAILURE TO DO SO COULD DAMAGE THE MACHINE.

Please contact a tech support representative if you have questions before attempting these adjustments. RIKON Tech Support 877-884-5167 techsupport@rikontools.com

Release the blade tension completely before making any lower wheel adjustments. Pressure must be released on the lower wheel to allow proper adjustments and to avoid damaging the machine.

If the blade is not running true, or it is not running on center of the lower wheel but is correct on the upper wheel, then an adjustment to the wheel hub on the rear of the bandsaw is required.

The numbers shown on the rear hub photo represent the positions on a clock face.

NOTE: To help identify the extent of rotation on a bolt, mark a black dot on the edge of the bolt as a visual indicator.

If a blade is tracking forward on the lower wheel toward the door, follow these correction steps:

- 1.) De-tension the saw blade.
- 2.) Loosen 9 o'clock shaft bolt to take pressure off the shaft.
- 3.) Loosen 12 o'clock shaft bolt one half rotation.
- 4.) Tighten the 6 o'clock shaft bolt until the shaft touches the 12 o'clock adjusting bolt.
- 5.) Lock all three shaft bolts.
- 6.) Re-tension the saw blade and set the upper wheel to plumb by adjusting the tracking knob. Spin the upper wheel by hand and track the blade.
- 7.) Repeat if further adjustment is necessary.

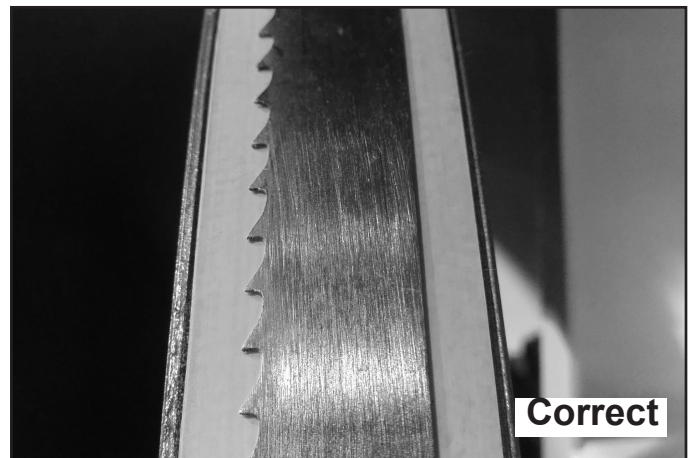
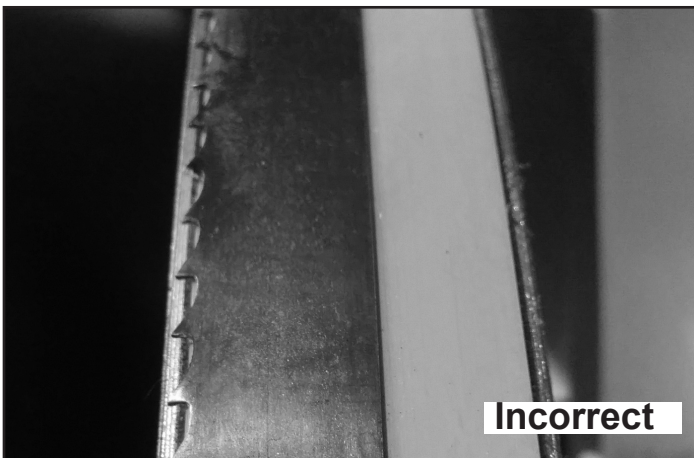
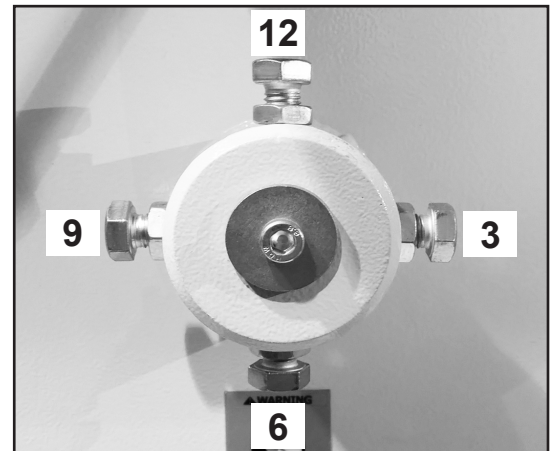

TROUBLESHOOTING

If a blade is tracking on the rear of the lower wheel, away from the door, follow these steps:

- 1.) De-tension the saw blade.
- 2.) Loosen 9 o'clock shaft bolt to take pressure off the shaft.
- 3.) Loosen 6 o'clock shaft bolt one half rotation.
- 4.) Tighten the 12 o'clock shaft bolt until the shaft touches the 6 o'clock adjusting bolt.
- 5.) Lock all three shaft bolts.
- 6.) Re-tension the saw blade and set the upper wheel to plumb by adjusting the tracking knob. Spin the upper wheel by hand and track the blade.
- 7.) Repeat if further adjustment is necessary.

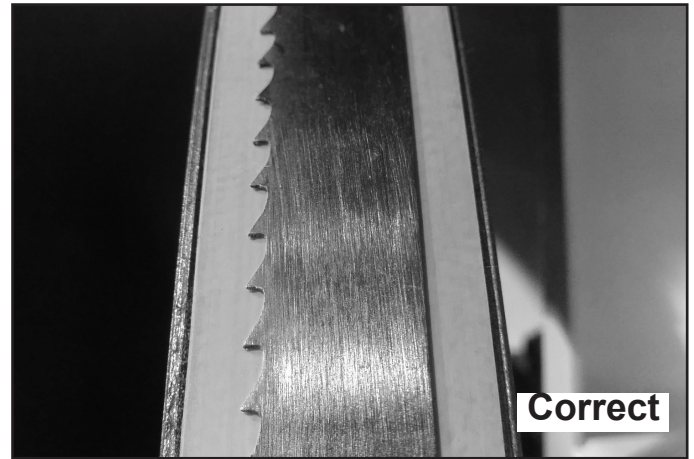
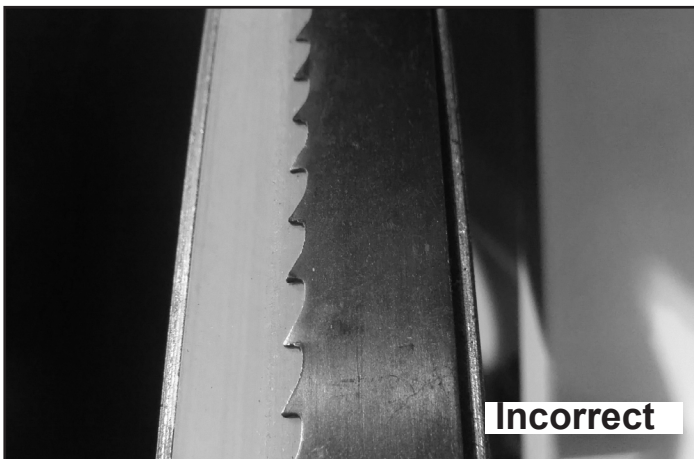

If a blade is moving back and forth (wobbling) follow these steps:

First, check the bandsaw blade to insure that it has been welded correctly, so that the blade's back is in proper alignment - flat (if it is laid down on a table surface).

If the blade is welded true, then adjustment to the wheel hub on the rear of the bandsaw is required.

- 1.) De-tension the saw blade.
- 2.) Loosen 6 o'clock shaft bolt to take pressure off of the shaft.
- 3.) Loosen 9 o'clock shaft bolt one half rotation.
- 4.) Tighten the 3 o'clock shaft bolt until the shaft touches the 9 o'clock adjusting bolt.
- 5.) Lock all three shaft bolts.
- 6.) Re-tension the saw blade and set the upper wheel to plumb by adjusting the tracking knob. Spin the upper wheel by hand and track the blade.
- 7.) Start the bandsaw and check blade movement.
- 8.) If movement has diminished then continue with the adjustment.
- 9.) If movement is worse, reverse the adjustments in steps 3 and 4.

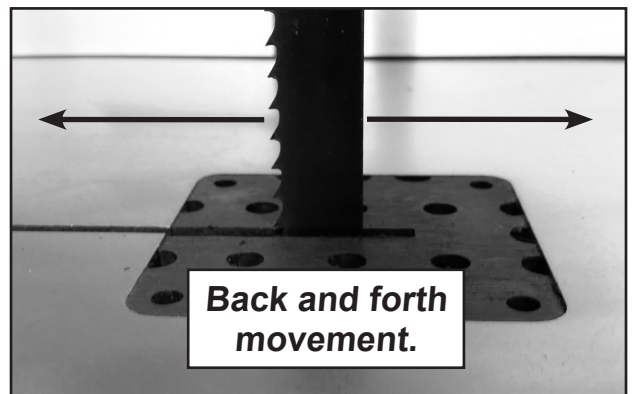

PARTS DIAGRAM

FRAME ASSEMBLY A

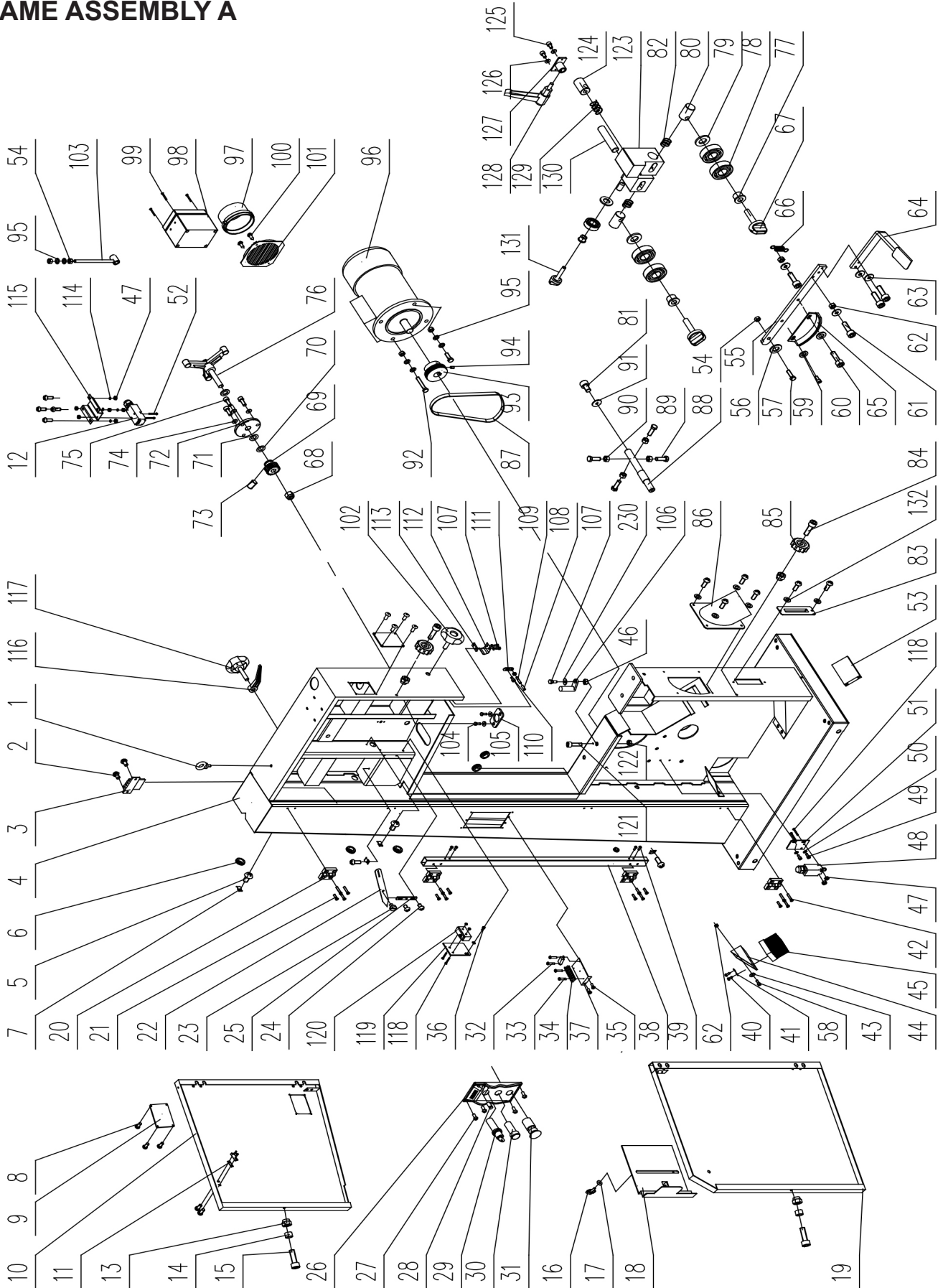

PARTS LIST

FRAME ASSEMBLY A

KEY NO.	DESCRIPTION	QTY	MFG. PART NO.	KEY NO.	DESCRIPTION	QTY	MFG. PART NO.
1A	Support Ring	1	P10-347-1A	67A	Clamp handle	2	P10-347-67A
2A	Cross recess pan hd screw M5X10	2	P10-347-2A	68A	Self-locking nut	1	P10-347-68A
3A	Tool holder	1	P10-347-3A	69A	Gear	1	P10-347-69A
4A	Frame	1	P10-347-4A	70A	Belleville spring	1	P10-347-70A
5A	Cross recess pan hd screw M4X10	13	P10-347-5A	71A	Flat washer	2	P10-347-71A
6A	Protecting bush	3	P10-347-6A	72A	Spacer bush	1	P10-347-72A
7A	Pressing plate	3	P10-347-7A	73A	Set screw M6X12	2	P10-347-73A
8A	Rivet	8	P10-347-8A	74A	Big washer	3	P10-347-74A
9A	Clear Window	2	P10-347-9A	75A	Hex socket cap screw M6X20	3	P10-347-75A
10A	Upper door	1	P10-347-10A	76A	Hand wheel	1	P10-347-76A
11A	Thread plate	1	P10-347-11A	77A	Bearing bush	3	P10-347-77A
12A	Microswitch	1	P10-347-12A	78A	Bearing	5	P10-347-78A
13A	Locknut	4	P10-347-13A	79A	Washer	3	P10-347-79A
14A	Bushing	2	P10-347-14A	80A	Guide shaft	2	P10-347-80A
15A	Hex socket cap screw M6X20	2	P10-347-15A	81A	Hex socket cap screw M8X12	1	P10-347-81A
16A	Wing nut	1	P10-347-16A	82A	Guide seat	1	P10-347-82A
17A	Big washer	1	P10-347-17A	83A	Side cover	1	P10-347-83A
18A	Protective cover	1	P10-347-18A	84A	Hex socket cap screw M6X25	2	P10-347-84A
19A	Lower door	1	P10-347-19A	85A	Handle	2	P10-347-85A
20A	Plastic hinge	4	P10-347-20A	86A	Suction inlet	1	P10-347-86A
21A	Hex socket countersunk hd M6X20	12	P10-347-21A	87A	Micro V-belt	1	P10-347-87A
22A	Indicator	1	P10-347-22A	88A	Lower guide wheel shaft	1	P10-347-88A
23A	Screw	1	P10-347-23A	89A	Hex bolt M12X40	4	P10-347-89A
24A	Cross recess pan head screw M5X10	2	P10-347-24A	90A	Hex nut	4	P10-347-90A
25A	Batter board	1	P10-347-25A	91A	Washer	1	P10-347-91A
26A	Switch box	1	P10-347-26A	92A	Hex bolt M10X60	1	P10-347-92A
27A	Cross recess pan head screw M4X12	4	P10-347-27A	93A	Motor pulley	1	P10-347-93A
28A	Power light	1	P10-347-28A	94A	Set screw M8X12	1	P10-347-94A
29A	Key switch	1	P10-347-29A	95A	Flat washer	4	P10-347-95A
30A	Start button	1	P10-347-30A	96A	Motor 4HP, 220V	1	P10-347-96A
31A	Stop button	1	P10-347-31A	97A	Suction port	1	P10-347-97A
32A	Cross recess pan head screw M3X12	2	P10-347-32A	98A	Relay	1	P10-347-98A
33A	Cross recess pan head screw M3X5	2	P10-347-33A	99A	Cross recess pan hd M4X16	4	P10-347-99A
34A	Wire holder	1	P10-347-34A	100A	Cross recessed pan hd tapping	2	P10-347-100A
35A	Screw M4X10	2	P10-347-35A	101A	Suction grille	1	P10-347-101A
36A	Hex socket cap screw M5X10	1	P10-347-36A	102A	Clamp handle	1	P10-347-102A
37A	Wiring board	1	P10-347-37A	103A	Pull rod	1	P10-347-103A
38A	Joint pin	1	P10-347-38A	104A	Hex bolt M6X16	2	P10-347-104A
39A	Screw M6X12	4	P10-347-39A	105A	Guide block	1	P10-347-105A
40A	Tapping screw	2	P10-347-40A	106A	Heel block	1	P10-347-106A
41A	Flat washer	6	P10-347-41A	107A	Stud shaft	1	P10-347-107A
42A	Hex socket countersunk hd M6X30	4	P10-347-42A	108A	Plastic pipe	1	P10-347-108A
43A	Big washer	3	P10-347-43A	109A	Set screw	1	P10-347-109A
44A	Sawdust brush holder	1	P10-347-44A	110A	Hex socket cap screw M6X10	1	P10-347-110A
45A	Brush	1	P10-347-45A	111A	Adjustment panel	1	P10-347-111A
46A	Hex nut M8	2	P10-347-46A	112A	Spring	1	P10-347-112A
47A	Hex nut M4	8	P10-347-47A	113A	Pressing plate	1	P10-347-113A
48A	Microswitch	1	P10-347-48A	114A	Flat washer	4	P10-347-114A
49A	Hex socket cap screw M6X12	2	P10-347-49A	115A	Switch base	1	P10-347-115A
50A	Flat washer	2	P10-347-50A	116A	Handle locking	1	P10-347-116A
51A	Switch plate	1	P10-347-51A	117A	Adjust lever	1	P10-347-117A
52A	Cross recess pan head screw M4X30	2	P10-347-52A	118A	Cross recessed countersunk M4X30	4	P10-347-118A
53A	Dust collection plate	1	P10-347-53A	119A	Switch plate	1	P10-347-119A
54A	Hex nut	3	P10-347-54A	120A	Microswitch	1	P10-347-120A
55A	Connecting rod	1	P10-347-55A	121A	Hex socket cap screw M5X10	1	P10-347-121A
56A	Flat washer	1	P10-347-56A	122A	Nut	1	P10-347-122A
57A	Hex bolt M10X35	1	P10-347-57A	123A	Lower guide	1	P10-347-123A
58A	Hex socket cap screw M6X12	1	P10-347-58A	124A	Rear guide shaft	1	P10-347-124A
59A	Flat washer	2	P10-347-59A	125A	Hex socket cap screw M6X12	2	P10-347-125A
60A	Hex socket cap screw M8X16	2	P10-347-60A	126A	Washer	2	P10-347-126A
61A	Hex socket cap screw M6X20	4	P10-347-61A	127A	Lower guide seat	1	P10-347-127A
62A	Hex nut	2	P10-347-62A	128A	Clamp handle	1	P10-347-128A
63A	Flat washer	4	P10-347-63A	129A	Spring	1	P10-347-129A
64A	Pedal	1	P10-347-64A	130A	Adjusting spindle	1	P10-347-130A
65A	Skate brake	1	P10-347-65A	131A	Clamp handle	1	P10-347-131A
66A	Tension spring	1	P10-347-66A				

PARTS DIAGRAM

WHEEL ASSEMBLY B

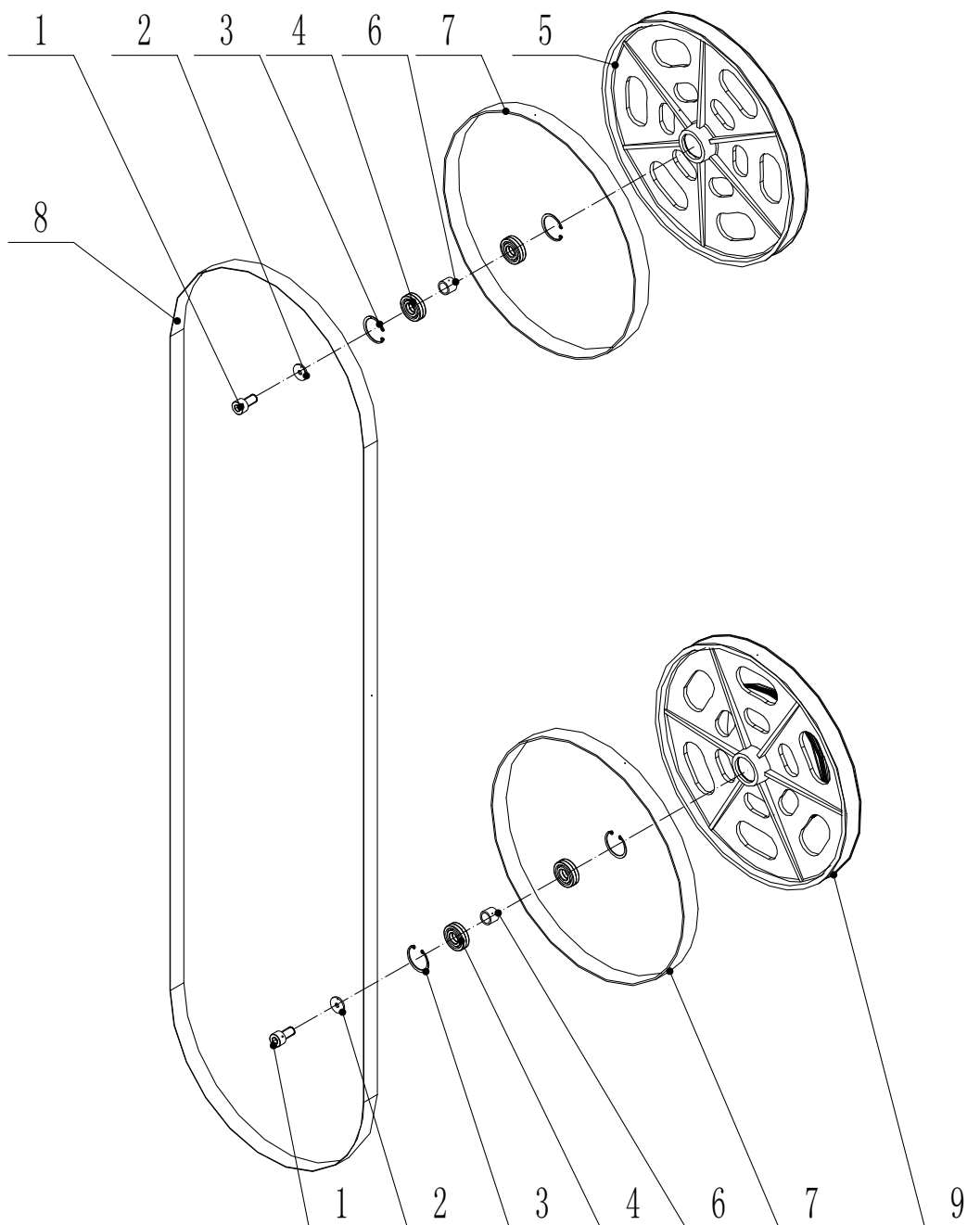

PARTS LIST

WHEEL ASSEMBLY B

KEY NO.	DESCRIPTION	QTY	MFG. PART NO.
1B	Hex socket cap screw M8X16	2	P10-347-1B
2B	Washer	2	P10-347-2B
3B	Circlip	4	P10-347-3B
4B	Bearing	4	P10-347-4B
5B	Upper wheel	1	P10-347-5B
6B	Spacer bushing	2	P10-347-6B
7B	Rubber tire	2	P10-347-7B
8B	Blade	1	P10-347-8B
9B	Lower wheel	1	P10-347-9B

NOTE: Please reference the Manufacturer's Part Number when calling for Replacement Parts.
For Parts under Warranty, the serial number of your machine is required.

PARTS DIAGRAM

TABLE ASSEMBLY C

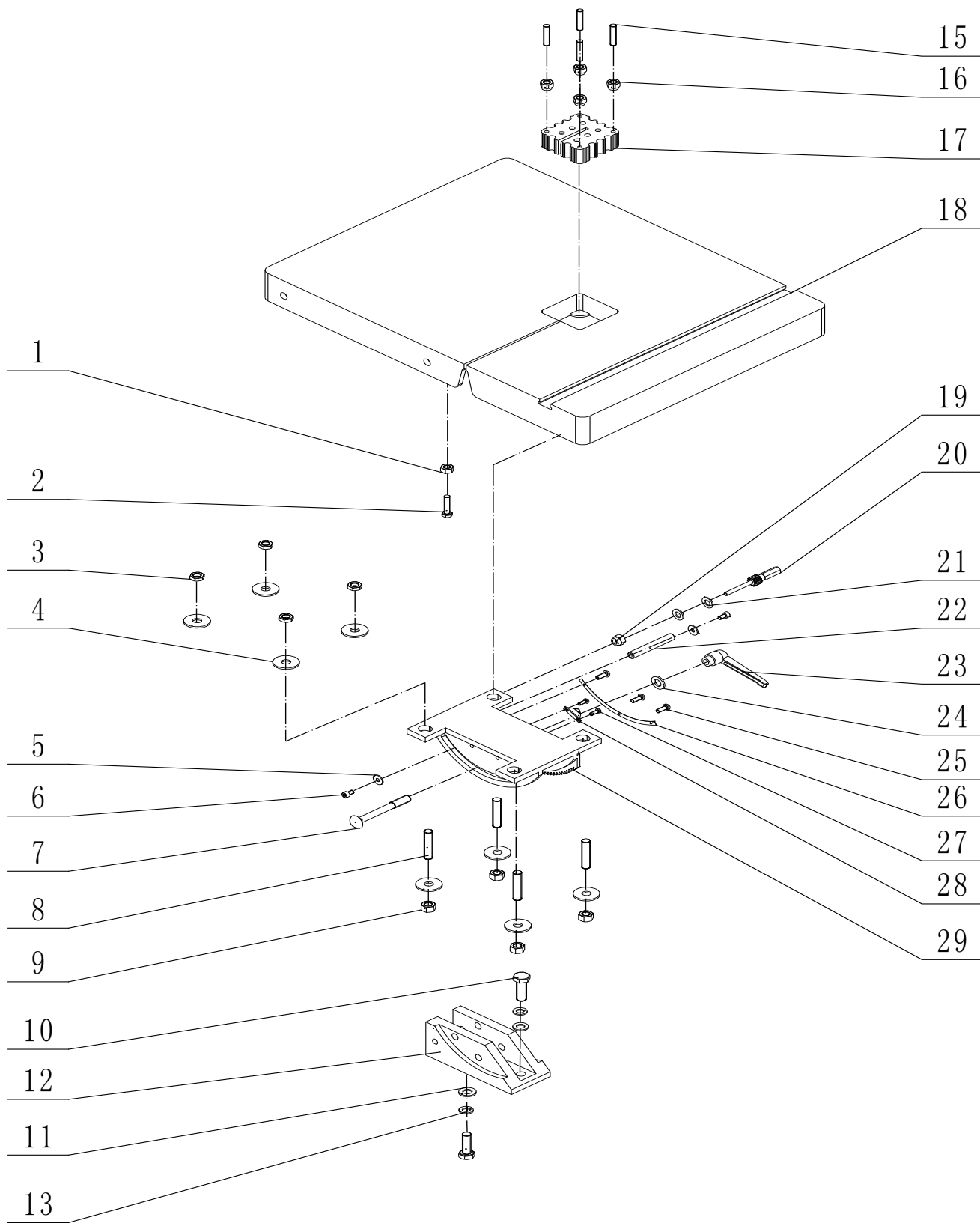

PARTS LIST

TABLE ASSEMBLY C

KEY NO.	DESCRIPTION	QTY	MFG. PART NO.
1C	Hex nut M8	1	P10-347-1C
2C	Hex bolt M8X30	1	P10-347-2C
3C	Nut	4	P10-347-3C
4C	Washer	8	P10-347-4C
5C	Big washer	2	P10-347-5C
6C	Hex socket cap screw M6X10	2	P10-347-6C
7C	Carriage bolt M12X100	1	P10-347-7C
8C	Set screw M12X60	4	P10-347-8C
9C	Hex nut M12	4	P10-347-9C
10C	Hex bolt M10X30	2	P10-347-10C
11C	Flat washer	4	P10-347-11C
12C	Table trunnion support	1	P10-347-12C
13C	Spring washer	2	P10-347-13C
14C	Hex nut M10	2	P10-347-14C
15C	Set screw M5X30	4	P10-347-15C
16C	Locking nut	4	P10-347-16C
17C	Table insert	1	P10-347-17C
18C	Table	1	P10-347-18C
19C	Self-locking nut	1	P10-347-19C
20C	Gear shaft	1	P10-347-20C
21C	Flat washer	2	P10-347-21C
22C	Guide shaft	1	P10-347-22C
23C	Clamp handle	1	P10-347-23C
24C	Flat washer	1	P10-347-24C
25C	Rivet	3	P10-347-25C
26C	Angle label	1	P10-347-26C
27C	Cross recess pan head screw M3X5	2	P10-347-27C
28C	Indicator	1	P10-347-28C
29C	Table trunnion assembly	1	P10-347-29C

NOTE: Please reference the Manufacturer's Part Number when calling for Replacement Parts.
For Parts under Warranty, the serial number of your machine is required.

PARTS DIAGRAM

BLADE TENSION & TRACKING D

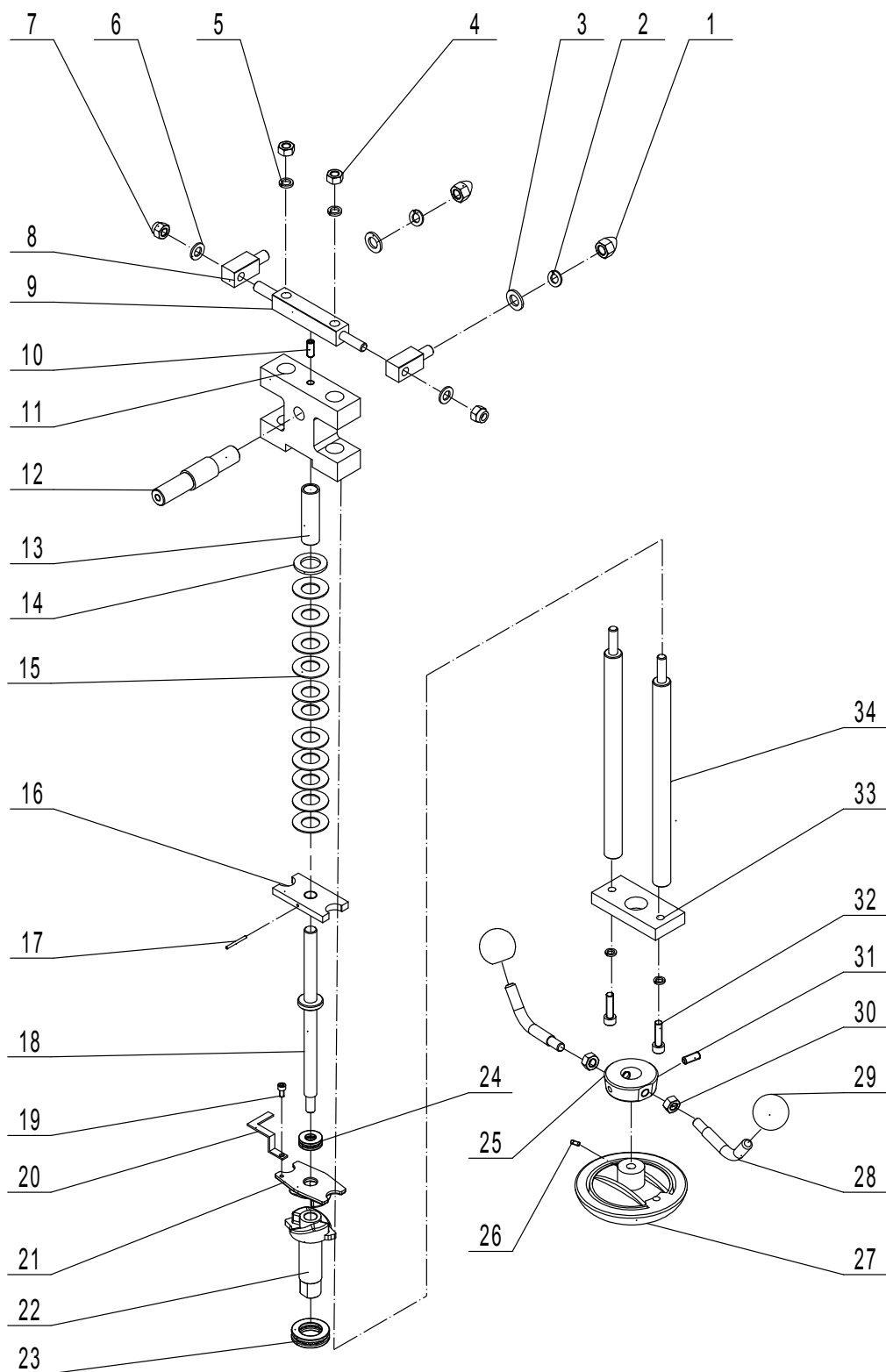

PARTS LIST

BLADE TENSIONING & TRACKING D

KEY NO.	DESCRIPTION	QTY	MFG. PART NO.
1D	Cap nut	2	P10-347-1D
2D	Spring washer	2	P10-347-2D
3D	Big washer	2	P10-347-3D
4D	Hex nut M10	2	P10-347-4D
5D	Spring washer	4	P10-347-5D
6D	Flat washer	2	P10-347-6D
7D	Locking nut	2	P10-347-7D
8D	Bolt	2	P10-347-8D
9D	Double-thread screw	1	P10-347-9D
10D	Set screw M8X25	1	P10-347-10D
11D	Sliding piece	1	P10-347-11D
12D	Upper wheel shaft	1	P10-347-12D
13D	Tube	1	P10-347-13D
14D	Flat washer	2	P10-347-14D
15D	Belleville spring	12	P10-347-15D
16D	Thread plate	1	P10-347-16D
17D	Roll pin	1	P10-347-17D
18D	Threaded rod	1	P10-347-18D
19D	Hex socket cap screw M5X10	1	P10-347-19D
20D	Pressing plate	1	P10-347-20D
21D	Upper piece	1	P10-347-21D
22D	Lower piece	1	P10-347-22D
23D	Bearing	1	P10-347-23D
24D	Bearing	1	P10-347-24D
25D	Handle cover	1	P10-347-25D
26D	Hex socket cap screw M6X12	1	P10-347-26D
27D	Handle	1	P10-347-27D
28D	Handle lever	2	P10-347-28D
29D	Knob	2	P10-347-29D
30D	Nut	2	P10-347-30D
31D	Screw M8X20	1	P10-347-31D
32D	Hex socket cap screw M10X30	2	P10-347-32D
33D	Support plate	1	P10-347-33D
34D	Slide bar	2	P10-347-34D

NOTE: Please reference the Manufacturer's Part Number when calling for Replacement Parts.
For Parts under Warranty, the serial number of your machine is required.

PARTS DIAGRAM

GUIDE POST ASSEMBLY E

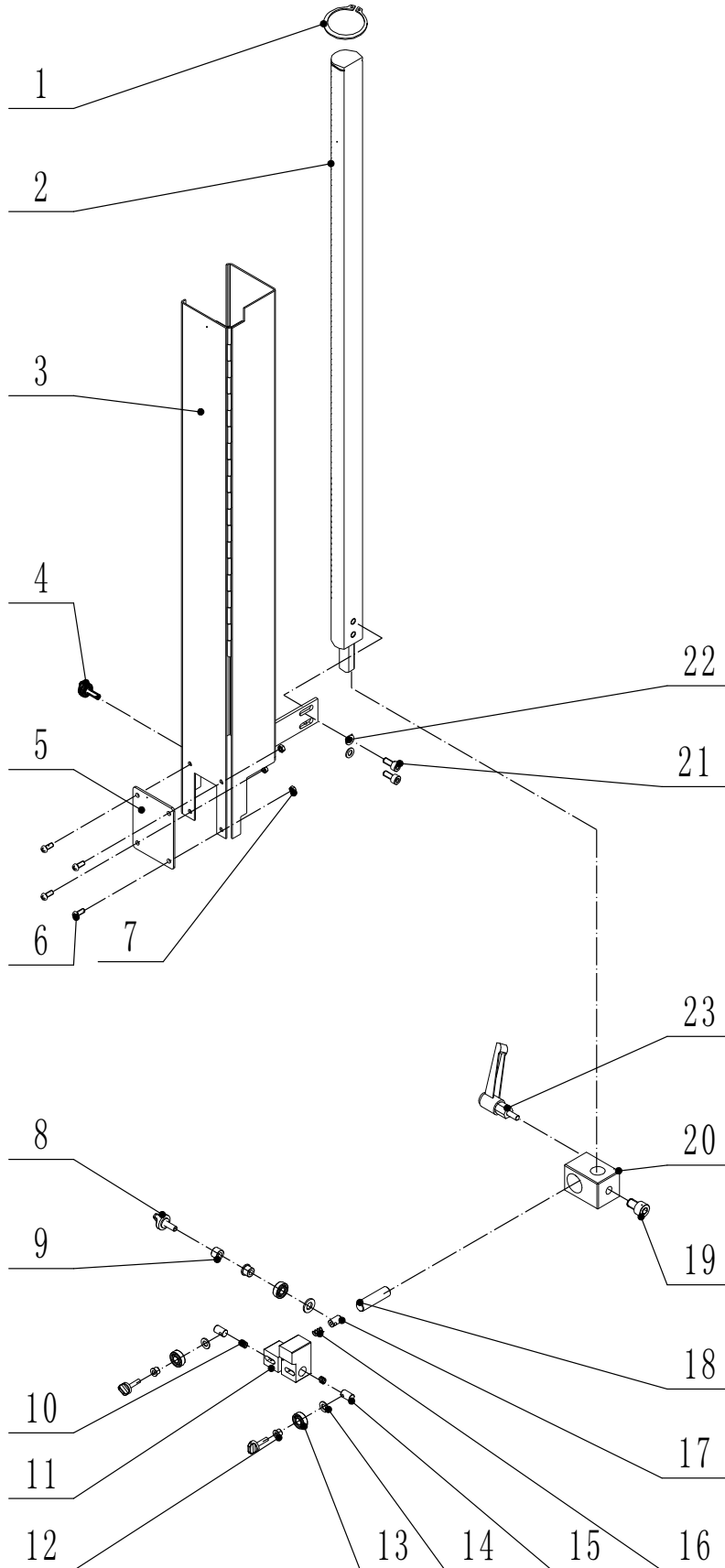

PARTS LIST

GUIDE POST ASSEMBLY E

KEY NO.	DESCRIPTION	QTY	MFG. PART NO.
1E	Circlip ring	1	P10-347-1E
2E	Rack	1	P10-347-2E
3E	Blade guard assembly	1	P10-347-3E
4E	Clamp handle	2	P10-347-4E
5E	Window	1	P10-347-5E
6E	Cross recess pan hd screw M4X8	4	P10-347-6E
7E	Nut	4	P10-347-7E
8E	Clamp handle	3	P10-347-8E
9E	Heel block	1	P10-347-9E
10E	Spring	2	P10-347-10E
11E	Upper guide	1	P10-347-11E
12E	Bearing bushing	3	P10-347-12E
13E	Bearing	5	P10-347-13E
14E	Flat washer	3	P10-347-14E
15E	Guide shaft	2	P10-347-15E
16E	Spring	1	P10-347-16E
17E	Rear guide shaft	1	P10-347-17E
18E	Support bar	1	P10-347-18E
19E	Set screw M6X12	1	P10-347-19E
20E	Link block	1	P10-347-20E
21E	Bolt M5X12	2	P10-347-21E
22E	Flat washer	2	P10-347-22E
23E	Clamp Handle	1	P10-347-23E

NOTE: Please reference the Manufacturer's Part Number when calling for Replacement Parts.
For Parts under Warranty, the serial number of your machine is required.

PARTS DIAGRAM & PARTS LIST

FENCE ASSEMBLY F

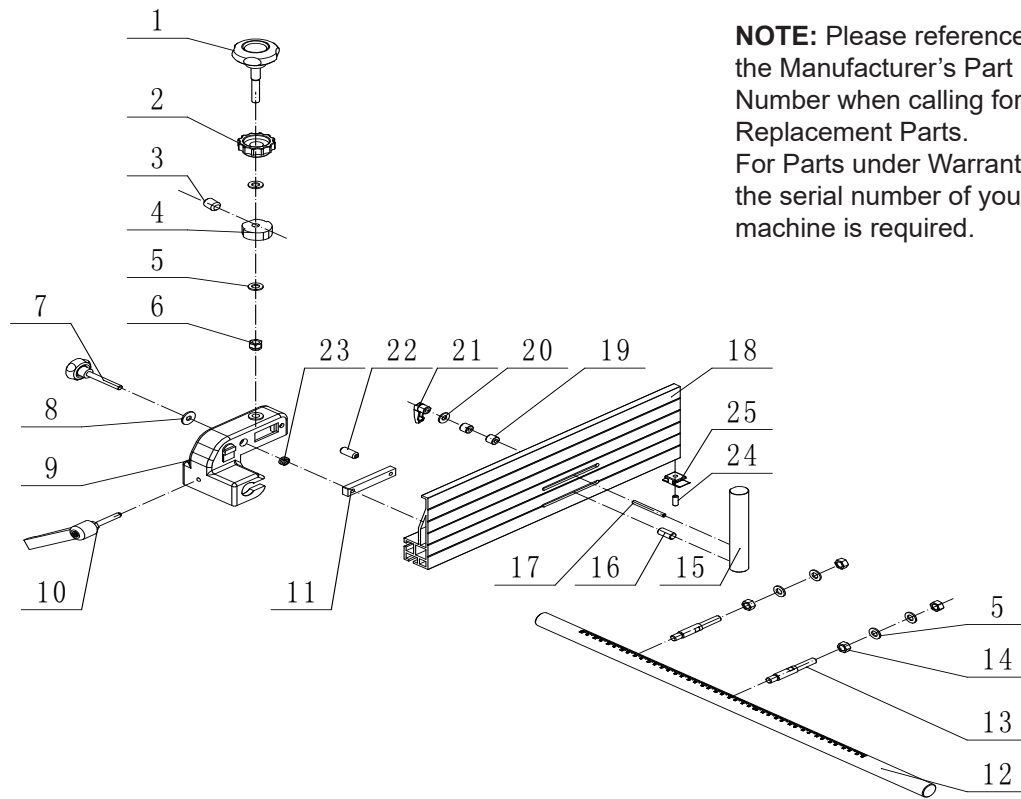

NOTE: Please reference the Manufacturer's Part Number when calling for Replacement Parts. For Parts under Warranty, the serial number of your machine is required.

KEY NO.	DESCRIPTION	QTY	MFG. PART NO.
1F	Adjust Handle	1	P10-347-1F
2F	Locking Knob	1	P10-347-2F
3F	Socket head cap screw M8X10	1	P10-347-3F
4F	Cam	1	P10-347-4F
5F	Flat washer	6	P10-347-5F
6F	Nut M10	1	P10-347-6F
7F	Round handle	1	P10-347-7F
8F	Big washer	1	P10-347-8F
9F	Rip fence carrier	1	P10-347-9F
10F	Lock handle	1	P10-347-10F
11F	Sliding block	1	P10-347-11F
12F	Front guide rail	1	P10-347-12F
13F	Connecting rod	2	P10-347-13F
14F	Hex nut M10	4	P10-347-14F
15F	Re-saw bar	1	P10-347-15F
16F	Screw	1	P10-347-16F
17F	Bolt	1	P10-347-17F
18F	Rip fence	1	P10-347-18F
19F	Tube	1	P10-347-19F
20F	Flat washer	1	P10-347-20F
21F	Lock handle	2	P10-347-21F
22F	Roll pin	1	P10-347-22F
23F	Spring	1	P10-347-23F
24F	Set screw	1	P10-347-24F
25F	Nylon plate	1	P10-347-25F

ACCESSORIES

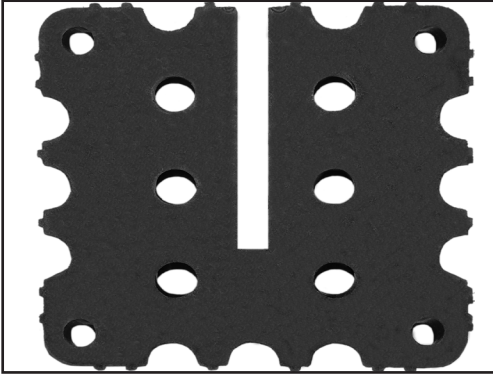

C10-396 TABLE INSERT

Replacement plastic insert with four-threaded holes for hex screw levelers.

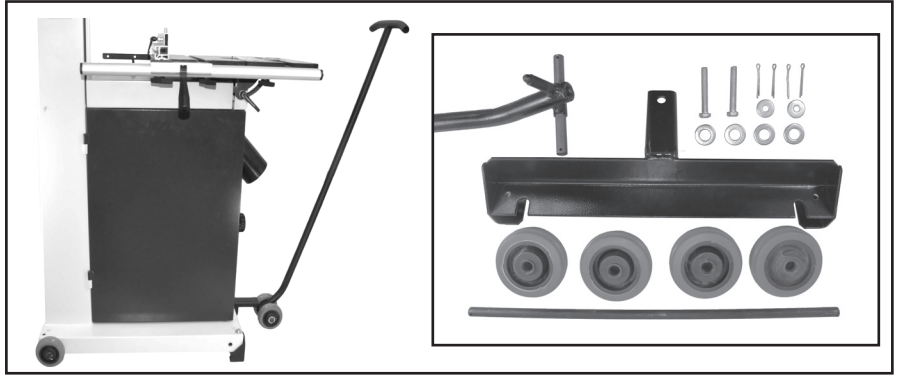

13-345 MOBILITY KIT Conversion Kit installs onto the bandsaw base to make it easy to move around the shop. Includes rear wheel assembly, front support, tow bar, hardware and instructions.

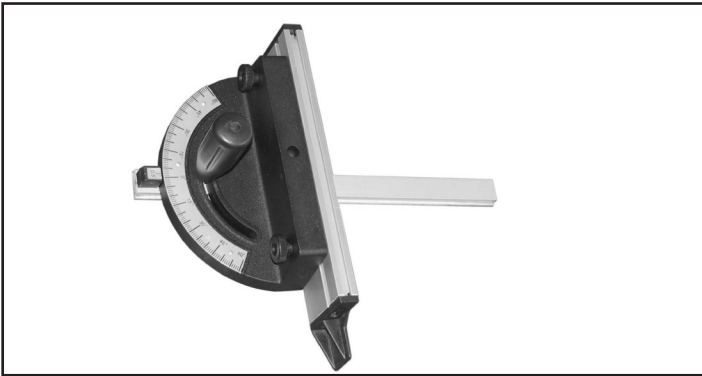

13-912 'T' SLOT MITER GAUGE

Fits 3/4" x 3/8" miter slots. Handy scale for up to 60° left and right angle settings, includes adjustable 9" aluminum fence extension and push handle.



BAND SAW BLADES

For a complete line of 162" band saw blades, contact your local RIKON Distributor, or visit the RIKON website at www.rikontools.com.

WARRANTY

RIKON

POWER TOOLS

5-Year Limited Warranty

RIKON Power Tools Inc. ("Seller") warrants to only the original retail consumer/purchaser of our products that each product be free from defects in materials and workmanship for a period of five (5) years from the date the product was purchased at retail. This warranty may not be transferred.

This warranty does not apply to defects due directly or indirectly to misuse, abuse, negligence, accidents, repairs, alterations, lack of maintenance or normal wear and tear. Under no circumstances will Seller be liable for incidental or consequential damages resulting from defective products. All other warranties, expressed or implied, whether of merchantability, fitness for purpose, or otherwise are expressly disclaimed by Seller. This five-year warranty does not cover products used for commercial, industrial or educational purposes. The warranty term for these claims will be limited to a two-year period.

This limited warranty does not apply to accessory items such as blades, drill bits, sanding discs, grinding wheels, belts, guide bearings and other related items.

Seller shall in no event be liable for death, injuries to persons or property, or for incidental, contingent, special, or consequential damages arising from the use of our products.

To take advantage of this warranty, proof of purchase documentation must be provided which has the date of purchase and an explanation of the complaint.

The Seller reserves the right to effect at any time, without prior notice, those alterations to parts, fittings, and accessory equipment which they may deem necessary for any reason whatsoever.

To take advantage of this warranty, please fill out the enclosed warranty card and send it to:

RIKON Warranty
16 Progress Rd.
Billerica, MA 01821

The card must be entirely completed in order for it to be valid. If you have any questions please contact us at 877-884-5167 or warranty@rikontools.com.



For more information:
16 Progress Rd
Billerica, MA 01821

877-884-5167 / 978-528-5380
techsupport@rikontools.com

