

# Assembly & Installation Guide

Model: DT20L Series

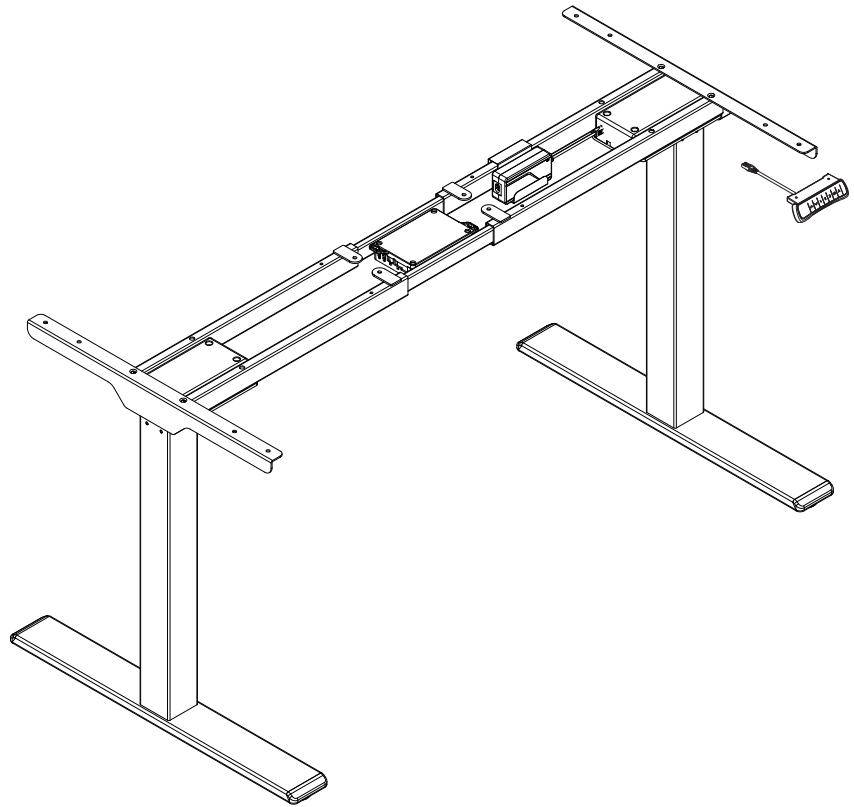

# ELECTRIC HEIGHT-ADJUSTABLE DESK



# Preface



This electric height-adjustable standing desk consists of a heavy-duty steel desk frame and a motorized height adjustment system. Please read and completely understand this manual before assembly and use.

## Instruction safety and warnings:

FAILURE TO COMPLY WITH OR OBSERVE ALL INSTRUCTIONS AND WARNINGS REGARDING THE USE OF THIS PRODUCT MAY RESULT IN SERIOUS PROPERTY DAMAGE OR PHYSICAL INJURY.



**DANGER** - To avoid the risk of electric shock, always unplug this furnishing before cleaning, putting on or taking off parts.

WARNING - To avoid the risk of burns, fire, electric shock, or physical injury:

- Keep children away from electric height-adjustable desks, control units, and keypads. There is a risk of injury and electric shock.
- Close supervision is necessary when this furnishing is used by, or near children, invalids, or the disabled.
- Use this furnishing only for its intended use as described in these instructions.
- Use attachments recommended by the manufacturer only.
- Make sure the power socket/outlet is close to the furnishing in use and easily accessible.
- Never operate on this furnishing when the cord or plug is damaged, it is not working properly, or it has been dropped into water.
- Keep the cords away from heated surfaces.
- Do not open any of the following components: legs, control box, or keypad. There is a danger of getting electric shock.

- Do not insert anything into any seam or opening.
- Keep all electrical components dry.
- Do not operate this furnishing in an environment where aerosol (spray) products are being used or oxygen is being administered.
- Do not use outdoors. Inappropriate use of this product may cause property damage or physical injury.
- Check surroundings on all sides before use. Body parts and property can be crushed if trapped in immobile obstacles and the desk's range of motion.
- Ensure the length of power cords are accounted for when operating the desk.
- Monitors, computers, speakers, anything with a cord that is not long enough for the desk's range of motion could be pulled down or have its wires broken. Items pulled off the desk may cause other items to fall.
- Pinch Point: Keep hands and fingers clear.
- Please provide this manual to users, installers, or support personnel operating the product.



MAKE SURE NO OBSTACLES ARE IN THE DESK'S PATH AND ALL CORDS ARE OF APPROPRIATE LENGTH FOR DESK TRAVEL. FAILURE TO COMPLY WITH OR OBSERVE ALL ASSEMBLY, SAFETY, AND OPERATION INSTRUCTIONS AND WARNINGS REGARDING THE USE OF THIS PRODUCT MAY RESULT IN SERIOUS PROPERTY DAMAGE OR PHYSICAL INJURY.

## Use and Liability:

This height-adjustable desk has two electric motors and is designed for use in dry work areas only. The desk height is adjustable so that it can be positioned at the most ergonomically suitable height. These desks are designed only for the purposes included in this manual. They should not be used in environments with high humidity or dampness. Any other use is at user's risk. Do not move around, crawl, or lie under the desk frame. Do not sit or stand on the desk frame. Children should never use the desk unless they are supervised by adults.

Liability: For damages caused from improper use or handling of the desk other than those described in this manual, there is no warranty.

# Preparation

## Tools Required



Bubble Level



Allen Wrench



Drill



Screwdriver

# Checklist

## Accessory List

Attention:

The drawings below are for guidance only and they may differ slightly from the product and fittings received.  
Please contact our customer service department if you have any questions.

**A**

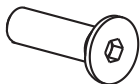

**M6\*4**

**B**

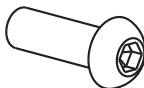

**M6\*8**

**C**

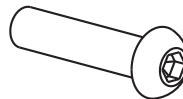

**M6\*8**

**D**



**St4.2\*6**

**E**



**Cable tie\*6**

**F**



**St4.2\*16**

**G**



**Allen key \*1**



# Checklist

## Part List

①

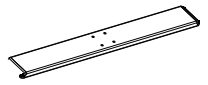

Feet\*2

②

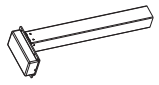

Lifting Column\*2

③

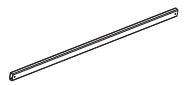

Connection Rod\*2

④

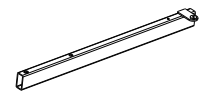

Left Supporting Beam\*2

⑤

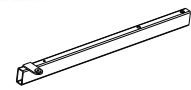

Right Supporting Beam\*2

⑥

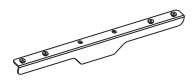

Side Bracket\*2

⑦



Adapter Arm\*1

⑧



Adapter\*1

⑨



Control Box\*1

⑩

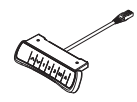

Handset (Option)\*1

⑪



Adapter Cabel\*1

⑫



Power Plug\*1

# Installation instruction

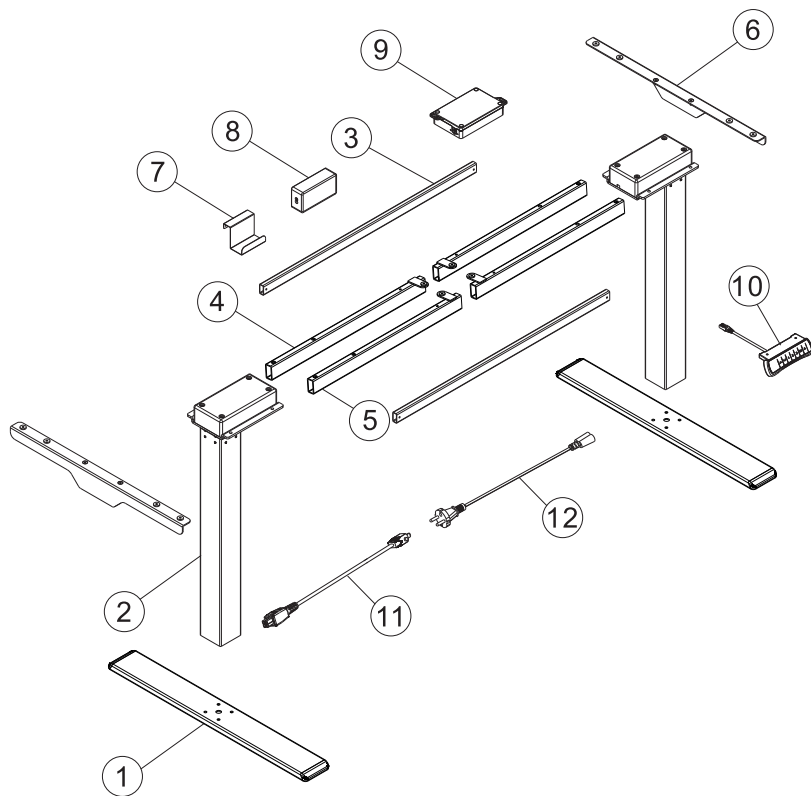

# Assembly



## Step 1: Install the supporting beam and the side bracket

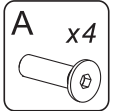

 If the connecting rod cannot be inserted into the supporting beam, please loosen the screws on the beam.

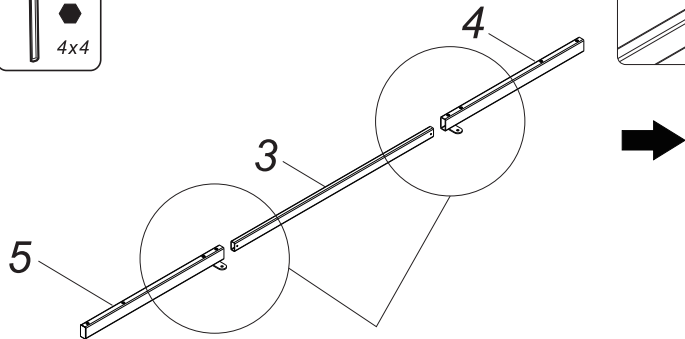
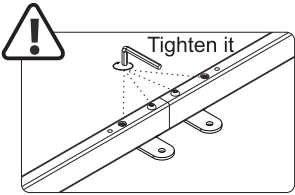

Connect the Connection rod (3) with the left supporting beam (4) and the right supporting beam (5), and tighten them with the allen key (G).

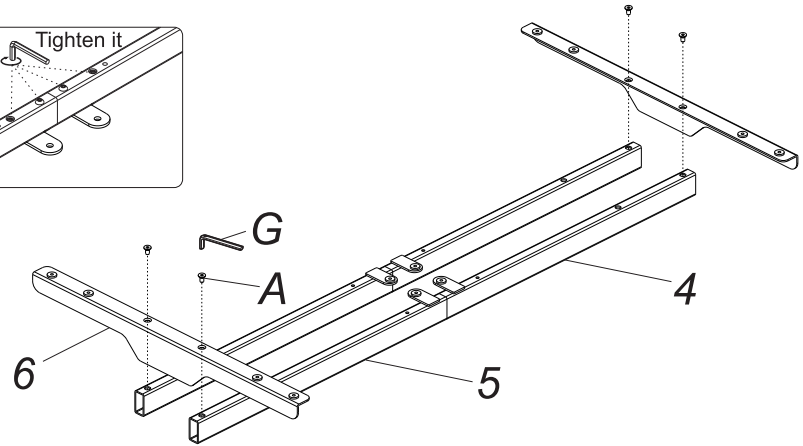

Using screws (A) to connect the side bracket (6) with the left supporting beam (4) and the right supporting beam (5), and tighten them with the allen key (G).

# Assembly



## Step 2: Install the lifting column

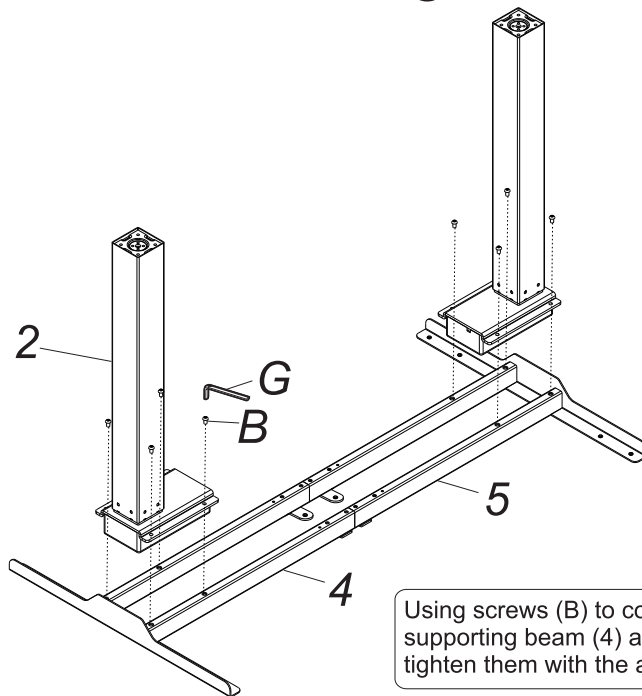
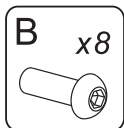

Using screws (B) to connect the lifting column (2) with the left supporting beam (4) and the right supporting beam (5), and tighten them with the allen key (G).

# Assembly



## Step 3: Install the feet

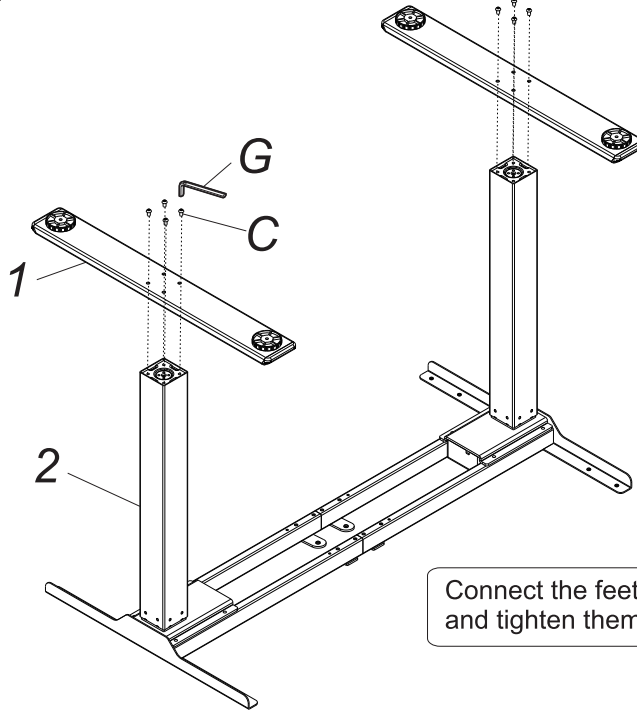
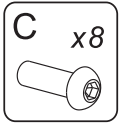

Connect the feet(1) and the lifting column (2) with screws (C), and tighten them with the allen key (G).

# Assembly



## Step 4: Install the adapter arm

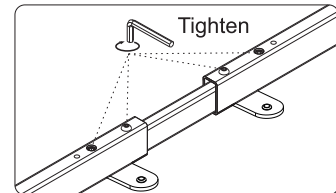
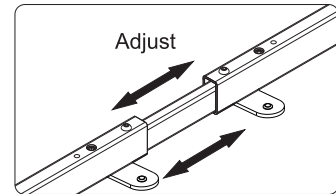
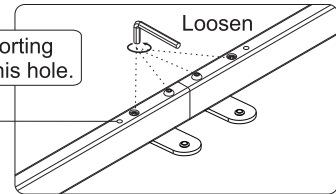
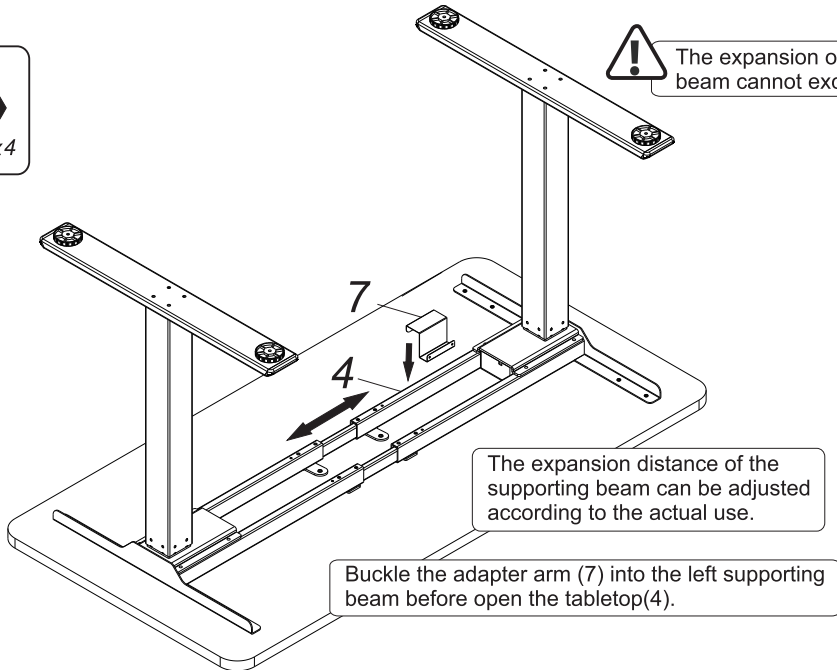

# Assembly



## Step 5: Install the tabletop, handset and adapter

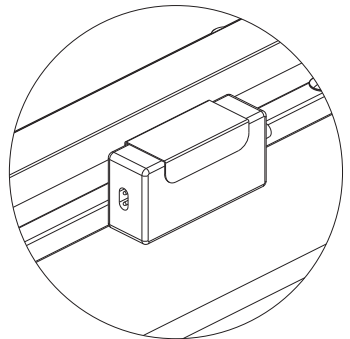
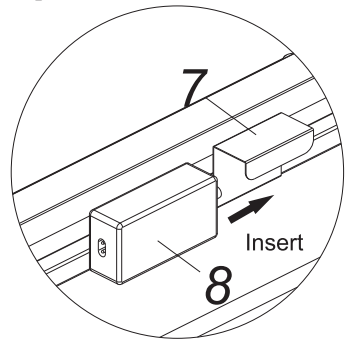
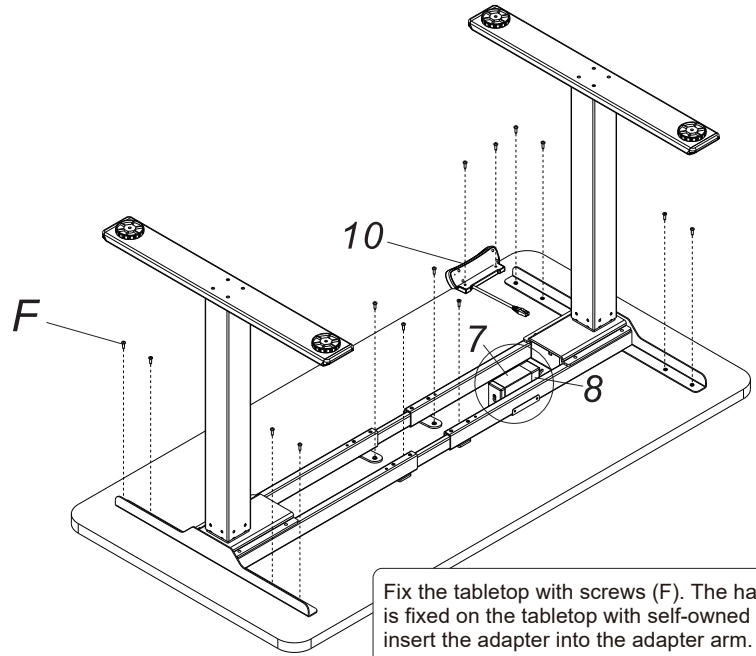
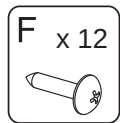

Fix the tabletop with screws (F). The handset (10) is fixed on the tabletop with self-owned screw and insert the adapter into the adapter arm.

# Assembly



## Step 6: Install the control box

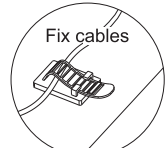
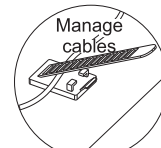
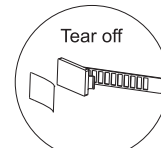
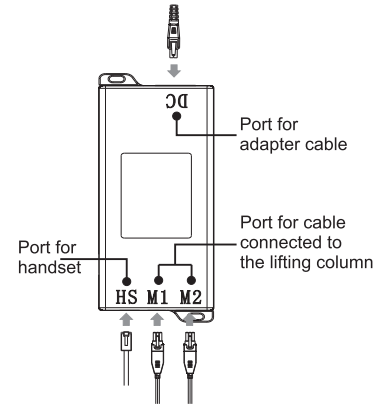
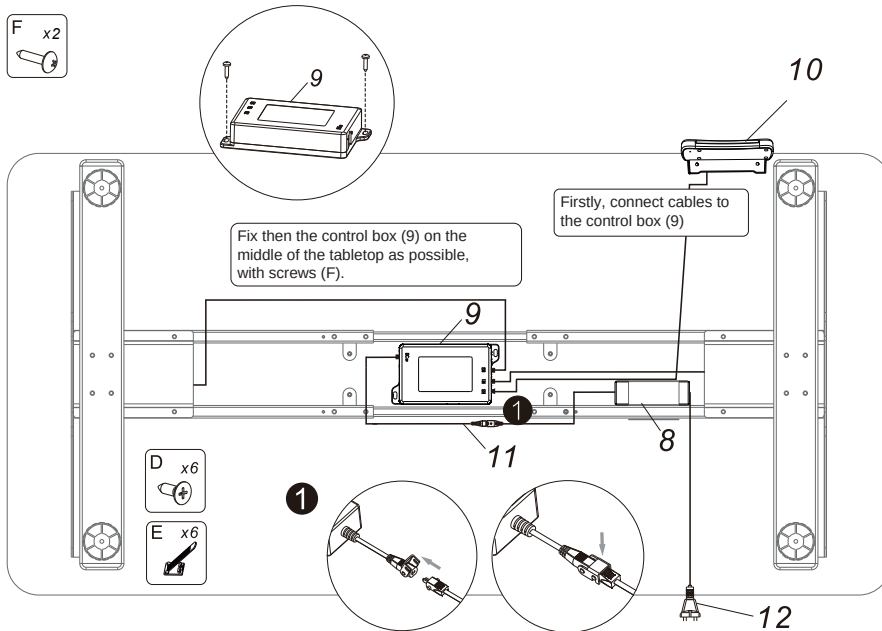

Fix the cables to the tabletop with cable management (E), and then use screw (D) to fix the cable management (E) to keep the desk cables organized.



# Technical Data

Column Stage	2
Max. Weight Capacity	100kg
Height Range	710-1200mm (without tabletop)
Width Range	1100-1700mm

# Common fault treatment



The following tips will help you detect and eliminate the common fault and error. If the fault you met is not listed below, please contact with your supplier. Only the manufacturer and professionals are capable for investigating and correcting those fault and error.

Fault phenomenon	Method
No response while long pressing down arrow after connected with a power supply	1. Check if all the cables be connected well 2. Contact your supplier or dealer
No response while pressing up arrow/down arrow after connected with a power supply	1. Check if all the cables be connected well 2. Contact your supplier or dealer
Rising in a low speed	1. Check if overloaded, max loading: 100kg 2. Contact your supplier or dealer
The motor not move as instructed	Contact your supplier or dealer
Go down but not go up	1. Reposition 2. Contact your supplier or dealer
Downward sliding	1. Check if overloaded, max loading: 100kg 2. Contact your supplier or dealer
Frequently Reposition	1. Check if overloaded, max loading: 100kg 2. Contact your supplier or dealer
Overwork (Duty cycle: Max 2min on/ 18min OFF)	1. Restart after suspend for 18mins while connecting with power 2. Contact your supplier or dealer
Not enough up&down height	1. Press "M" and "3" together for 3 seconds or more, after hearing continuous beeping for twice, it will restore factory settings 2. Contact your supplier or dealer



## Attention

- Power supply: AC100V-240V, 50/60 Hz.
- Service Environment: 0-40 °C.
- Unplug the power plug before cleaning, wipe the dust on surface with slight wet dishcloth when cleaning, be careful not to let the drops into the internal parts, not loose the connector.
- The electric box contains electronic components, metals, plastics, wires etc., so dispose of it in accordance with each country's environmental legislation, not the general household waste.
- Check carefully to ensure correct and complete assembly before using.
- Be familiar with all functions and program settings of the product before first use.
- Children are forbidden to play on the product because of unforeseen action when playing, so any dangerous consequences caused by this improper action will not be on manufacturers.
- Slight noise caused by the V-ribbed belt or brake system due to structure will not have any effect on the use of the equipment.
- Corrosive or abrasive materials are forbidden to clean the equipment. Must ensure that the cleaner used will not pollute the environment.



## Attention

- This appliance can be used by children aged from 8 years and above and persons with reduced physical, sensory or mental capabilities or lack of experience and knowledge if they have been given supervision or instruction concerning use of the appliance in a safe way and understand the hazards involved. Children shall not play with the appliance.
- Cleaning and user maintenance shall not be made by children without supervision.
- If the supply cord is damaged, it must be replaced by the manufacturer, its service agent or a similarly qualified person in order to avoid a hazard.
- Please make sure there is no hazard sources in your operating environment, e.g., do not litter the tools around. Always be careful to treat the packaging materials in order to avoid any possible danger, e.g. plastic bag may lead to choking hazard to children.
- Keep the original package of the equipment if necessary in case of the future use in transportation.

**Waste disposal**

This marking indicates that this product should not be disposed with other household wastes. To prevent possible harm to the environment or human health from uncontrolled waste disposal, recycle it responsibly to promote the sustainable reuse of material resources. To return your used device, please use the return and collection systems or contact the retailer where the product was purchased. They can take this product for environmental safe recycling.

**Importer:**  
**Ergofino GmbH**  
In Laisen 31, 72766, Reutlingen  
[www.ergofino.de](http://www.ergofino.de)