

Metric

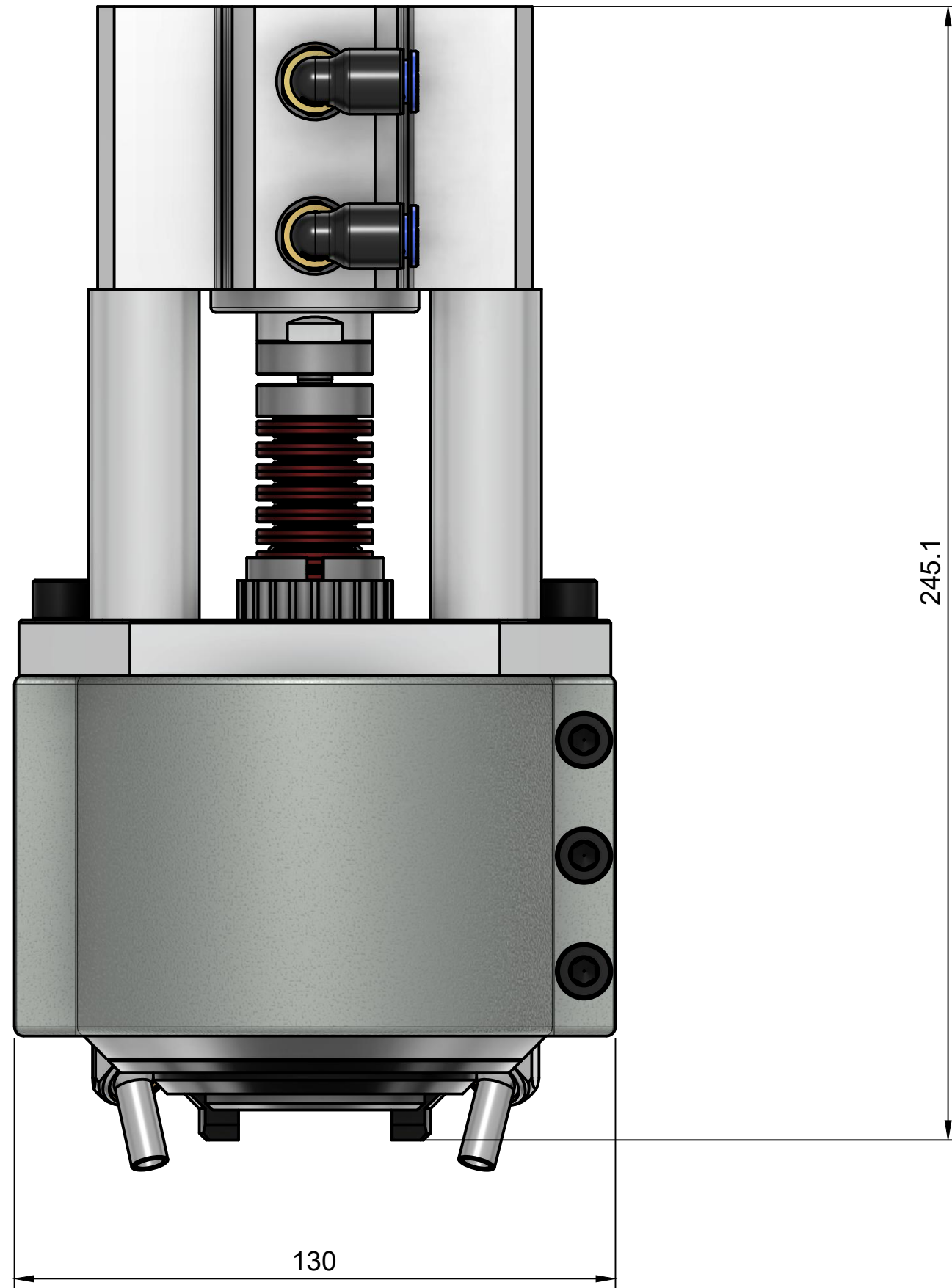

Imperial

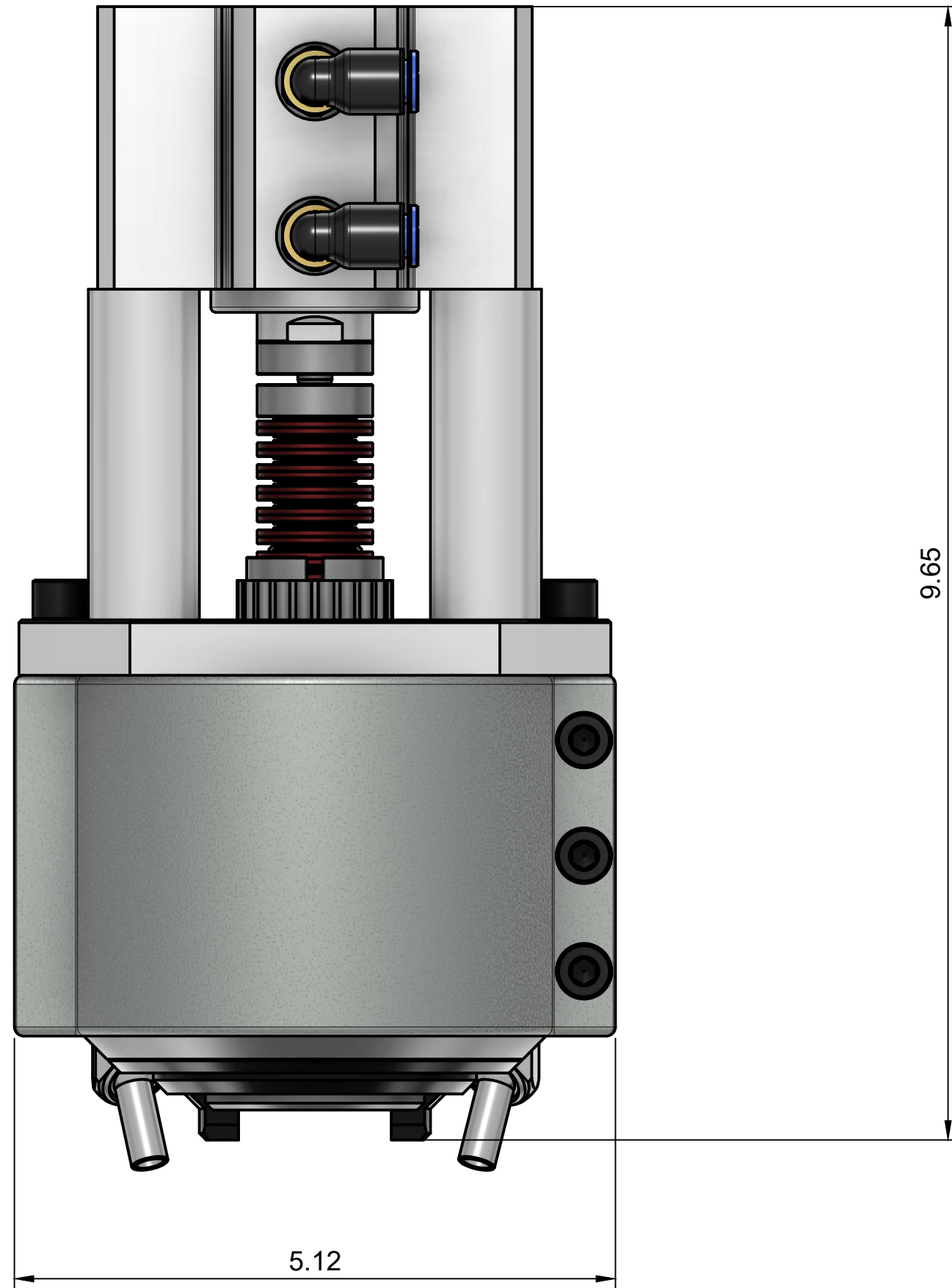

Metric

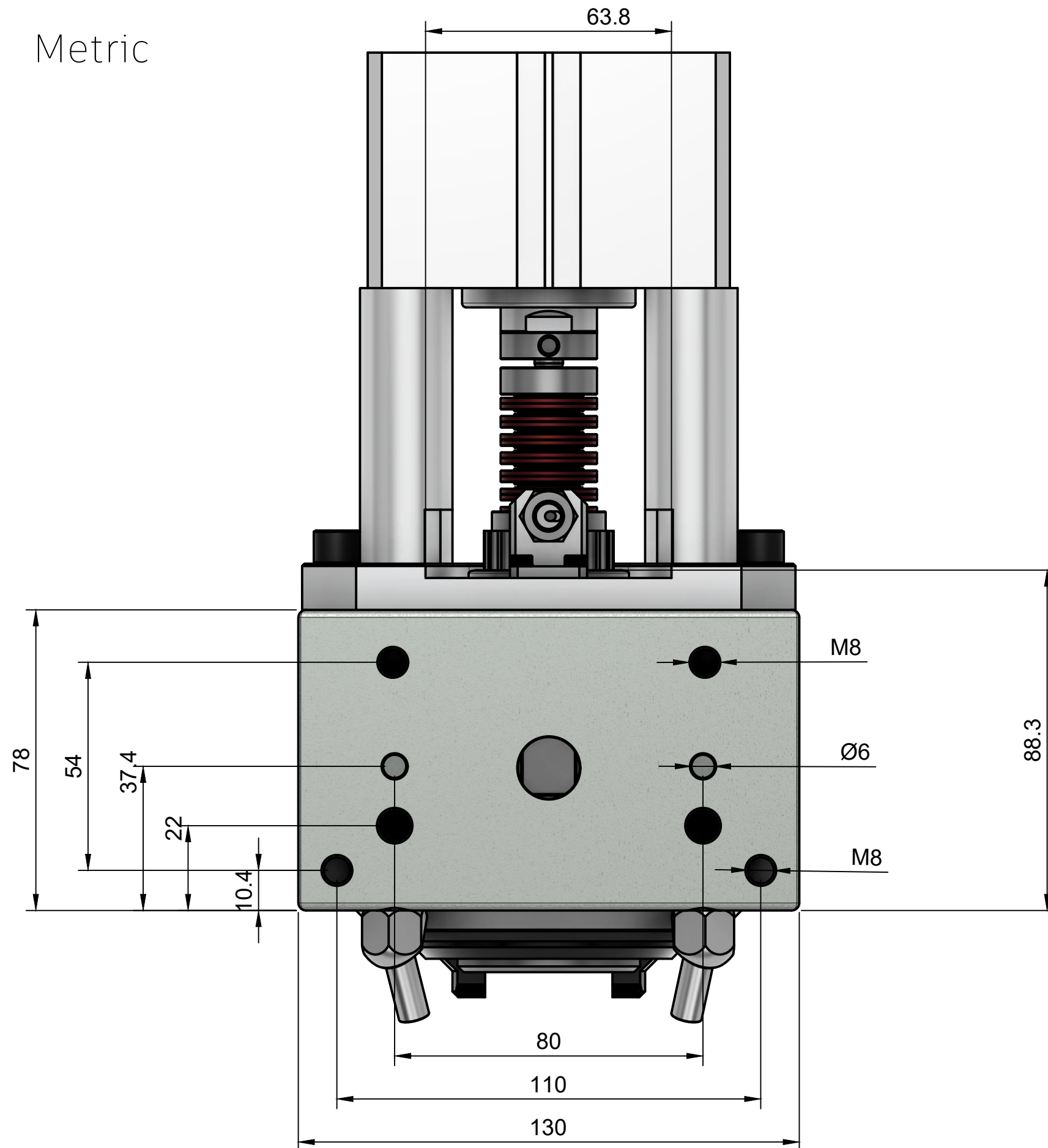

Imperial

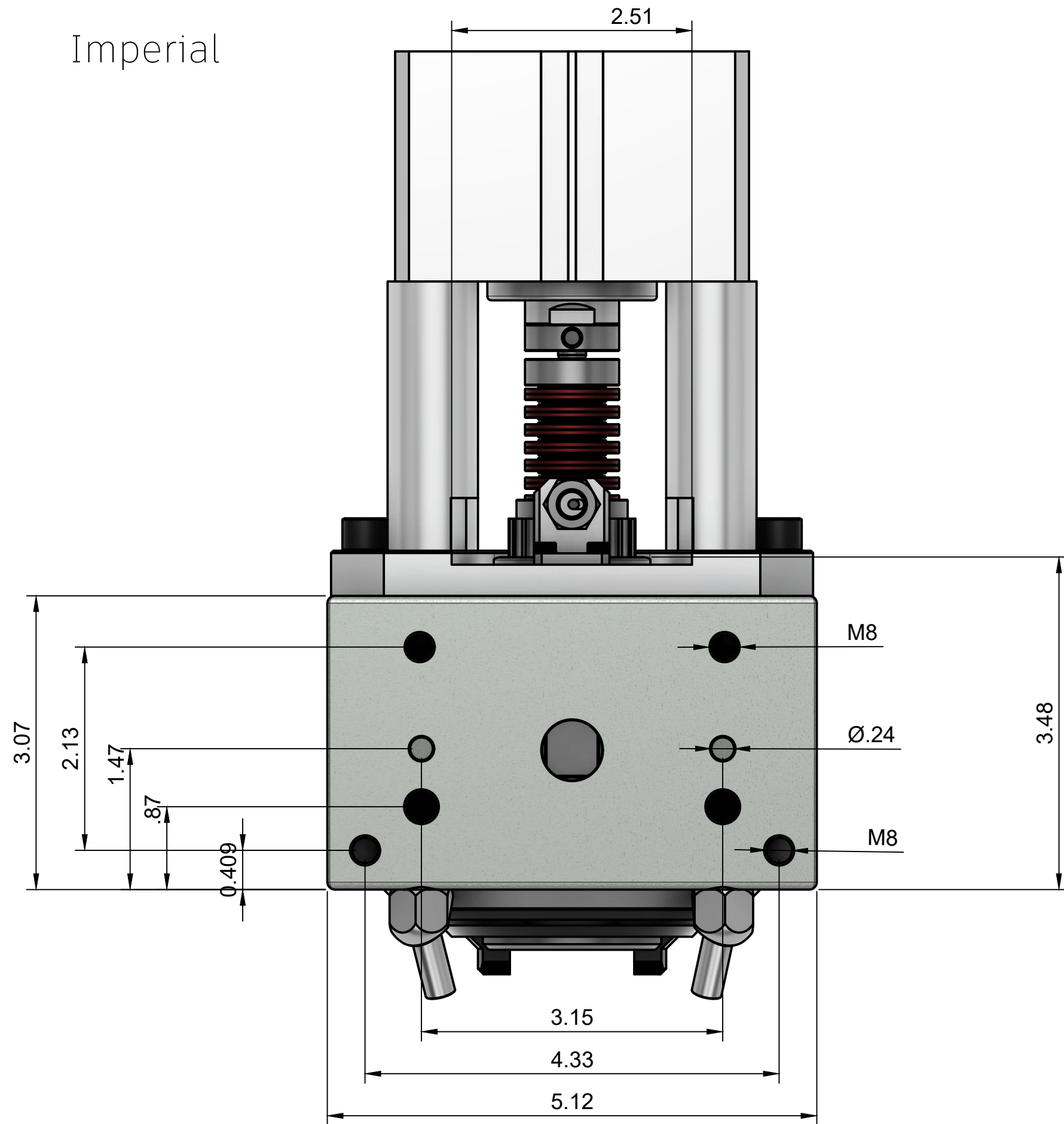

Metric

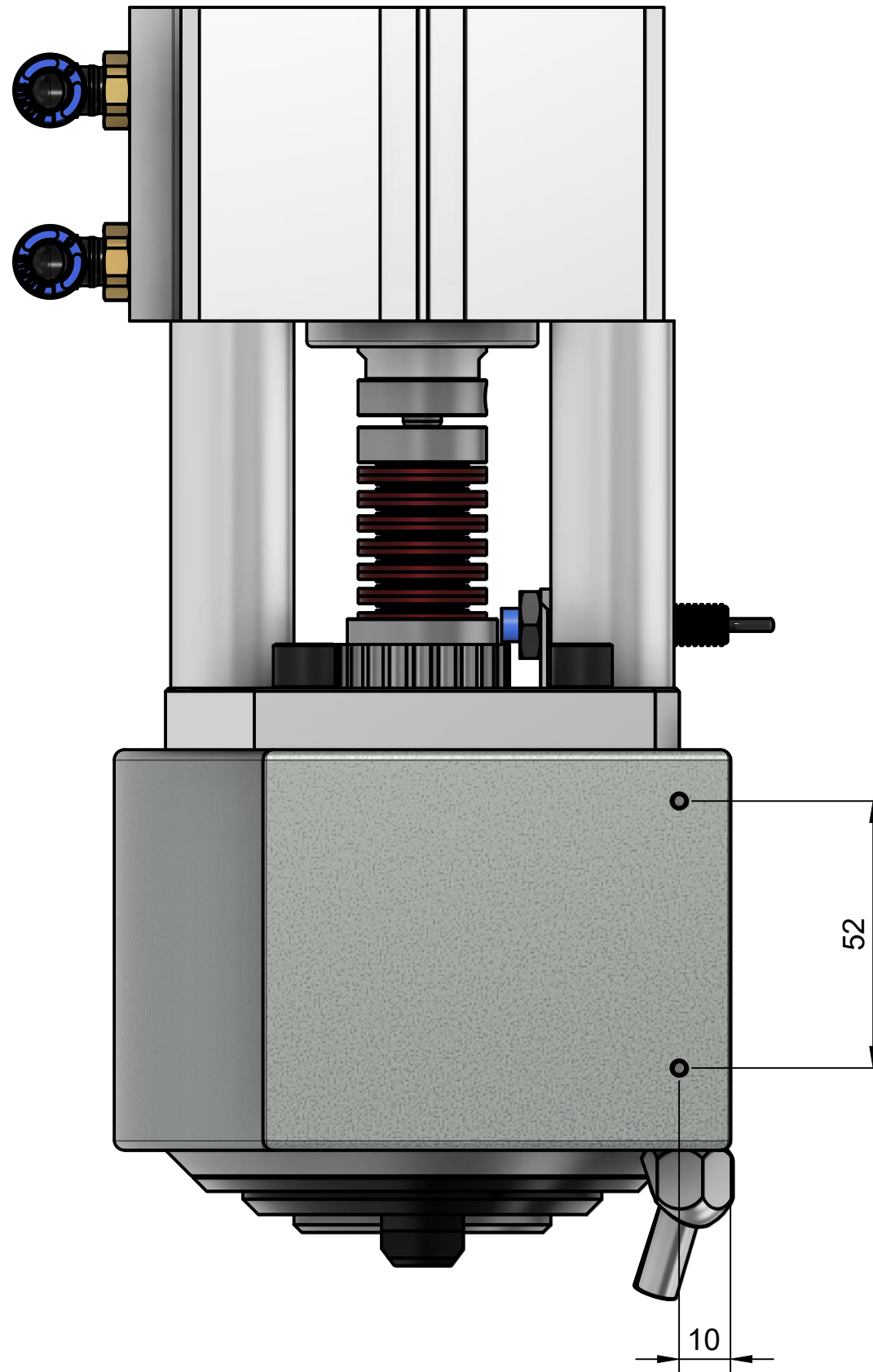

Imperial

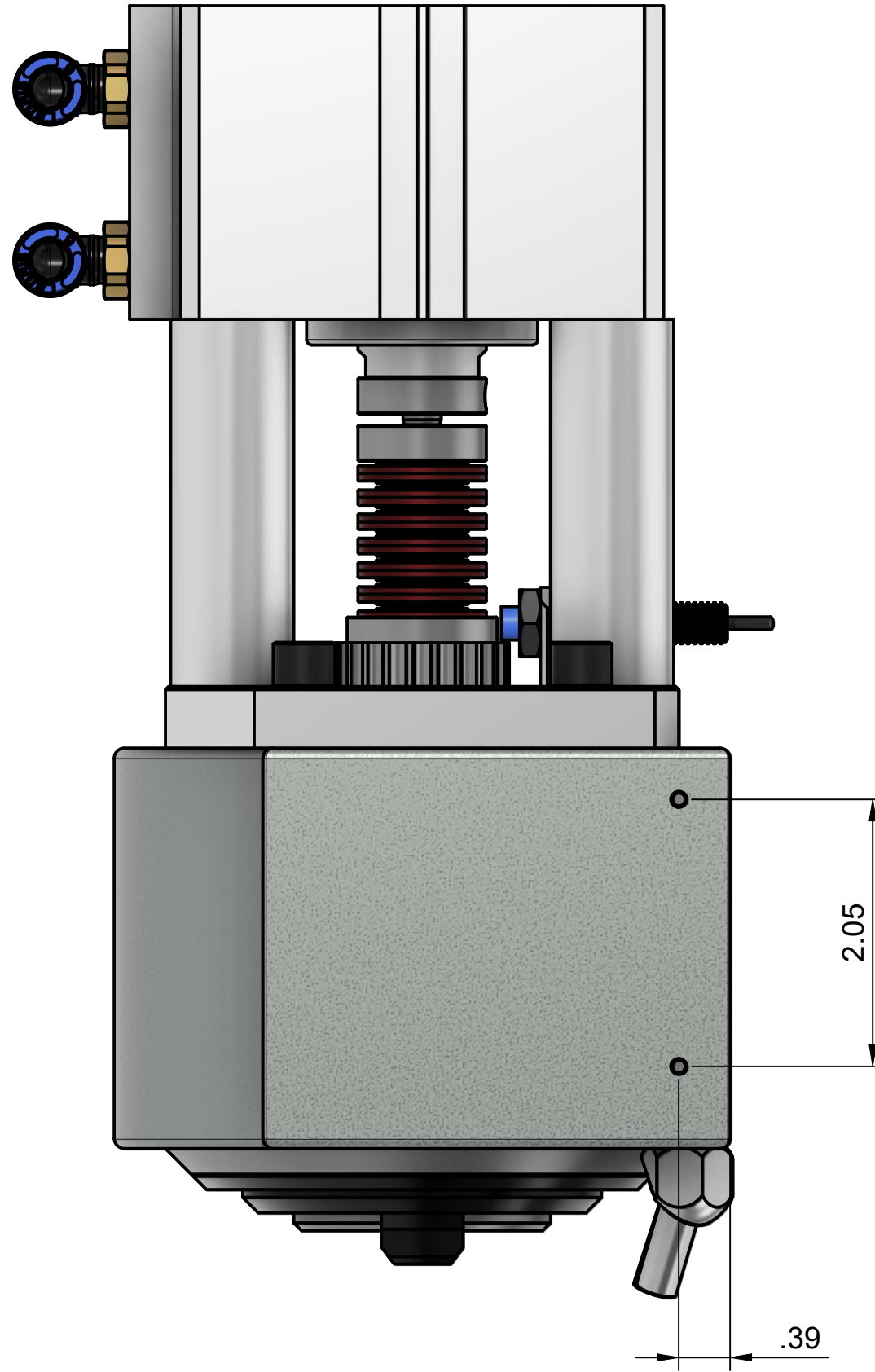

Metric

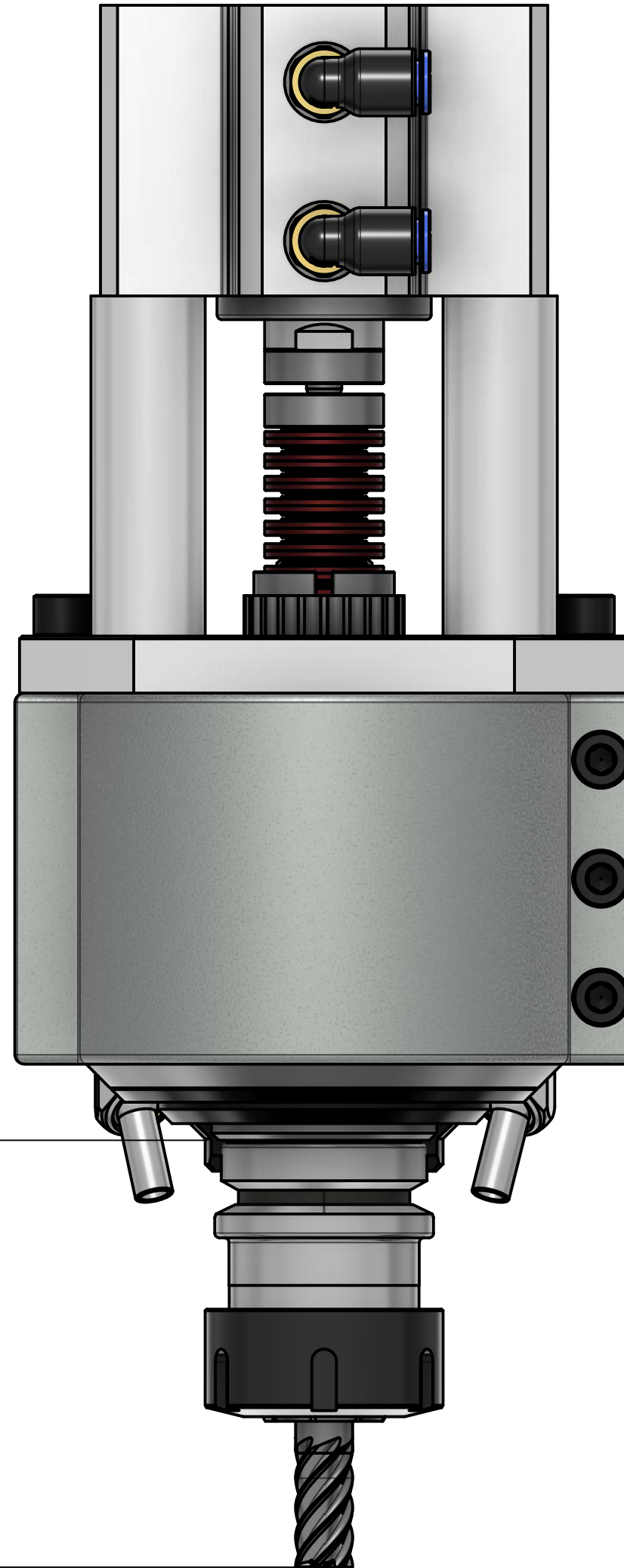

Maximum effective
tool stickout from
spindle nose

120

Imperial

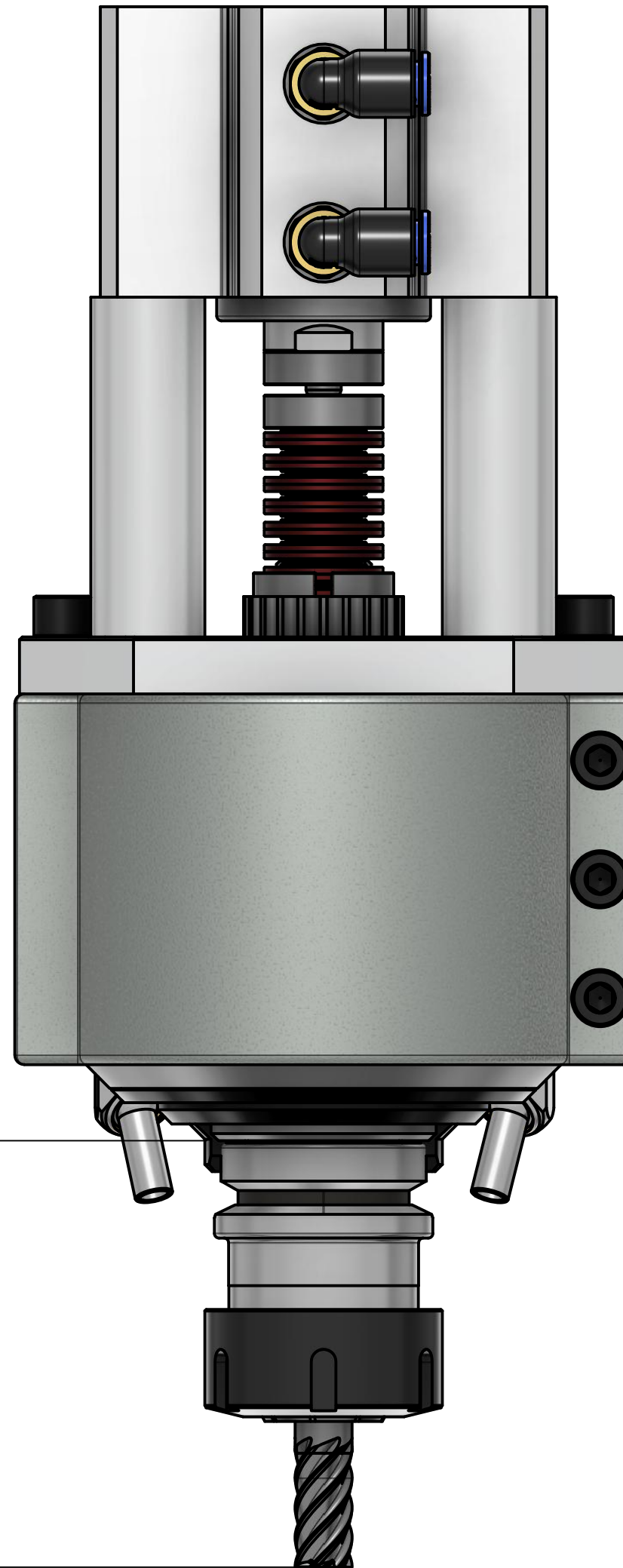

Maximum effective
tool stickout from
spindle nose

4.7