

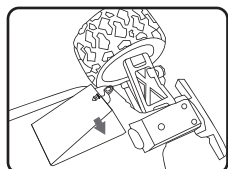

SETTING UP THE RIPPER

1. Turn off the power switch.
2. Using a phillips screwdriver open the battery compartment.
3. Connect the battery wire to The Ripper's connector as shown on the diagram.
4. Close the battery compartment and reinstall the screw.
5. Turn the power switch to On.

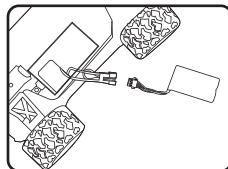
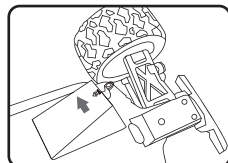
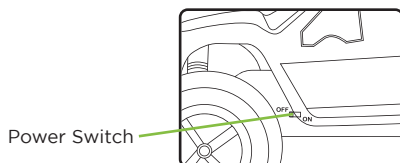

SETTING UP THE REMOTE CONTROL

1. Using a phillips screwdriver open the battery cover on the base of the controller.
2. Install 4x new AA batteries taking care to match the correct polarity (+/-).
3. Close the battery cover.

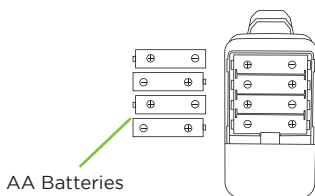

CHARGING THE RIPPER'S BATTERY

1. Remove the battery from The Ripper as shown in the setting up instructions.
2. Connect The Ripper's battery to the USB charging cord connector.
3. Plug the USB cord into a 5v1a USB charger.
4. The charger light will turn on to indicate charging. When the charger light goes out charging is complete and you can reinstall the battery in The Ripper.

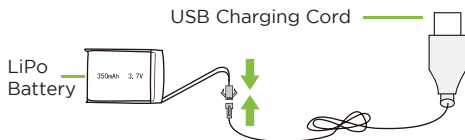

★Tip. Full charge takes up to 3-4hrs

OPERATING THE RIPPER

★ Tip. For best results the car needs to be within a 150 foot range of the controller.

Controller Functions

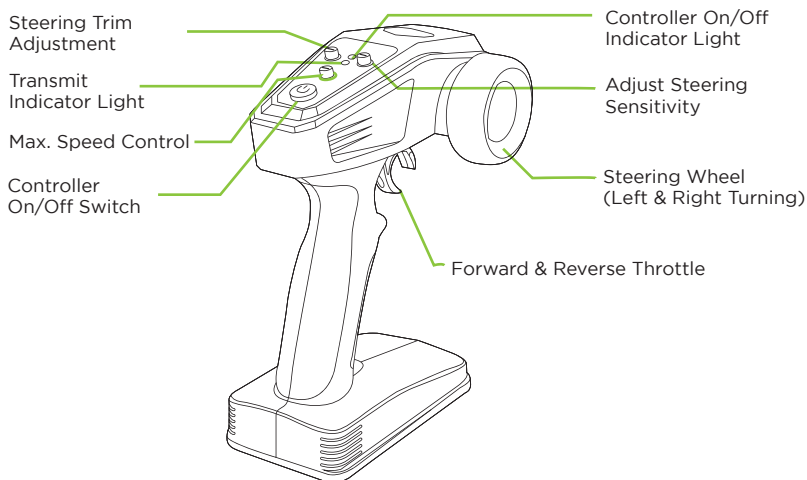

The Ripper Movement

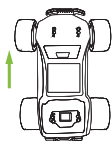
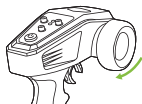

Forward: Pull down on the throttle to drive the vehicle forwards. Adjust the throttle position to control the speed of the vehicle.

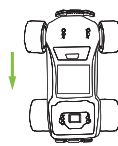
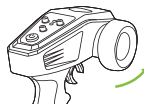

Reverse: Push up on the throttle to drive the vehicle in reverse. Adjust the throttle position to control the speed of the vehicle.

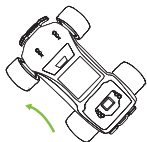
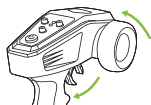

Forward & Turn Left: Pull down on the throttle while turning the steering wheel to the left.

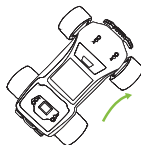
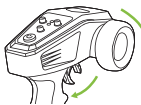

Forward & Turn Right: Pull down on the throttle while turning the steering wheel to the right.

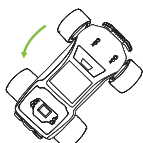
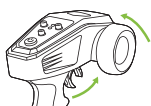

Reverse & Turn Left: Push up on the throttle while turning the steering wheel to the left.

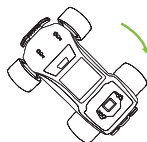
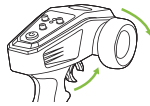

Reverse & Turn Right: Push up on the throttle while turning the steering wheel to the right.

The Ripper Steering Trim Adjustment

★ Tip. If The Ripper pulls to the left or right when driving forwards without steering from the controller, you should adjust the steering trim.

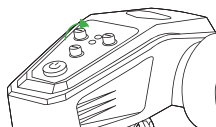

If the vehicle pulls to the left adjust the trim setting to the right until the vehicle travels in a straight line.

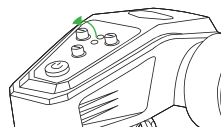

If the vehicle pulls to the right adjust the trim setting to the left until the vehicle travels in a straight line.

The Ripper Steering Sensitivity Adjustment

★ Tip. If The Ripper's steering is too sensitive for your driving style you can adjust the sensitivity.

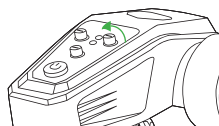

Turn the sensitivity control counter clockwise to decrease steering sensitivity.



Turn the sensitivity control clockwise to increase steering sensitivity.

The Ripper Max. Speed Control

★ Tip. If you find The Ripper's high speed hard to control you can limit the top speed with the Max. Speed Control.

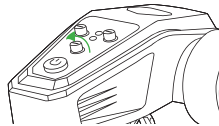

Turn the control counter clockwise to decrease maximum speed.

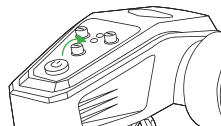

Turn the control clockwise to increase maximum speed.



For Customer Service please email:
Care@OdysseyToys.com

Please note the units model number and name in your email:
Model no. ODY-1030 • The Ripper

www.OdysseyToys.com

CAUTIONS & WARNINGS

- Suitable for ages 8 and up. Adult supervision is always recommended.
- This product contains small parts which are a choking hazard. Keep away from small children.
- Manufacturers and dealers disclaim all responsibility for damage caused by misuse.
- Keep hair and loose clothing away from the vehicle when powered on.
- If The Ripper will be stored and unused for an extended period of time, please remove the batteries.
- Check the batteries regularly for potential leakage or corrosion that may occur.
- When installing the batteries carefully follow the polarity marking +/-.
- Do not mix different battery types.
- Remove exhausted or drained batteries.
- Do not exceed charging volts and amps of 5v1a.
- Do not leave charger connected or charge for more than 1hr.

CARE & MAINTENANCE

- Do not submerge the unit in any liquids.
- Keep the unit dry.
- Do not place the unit near powerful, un-shielded magnets.
- Do not expose the unit to extreme hot or cold temperatures.
- Do not hit, drop, or smash the unit with extreme force.
- Do not disassemble the unit for any reason.

NOT FOLLOWING THESE PRECAUTIONS WILL VOID YOUR WARRANTY.

FCC STATEMENT: This product complies with Part 15 of the FCC Rules. Operation is subject to the following two conditions: (1) This device may not cause harmful interference and (2) this device must accept any interference receiver, including interference that may cause undesirable operation.

MADE IN CHINA

