

# FRONT INNER FENDER FLARES

————— User Manual —————

2018-2022 Wrangler JL

2019-2022 Jeep Gladiator JT



Model:	NJT01G101-F
Material:	Q235A
Product Dimensions:	38.5 x 12.7 x 20.5 inch
Package Dimensions:	30.3 x 26 x 11.8 inch
Product Weight:	44.09 lbs

---

※ Thank you for purchasing the FRONT INNER FENDERS. Please read this manual carefully and keep it properly if you need to refer to it afterward. If you need any support or assistance, please contact us with your product model number and order number, and our support team will help you solve problems.





**⚠ WARNING**

※ This product is designed primarily to enhance the appearance of the vehicle. Do not rely in any way on the components of this product to protect against injury or death in the event of an accident. To reduce the risk of serious injury or property damage, please read all safety messages and understand all instructions and procedure notices before attempting to install or use this product.







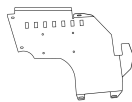
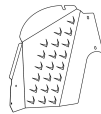

**⚠ CAUTION**

※ Properly torque and recheck fasteners and security of step tread after 250 miles and inspect frequently. Do not use if damaged.

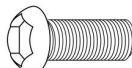
# REQUIRED TOOLS

<b>Socket</b> 	<b>Ratchet</b> 	<b>Allen Wrench</b> 	<b>Safety Glasses</b> 
--	---	--	--

## Parts Information

Parts NO.	Parts Name	Size	Line Graph	Qty	Color
/	Front Inner Fender Flares 1	/		2	Black
/	Front Inner Fender Flares 2	/		2	Black
N09	Hex Flange Nuts	M6		12	Dacro Black
B07	Half Head Allen Bolts	M6 x 20		12	Dacro Black
W09	Spring Washer	Φ6		12	Dacro Black
W11	Flat Washer	Φ6x12x1.5		12	Dacro Black
S07	Plastic Screw	Φ7 x 20		6	PA
S06	Clips 1	Φ7 x 13.5		4	PA
S08	Clips 2	Φ9 x 12.5		4	PA

**\*Note: spare parts such as N09、B07、W09、W11、S07、S06、S08 are provided with 2PCS each (included in the number of parts details).**

# Installation Instructions

**Step 1:** Open the carton and take out the parts. Check whether the number of components is complete.

**Step 2:** Remove the original front fender flares and original front inner fender flares and prepare the parts needed to install the Front Inner Fender Flares.

**Step 3:** Splice the front inner fender flares.

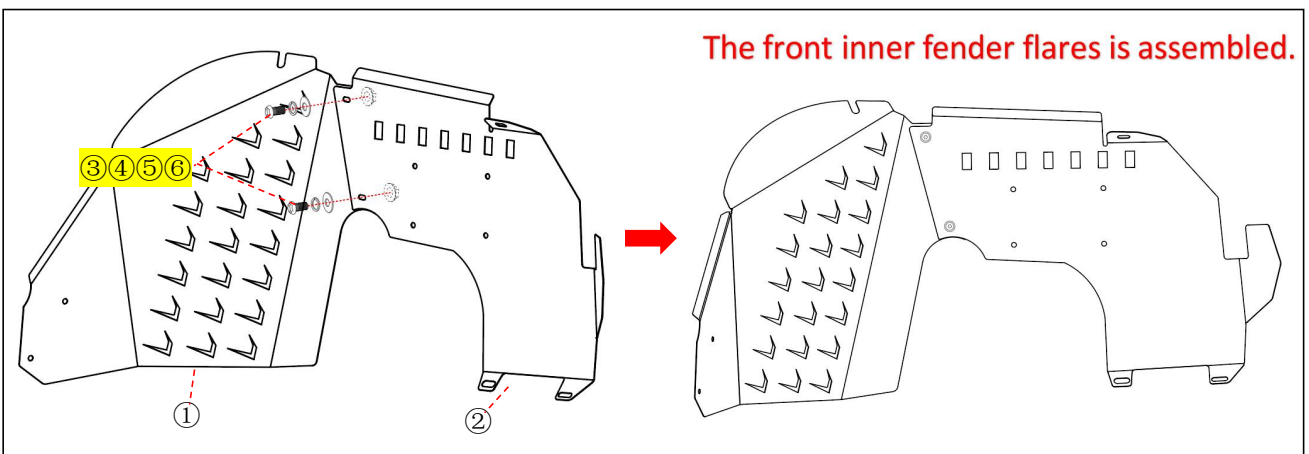
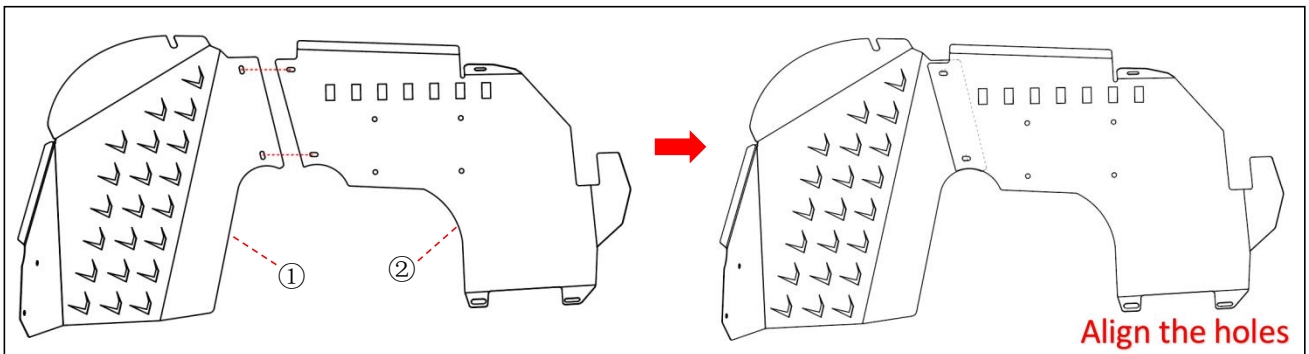
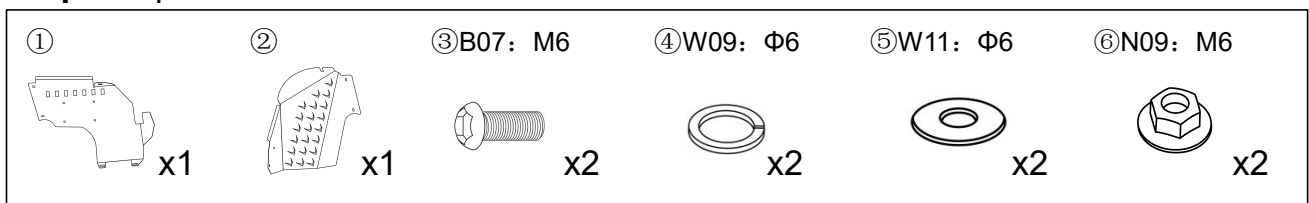

**Step 4: Install the front inner fender flares.**

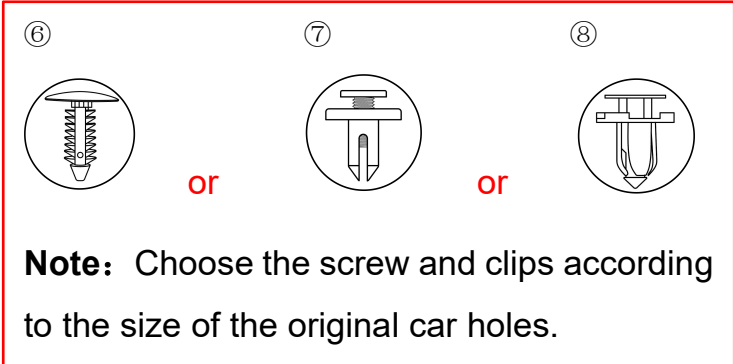
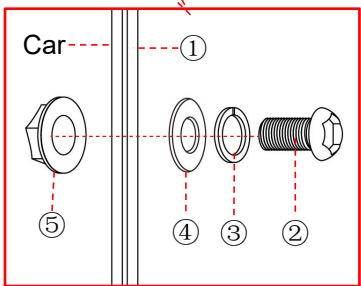
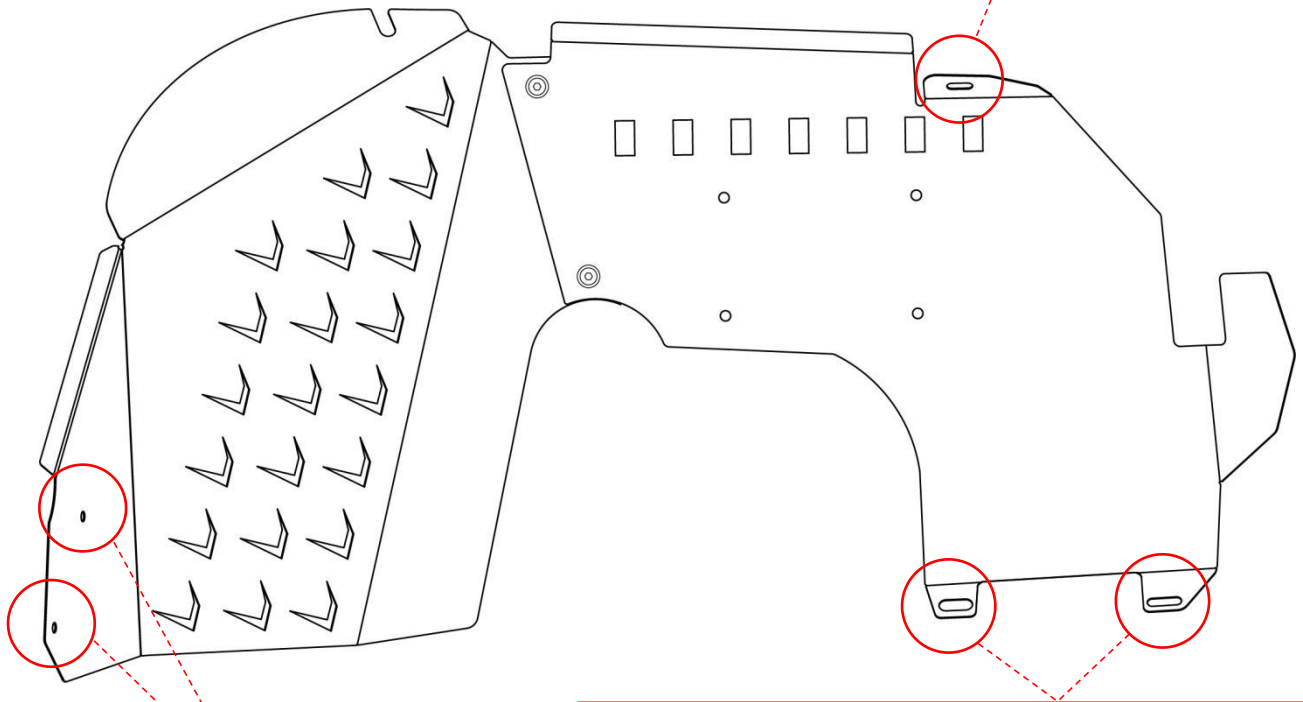
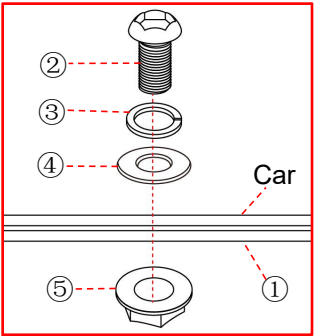
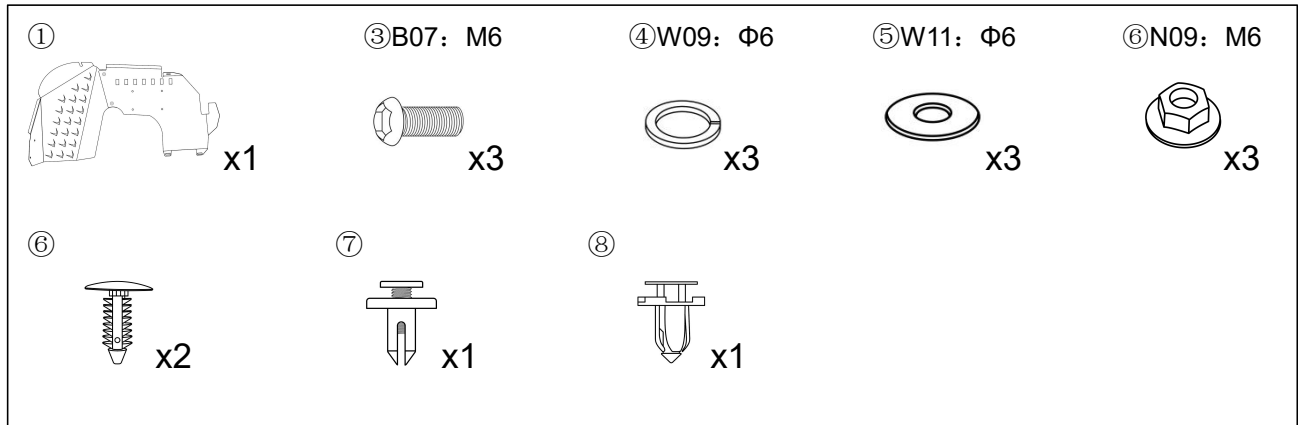

**Step 5:** Tighten all the bolts and nuts.

**Step 6:** Installation of a front inner fender flares is complete. Please do periodic inspections of the inner fender flares to make sure that all hardware is secure and tight.

**Step 7:** Install the original front fender flares.



# REAR INNER FENDER FLARES

————— User Manual —————

2018-2022 Wrangler JL

2019-2022 Jeep Gladiator JT



Model:	NJT01G101-R
Material:	Q235A
Product Dimensions:	40.9 x 9.5 x 12.6 inch
Package Dimensions:	28 x 24 x 8.7 inch
Product Weight:	18.52 lbs

---

※ Thank you for purchasing the REAR INNER FENDERS. Please read this manual carefully and keep it properly if you need to refer to it afterward. If you need any support or assistance, please contact us with your product model number and order number, and our support team will help you solve problems.

**⚠ WARNING**





※ This product is designed primarily to enhance the appearance of the vehicle. Do not rely in any way on the components of this product to protect against injury or death in the event of an accident. To reduce the risk of serious injury or property damage, please read all safety messages and understand all instructions and procedure notices before attempting to install or use this product.

**⚠ CAUTION**







※ Properly torque and recheck fasteners and security of step tread after 250 miles and inspect frequently. Do not use if damaged.

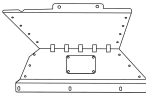

# REQUIRED TOOLS

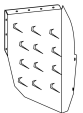
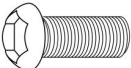
<b>Socket</b> 	<b>Ratchet</b> 	<b>Allen Wrench</b> 	<b>Safety Glasses</b> 
--	---	--	--

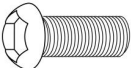
## Parts Information

Parts NO.	Parts Name	Size	Line Graph	Qty	Color
/	Rear Inner Fender Flares 1	/		2	Black
/	Rear Inner Fender Flares 2	/		2	Black
/	Rear Inner Fender Flares 3	/		2	Black
B05	Half Head Allen Bolts	M6 x 10		30	Dacro Black
N09	Hex Flange Nuts	M6		38	Dacro Black
B07	Half Head Allen Bolts	M6 x 20		22	Dacro Black
W09	Spring Washer	Φ6		22	Dacro Black
W11	Flat Washer	Φ6x12x1.5		22	Dacro Black

**\*Note: spare parts such as B05、N09、B07、W09、W11 are provided with 2PCS each (included in the number of parts details).**

# Installation Instructions

**Step 1:** Open the carton and take out the parts. Check whether the number of components is complete.

**Step 2:** Remove the original rear fender flares and original rear inner fender flares and prepare the parts needed to install the Rear Inner Fender Flares.

**Step 3:** Splice the rear inner fender flares.

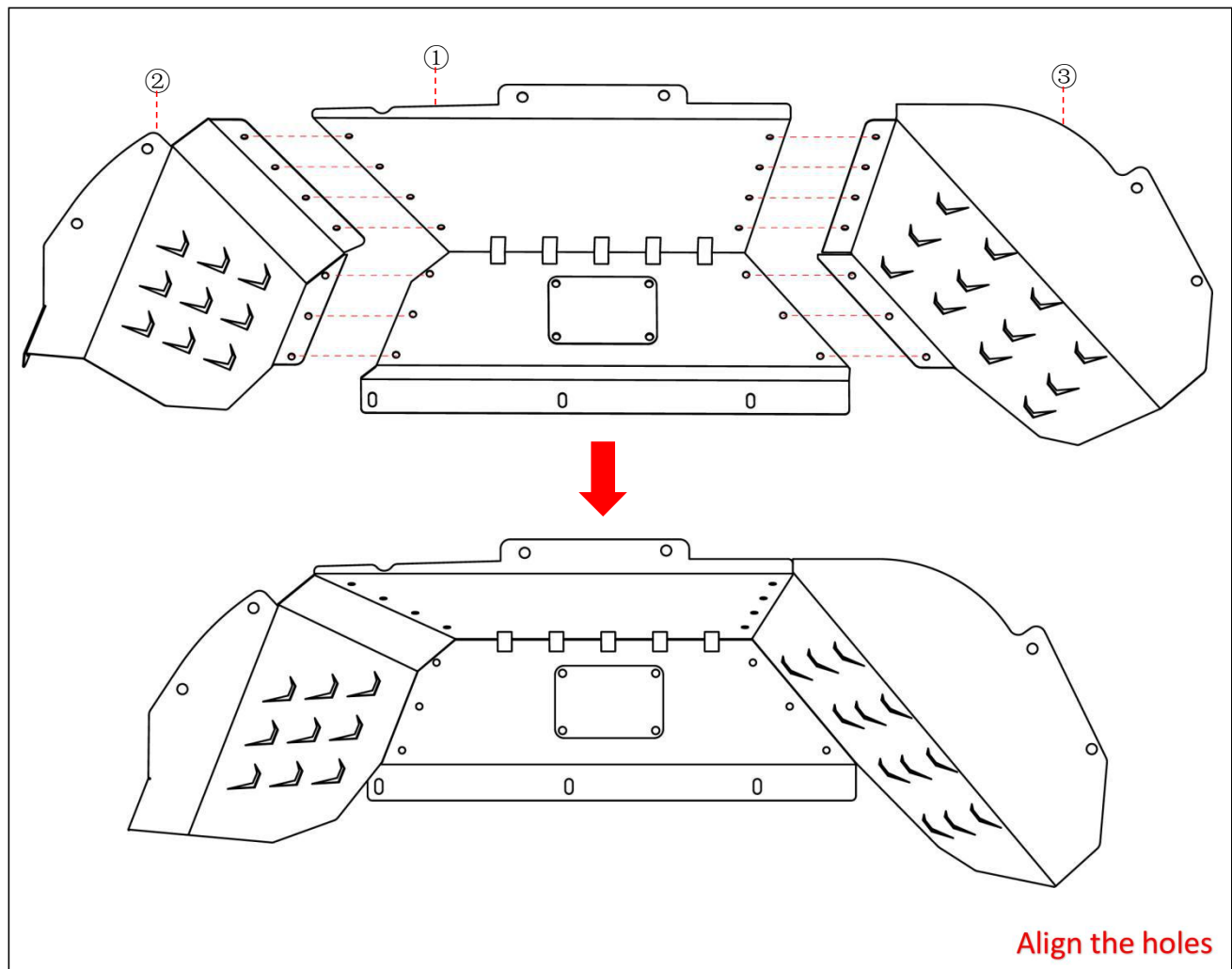
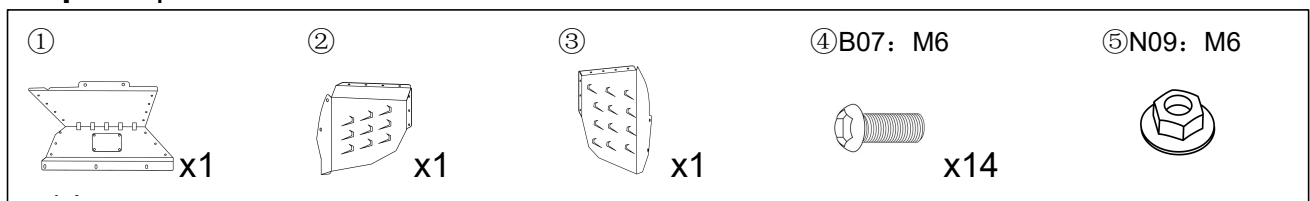

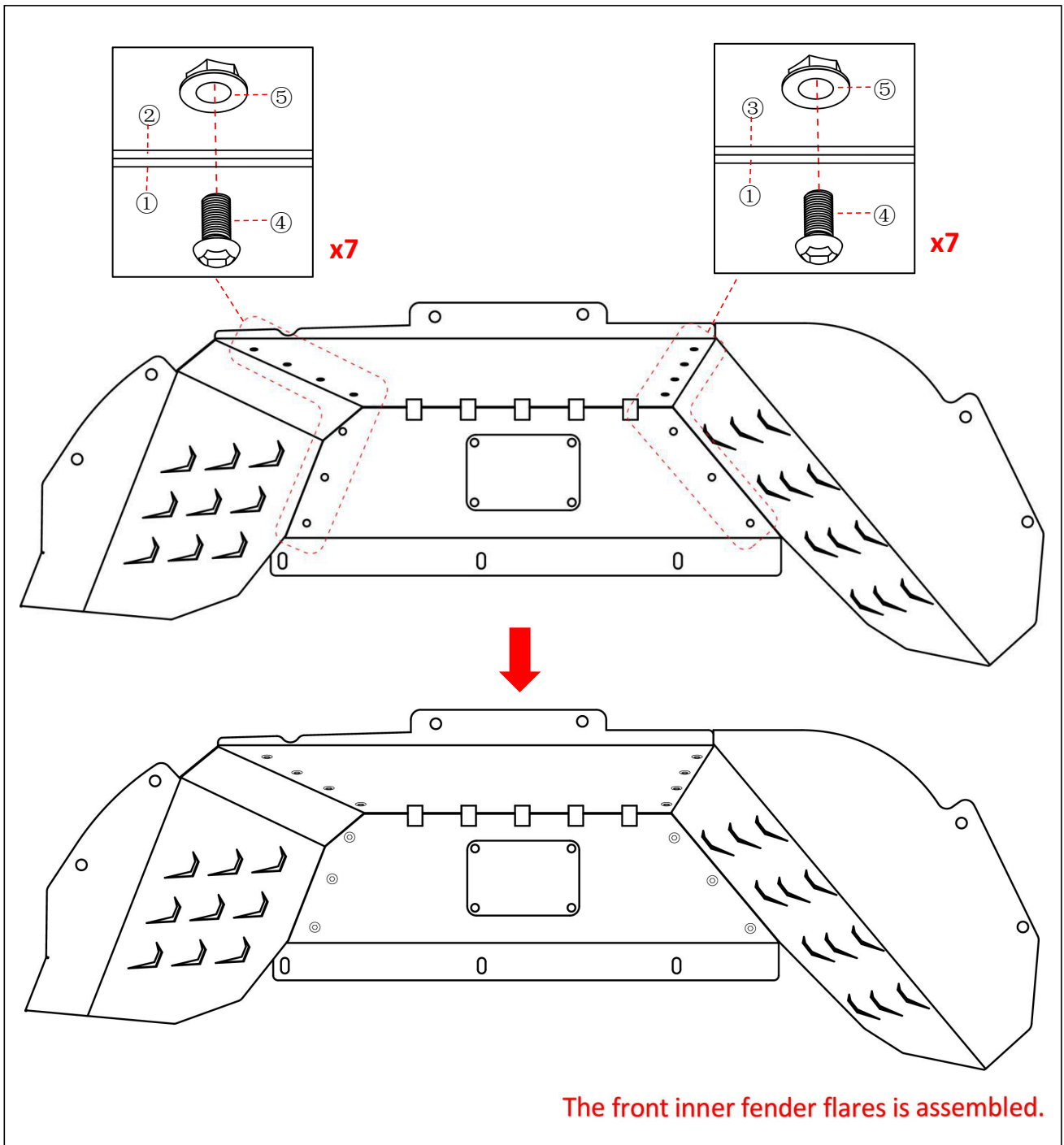

**Step 4: Install the rear inner fender flares.**

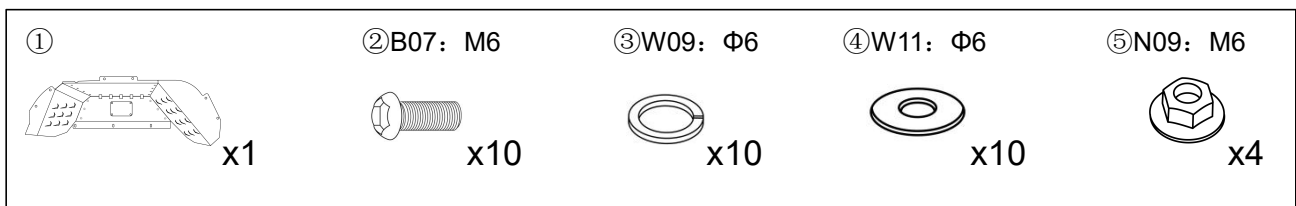

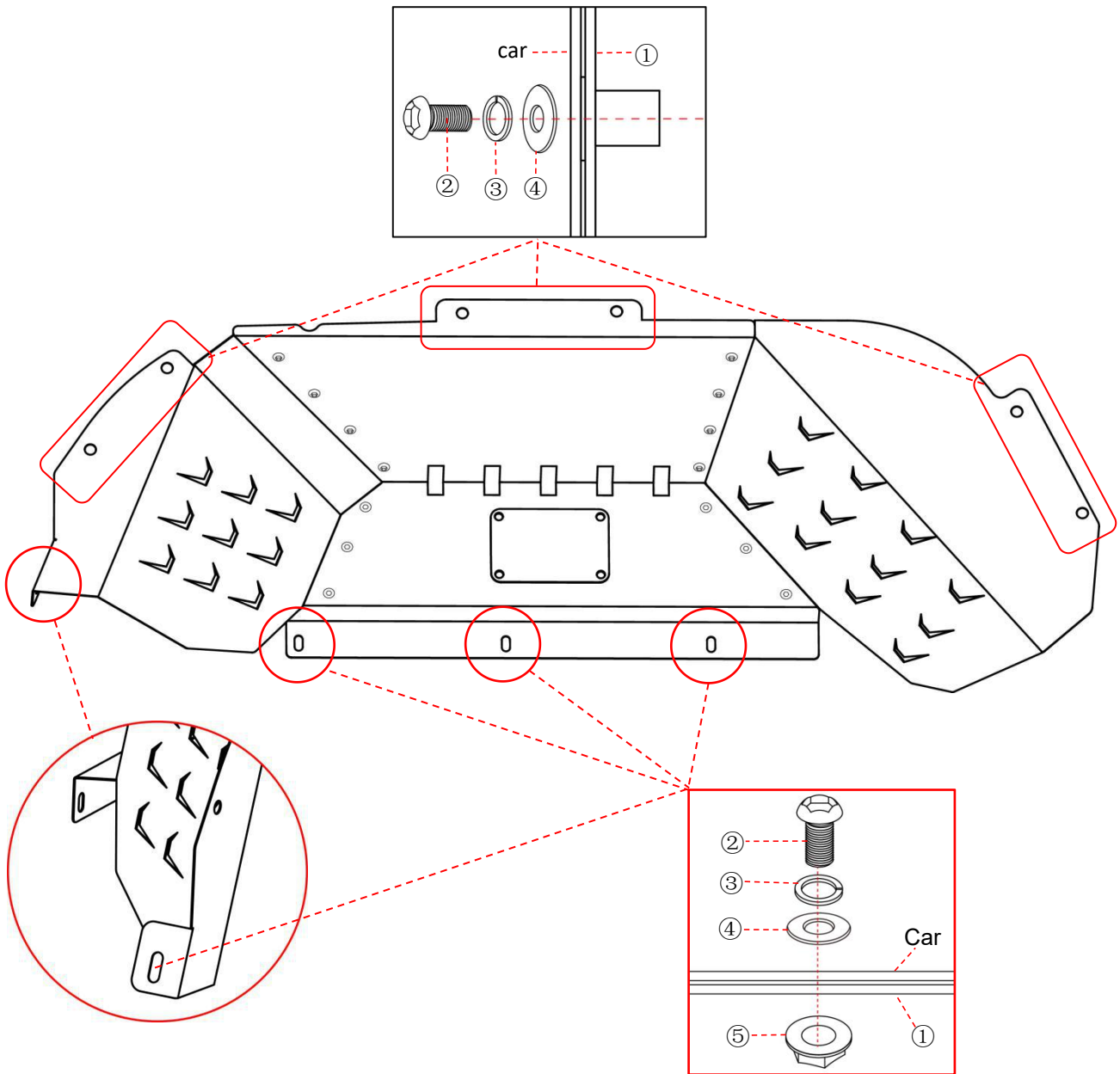

**Step 5:** Tighten all the bolts and nuts.

**Step 6:** Installation of a rear inner fender flares is complete. Please do periodic inspections of the inner fender flares to make sure that all hardware is secure and tight.

**Step 7:** Install the original rear fender flares.