

# FRONT BUMPER

————— User Manual —————

2021-2023 Ford Bronco(not Bronco Sport)

**NFB01A105-1A**



**NFB01A105-1B**



Model:	NFB01A105-1A /NFB01A105-1B
Material:	Q235A
Product Dimensions:	43 x 7.24 x 8.59 inch
Package Dimensions:	46.26 x 10.43 x 10.23 inch
Product Weight:	45.74 lbs

---





※ Thank you for purchasing the FRONT BUMPER. Please read this manual carefully and keep it properly if you need to refer to it afterward. If you need any support or assistance, please contact us with your product model number and order number, and our support team will help you solve problems.

**⚠ WARNING**





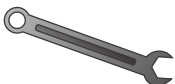





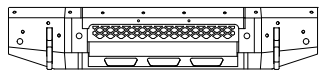
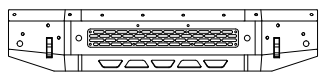
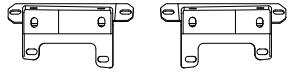
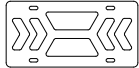

※ This product is designed primarily to enhance the appearance of the vehicle. Do not rely in any way on the components of this product to protect against injury or death in the event of an accident. To reduce the risk of serious injury or property damage, please read all safety messages and understand all instructions and procedure notices before attempting to install or use this product.

**⚠ CAUTION**

※ Properly torque and recheck fasteners and security of step tread after 250 miles and inspect frequently. Do not use if damaged.

REQUIRED TOOLS				
Socket 	Ratchet 	Wrench 	Allen Wrench 	Safety Glasses 

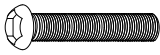
# Parts Information

	NO.	Parts Name	Size	Line Graph	Qty	Color
①	1A	Bumper	/	 or 	1	Black
	1B					
②	/	Bull Bar Barrect	/		1	Black
③	/	License Plate Holder	/		1	Black
④	B07	Half Head Allen Bolts	M6x20		3	Dacro Black
⑤	N09	Hex Flange Nuts	M6		3	Dacro Black
⑥	W13	Flat Washer	Φ6x18x1		3	Dacro Black
⑦	B43	Square Neck Bolt	M10x35		7	Blue Zinc Plating
⑧	W33	Flat Washer	Φ10x25x2		7	Blue Zinc Plating
⑨	W32	Spring Washer	Φ10		7	Blue Zinc Plating
⑩	N26	Hex Nuts	M10		7	Blue Zinc Plating
⑪	W21	Plastic Plate	M10		7	Blue Zinc Plating
⑫	B12	Half Head Allen Bolts	M8x16		17	Dacro Black
⑬	N14	Hex Flange Nuts	M8		17	Dacro Black
⑭	B46	Half Head Allen Bolts	M6x40		5	Dacro Black
⑮	N11	Lock Nuts	M6		5	Dacro Black

※ Note: spare parts such as B07、N09、W13、B43、W33、W32、N26、W21、B12、N14、B46 and N11 are provided with 1PCS each (included in the number of parts details).

# Installation Instructions

※ **Note:** This installation manual takes one of the models as an example.

Step 1: Open the carton and take out the parts. Check whether the number of components is complete.

Step 2: Remove the original bumper and prepare the parts needed to install the bumper.

Step 3: Install the Radar Probe.



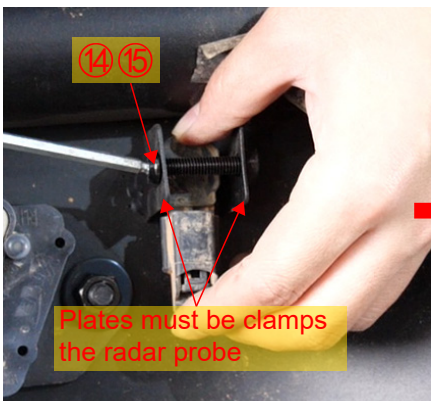
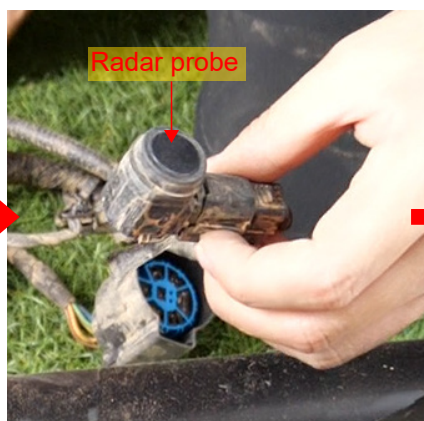
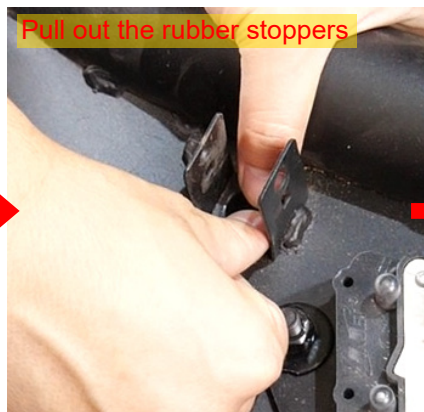
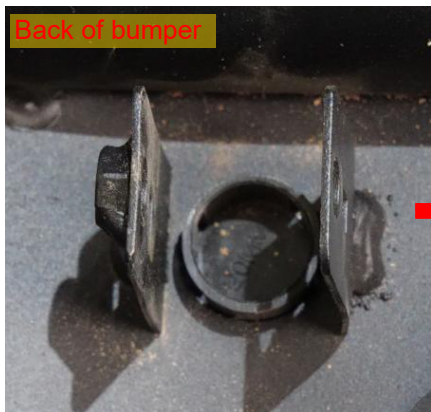

**Note:** If the car does not have a radar probe, this step can be ignored.

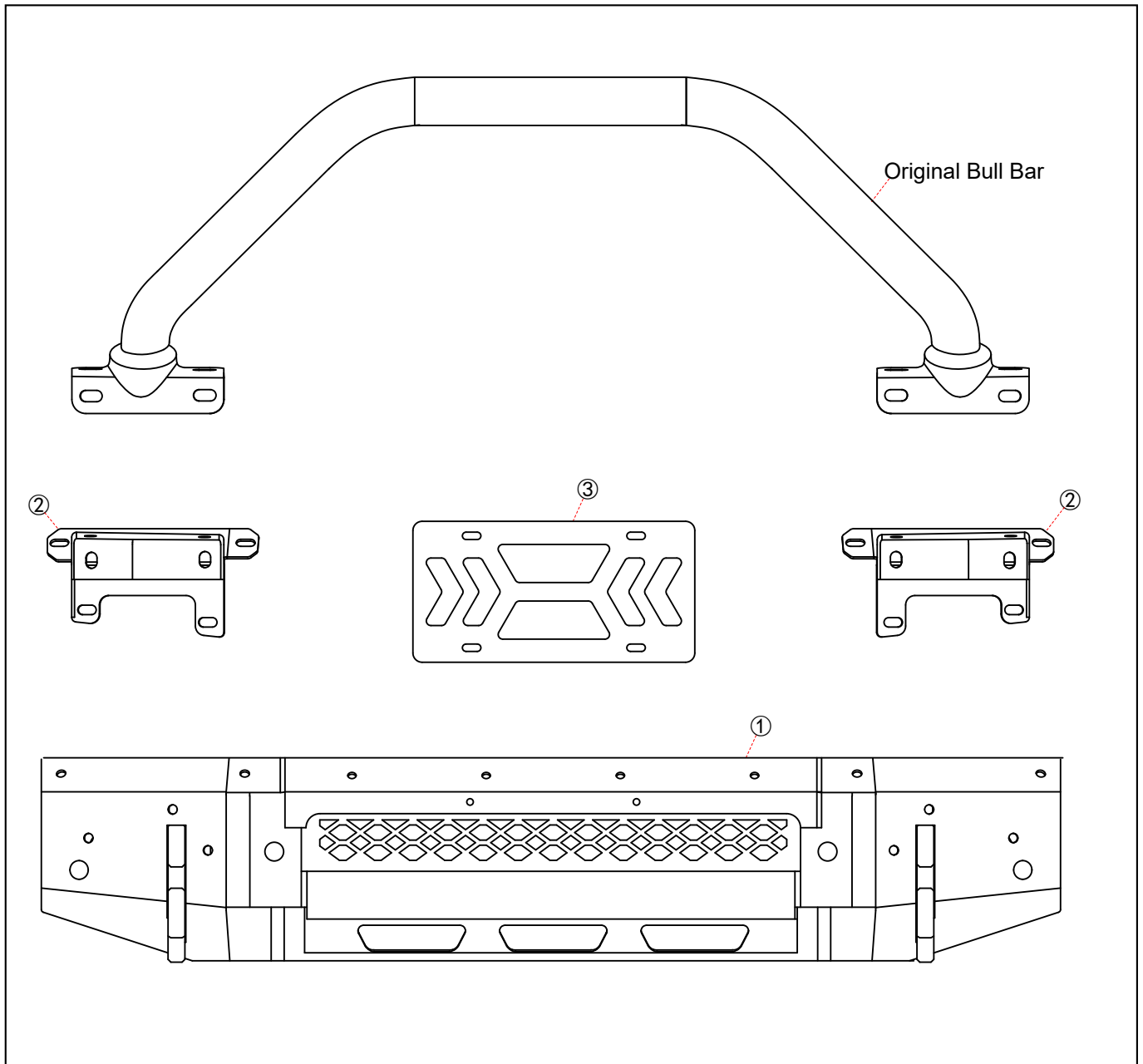

Step 4: Splicing the Bumper.

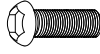
Note: There are two options for the front bumper installation, choose one according to your personal preference.

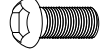

④	B07	Half Head Allen Bolts	M6x20		2
⑤	N09	Hex Flange Nuts	M6		2
⑥	W13	Flat Washer	Φ6x18x1		2
⑫	B12	Half Head Allen Bolts	M8x16		16
⑬	N14	Hex Flange Nuts	M8		16

# Option 1.

※ **Note:** The bolts here are used for decoration and can be installed or not according to personal preference.

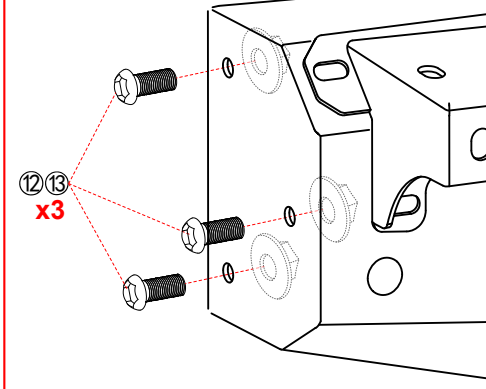

※ **Note:** The bolts here are used for decoration and can be installed or not according to personal preference.

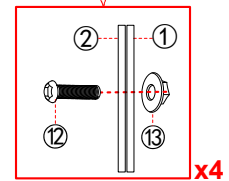
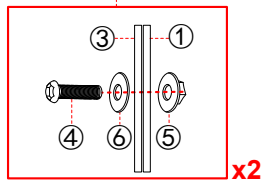
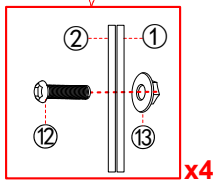
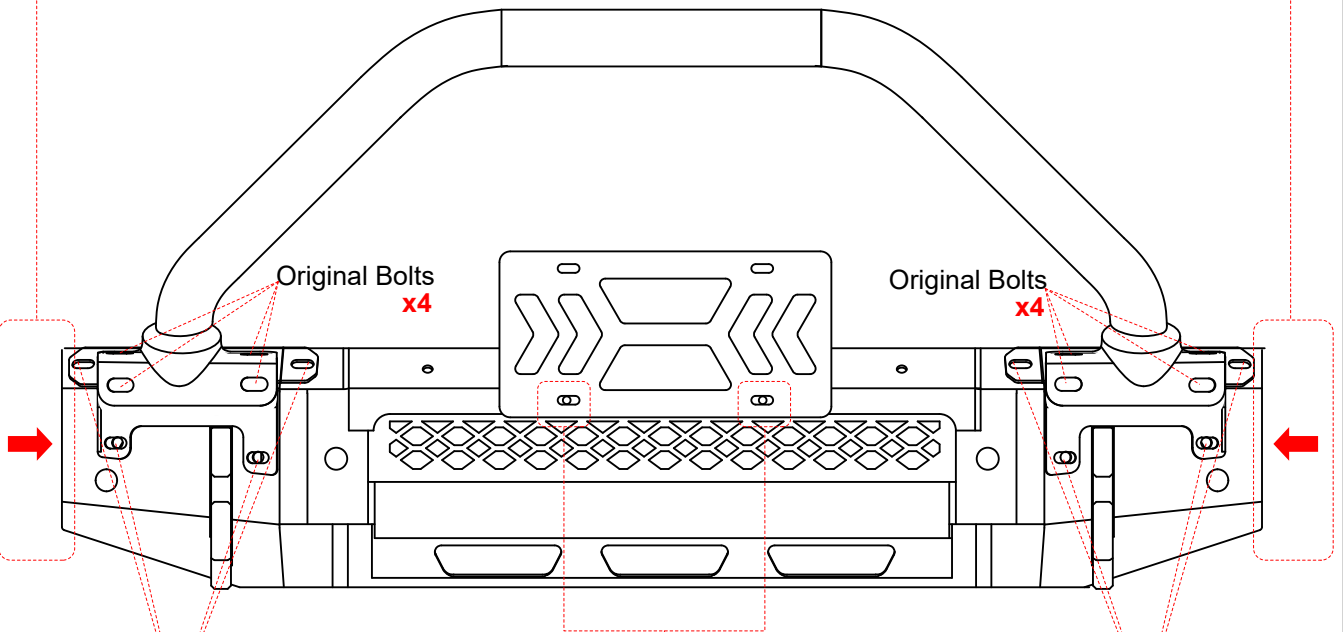
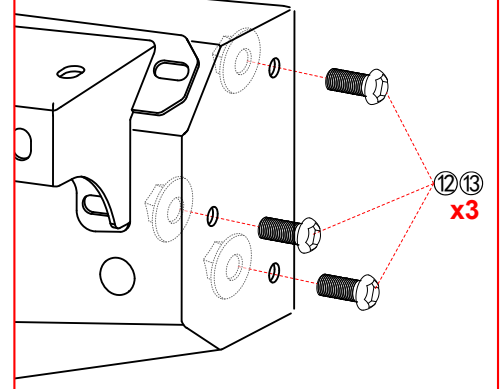

## Option 2.

※ **Note:** The bolts here are used for decoration and can be installed or not according to personal preference.

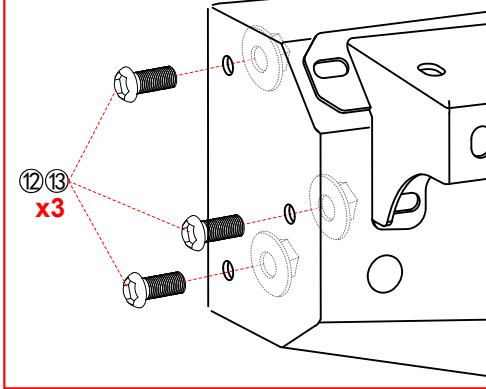

※ **Note:** The bolts here are used for decoration and can be installed or not according to personal preference.

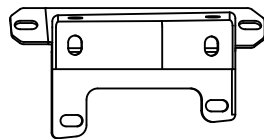
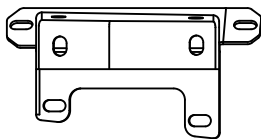
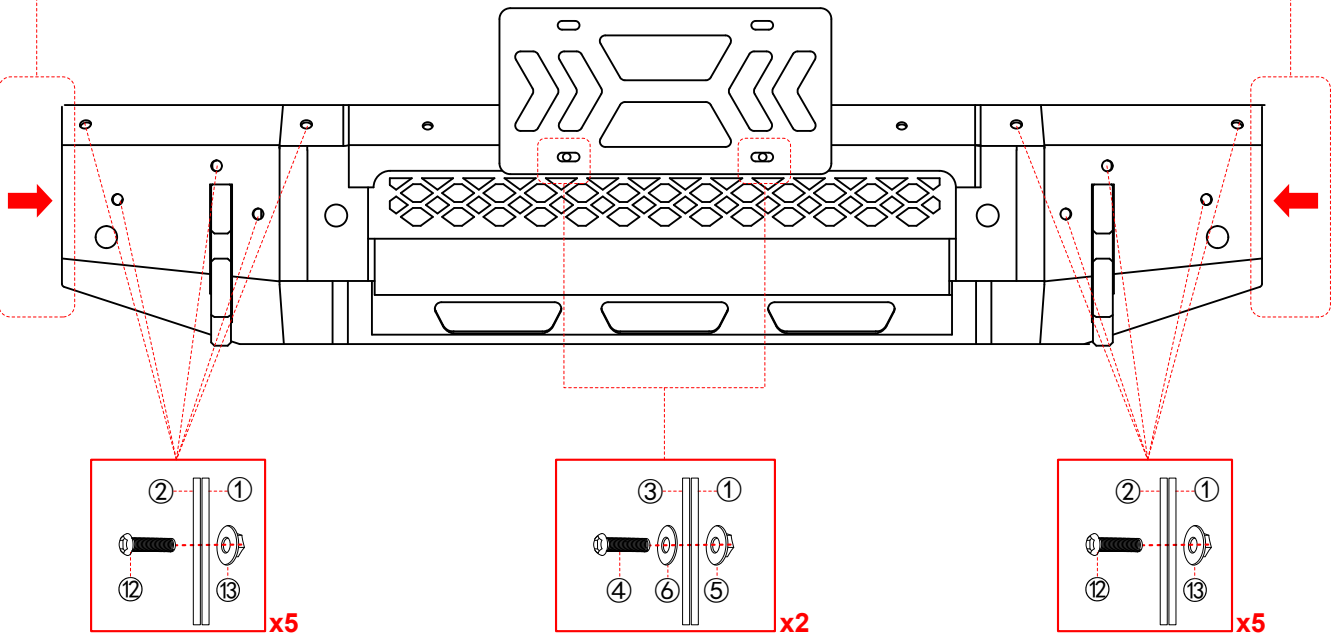
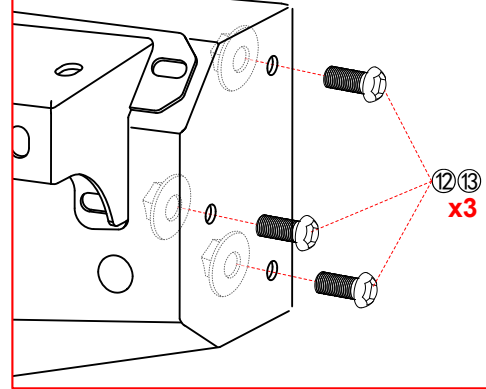

※ **Note:** Please keep the Bull Bar Barcket properly. The Bull Bar is equipped with a Barcket. In case you need to install an Bull Bar.

## Step 5: Install the Bumper.

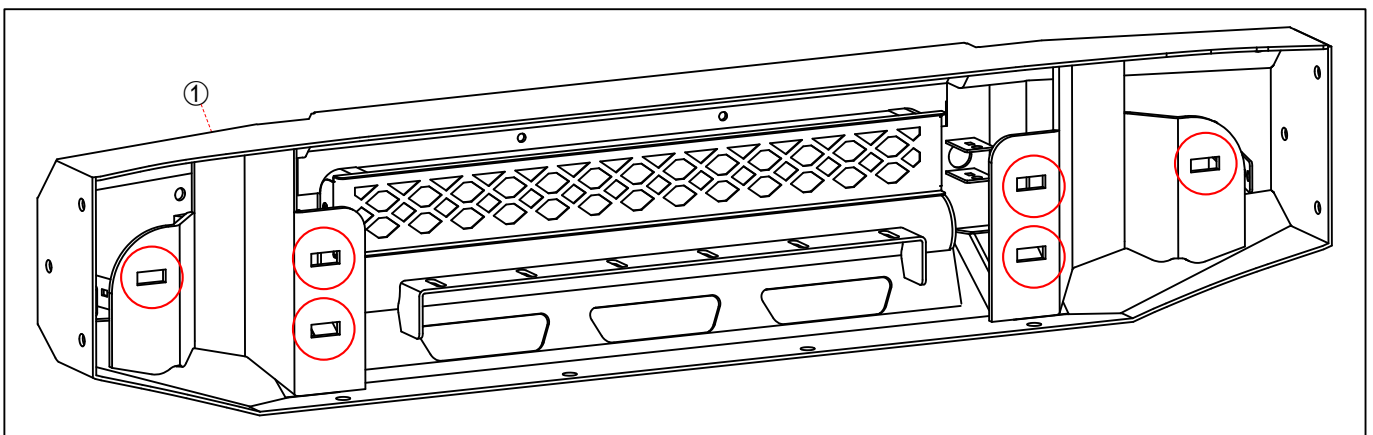

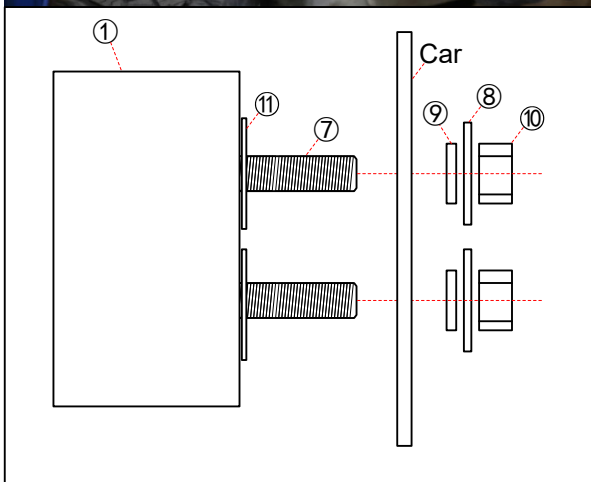
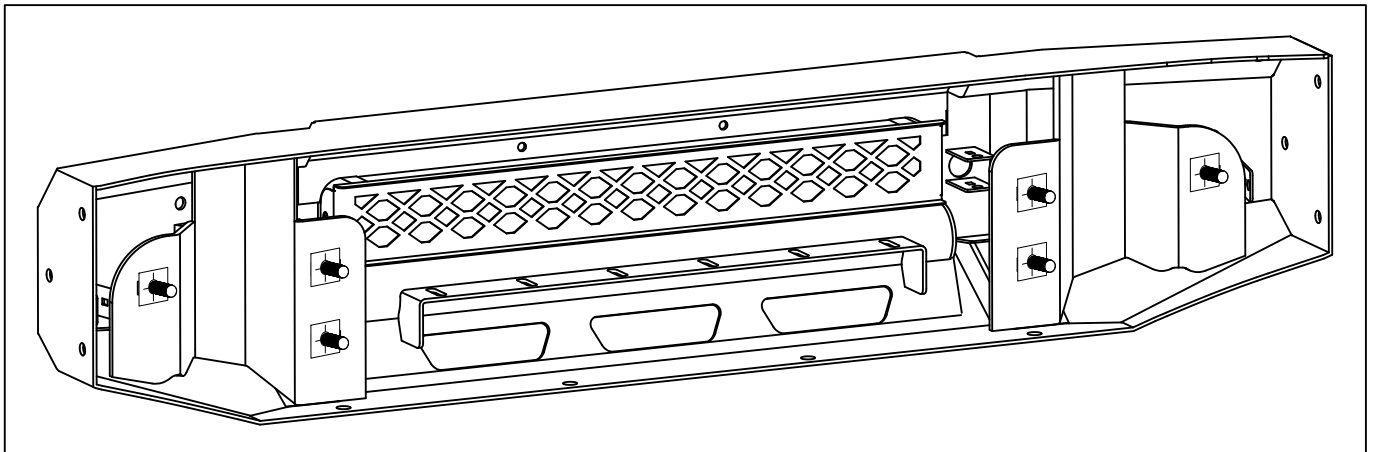
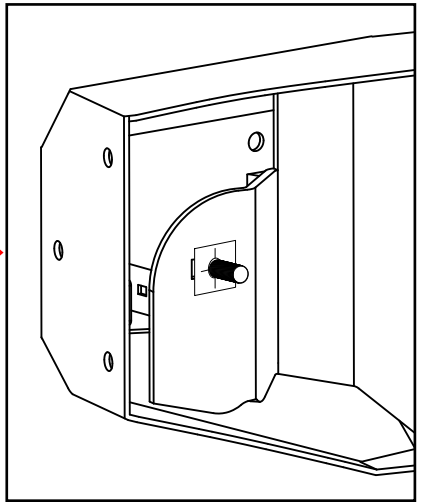
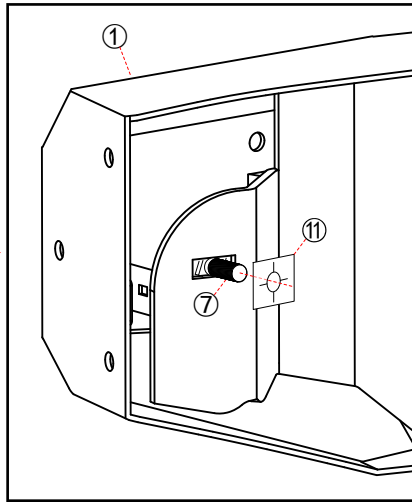
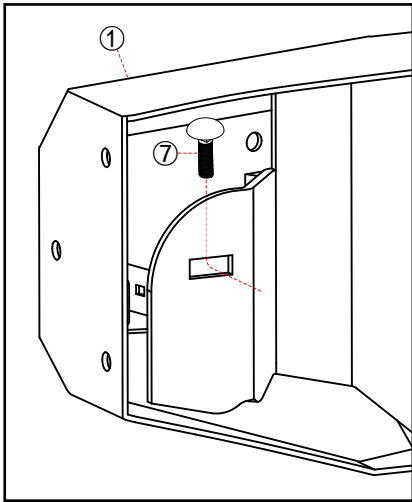



**The Front Bumper is installed.**

Option 1.

**NFB01A105-1A**

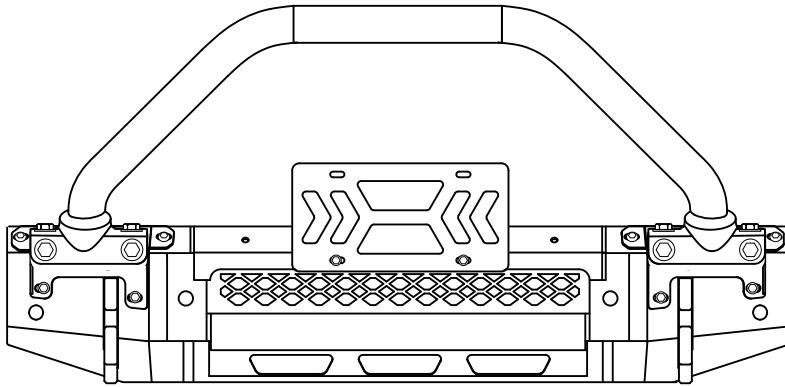

**NFB01A105-1B**

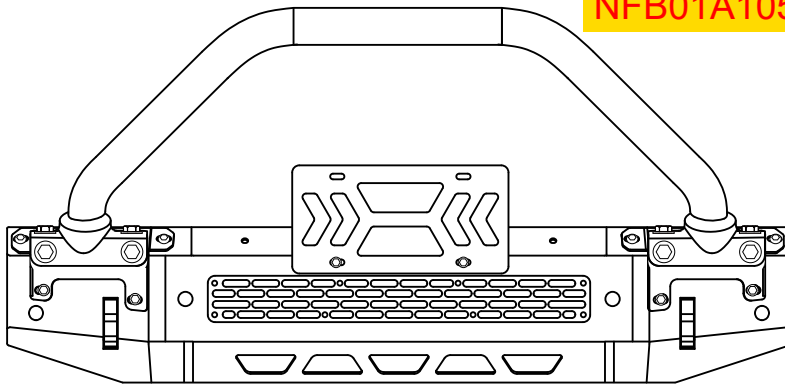

Option 2.

**NFB01A105-1A**

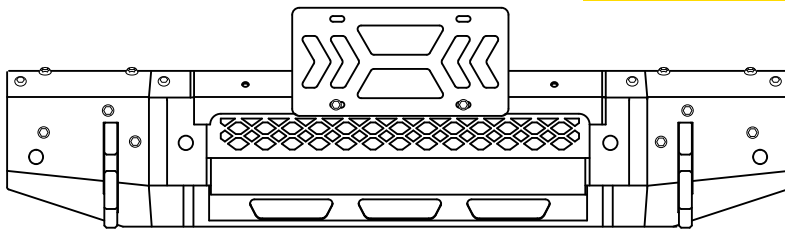

**NFB01A105-1B**

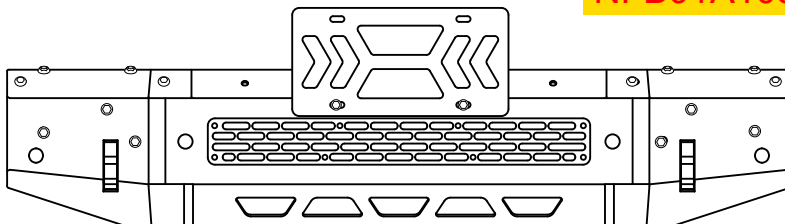

# FRONT BUMPER SIDE WINGS

————— User Manual —————

2021-2023 Ford Bronco(not Bronco Sport)

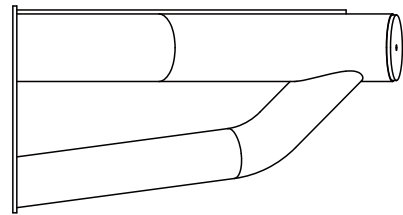
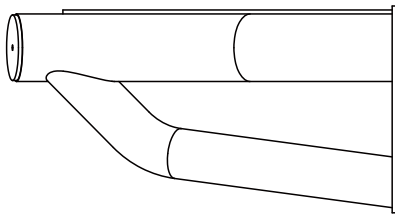

Model:	NFB01A105-2A
Material:	Q235A
Product Dimensions:	11.6 x 8 x 6.1 inch
Package Dimensions:	20.7 x 28.5 x 8.7 inch
Product Weight:	19.8 lbs

---

※ Thank you for purchasing the FRONT BUMPER SIDE WINGS. Please read this manual carefully and keep it properly if you need to refer to it afterward. If you need any support or assistance, please contact us with your product model number and order number, and our support team will help you solve problems.





**⚠ WARNING**

※ This product is designed primarily to enhance the appearance of the vehicle. Do not rely in any way on the components of this product to protect against injury or death in the event of an accident. To reduce the risk of serious injury or property damage, please read all safety messages and understand all instructions and procedure notices before attempting to install or use this product.



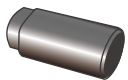

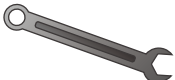
**⚠ CAUTION**

※ Properly torque and recheck fasteners and security of step tread after 250 miles and inspect frequently. Do not use if damaged.

# REQUIRED TOOLS

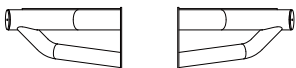
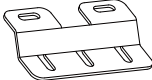
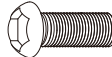
Socket 	Ratchet 	Wrench 	Allen Wrench 	Safety Glasses 
---	--	---	--	---

## Parts Information

NO.	Parts Name	Size	Line Graph	Qty	Color
/	Side Wings	/	① 	1	Black
/	Light brackets	/	② 	1	Black
B19	Half Head Allen Bolts	M8x25	③ 	11	Dacro Black
W16	Spring Washer	Φ8	④ 	11	Dacro Black
W19	Flat Washer	Φ8x24x2	⑤ 	17	Dacro Black
N22	Hex Nuts	M8	⑥ 	11	Dacro Black

**Note:**

spare parts such as B19、 W16、 W19、 N22 are provided with 1PCS each (included in the number of parts details).

# Installation Instructions

**Step 1:** Open the carton and take out the parts. Check whether the number of components is complete.

**Step 2:** Splicing the Light brackets.

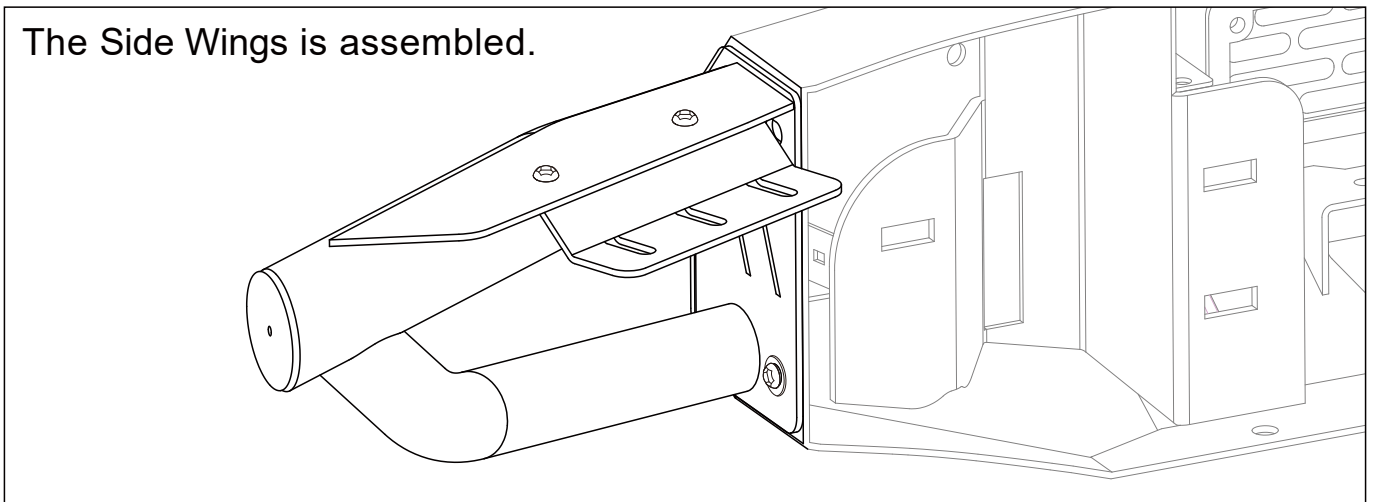
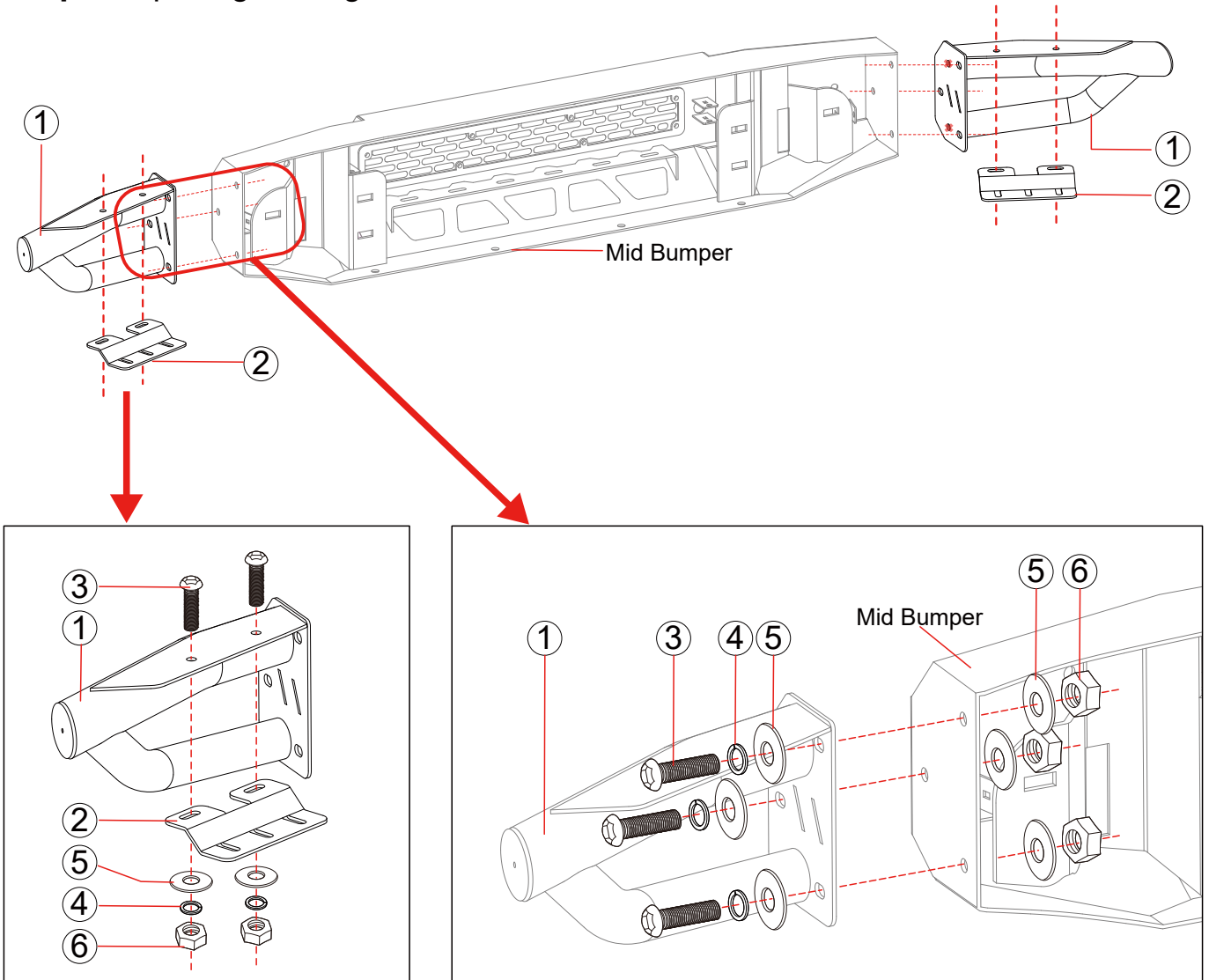

Back

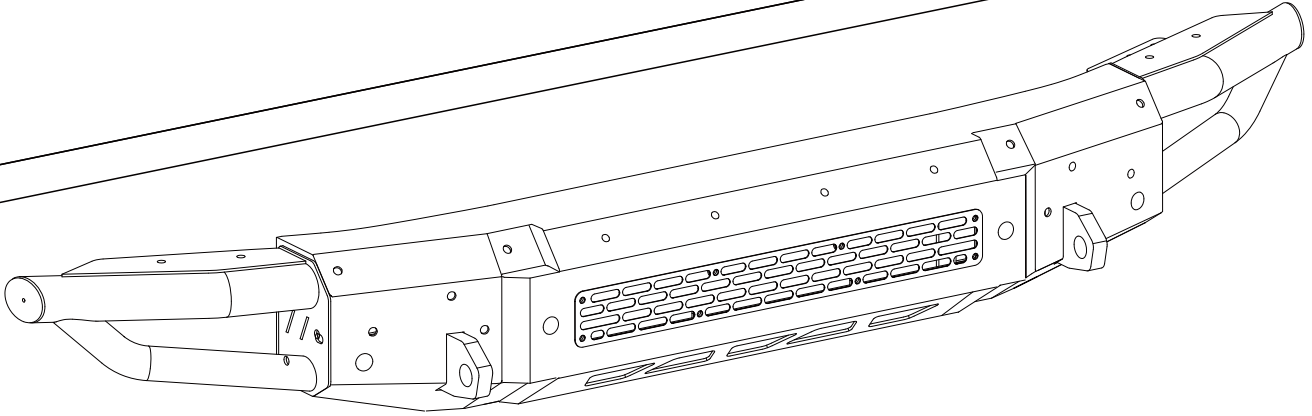
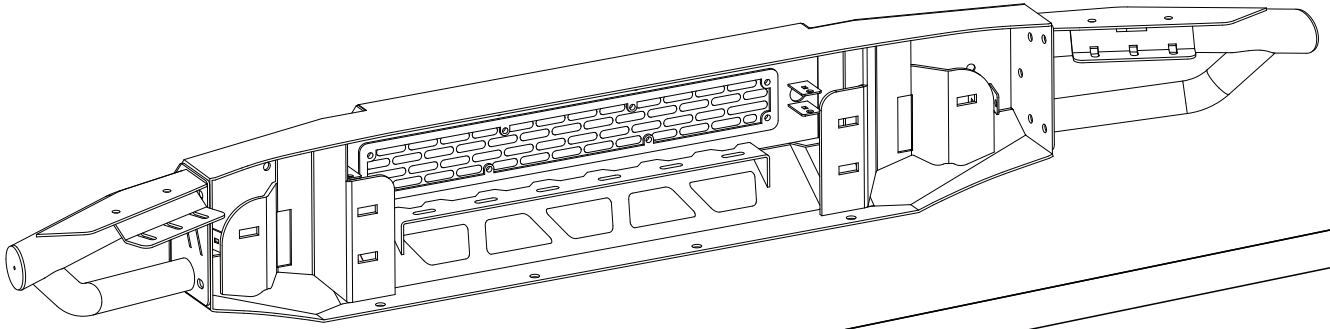

Front

# FRONT BUMPER SIDE WINGS

————— User Manual —————

2021-2023 Ford Bronco(not Bronco Sport)

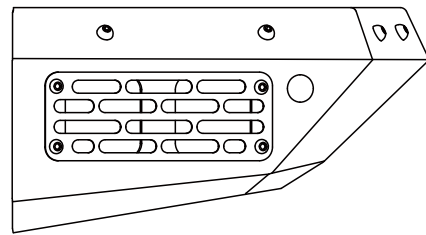
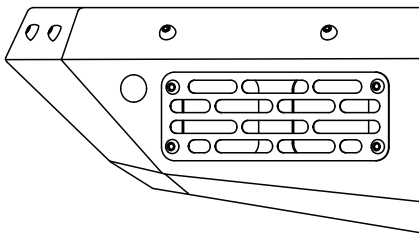

Model:	NFB01A105-2B
Material:	Q235A
Product Dimensions:	12 x 10.2 x 6.5 inch
Package Dimensions:	20.7 x 28.5 x 8.7 inch
Product Weight:	19.8 lbs

---

※ Thank you for purchasing the FRONT BUMPER SIDE WINGS. Please read this manual carefully and keep it properly if you need to refer to it afterward. If you need any support or assistance, please contact us with your product model number and order number, and our support team will help you solve problems.

**⚠ WARNING**



※ This product is designed primarily to enhance the appearance of the vehicle. Do not rely in any way on the components of this product to protect against injury or death in the event of an accident. To reduce the risk of serious injury or property damage, please read all safety messages and understand all instructions and procedure notices before attempting to install or use this product.

**⚠ CAUTION**





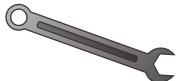

※ Properly torque and recheck fasteners and security of step tread after 250 miles and inspect frequently. Do not use if damaged.

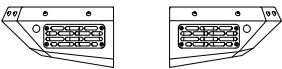

# REQUIRED TOOLS

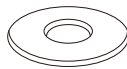
Socket 	Ratchet 	Wrench 	Allen Wrench 	Safety Glasses 
---	--	---	--	---

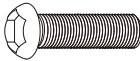
## Parts Information

NO.	Parts Name	Size	Line Graph	Qty	Color
/	Side Wings	/	① 	1	Black
B20	Hex Bolts	M8x25	② 	7	Dacro Black
W16	Spring Washer	Φ8	③ 	7	Dacro Black
W19	Flat Washer	Φ8x24x2	④ 	13	Dacro Black
N22	Hex Nuts	M8	⑤ 	7	Dacro Black
B46	Half Head Allen Bolts	M6x40	⑥ 	3	Dacro Black
N09	Hex Flange Nuts	M6	⑦ 	3	Dacro Black

**Note:**

spare parts such as B20、W19、W16、N22、B46、N09 are provided with 1PCS each (included in the number of parts details).

# Installation Instructions

**Step 1:** Open the carton and take out the parts. Check whether the number of components is complete.

**Step 2:** Splicing the Side Wings.

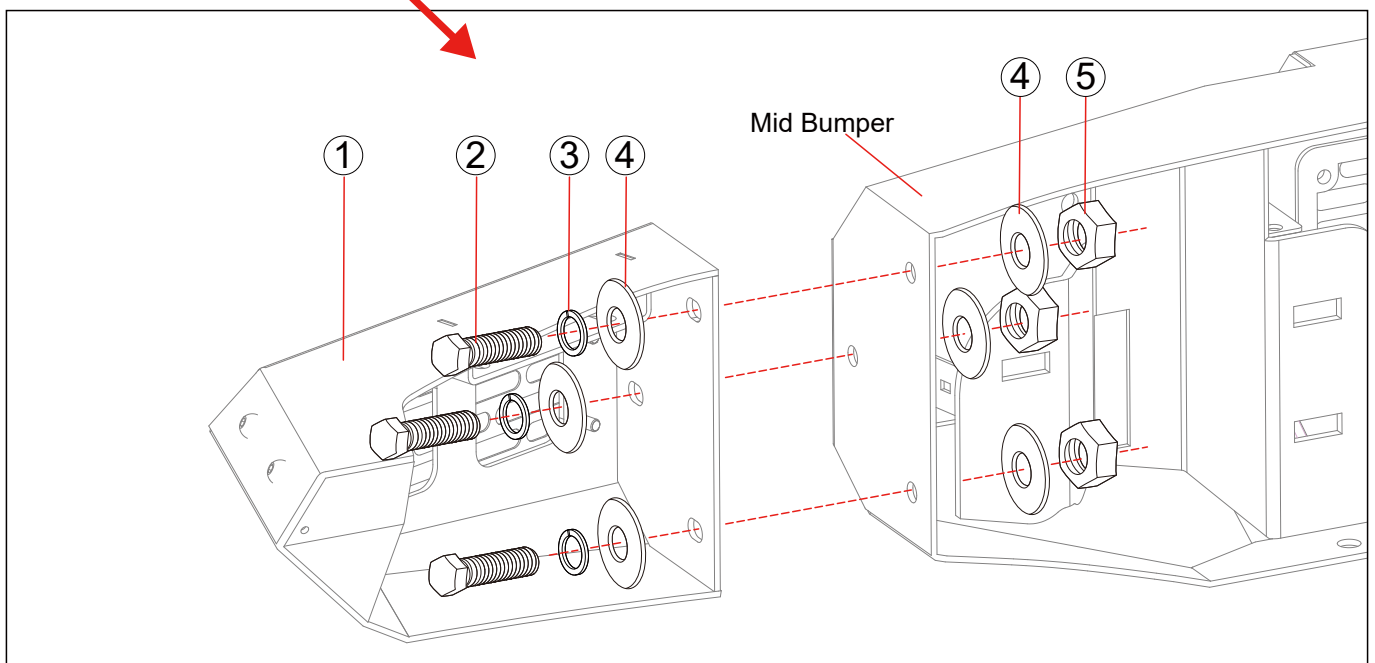
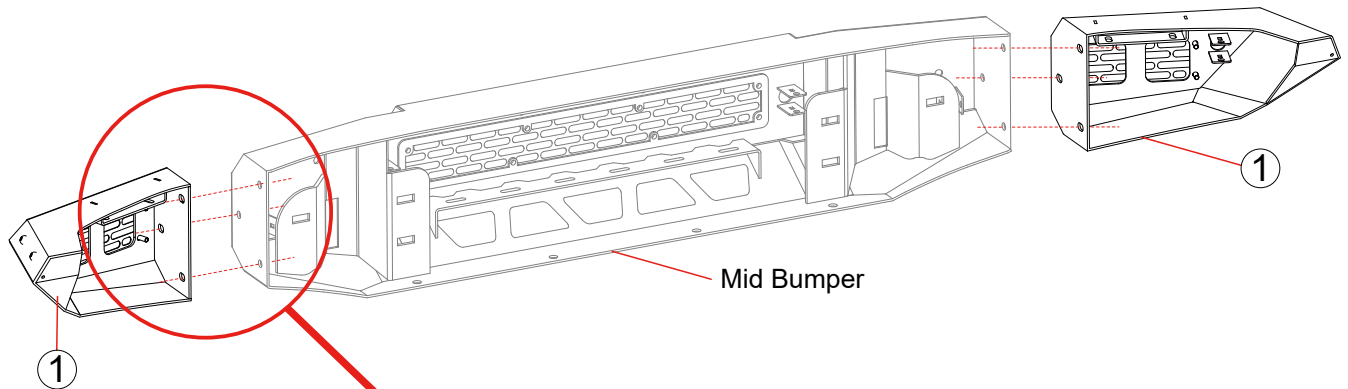

The Side Wings is assembled.

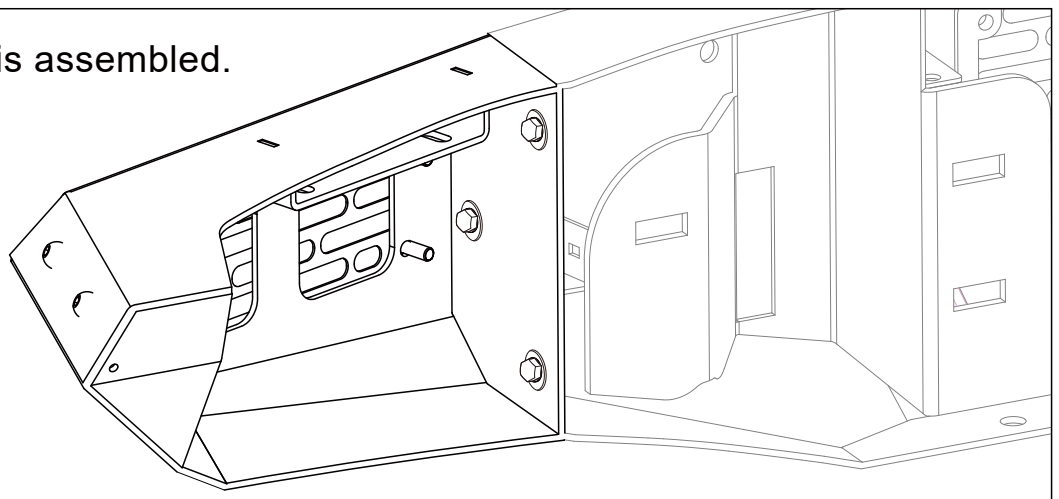

Back

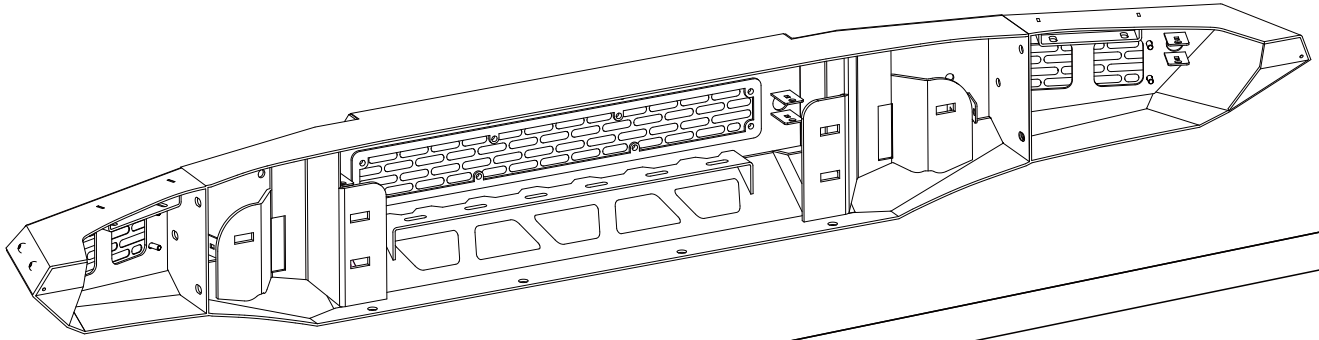

Front

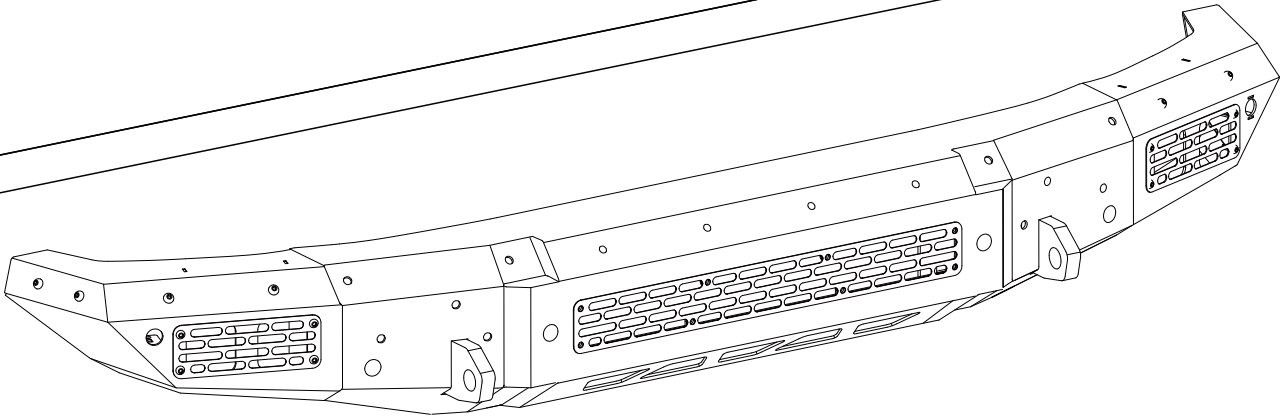

**Step 4: Install the Radar Probe.**

**Note:** If the car does not have a radar probe, this step can be ignored.

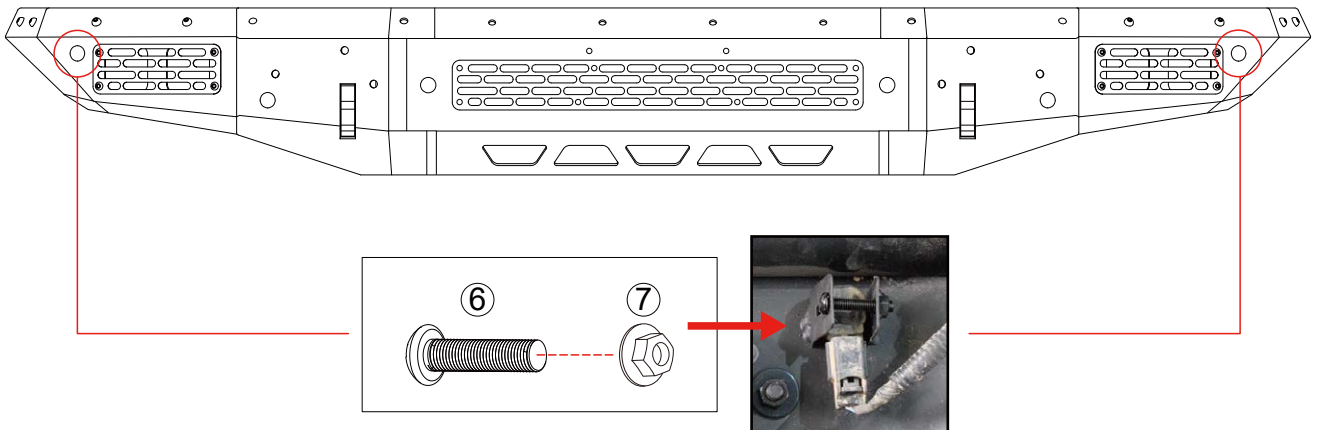

# FRONT BUMPER SKID PLATE

————— User Manual —————

2021-2023 Ford Bronco(not Bronco Sport)

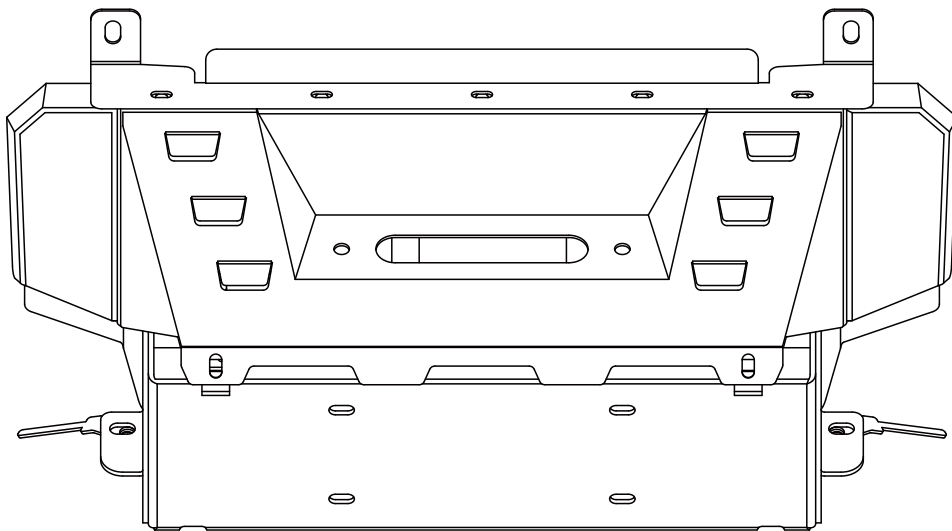

Model:	NFB01A105-4
Material:	Q235A
Product Dimensions:	33.9 x 14.1 x 18.6 inch
Package Dimensions:	34.6 x 4.3 x 11 inch
Product Weight:	48 lbs

---

※ Thank you for purchasing the FRONT BUMPER SKID PLATE. Please read this manual carefully and keep it properly if you need to refer to it afterward. If you need any support or assistance, please contact us with your product model number and order number, and our support team will help you solve problems.





**⚠ WARNING**

※ This product is designed primarily to enhance the appearance of the vehicle. Do not rely in any way on the components of this product to protect against injury or death in the event of an accident. To reduce the risk of serious injury or property damage, please read all safety messages and understand all instructions and procedure notices before attempting to install or use this product.





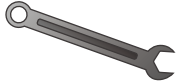



**⚠ CAUTION**

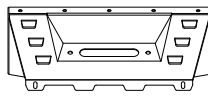

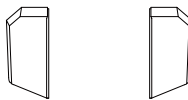
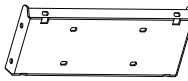
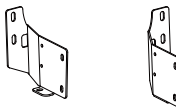



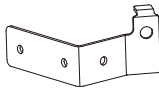
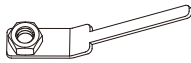



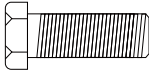
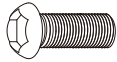

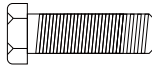

※ Properly torque and recheck fasteners and security of step tread after 250 miles and inspect frequently. Do not use if damaged.



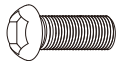

# REQUIRED TOOLS

Socket 	Ratchet 	Wrench 	Allen Wrench 	Safety Glasses 
---	--	---	--	---

## Parts Information

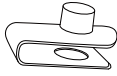
NO.	Parts Name	Size	Line Graph	Qty	Color
/	Skid Plate	/		1	Black
/	Connection Plate	/		1	Black
/	Left&Right Side Wings	/		1	Black
/	Winch Bracket	/		1	Black
/	Left&Right Winch Bracket	/		1	Black
/	Cooler Bracket	/		1	Black
/	Cooler Bracket	/		1	Black
/	Control box Bracket	/		1	Black
/	Booster Pumps Bracket	/		1	Black
/	Screw Plates	/		2	Black
/	Flat Washer	/		2	Black

NO.	Parts Name	Size	Line Graph	Qty	Color
N19	Hex Nuts	M12		5	Dacro Black
B37	Hex Bolts	M12x35		7	Dacro Black
B70	Half Head Allen Bolts	M12x25		3	Dacro Black
W27	Flat Washer	Φ12x30x3		13	Dacro Black
W25	Spring Washer	Φ12		9	Dacro Black
B20	Hex Bolts	M8x25		9	Dacro Black
B71	Hex Bolts	M8x35		3	Dacro Black
N22	Hex Nuts	M8		9	Dacro Black
W19	Flat Washer	Φ8x24x2		22	Dacro Black
W16	Spring Washer	Φ8		14	Dacro Black
B15	Half Head Allen Bolts	M8x20		6	Dacro Black
S04	Screw	ST4.2x16		3	Dacro Black
N29	Hex Lock Nuts	M6		9	Blue Zinc Plating
S13	Screw	M8x25		2	Blue Zinc Plating
/	Hoseclamp	/		3	SUS304
/	Clamps	/		1	SUS304

NO.	Parts Name	Size	Line Graph	Qty	Color
/	Ribbon	5x250		8	Black
/	Clamping Nuts	M10		3	SUS304
B32	Hex Bolts	M10x30		3	Dacro Black
W23	Flat Washer	Φ10x25x2		3	Dacro Black
W22	Spring Washer	Φ10		3	Dacro Black

※ **Note:**

Spare parts such as N19、 B37、 B70、 W27、 W25、 B20、 B71、 N22、 W19、 W16、 B15、 S04、 N29、 S13、 B32、 W23、 W22 are provided with 1PCS each (included in the number of parts details).



There are **THREE** different installations based on the factory bumper and engine size on the Bronco. One for the plastic bumper (top picture) and one for the steel bumper (bottom picture) and one for the necessary V6 steps. Follow the steps for the particular bumper that is on your vehicle. Both types of installs you will be replacing your factory front plastic gravel guard or metal skid plate. If you have the Rough Country front fabricated modular bumper installed, you will follow the steps for the plastic bumper installation. The V6 steps will be located in the back of this booklet.



**Winch Tray and Skid Plate Installation for Plastic or RC Fabricated Bumper:**

1. Park your vehicle on a clean flat surface, engage the parking brake and block the rear tires.
2. **Save all hardware removed from the vehicle unless otherwise noted.**
3. Open the hood and disconnect the negative terminal on the battery.
4. Remove the gravel guard from the vehicle using a 15mm socket in 6 locations. The two rearmost bolts you only have to loosen to slide the gravel guard off. Once removed, tighten the rearmost bolts back down. **Photo 1**  
\*\*\*\*\*V6 Skip to the back of this instruction booklet now for specific steps\*\*\*\*\*
5. On the front of the frame you will find extensions that need to be removed to install the winch. Use a suitable cutting tool (Sawzall shown) and remove these even with the frame rail as shown. You will have 4 sides on each extension to cut through. Do not cut through the electrical or brake lines. **Photo 2**

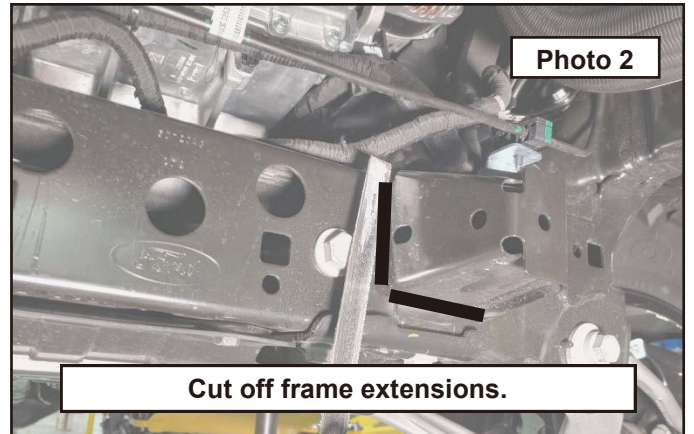
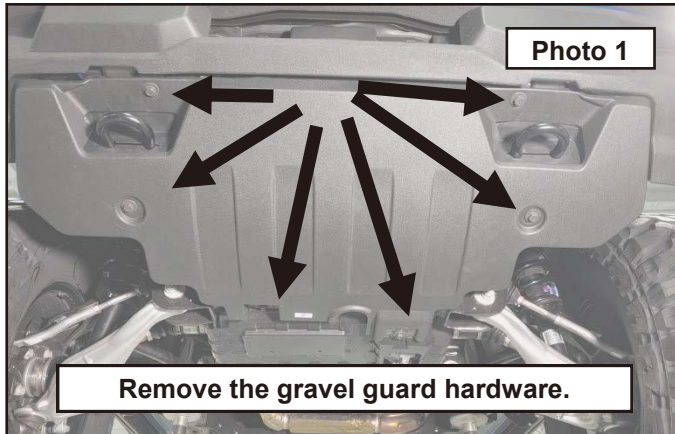

6. Remove the frame extensions. **Photo 3**
7. Sand any burrs and sharp edges smooth. Paint the exposed metal with a quality rest preventative paint. **Photo 4**

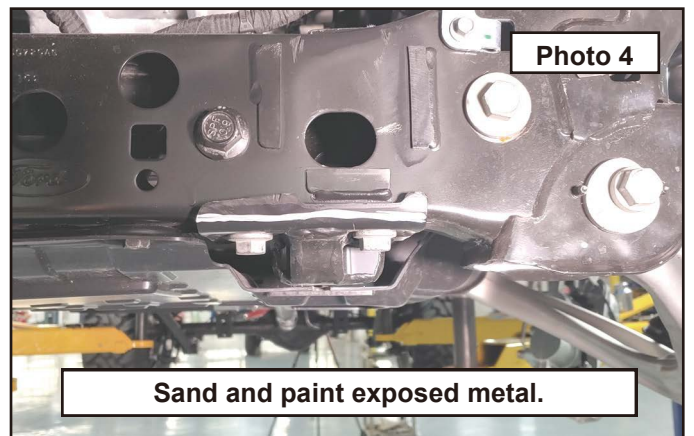
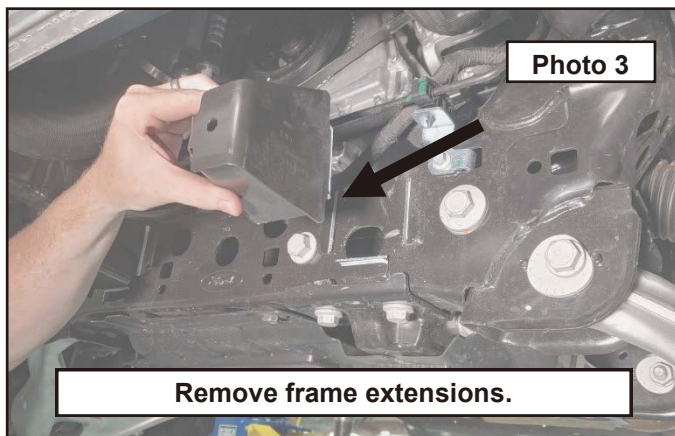

8. Locate the winch tray and the driver and passenger side mounts. **Photo 5**
9. Install the mounts to the tray using the provided 12mm bolts, washers and flange nuts as shown using a 18 and 19mm wrench. **Photo 6**

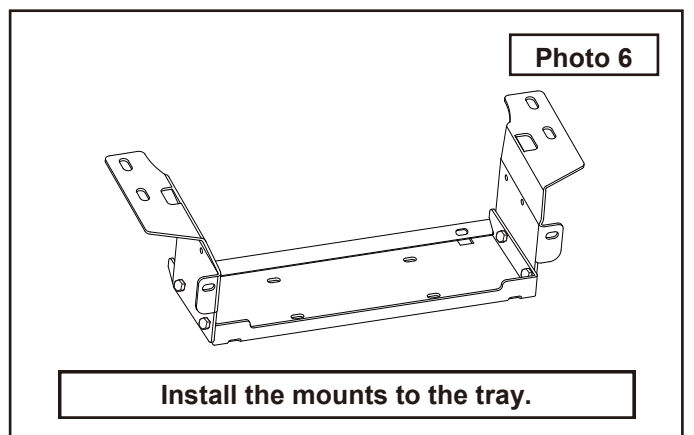
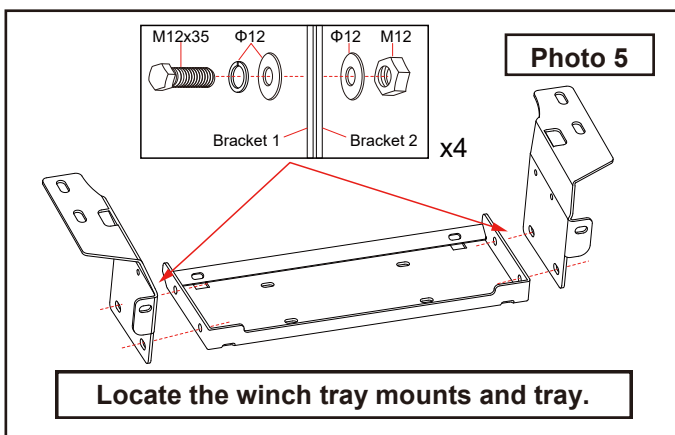

10. Install the winch to the winch tray using the hardware provided with the winch as shown. It is easier to place the winch upside down and then install the tray to the winch. This kit was specifically designed around the RC 9500 and 12000 lb winch with synthetic rope and Hawes fairlead. **Photo 7 / 8**

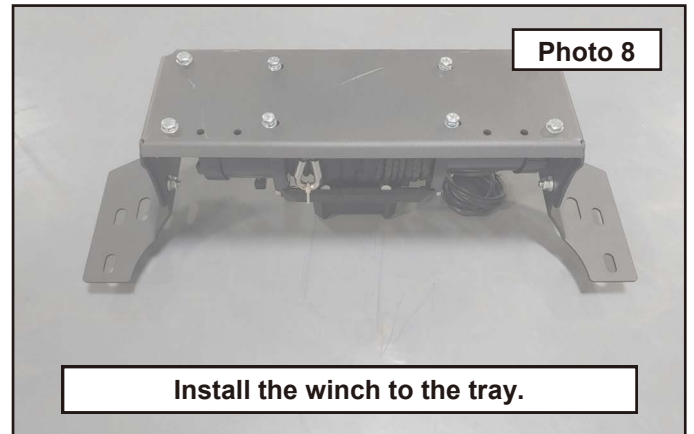
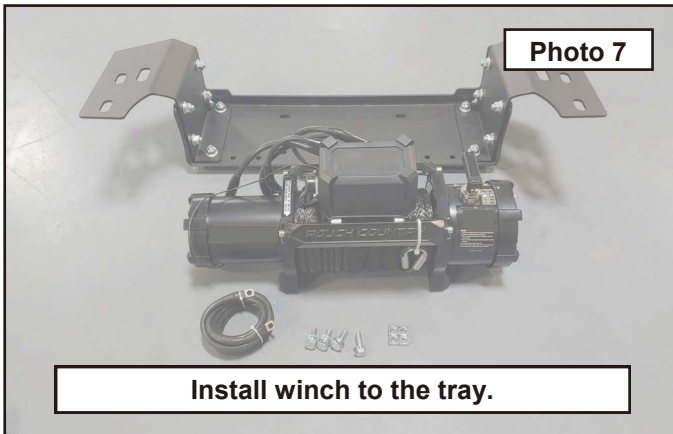

11. If stock tow rings are installed, remove the tow ring filler panel by pulling out and away from the tow rings. **Photo 9**  
 12. Remove the factory tow rings using a 15mm socket. The intercooler is held in place with these as well and you will need to support it as you remove the tow rings. If you have the Rough Country tow hook brackets installed, remove the same way. **Photo 10**

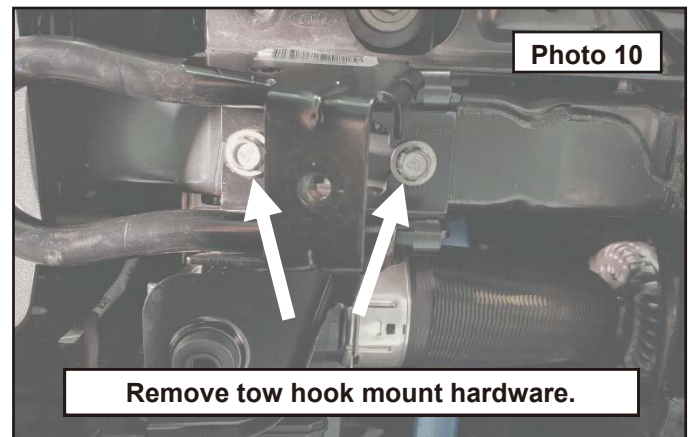
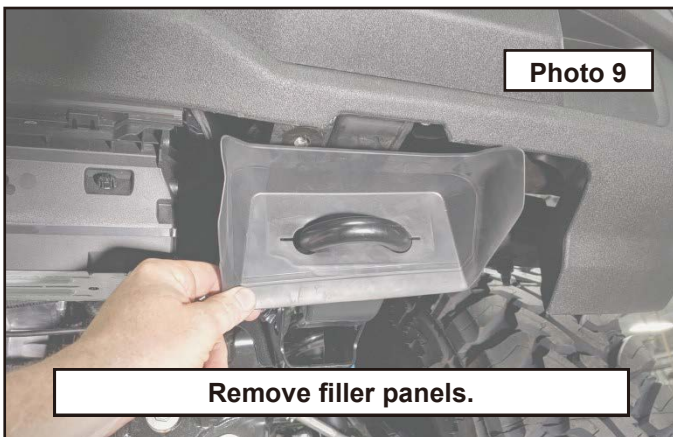

13. Remove the intercooler rubber isolator by twisting and pulling down away from the intercooler. Install the intercooler washer onto the top of the isolator. Reinstall the rubber isolator onto the intercooler. **Photo 11**  
 14. Use of an assistant, floor jack, or other jack is recommended. Raise the assembled winch tray up to the frame rails of the vehicle while holding the intercooler out of the way. **Photo 12**

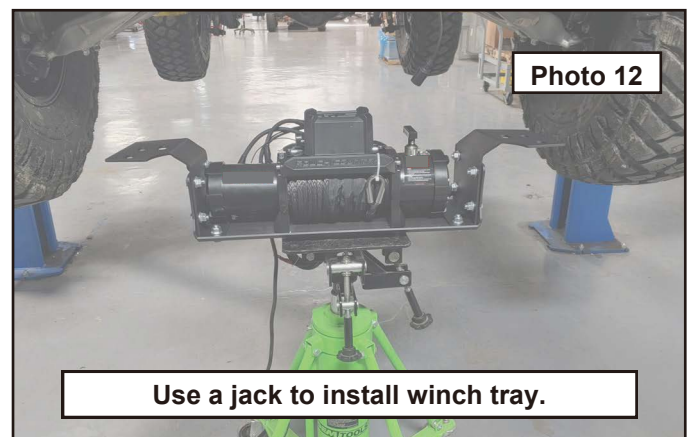
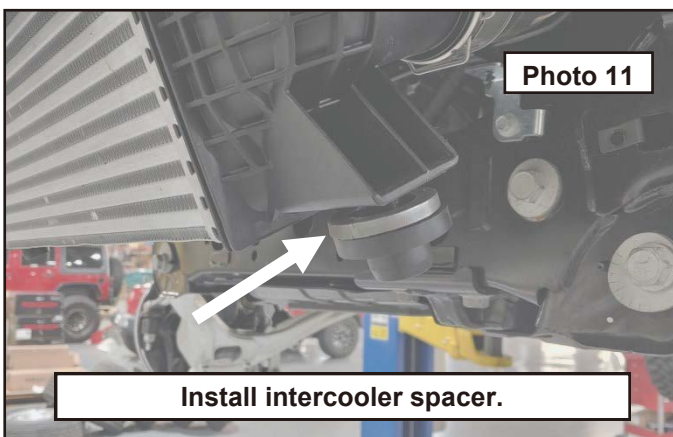

15. Install the provided nut tab through the frame opening until the nut lines up with the round hole in the frame and winch tray. **Photo 13**
16. Install provided 7/16" bolt and washers. Leave loose at this time. **Photo 14**

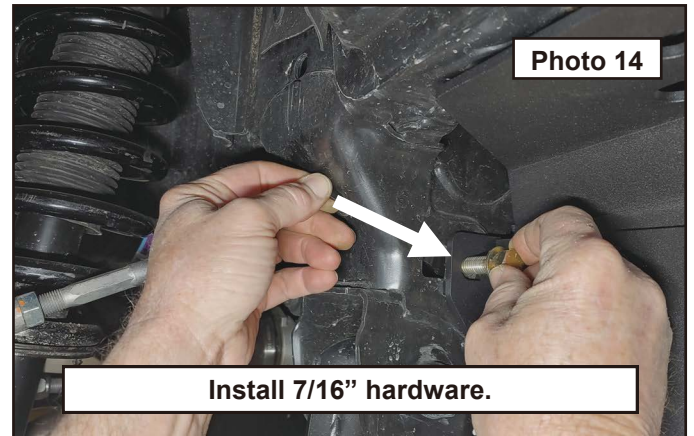
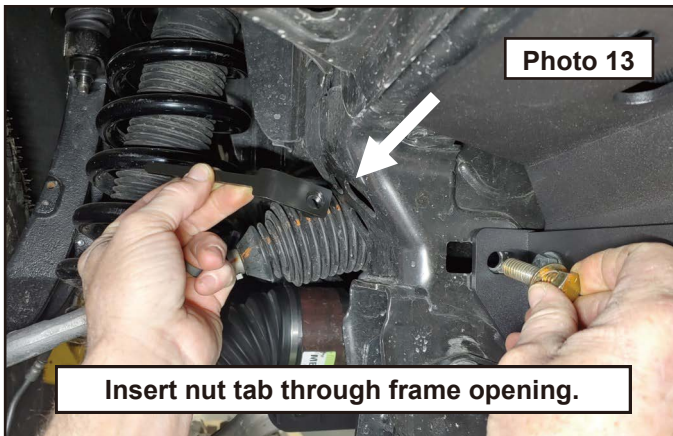

17. If you are installing the factory tow rings back to the vehicle, reuse the factory hardware to sandwich the winch tray to the frame rail while lining up the intercooler mounts. Only snug this hardware up at this time. **Photo 15**
18. If you are installing the Rough Country tow hook brackets, do the same as above with the factory hardware. Once you have both sides in place, torque the back two bolts above the lower control arm cam bolts to 35 ft-lbs, pull the tow hooks as far forward in their slots as possible and torque to 45 ft-lbs. Shown with the Rough Country Bull Bar option brackets from the bull bar kit. **Photo 16**

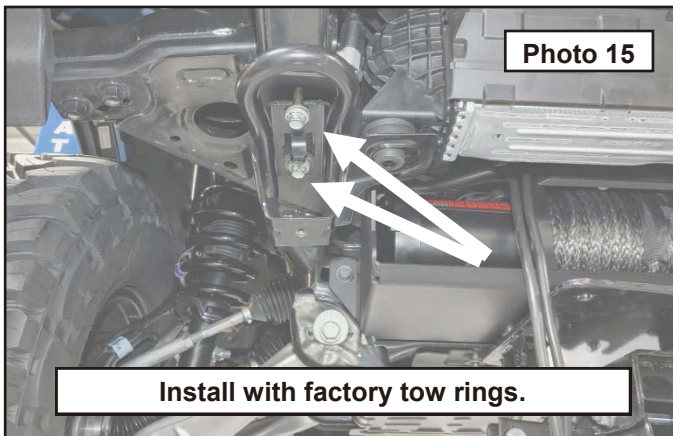

19. Install the provided electrical control box extension to the side of the winch control box. **Photo 17**
20. Route the electrical cables for the winch up through the engine bay to the battery at this time. Cable tie to the battery tray mount and along their route to keep out of harms way from moving components. **Photo 18**

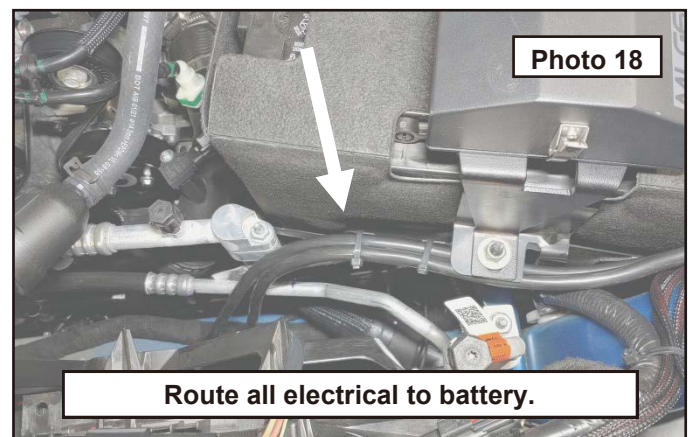
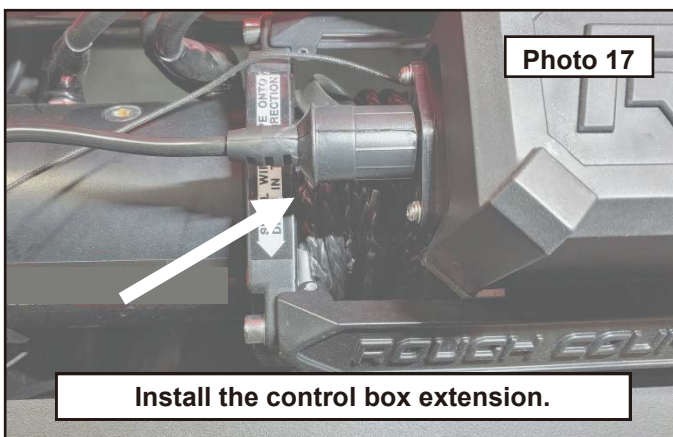

21. Install the bumper filler panel to the winch skid plate using the provided 6mm button head bolts and locking nuts. **Photo 19**
22. Install the Hawes Fairlead to the skid plate using the provided 12mm black button head bolts. **Photo 20**

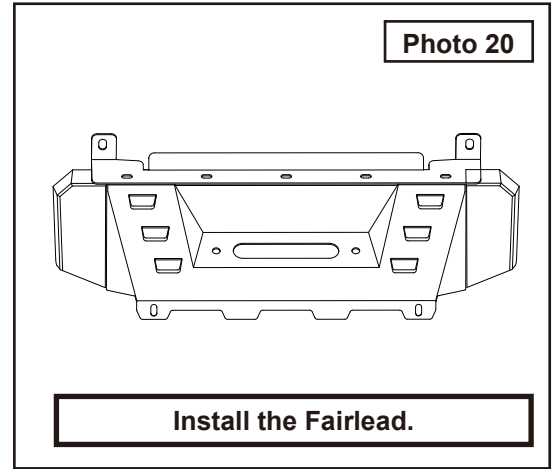
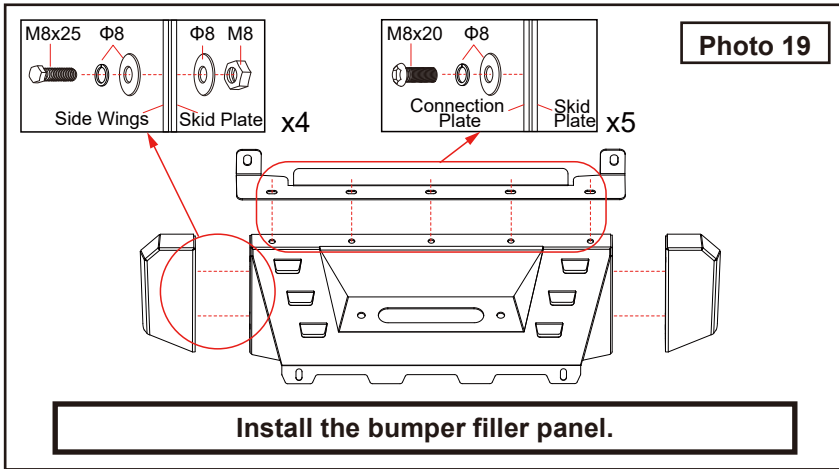

23. Install the winch skid plate to the frame and the factory tow ring brackets using the factory hardware. Torque all to 35 ft-lbs. If you have the Rough Country tow hook brackets, you will need to use the provided 10mm nuts and washers from the tow hook bracket kit and the factory bolts. Slide the nut and washer through the opening in the tow hook bracket. **Photo 21**
24. Under the hood, reconnect the battery negative terminal to the battery. Connect the winch positive and negative cables directly to the connections of the battery. **Photo 22**

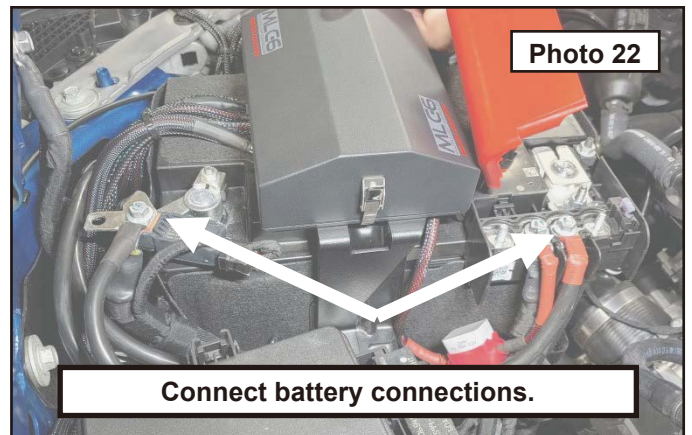
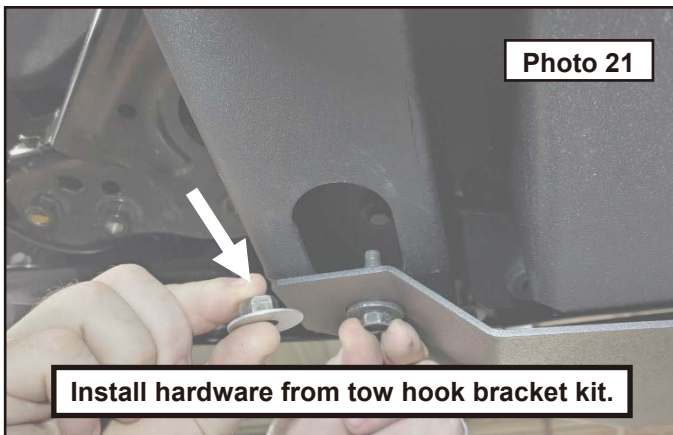

25. Find a suitable place to install the winch control extension to the vehicle. We recommend notching the core support filler panel and screwing in place using the provided screws as shown. **Photo 23**
26. Use a drill and small bit to make a pilot hole. These screws will "self tap" into the plastic. **Photo 24**

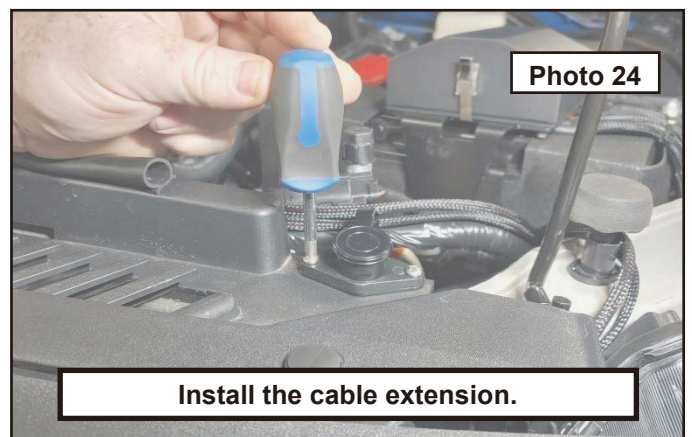
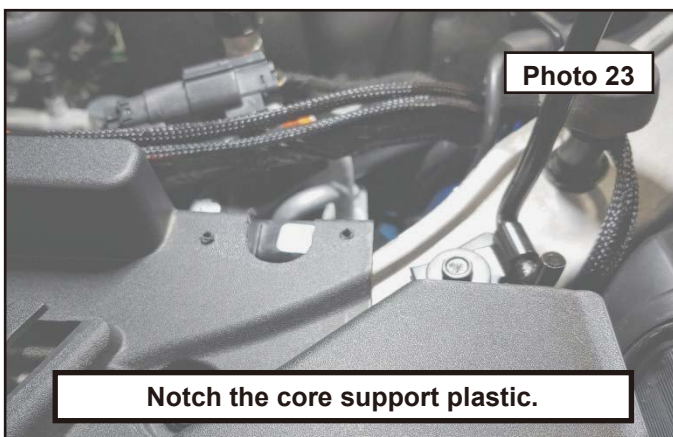

**Winch Tray and Skid Plate Installation for Factory Modular Steel Bumper:**

1. Park your vehicle on a clean flat surface, engage the parking brake and block the rear tires.
2. **Save all hardware removed from the vehicle unless otherwise noted.**
3. Open the hood and disconnect the negative terminal on the battery.
4. Remove the factory skid plate by loosening the rearmost bolts and completely removing the forward most bolts using a 15mm socket. **Photo 1**
5. Slide the skid plate off the rearmost bolts and set aside. Tighten the rearmost bolts back down. **Photo 2**

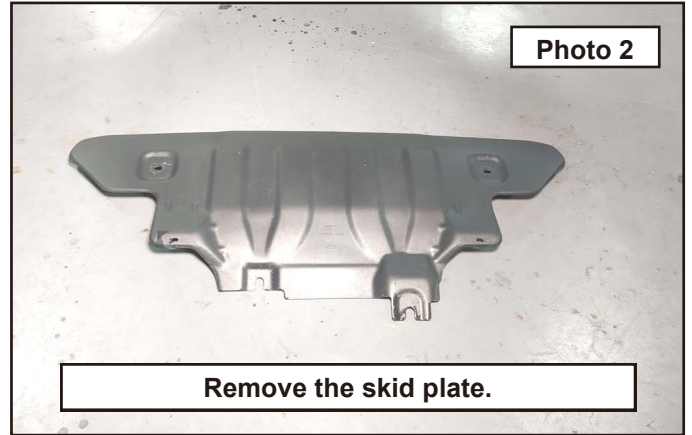
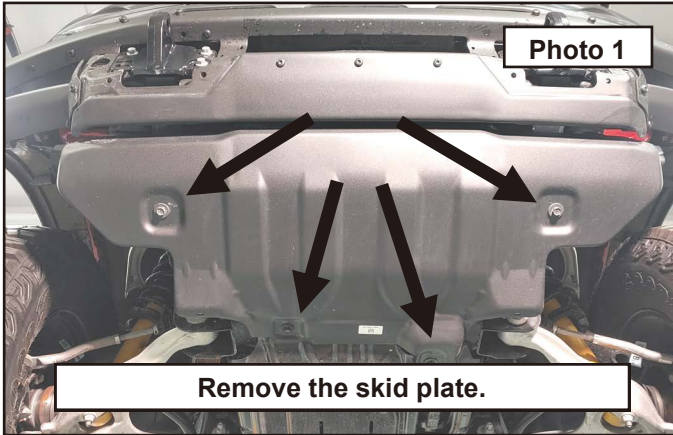

6. Remove the plastic rivets holding the plastic cover in place. Use a pair of pliers or other suitable tool to pull out the middle of the plastic rivet. Remove the rivet body. **Photo 3**
7. Remove the plastic cover and set aside. **Photo 4**

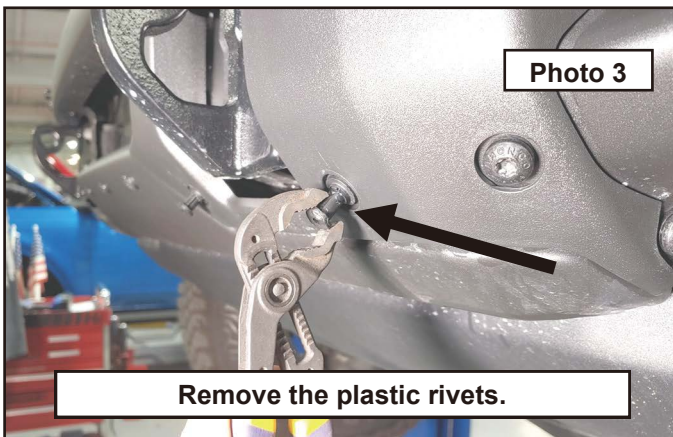

8. If you have proximity sensors in your bumper, disconnect their harness. Behind the plastic cover you will find the main bumper mounting hardware. Have an assistant help hold the bumper and remove the 6 mounting bolts using a 15mm socket. **Photo 5**  
\*\*\*\*\*V6 Skip to the back of this instruction booklet now for specific steps\*\*\*\*\*
9. On the front of the frame you will find extensions that need to be removed to install the winch. Use a suitable cutting tool (Sawzall shown) and remove these even with the frame rail as shown. You will have 4 sides on each extension to cut through. Do not cut through the electrical or brake lines. **Photo 6**

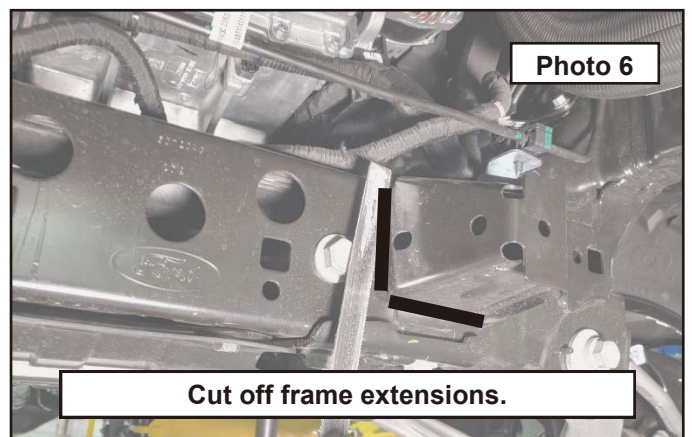
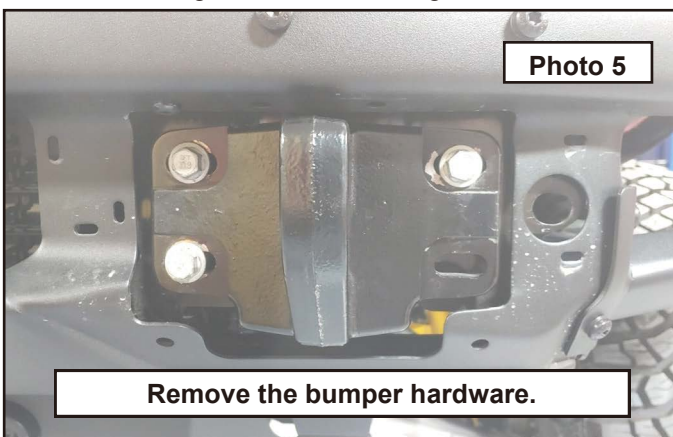

10. Sand any burrs and sharp edges smooth. Paint the exposed metal with a quality rust preventative paint. **Photo 7**  
 11. Remove the factory intercooler mounts using a 15mm socket. Let the intercooler hang out of the way. **Photo 8**

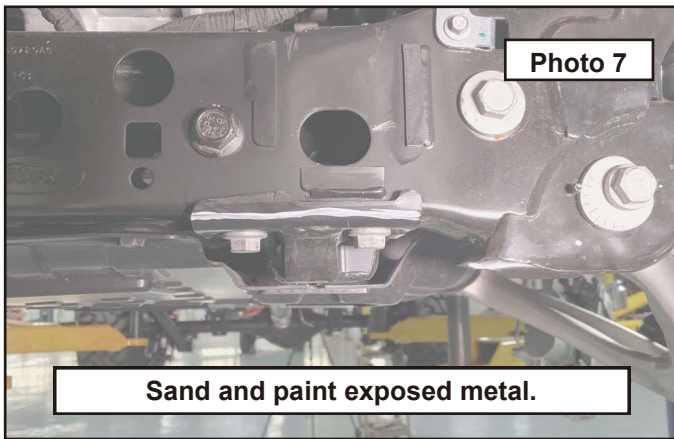

12. Locate the winch tray and the driver and passenger side mounts. **Photo 9**  
 13. Install the mounts to the tray using the provided 12mm bolts, washers and flange nuts as shown using a 18 and 19mm wrench. **Photo 10**

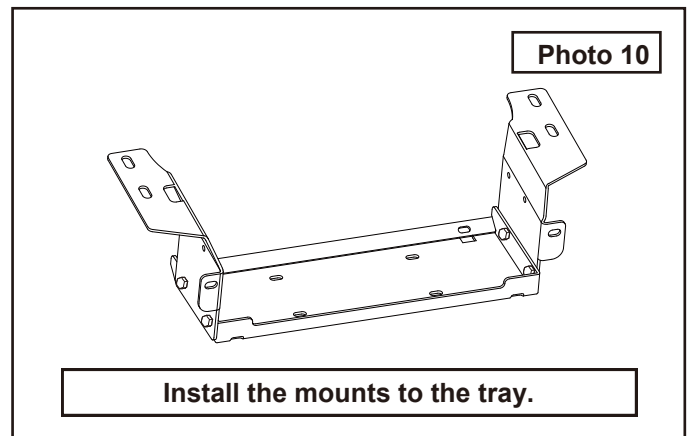
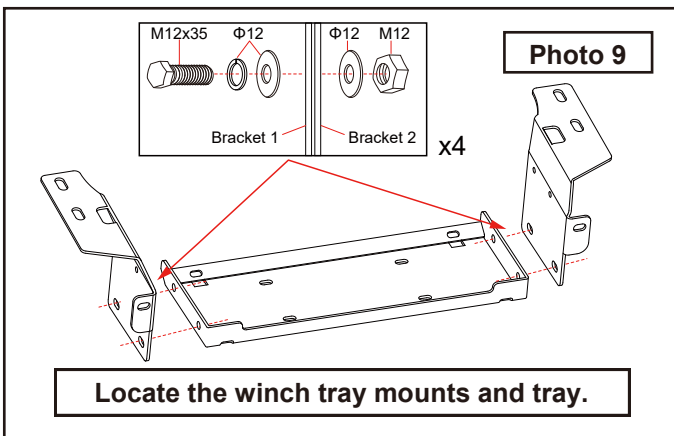

14. Install the winch to the winch tray using the hardware provided with the winch as shown. It is easier to place the winch upside down and then install the tray to the winch. This kit was specifically designed around the RC 9500 and 12000 lb winch with synthetic rope and Hawes fairlead. **Photo 11 / 12**

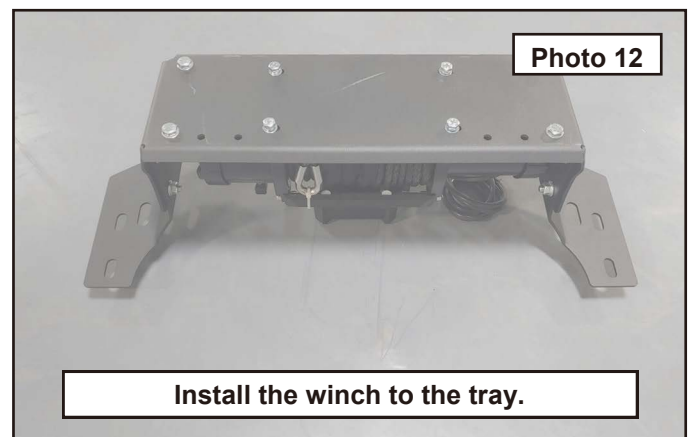
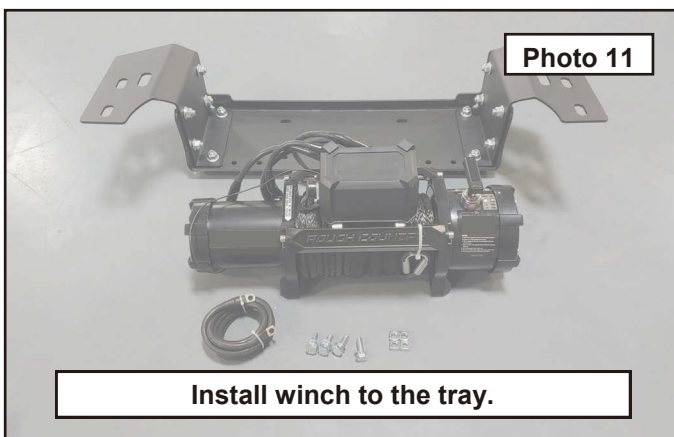

15. Remove the intercooler rubber isolator by twisting and pulling down away from the intercooler. Install the intercooler washer onto the top of the isolator. Reinstall the rubber isolator onto the intercooler. **Photo 13**
16. Use of an assistant, floor jack, or other jack is recommended. Raise the assembled winch tray up to the frame rails of the vehicle while holding the intercooler out of the way. **Photo 14**

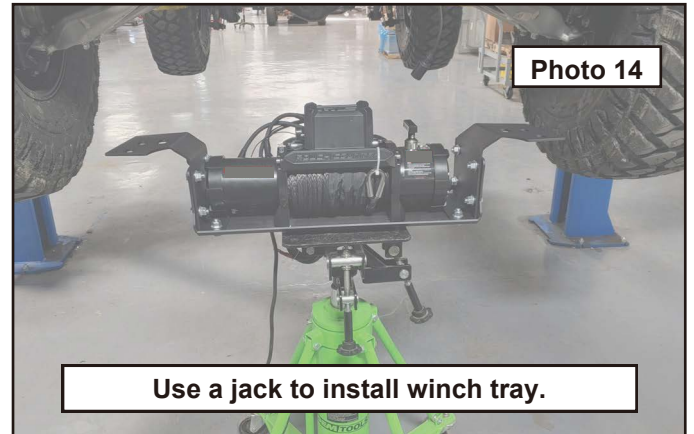
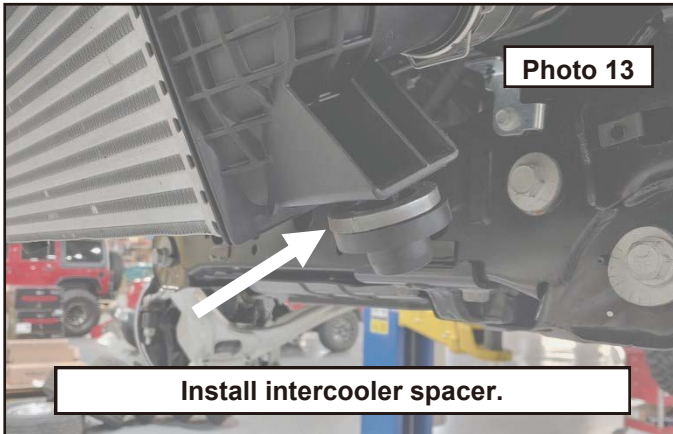

17. Install the provided nut tab through the frame opening until the nut lines up with the round hole in the frame and winch tray. **Photo 15**
18. Install provided 7/16" bolt and washers. Leave loose at this time. **Photo 16**

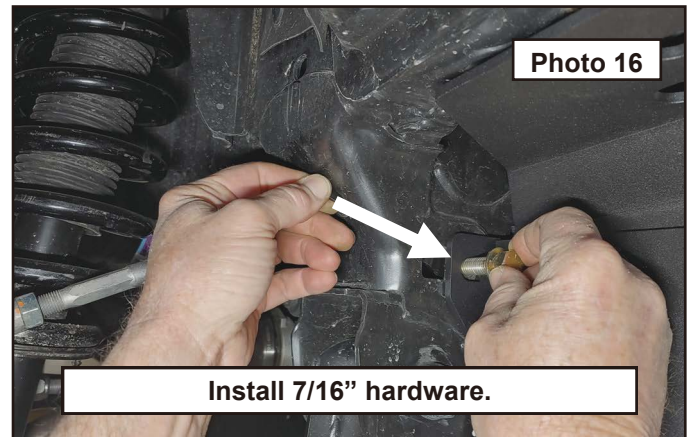
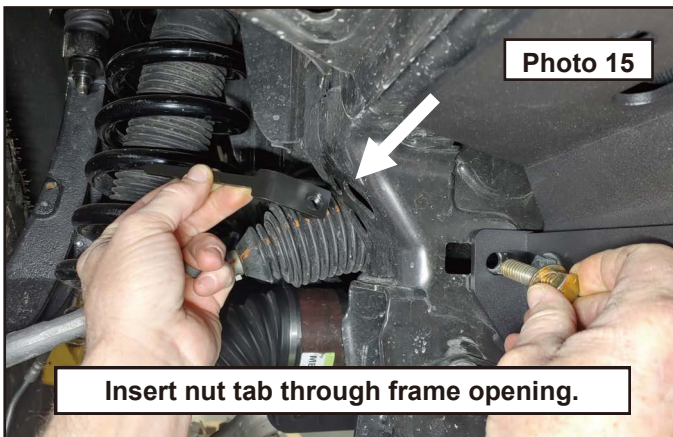

19. Install the intercooler mounts by reusing the factory hardware to sandwich the winch tray to the frame rail while lining up the intercooler mounts. Snug this hardware up. Torque the 7/16" hardware to 35 ft-lbs and then the intercooler hardware to 45 ft-lbs. **Photo 17**
20. Install the provided electrical control box extension to the side of the winch control box. **Photo 18**

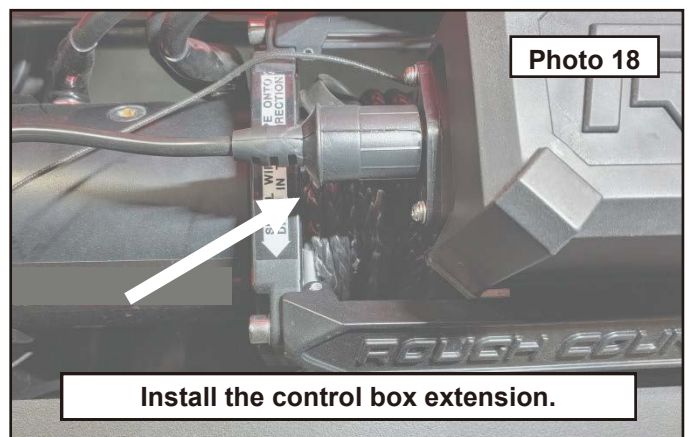
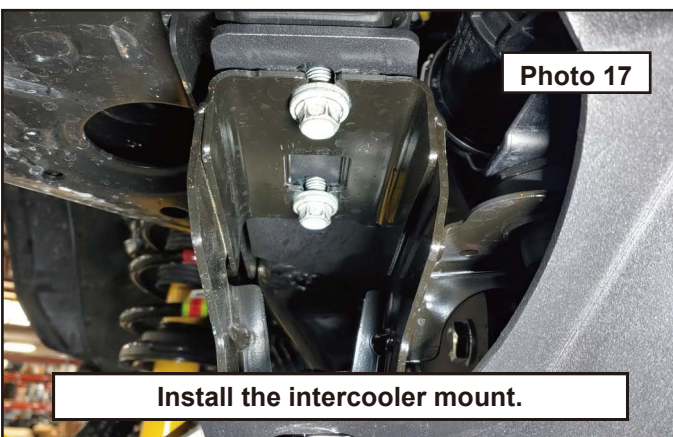



21. Route the electrical cables for the winch up through the engine bay to the battery at this time. Cable tie to the battery tray mount and along their route to keep out of harms way from moving components.
22. Use an assistant to help install the bumper to the frame rails using a 15mm socket. Adjust until the bumper is level and centered on the frame. Torque the hardware to 45 ft-lbs. **Photo 19**
23. Reinstall the plastic bumper covers using the previously removed plastic rivets by inserting the body into the hole and then the head into the body. Push the head in until it seats. **Photo 20**

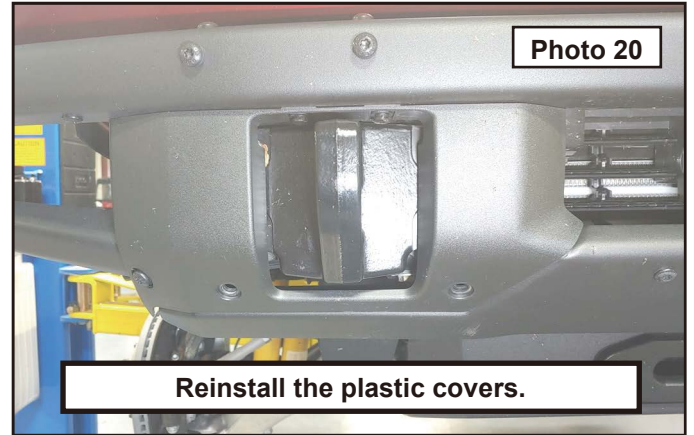
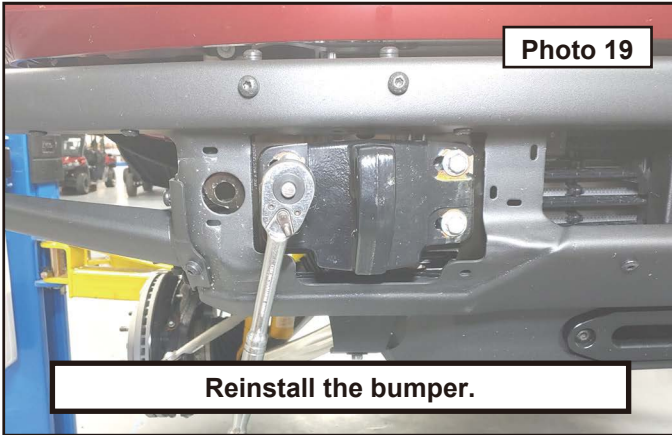

24. Install the winch hook. **Photo 21**
25. Under the hood, reconnect the battery negative terminal to the battery. Connect the winch positive and negative cables directly to the connections of the battery. **Photo 22**

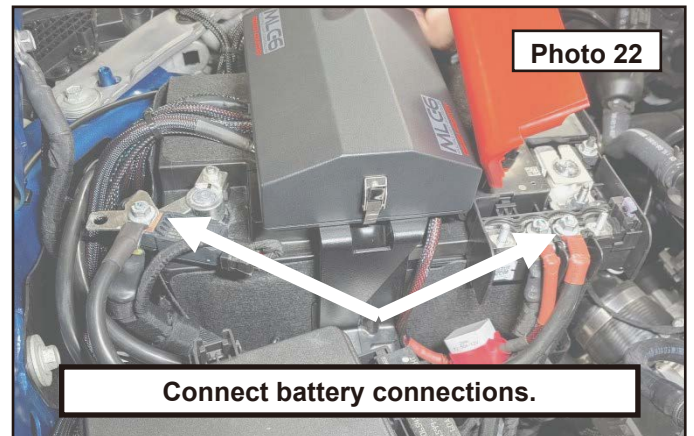

26. Find a suitable place to install the winch control extension to the vehicle. We recommend notching the core support filler panel and screwing in place using the provided screws as shown. **Photo 23**
27. Use a drill and small drill bit to drill a pilot hole. These screws will "self tap" into the plastic. **Photo 24**

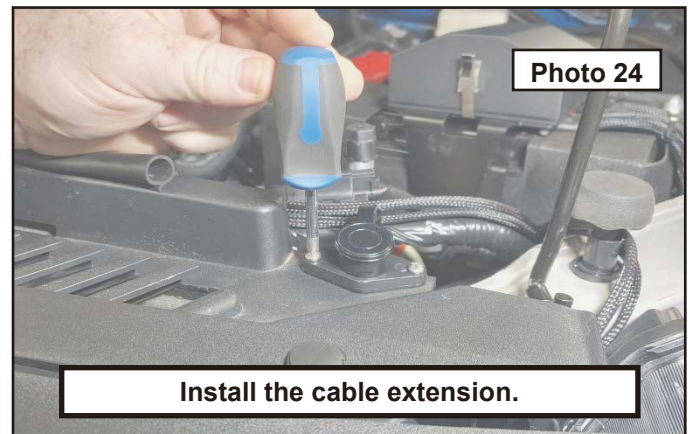
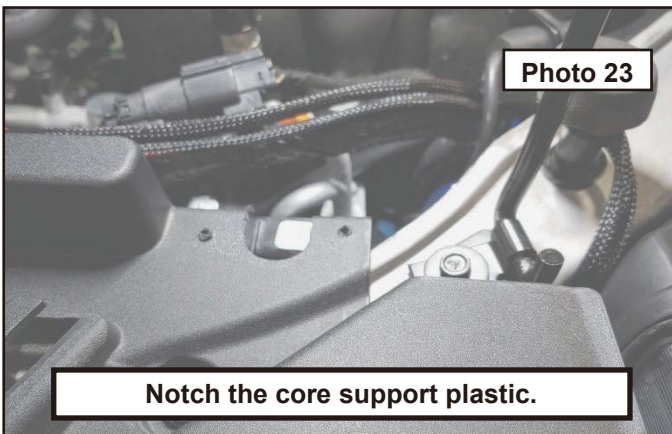

### V6 Model Instructions:

1. Under the hood you will disconnect the driver side charge tube next to the battery by releasing the spring clip. **Photo 1**
2. Pull spring clip back towards the battery until you get the ears to lock into their notches. **Photo 2**

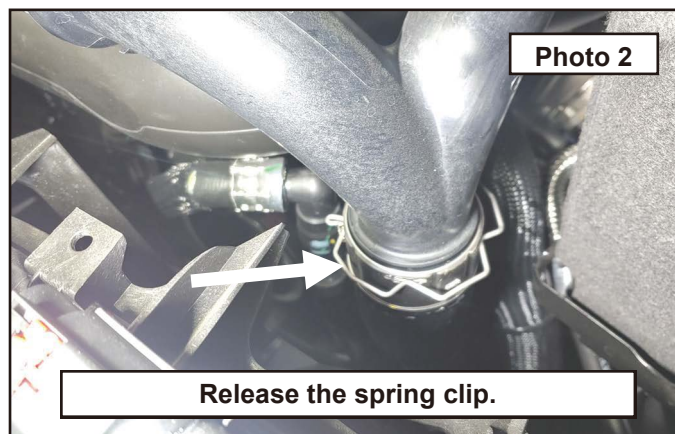
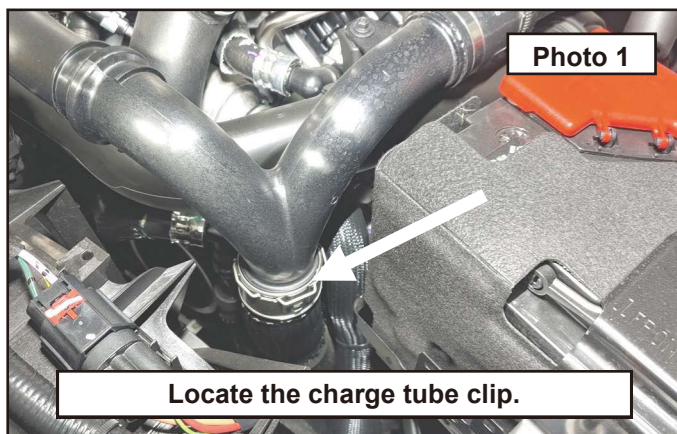

3. Gently push down on the charge tube until it is fully disconnected from the upper plenum. **Photo 3**
4. Move to under the vehicle and locate the transmission cooler and hoses on the front crossmember. You will be removing the coolant pump, coolant hoses and oil cooler. **Photo 4**

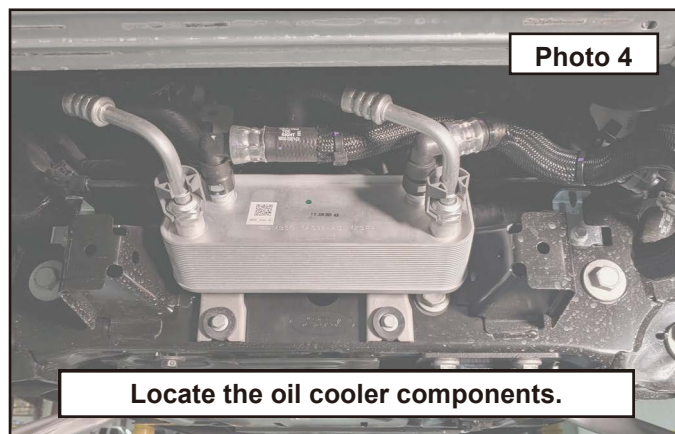
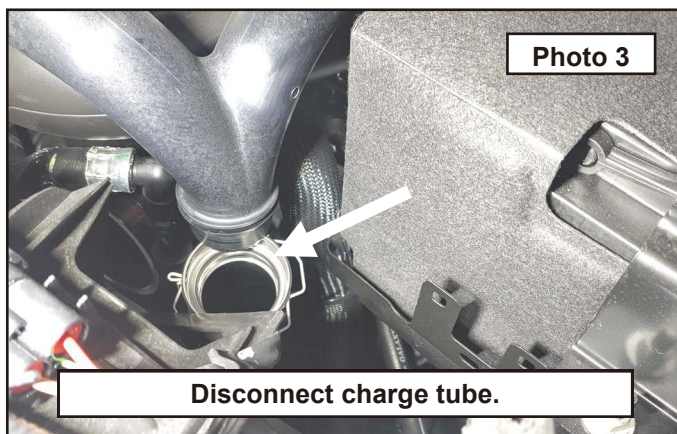

5. Disconnect the coolant boost pump electrical connection. **Photo 5**
6. Remove the coolant boost pump from the frame above the lower control arm mount using a 10mm wrench. Once the bracket is removed from the frame, remove the clip nut from its hole using a pry tool. **Photo 6**

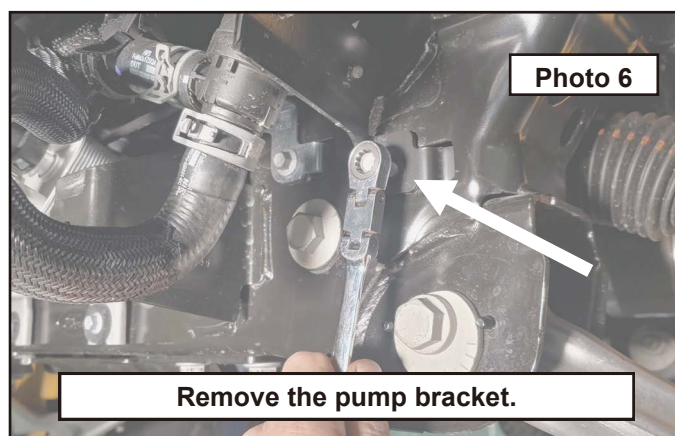
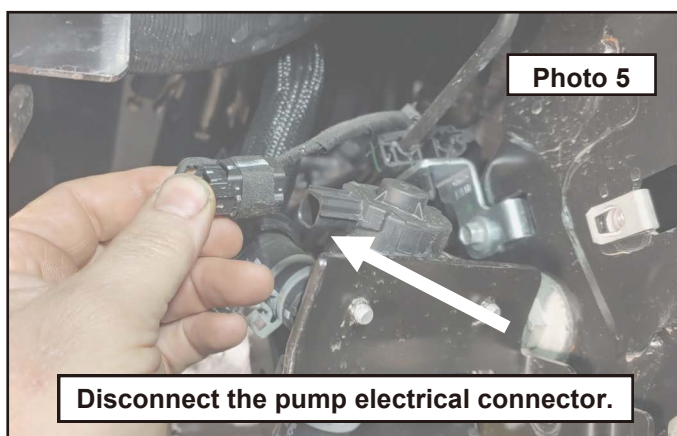

7. With the boost pump out of the way, disconnect the charge pip lower connection in the same fashion as the upper mount. Push towards the engine and then rotate the pipe to remove it from the vehicle. Once removed, unlock the spring clips so that they pop back into place in their mounts. This will allow a positive connection when reinstalled. **Photo 7 / 8**

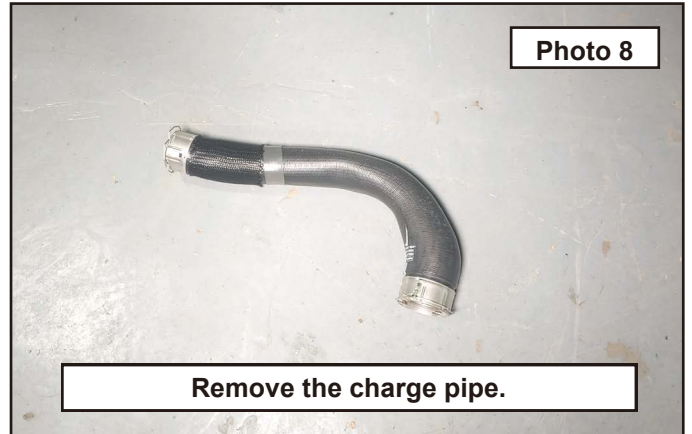
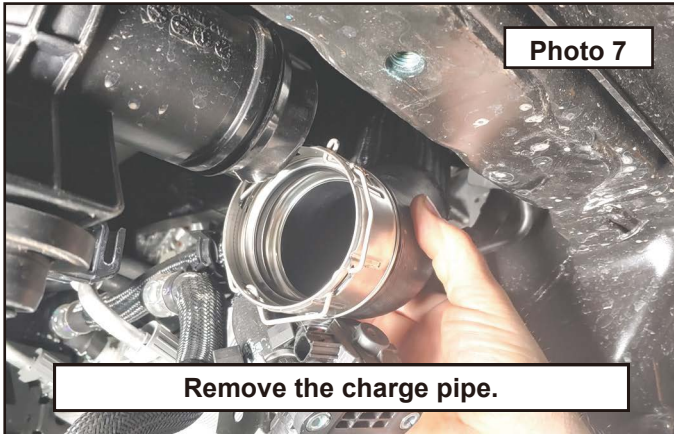

8. Locate both of the feed and return coolant lines and use a pair of locking pliers to pinch off the coolant flow. Do not damage the lines. Clamp the passenger line up above the factory tie clamp so that the pliers are out of the way for future installation instructions. **Photo 9**
9. Place a container under the cooler to catch lost coolant. Use a pair of pliers to depress the locking clip under the quick connect of the coolant lines. **Photo 10**

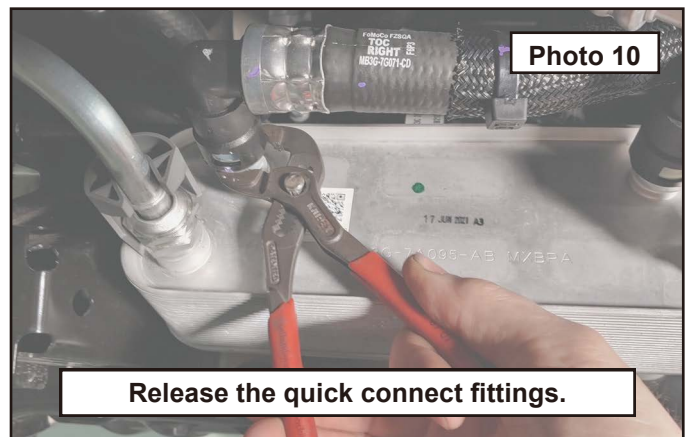
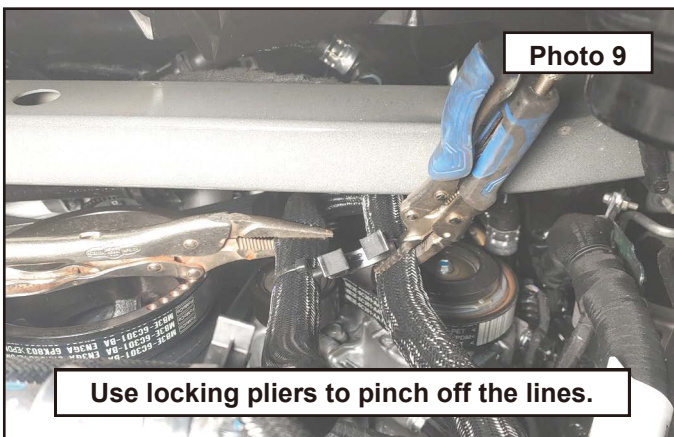

10. Pull the coolant line off the fittings. **Photo 11**
11. Use a pair of pliers to compress the hose clamp on the boost pump. Remove the boost pump from the hose. **Photo 12**

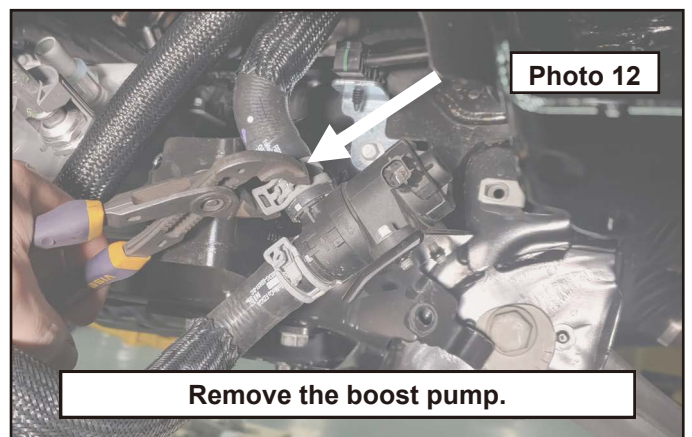
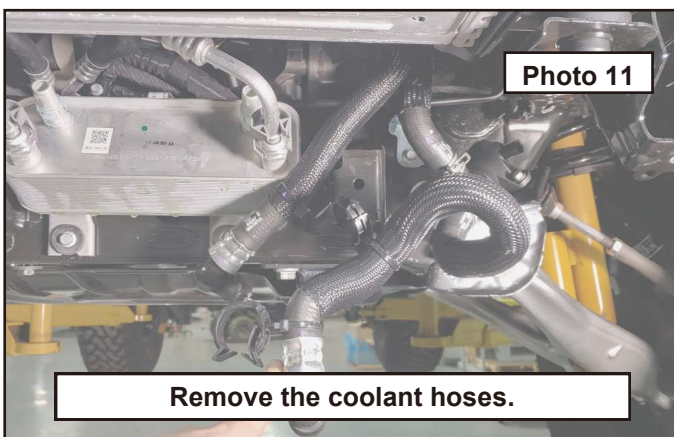

12. Remove the remaining coolant line from the boost pump. **Photo 13**

13. Remove the boost pump from the factory bracket using a 8mm socket. **Photo 14**

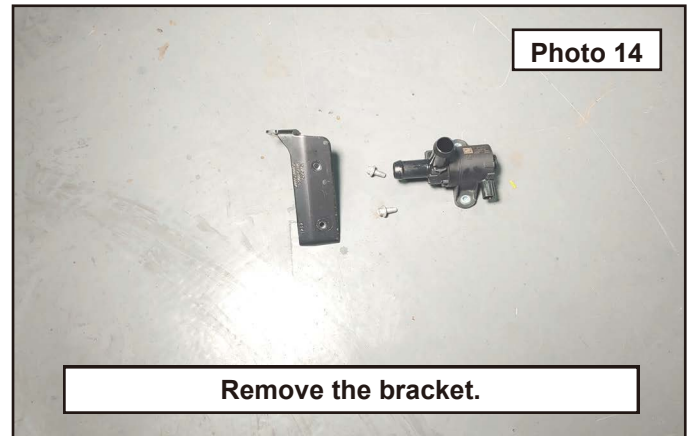
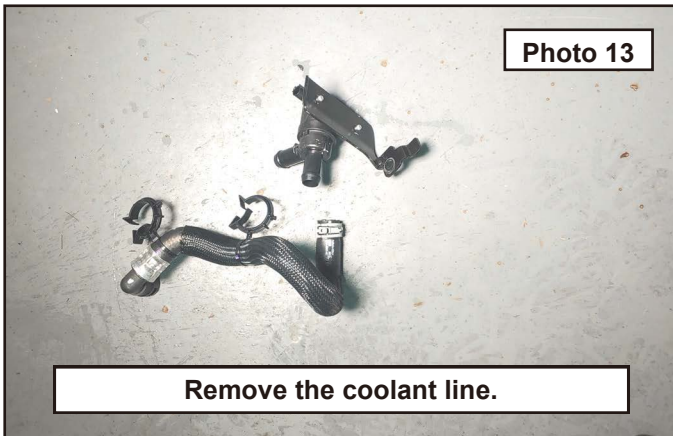

14. Install the boost pump to the Rough Country bracket as shown using the provided 6mm button head bolts and nuts. **Photo 15**

15. On top of the oil cooler, remove the wire harness mount using a 8mm socket. **Photo 16**

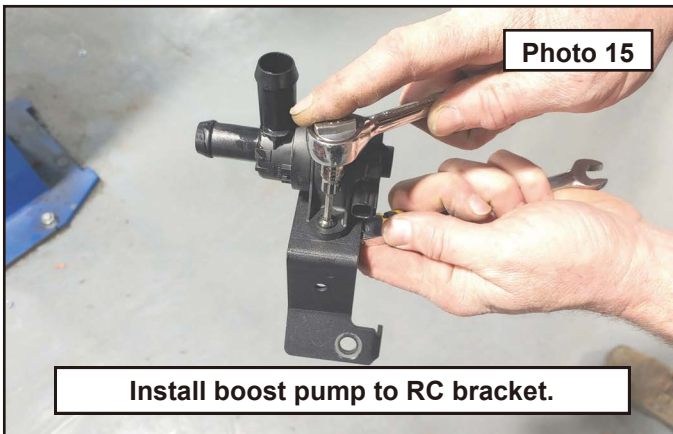

16. Remove the two oil cooler mounts on the top of the frame using a 10mm wrench. **Photo 17**

17. Remove the two oil cooler mounts on the front of the frame using a 10mm wrench. **Photo 18**

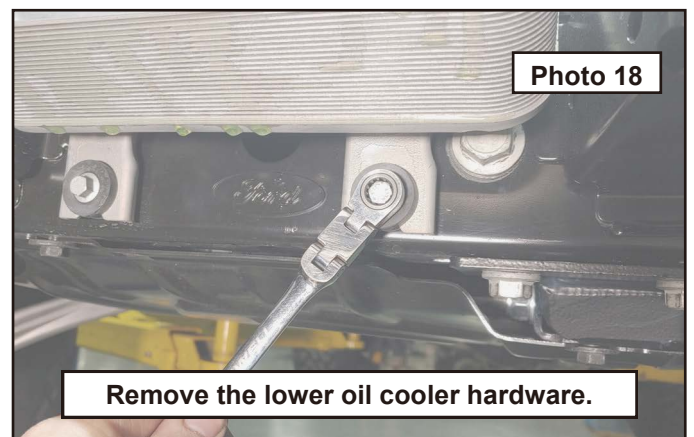
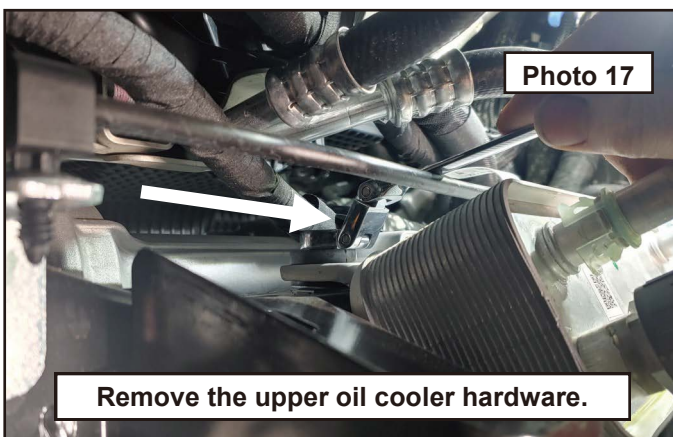

18. Let the oil cooler hang out of the way. **Photo 19**

19. On the front of the frame you will find extensions that need to be removed to install the winch. Use a suitable cutting tool (Sawzall shown) and remove these even with the frame rail as shown. You will have 4 sides on each extension to cut through. Do not cut through the electrical or brake lines. **Photo 20**

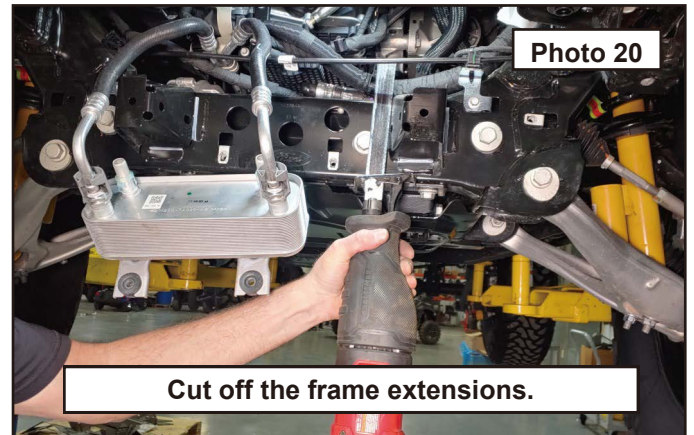
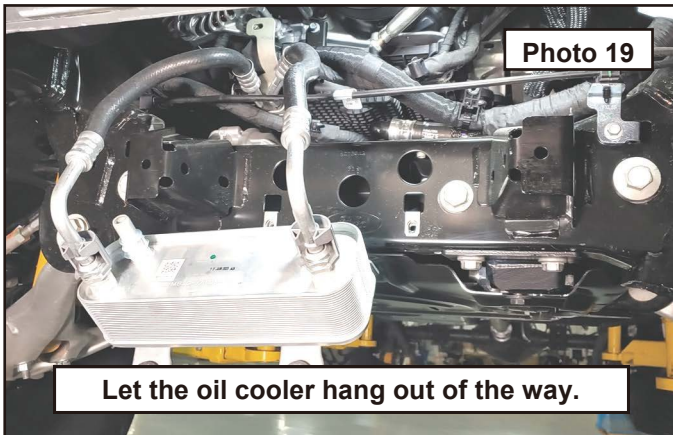

20. Repeat the process for both frame extensions. **Photo 21**

21. Sand any burrs and sharp edges smooth. Paint the exposed metal with a quality rust preventative paint. **Photo 22**

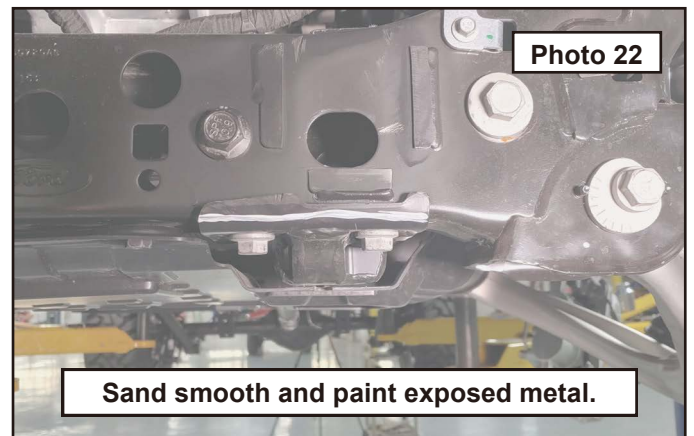
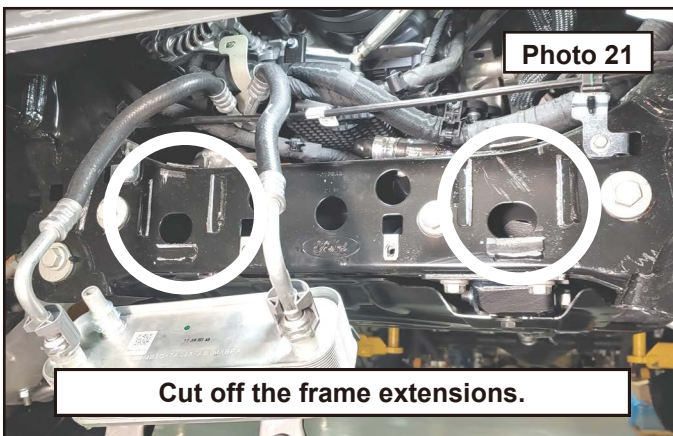

22. Use a flat head pry tool to open up the clamp holding the hard brake line to the frame. **Photo 23**

23. Remove the plastic mount from the metal bracket. Relocate the metal brake line into the rearmost recess on the plastic mount. Close the mount until it locks. **Photo 24**

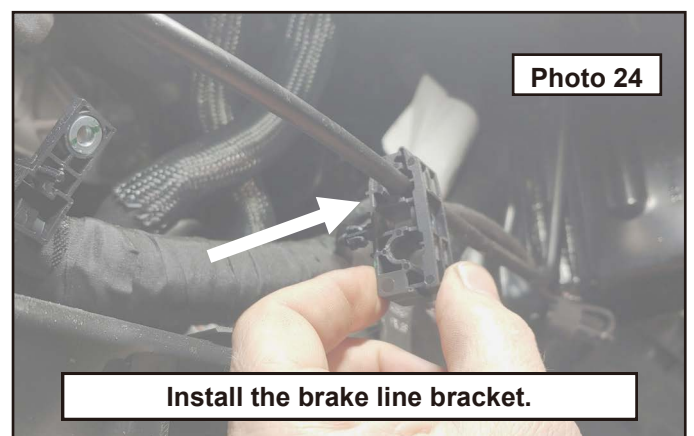
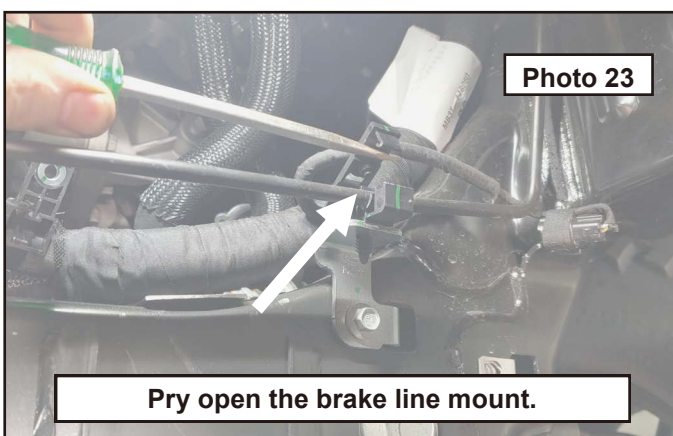

24. Remove the brake line metal bracket using a 10mm wrench. Save the bracket as you will reuse it later. **Photo 25**  
 25. Install the assembled boost pump and bracket to the frame in the place of the brake line bracket using the factory hardware. Set the assembly straight up and tighten the hardware. **Photo 26**

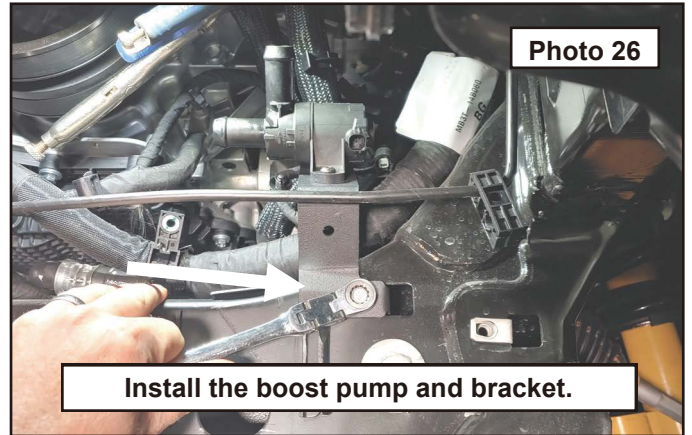
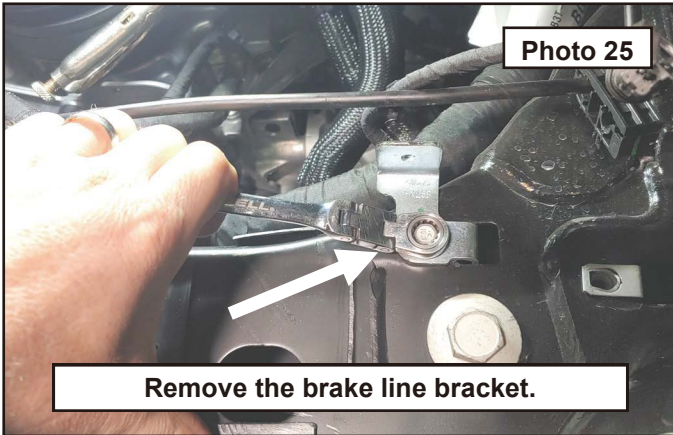

26. Install the brake line plastic mount to the boost pump bracket. **Photo 27**  
 27. Connect the boost pump electrical connector. **Photo 28**

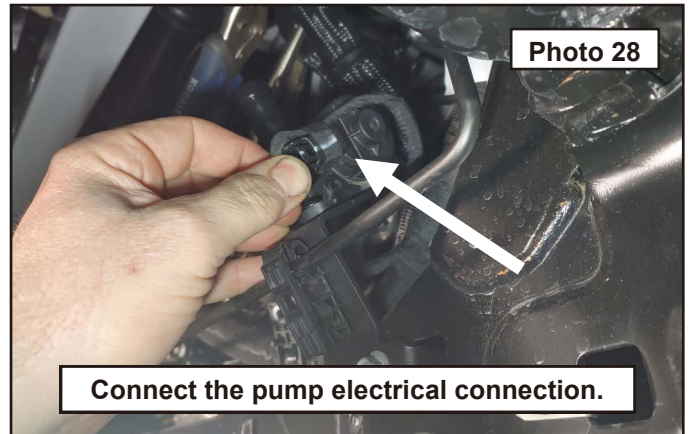
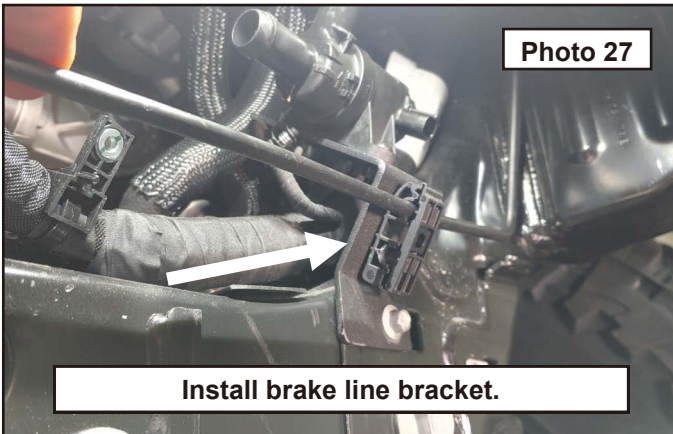

28. Make a mark on the core support 9" from the driver side frame rail. **Photo 29**  
 29. In the center of the made mark, drill out a hole in the core support using a 1/4" drill bit in preparation for a self threading bolt. **Photo 30**

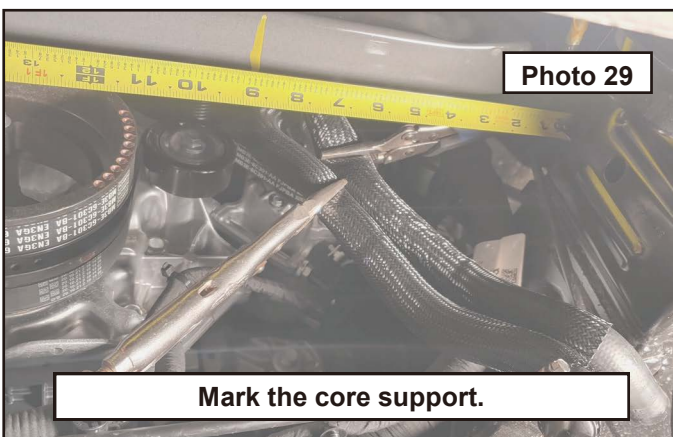

30. Locate the 5/16" self threading bolt in your hardware bag and use a impact driver to drive this bolt into the core support. Do not overtighten and strip the core support out. Remove the bolt after you have completed the threading process. Paint the exposed metal. **Photo 31**
31. Install the provided rubber isolated clamp to the passenger side coolant hose. You will need this clamp to sit above the core support when installed correctly. **Photo 32**

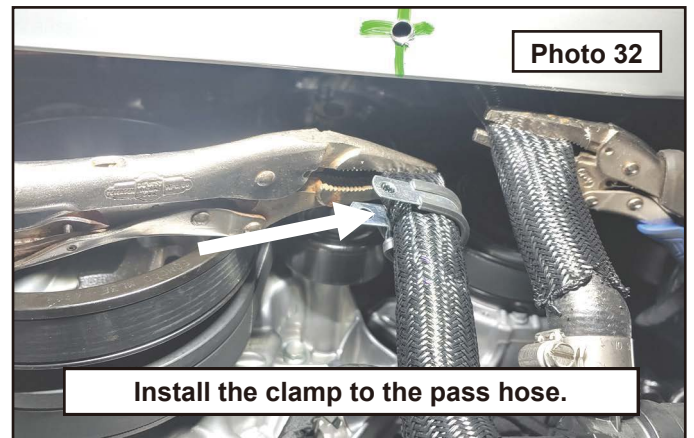

32. Install the previously removed brake line bracket to the clamp using the provided 6mm button head bolt and nut as shown. Make sure to use the small hole at the clamp leaving the large hole open. **Photo 33.**
33. Install the bracket to the core support using the self threading 5/16" bolt from the previous step. Look up into the engine bay following this coolant line. Make sure that it is not sitting on any moving components of the engine. Adjust the hose in the clamp as necessary to keep it clear of all components. **Photo 34**

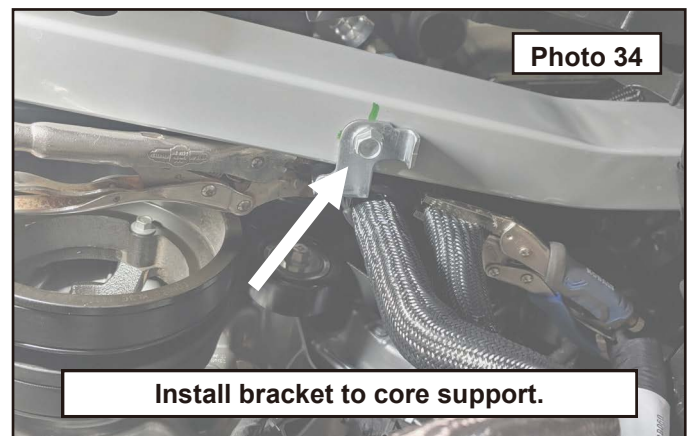
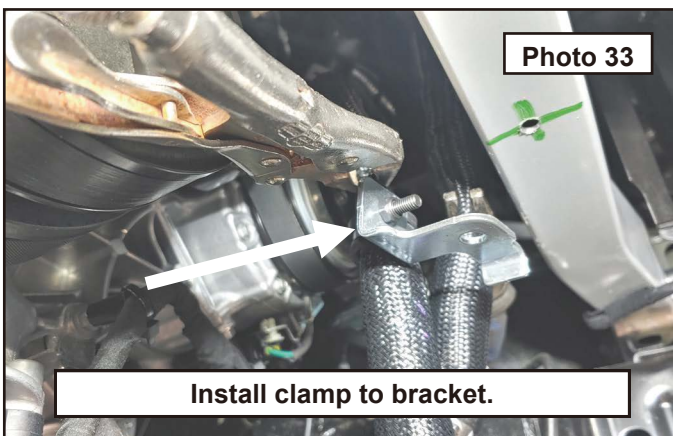

34. Pull the driver side coolant line down to the boost pump and make a mark even with the lowest position of the nipple. **Photo 35**
35. Use a suitable cutting tool to cut the hose at the mark. Cut back the plastic anti-wear sleeve to expose the rubber line. Use a lighter or micro torch to singe the sleeve to keep it from unraveling. Install the coolant line to the boost pump using the provided hose clamp. **Photo 36**

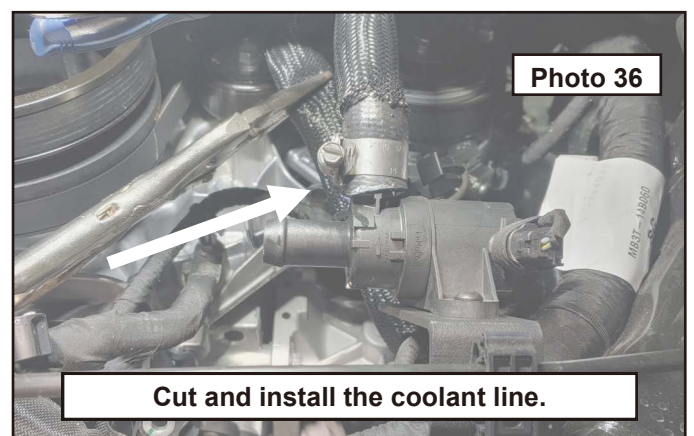
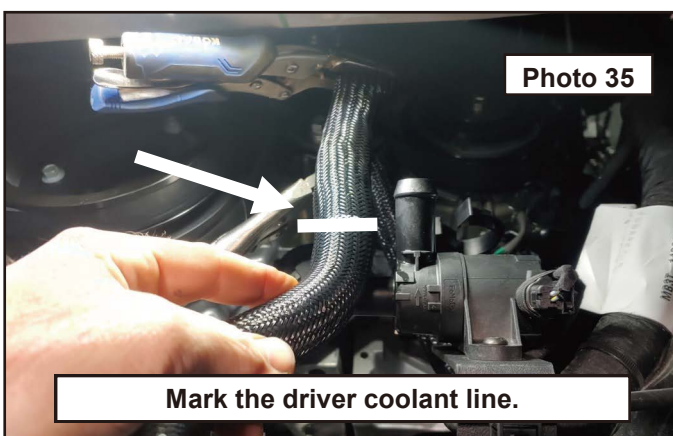

36. Mark a line on the passenger side coolant line 7.5" from the end of the crimp connection closest to the 90 degree fitting. Cut the line at the mark and do the same as before with the anti-wear sleeve. **Photo 37**
37. Place the cut off hose into a vice and use a suitable cutting tool (cut off disc shown) to cut through the crimp fitting. Make sure to not cut into the plastic fitting. Do this on two sides of the fitting. Pry the crimp fitting off the hose and pull the 90 degree fitting out of the hose. **Photo 38**

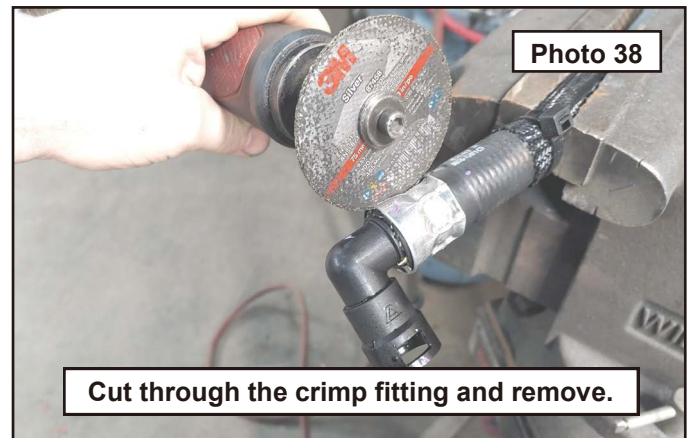
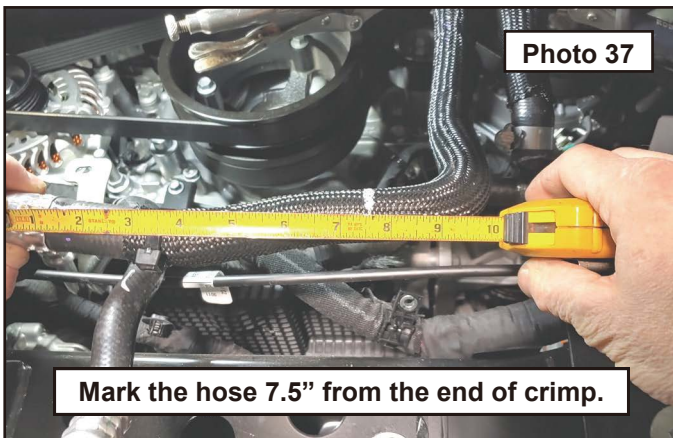

38. Install the 90 degree fitting into the cut hose using the provided hose clamp facing as shown. **Photo 39**
39. Rotate the oil cooler 180 degrees to get to the back mounts. You will be removing these from the cooler. **Photo 40**

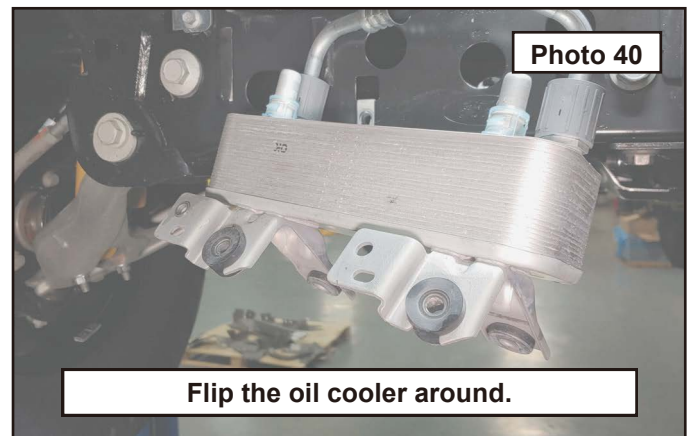
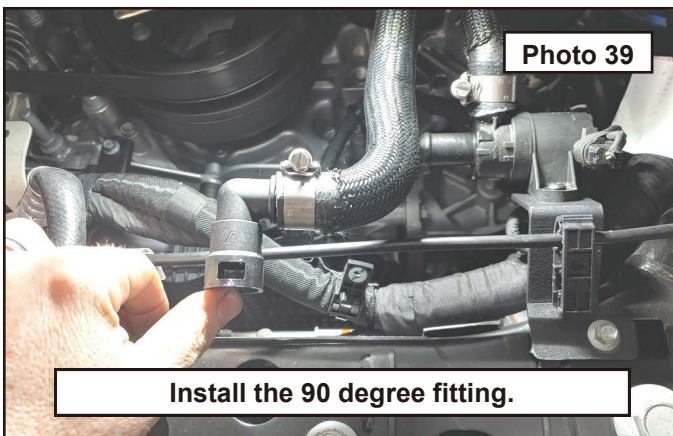

40. Use a suitable cutting tool (air body saw shown) to cut off both the upper mounts from the cooler. Do not cut into the cooler body. Sand any burrs smooth. **Photo 41**
41. Flip the cooler back around. Connect the passenger coolant line back to its original location while making sure to route the hose under the transmission line. **Photo 42**

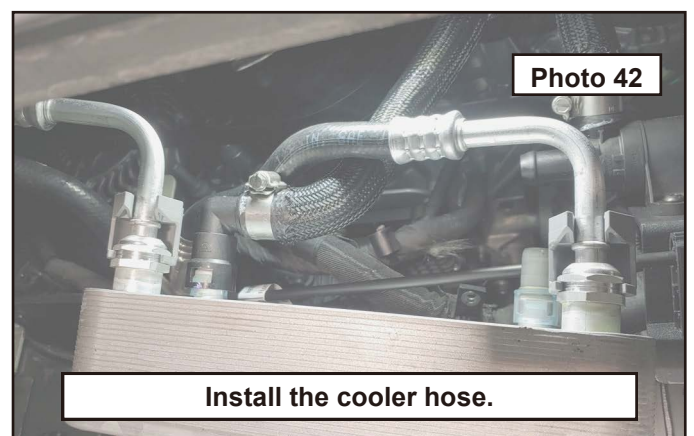
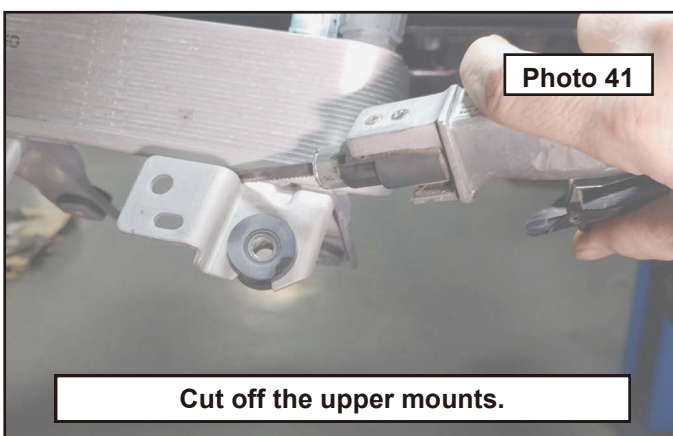



42. Install the original driver side coolant hose to the cooler. **Photo 43**

43. On the remaining cooler mounts, remove the metal crush sleeve and flip to the opposite side. Install the Rough Country oil cooler bracket to the cooler using the provided 8mm x 35mm bolts, washer and flange nut. **Photo 44**

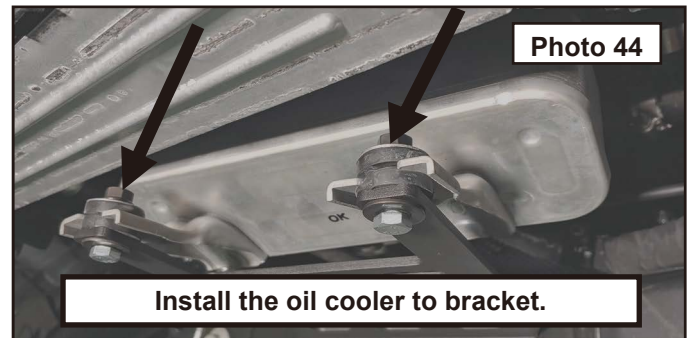
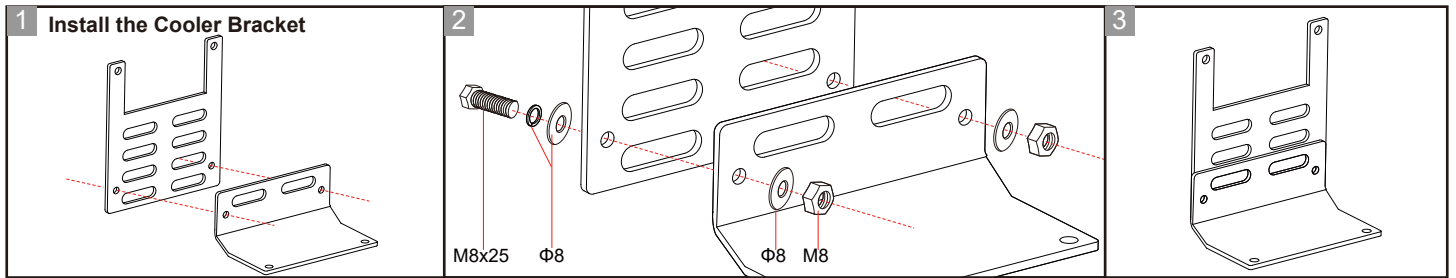

44. Install the Rough Country oil cooler bracket to the frame rail using the provided 8mm x 25mm black bolts and washers. **Photo 45**

45. Once the oil cooler is in position, route the remaining hose to the boost pump and mark it. Cut at the mark and remove the remaining anti-wear sleeving. **Photo 46**

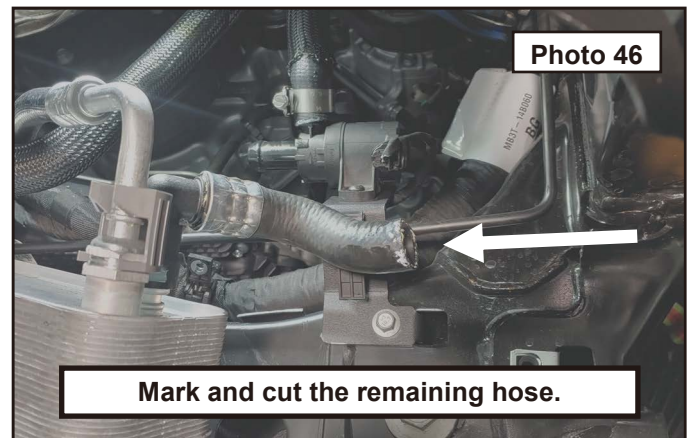
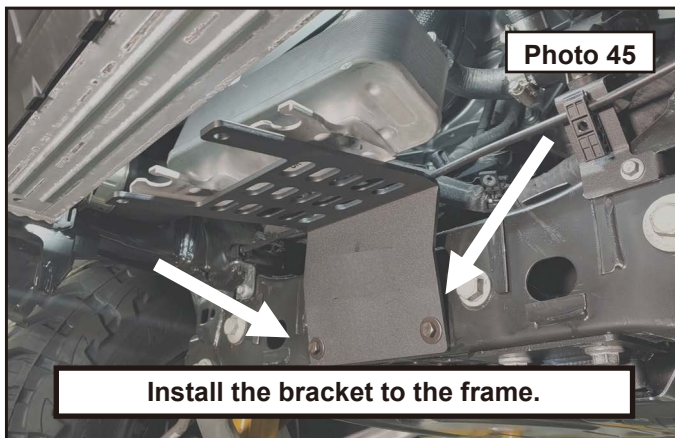

46. Install the hose to the boost pump using the provided hose clamp. Remove the locking pliers from the coolant hoses. Top off the coolant reservoir. Start the vehicle and check for leaks and for all hose clearances. **Photo 47**

47. Install the charge pipe back to the intake and intercooler. Make sure the spring clips lock into place. **Photo 48**

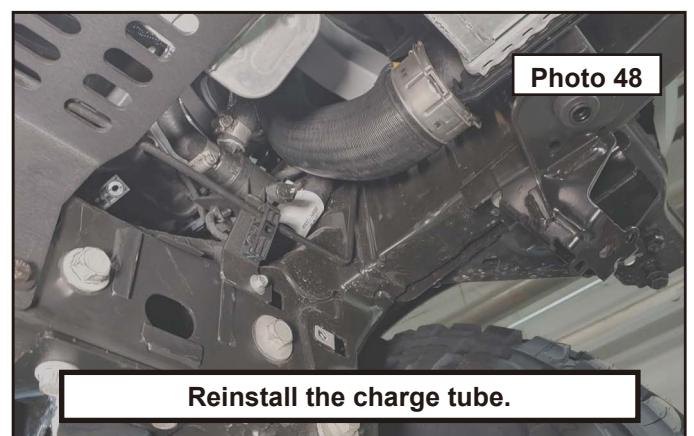
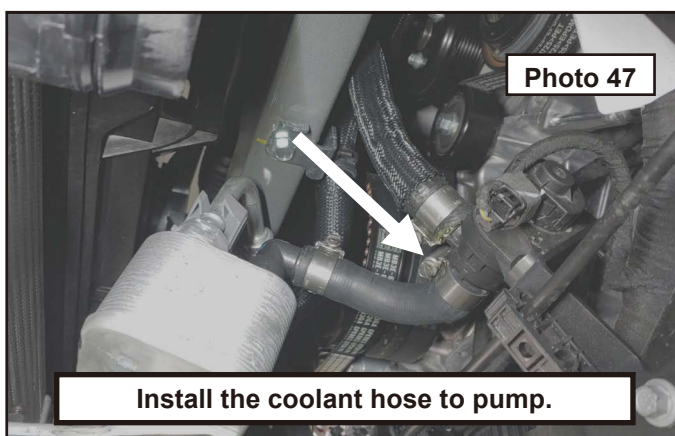

48. Locate the winch tray and the driver and passenger side mounts. **Photo 49**

49. Install the mounts to the tray using the provided 12mm bolts, washers and flange nuts as shown using a 18 and 19mm wrench. **Photo 50**

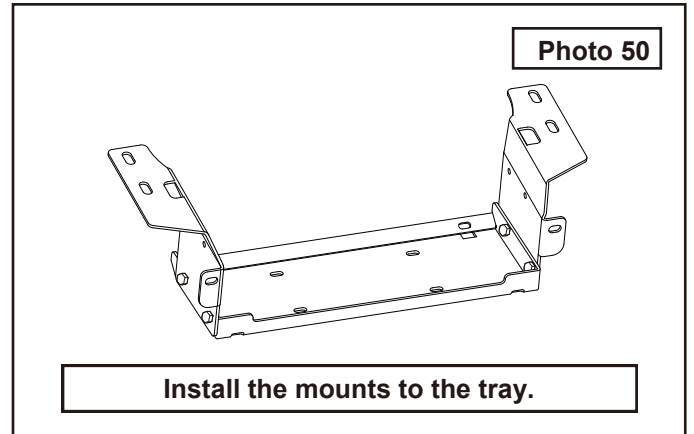
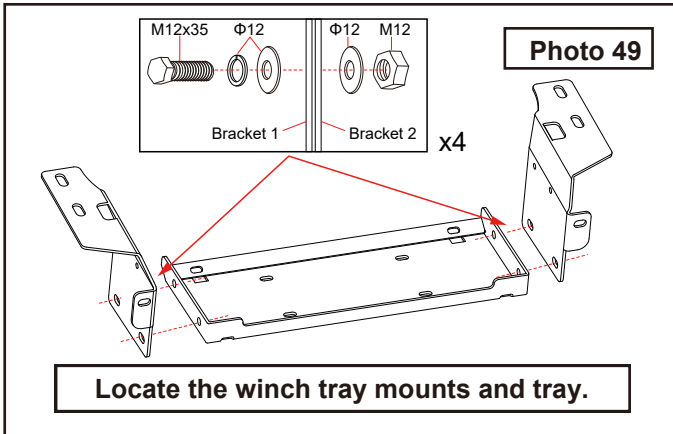

50. Install the winch to the winch tray using the hardware provided with the winch as shown. Leave the mounting hardware loose so that you can adjust later. It is easier to place the winch upside down and then install the tray to the winch. This kit was specifically designed around the RC 9500 and 12000 lb winch with synthetic rope and Hawes fairlead. **Photo 51 / 52**

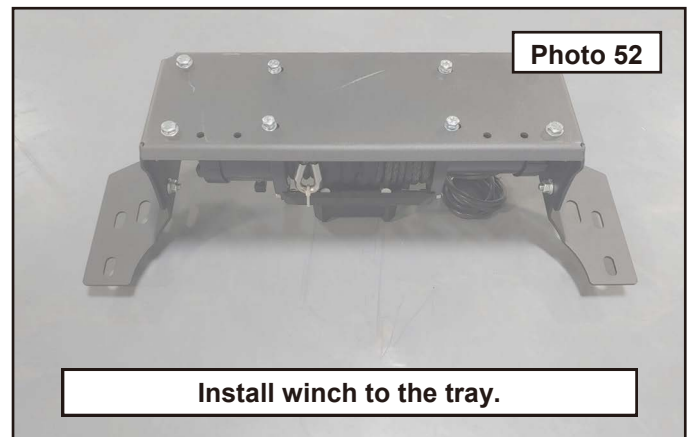
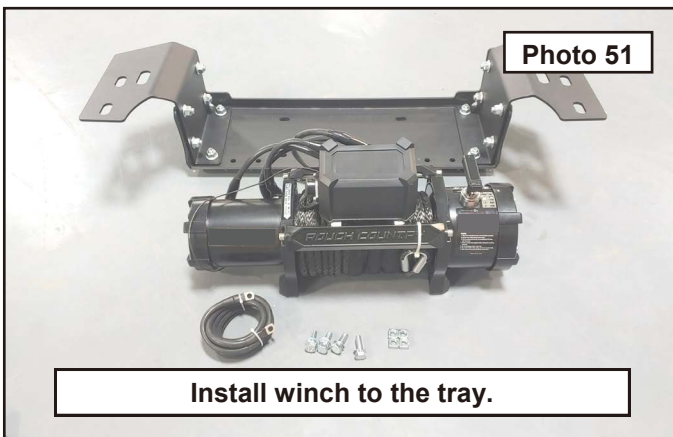

51. Flip the assembled winch tray over. The winch controller box needs to be relocated. Use a 2mm hex wrench to remove the set screws for the cross bar cover at the front of the winch. **Photo 53**

52. Once the cover is removed, slide the controller box forward to release the mounting brackets from the cross bars. **Photo 54**

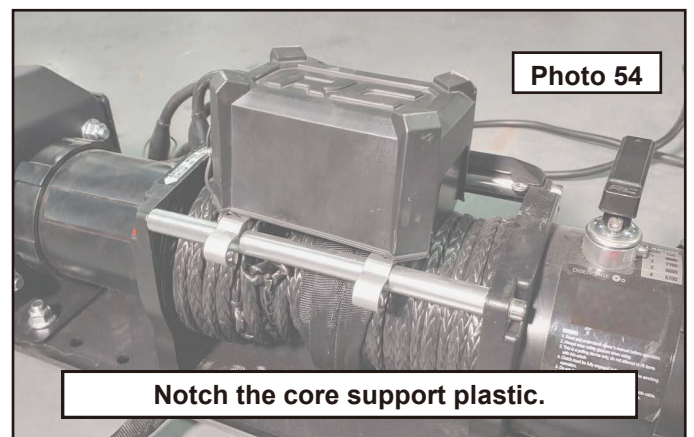
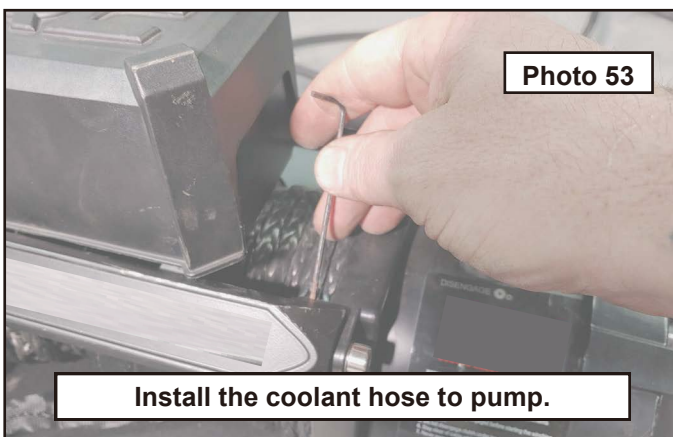

53. Flip the controller box over and remove the mounting brackets using a 10mm socket. **Photo 55**

54. Reinstall the cross bar cover. **Photo 56**

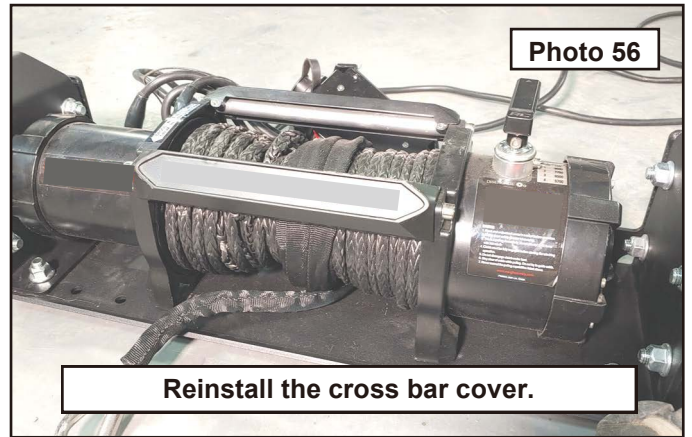
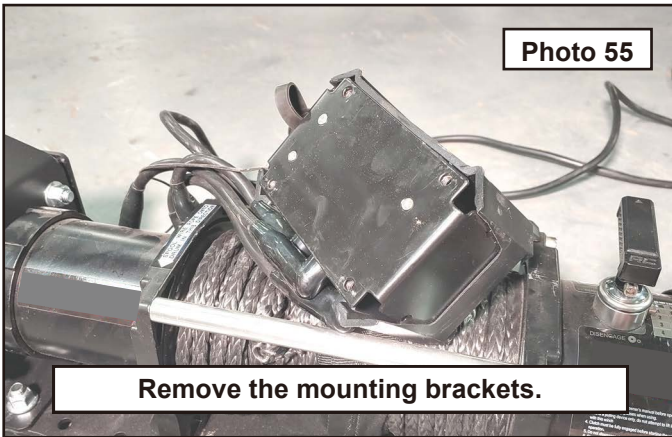

55. Install the winch controller to the Rough Country bracket as shown using the previously removed hardware. **Photo 57**

56. Install the assembled controller and bracket to the winch tray using the provided 10mm bolts, washers and flange nuts. Leave loose so that you can adjust at a later step. **Photo 58**

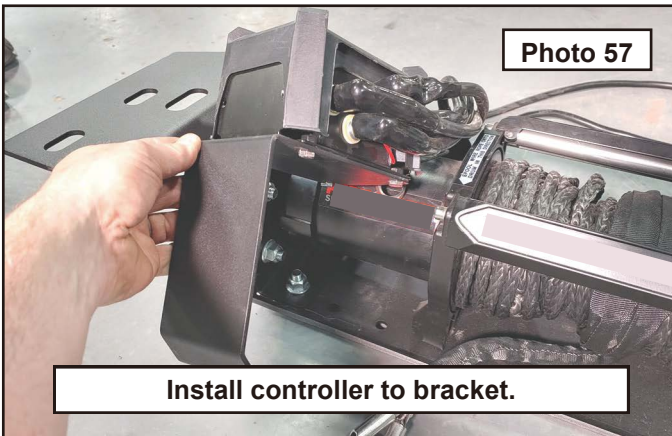

57. Install the winch controller extension to the control box. **Photo 59**

58. When installing the winch tray, pay close attention to the control box and winch handle when raising into place. Adjust the winch and the controller box bracket in their slotted holes to clear the oil cooler if needed. Fully tighten the hardware. **Photo 60**

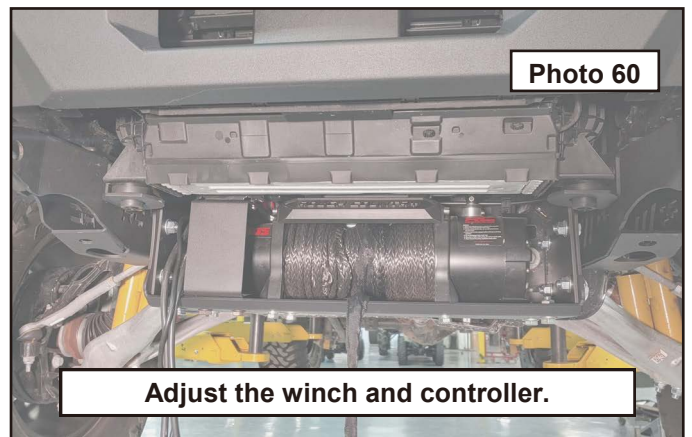
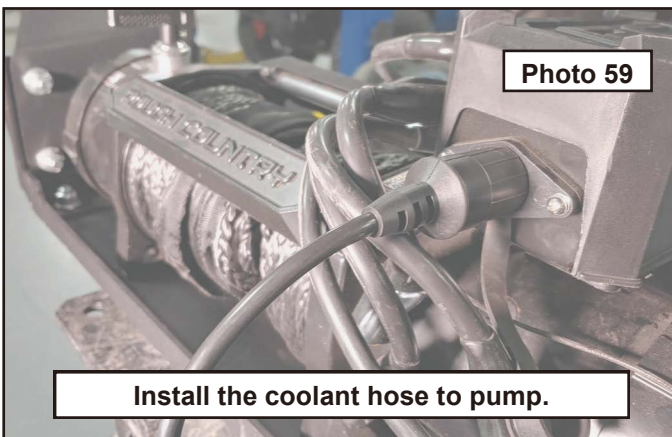

Plastic bumper and Rough country fabricated bumper: Skip back to page 5, step 11 to finish your installation.  
Factory Modular bumper: Skip back to page 10, step 15

