

# FRONT INNER FENDER FLARES

————— User Manual —————

2018-2022 Wrangler JL

2019-2022 Jeep Gladiator JT

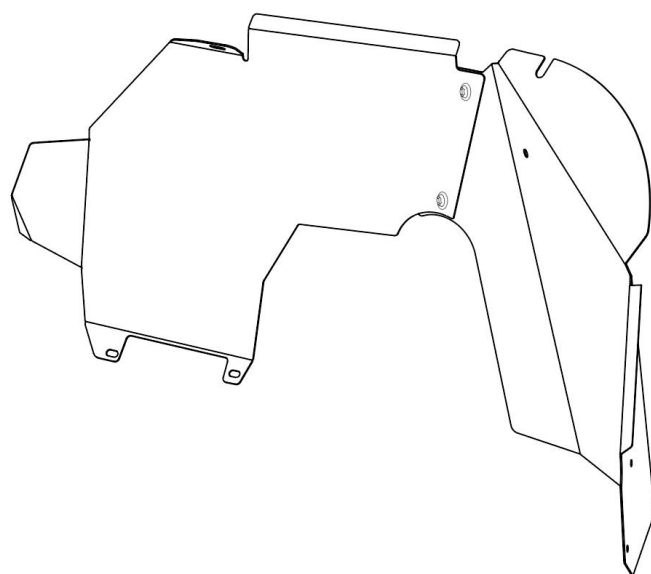

Model:	NJL01G104-F
Material:	Q235A
Product Dimensions:	36.22 x 19.68 x 9.05 inch
Package Dimensions:	36.95 x 12.68 x 17.6 inch
Product Weight:	19.29 lbs

---

※ Thank you for purchasing the FRONT INNER FENDERS. Please read this manual carefully and keep it properly if you need to refer to it afterward. If you need any support or assistance, please contact us with your product model number and order number, and our support team will help you solve problems.





**⚠ WARNING**

※ This product is designed primarily to enhance the appearance of the vehicle. Do not rely in any way on the components of this product to protect against injury or death in the event of an accident. To reduce the risk of serious injury or property damage, please read all safety messages and understand all instructions and procedure notices before attempting to install or use this product.







**⚠ CAUTION**

※ Properly torque and recheck fasteners and security of step tread after 250 miles and inspect frequently. Do not use if damaged.

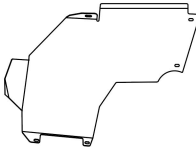
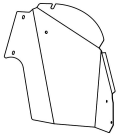
# REQUIRED TOOLS

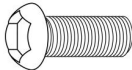
<b>Socket</b> 	<b>Ratchet</b> 	<b>Allen Wrench</b> 	<b>Safety Glasses</b> 
--	---	--	--

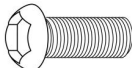
## Parts Information

Parts NO.	Parts Name	Size	Line Graph	Qty	Color
/	Front Inner Fender Flares 1	/		2	Black
/	Front Inner Fender Flares 2	/		2	Black
N08	Hex Flange Nuts	M6		12	SUS304
B08	Half Head Allen Bolts	M6 x 20		12	SUS304
W08	Spring Washer	Φ6		12	SUS304
W38	Flat Washer	Φ6x18x1mm		12	White Zinc
B14	Half Head Allen Bolts	M8x20		6	SUS304
W18	Flat Washer	Φ8x24x2mm		6	SUS304
W15	Spring Washer	Φ8		6	SUS304

**\*Note: spare parts such as N08、B08、W08、W38、B14、W18、W15 are provided with 2PCS each (included in the number of parts details).**

# Installation Instructions

**Step 1:** Open the carton and take out the parts. Check whether the number of components is complete.







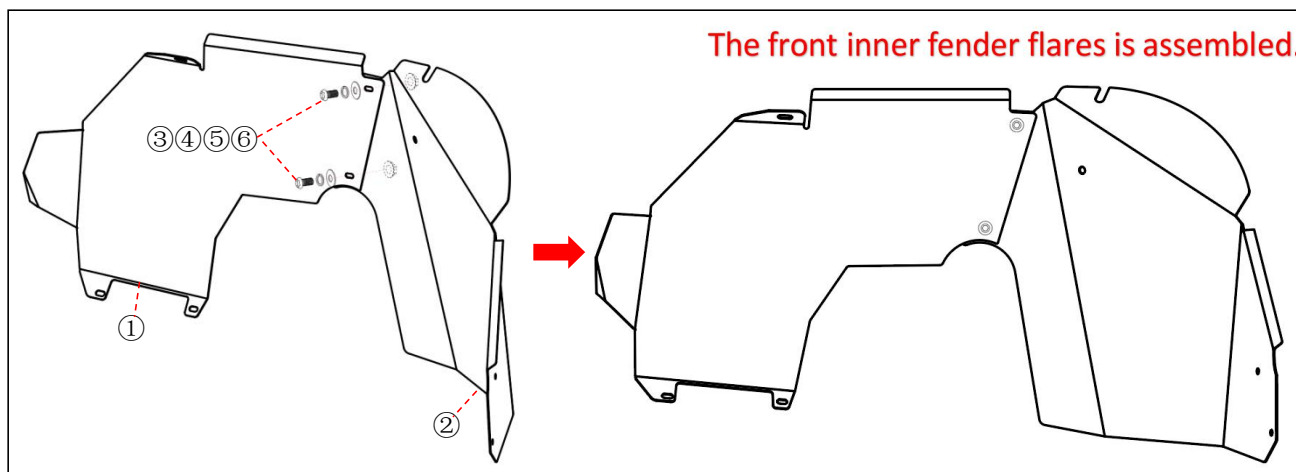
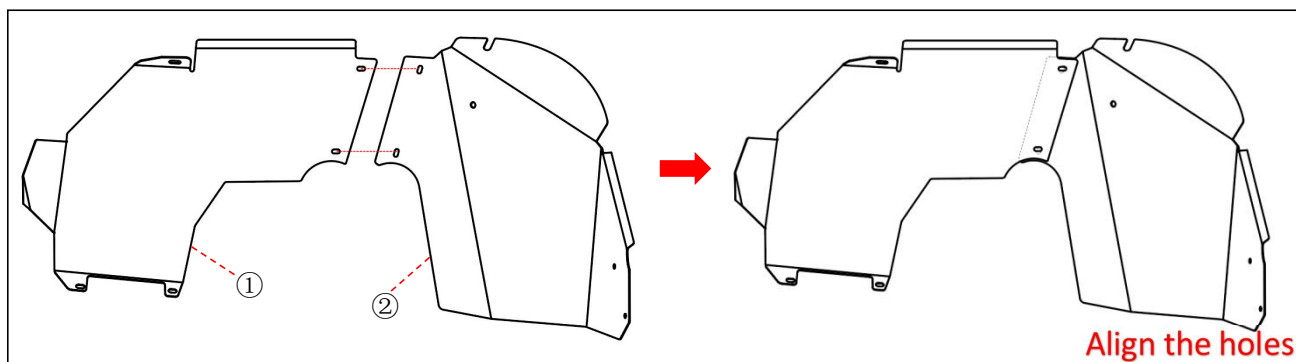
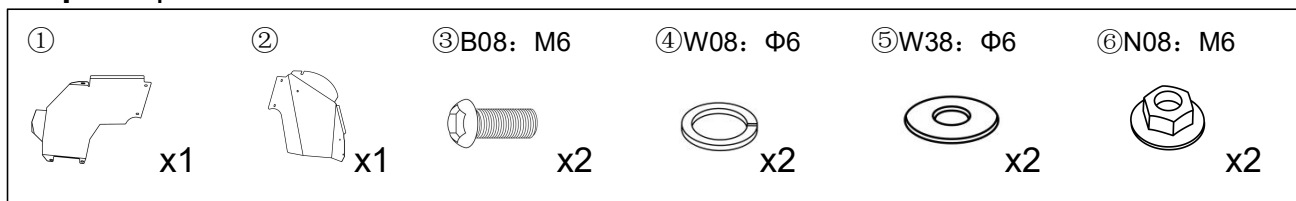

**Step 2:** Remove the original front fender flares and original front inner fender flares and prepare the parts needed to install the Front Inner Fender Flares.

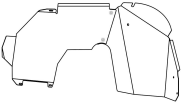

**Step 3:** Splice the front inner fender flares.



### Step 4: Install the front inner fender flares.

①  x1	②B08: M6  x3	③W08: Φ6  x3	④W38: Φ6  x3	⑤N08: M6  x3
⑥B14: M8  x2	⑦W15: Φ8  x2	⑧W18: Φ8  x2		

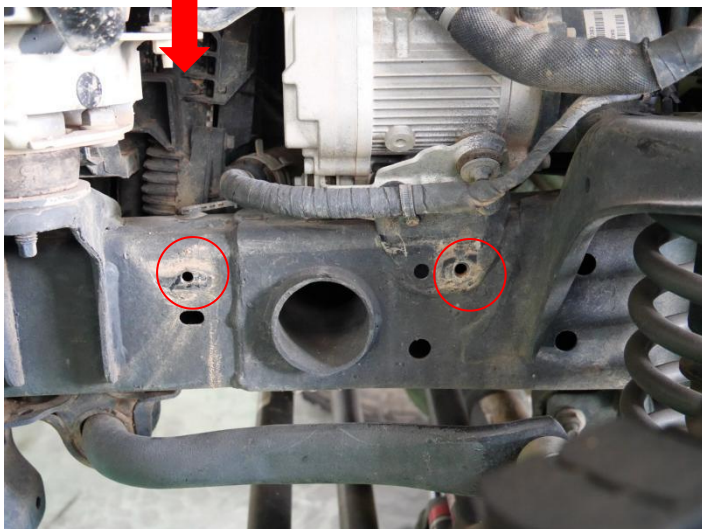

Mounting Holes

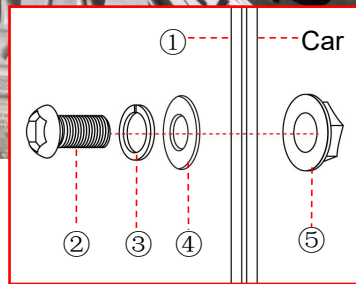
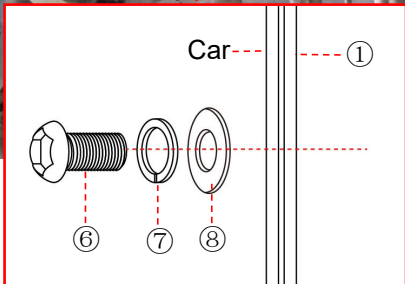
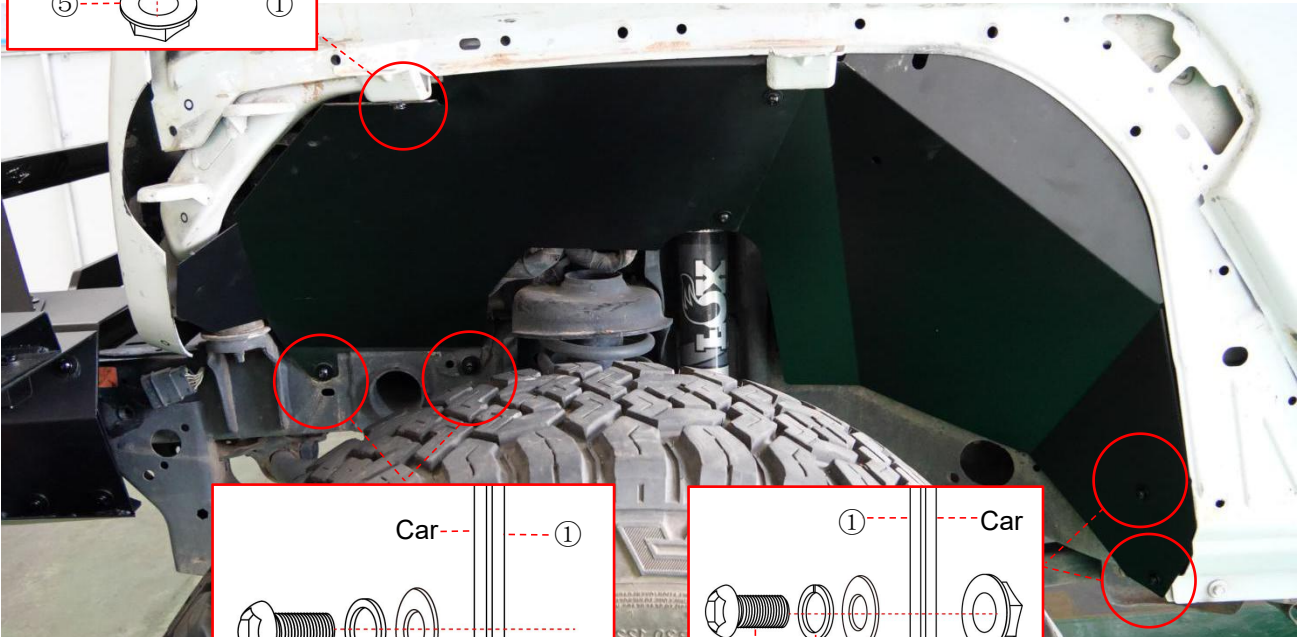
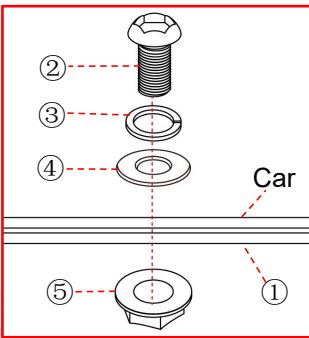
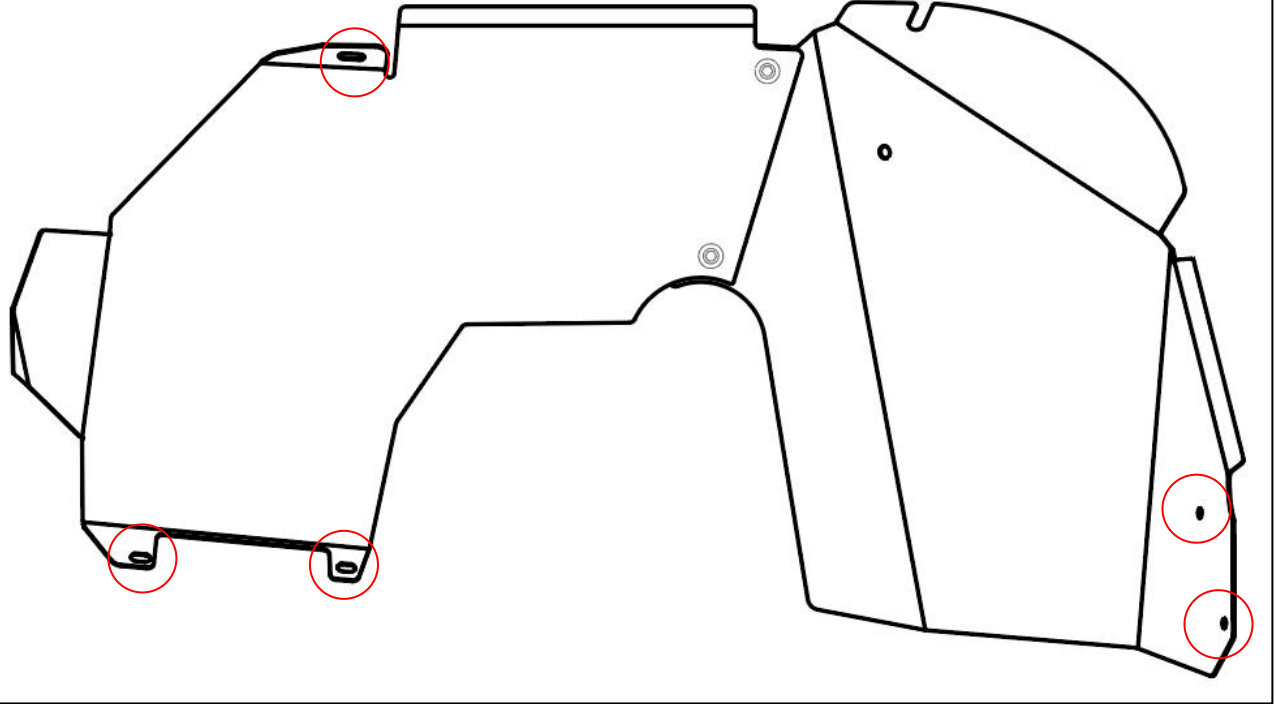



**Step 5:** Tighten all the bolts and nuts.

**Step 6:** Installation of a front inner fender flares is complete. Please do periodic inspections of the inner fender flares to make sure that all hardware is secure and tight.

**Step 7:** Install the original front fender flares.



# REAR INNER FENDER FLARES

————— User Manual —————

2018-2023 Wrangler JL



Model:	NJL01G104-R
Material:	Q235A
Product Dimensions:	39.2 x 13.3 x 21.8 inch
Package Dimensions:	45.3 x 22 x 89.8 inch
Product Weight:	21.83 lbs



---

※ Thank you for purchasing the REAR INNER FENDER FLARES. Please read this manual carefully and keep it properly if you need to refer to it afterward. If you need any support or assistance, please contact us with your product model number and order number, and our support team will help you solve problems.





**⚠ WARNING**

※ This product is designed primarily to enhance the appearance of the vehicle. Do not rely in any way on the components of this product to protect against injury or death in the event of an accident. To reduce the risk of serious injury or property damage, please read all safety messages and understand all instructions and procedure notices before attempting to install or use this product.





**⚠ CAUTION**

※ Properly torque and recheck fasteners and security of step tread after 250 miles and inspect frequently. Do not use if damaged.

# REQUIRED TOOLS

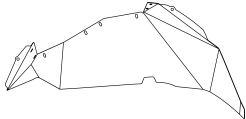
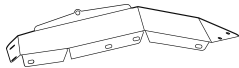
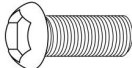
<b>Socket</b> 	<b>Ratchet</b> 	<b>Allen Wrench</b> 	<b>Safety Glasses</b> 
--	---	--	--

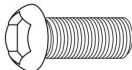
## Parts Information

Parts NO.	Parts Name	Size	Line Graph	Qty	Color
/	Rear Inner Fender Flares 1	/		2	Black
/	Rear Inner Fender Flares 3	/		2	Black
B05	Half Head Allen Bolts	M6 x 10		16	Dacro Black
N09	Hex Flange Nuts	M6		16	Dacro Black
B07	Half Head Allen Bolts	M6x20		8	Dacro Black
W13	Flat Washer	Φ6x18x1mm		22	Dacro Black
W09	Spring Washer	Φ6		8	Dacro Black

**\*Note: spare parts such as B05、N09、B07、W13、W09 are provided with 2PCS each (included in the number of parts details).**

# Installation Instructions

**Step 1:** Open the carton and take out the parts. Check whether the number of components is complete.

**Step 2:** Splice the rear inner fender flares.

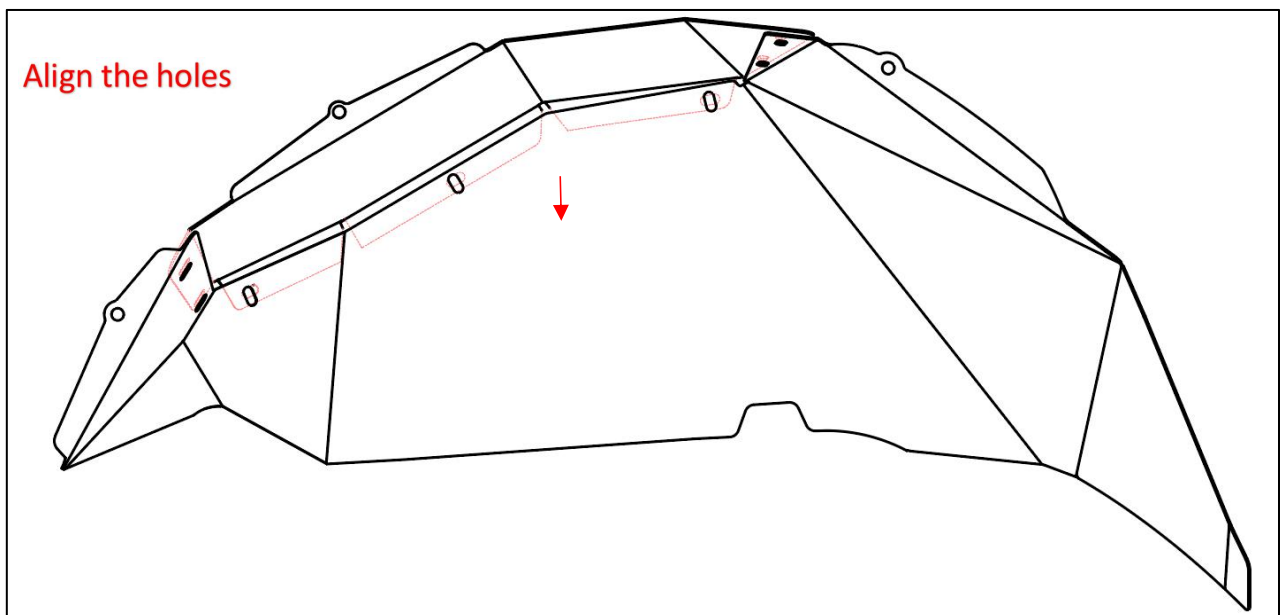
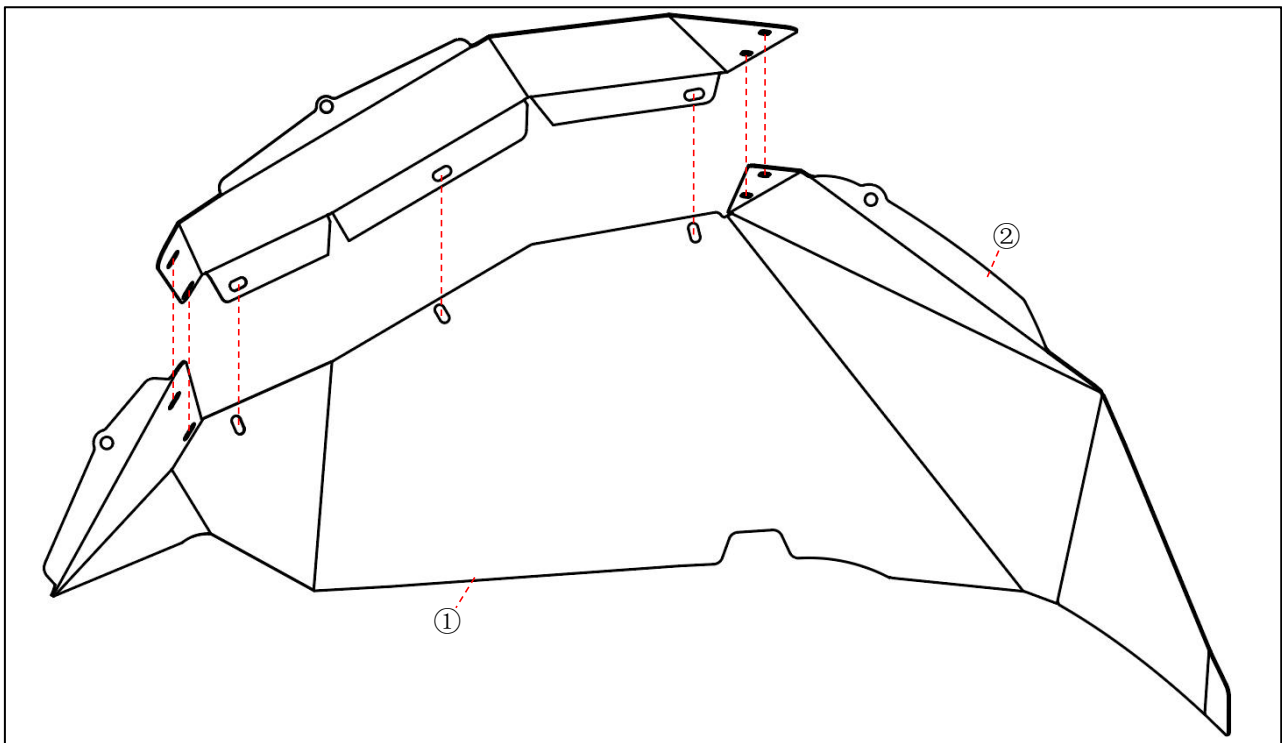
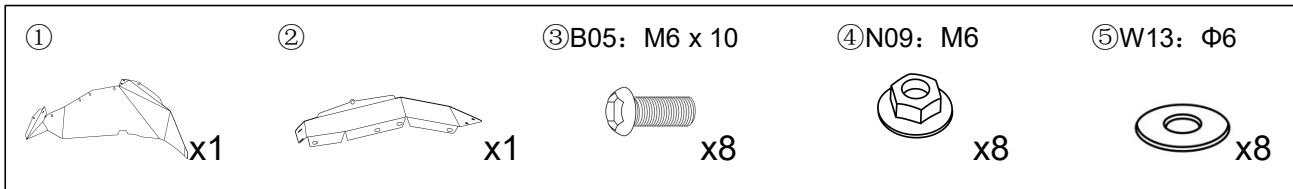

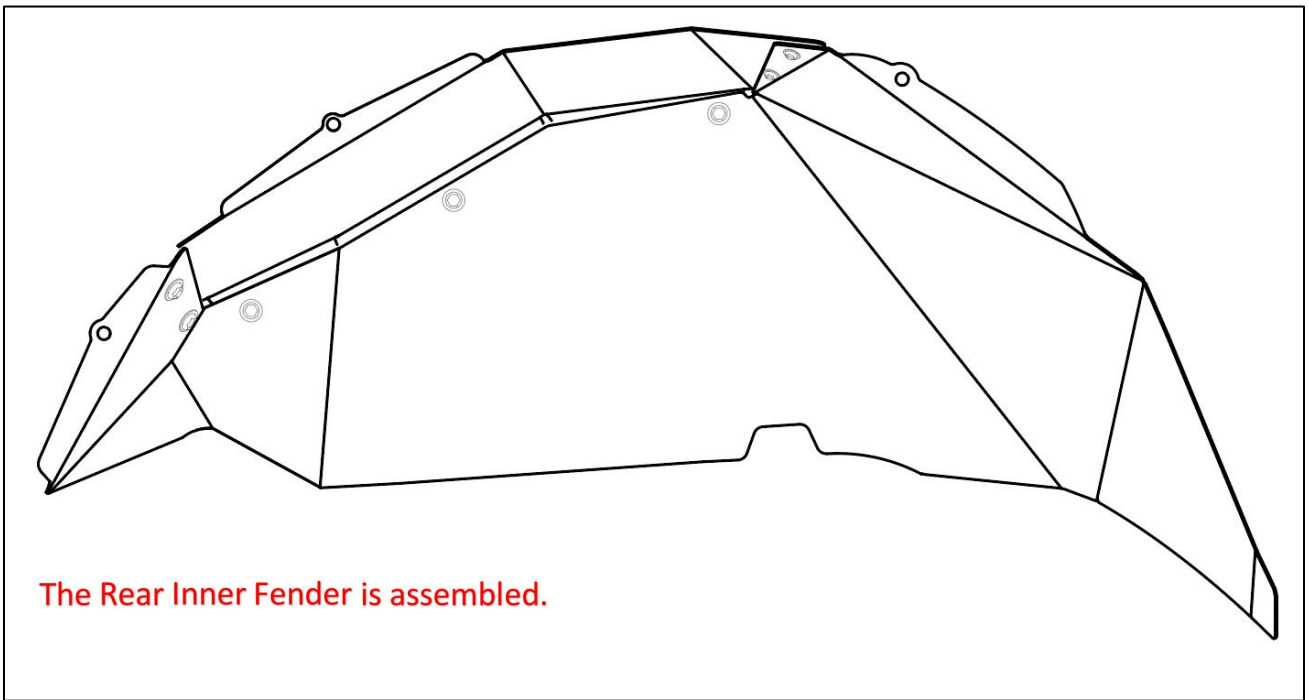
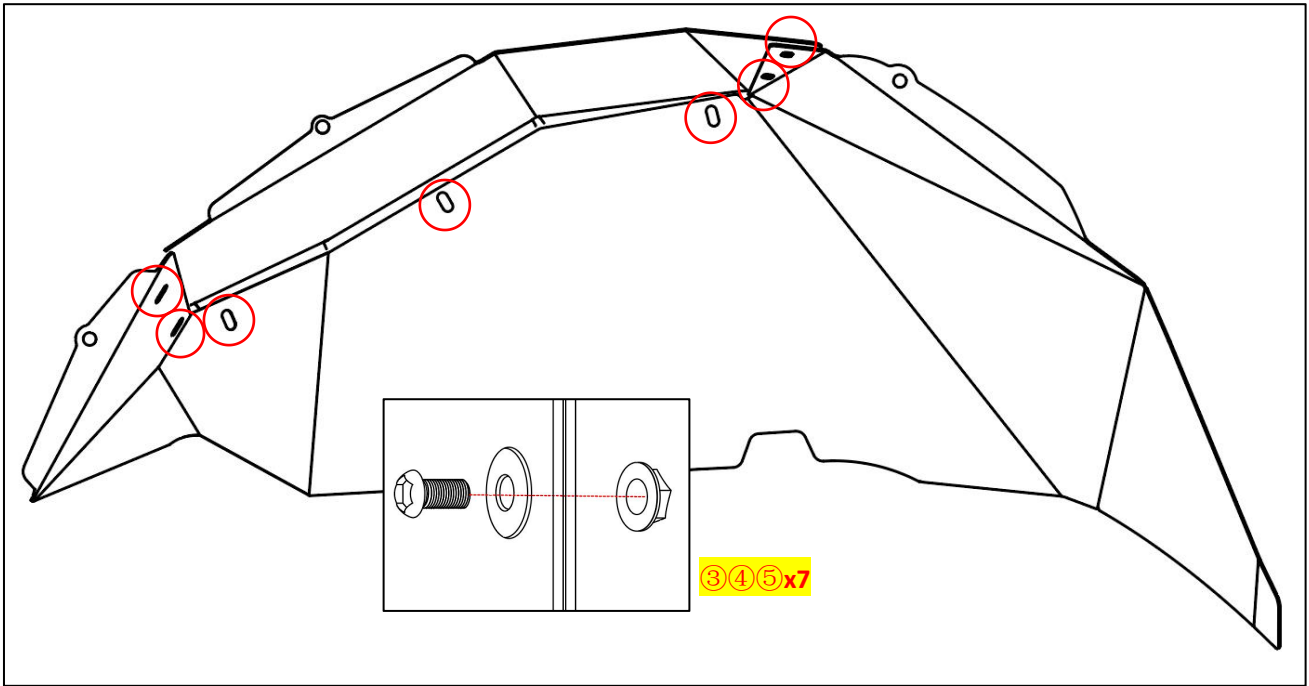

**NOTICE:** Do not tighten the bolts in this step.

**Step 4:** Splice the rear inner fender flares.

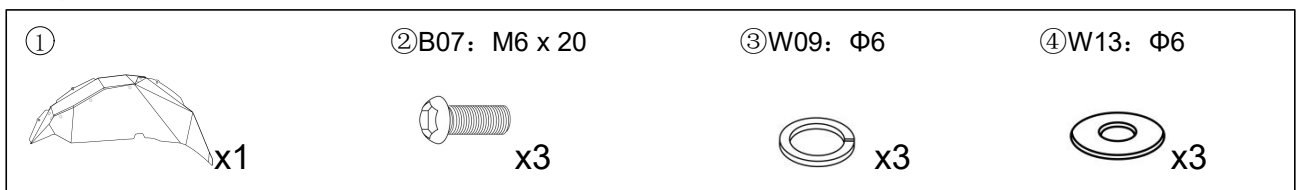

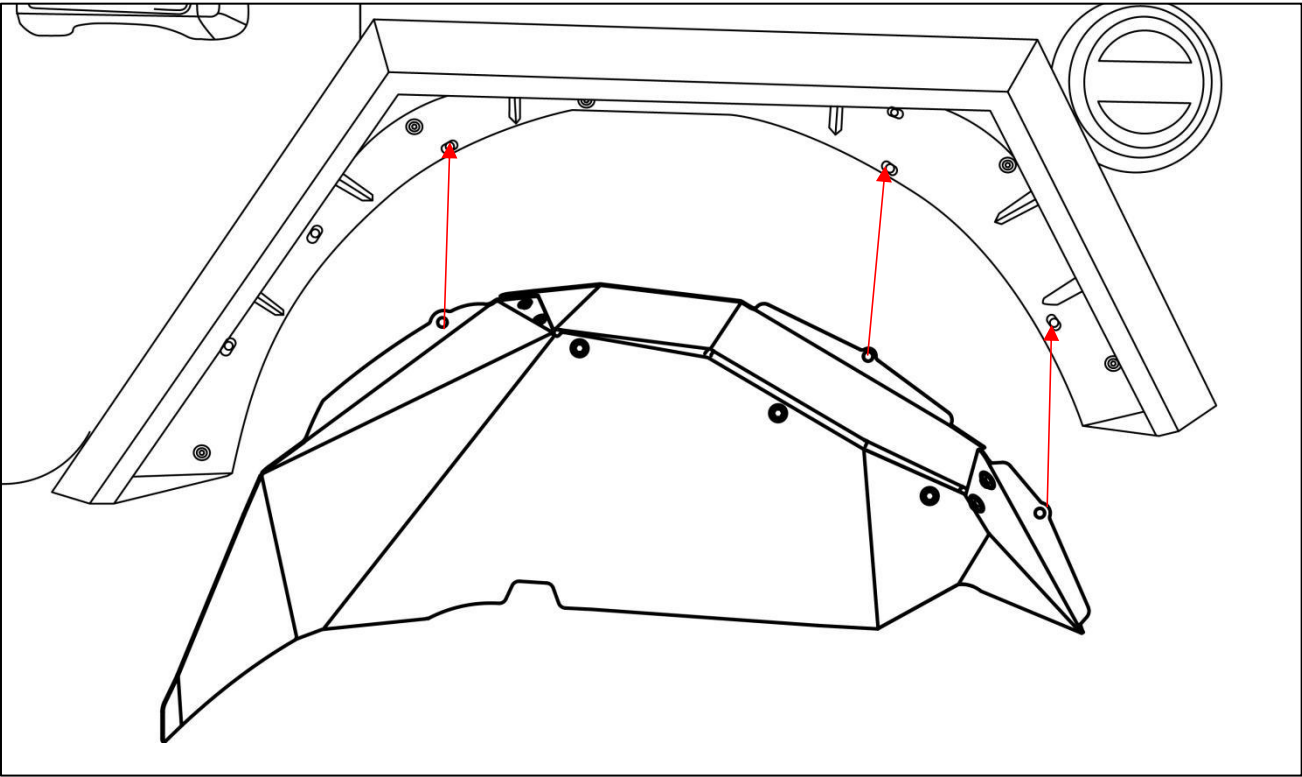
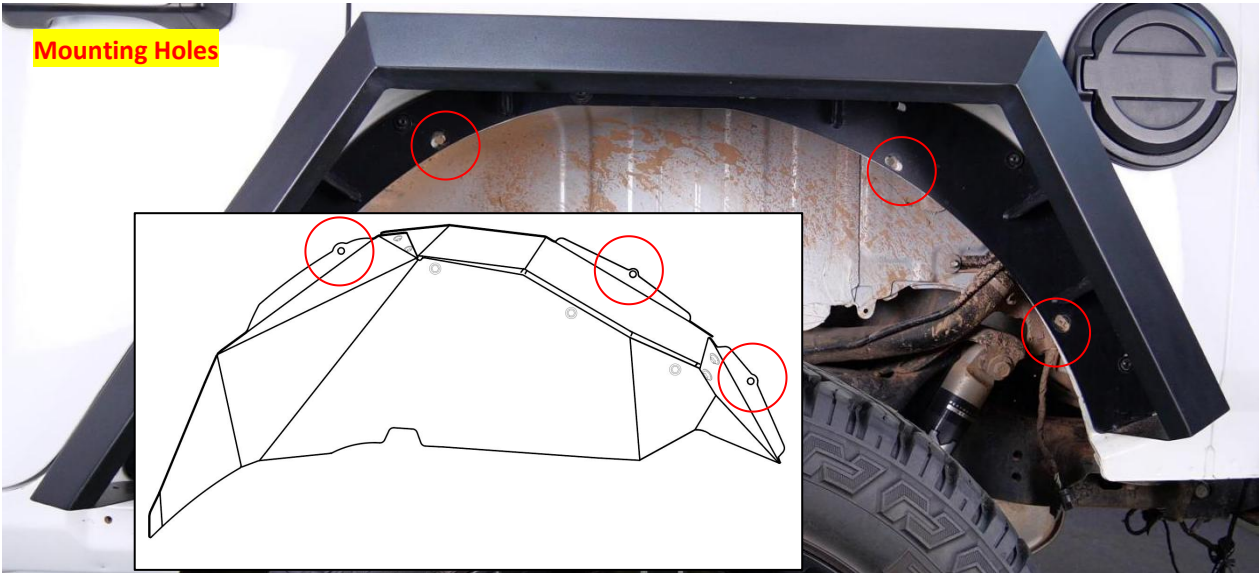



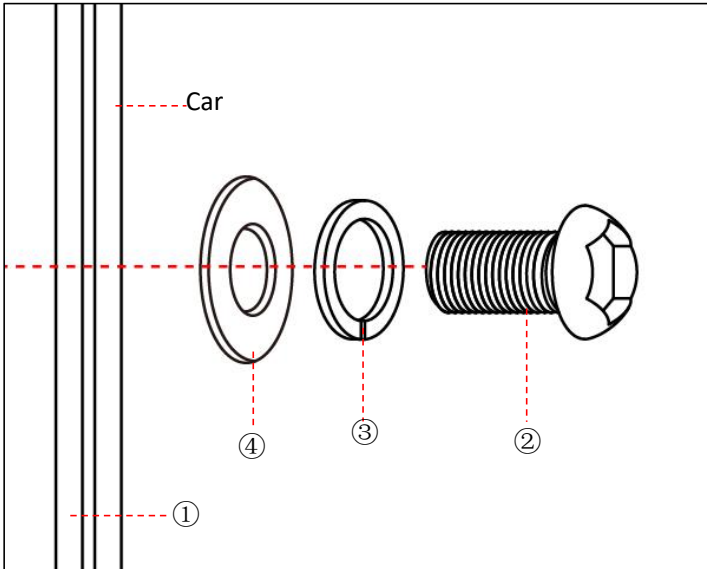

**Step 5:** Tighten all the bolts and nuts.

**Step 6:** Installation of a rear inner fender flares is complete. Please do periodic inspections of the rear fenders to make sure that all hardware is secure and tight.

**Note:** Please choose according to the situation of your car

**Step 7:** Install the original rear fender flares back on the car.