

REAR BUMPER

————— User Manual —————

2009-2018 Ram 1500



| | |
|---------------------|------------------------|
| Model: | NRM01B104 |
| Material: | Q235A |
| Product Dimensions: | 76.2 x 11 x 16.85 inch |
| Package Dimensions: | 73.6 x 13.4 x 12 inch |
| Product Weight: | 82.4 lbs |

※ Thank you for purchasing the REAR BUMPER. Please read this manual carefully and keep it properly if you need to refer to it afterward. If you need any support or assistance, please contact us with your product model number and order number, and our support team will help you solve problems.







⚠ WARNING

※ This product is designed primarily to enhance the appearance of the vehicle. Do not rely in any way on the components of this product to protect against injury or death in the event of an accident. To reduce the risk of serious injury or property damage, please read all safety messages and understand all instructions and procedure notices before attempting to install or use this product.





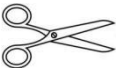





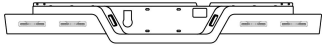

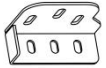
⚠ CAUTION

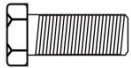
※ Properly torque and recheck fasteners and security of step tread after 250 miles and inspect frequently. Do not use if damaged.

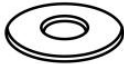
※ Rear Bumper is heavy, and we strongly suggest the assistance of an able-bodied assistant during the lifting and installation of your Rear Bumper.

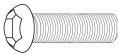
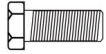
| REQUIRED TOOLS | | | |
|--|---|--|--|
| Socket  | Safety Glasses  | Wrench  | Allen Wrench  |
| Ratchet  | Scissors  | Masking tape  | Plastic trim tool  |

Parts Information

| Parts NO. | Parts Name | Size | Line Graph | Qty | Color |
|-----------|-----------------------|----------|--|-----|-------------|
| / | Bumper | / |  | 1 | Black |
| / | Left/Right Bumpers | / |  | 2 | Black |
| / | Brackets | / |  | 2 | Black |
| / | Plates | / |  | 2 | Black |
| B35 | Hex Bolts | M10x35 |  | 14 | Dacro Black |
| W22 | Spring Washer | Φ10 |  | 14 | Dacro Black |
| W23 | Flat Washer | Φ10x25x2 |  | 26 | Dacro Black |
| N15 | Hex Nuts | M10 |  | 14 | Dacro Black |
| B19 | Half Head Allen Bolts | M8x25 |  | 6 | Dacro Black |
| B20 | Hex Bolts | M8x25 |  | 16 | Dacro Black |
| W16 | Spring Washer | Φ8 |  | 20 | Dacro Black |
| W19 | Flat Washer | Φ8x24x2 |  | 34 | Dacro Black |
| N22 | Hex Nuts | M8 |  | 20 | Dacro Black |
| / | Ribbon | 5x250 |  | 20 | Black |

***Note: spare parts such as B35、W22、W23、N15、B19、B20、W16、W19 and N22 are provided with 2PCS each (included in the number of parts details).**

Installation Instructions

Step 1: Open the carton and take out the parts. Check whether the number of components is complete.

Step 2: Remove the original bumper and prepare the parts needed to install the bumper.

Step 3: Splicing the Bumper.

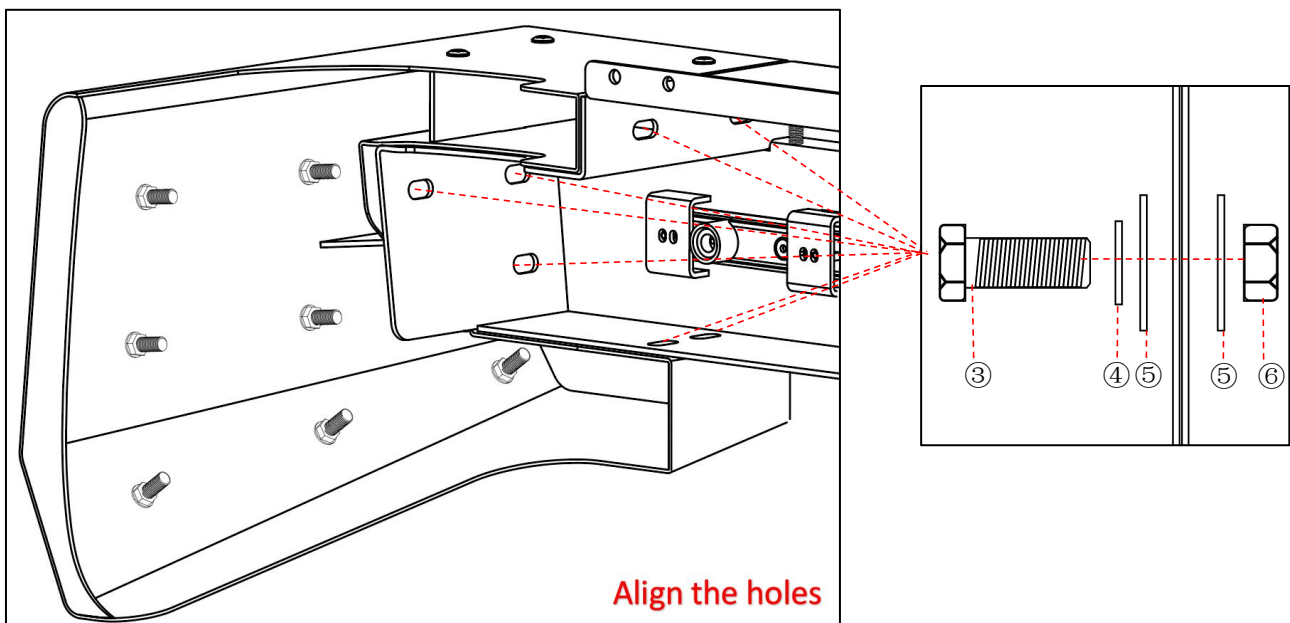
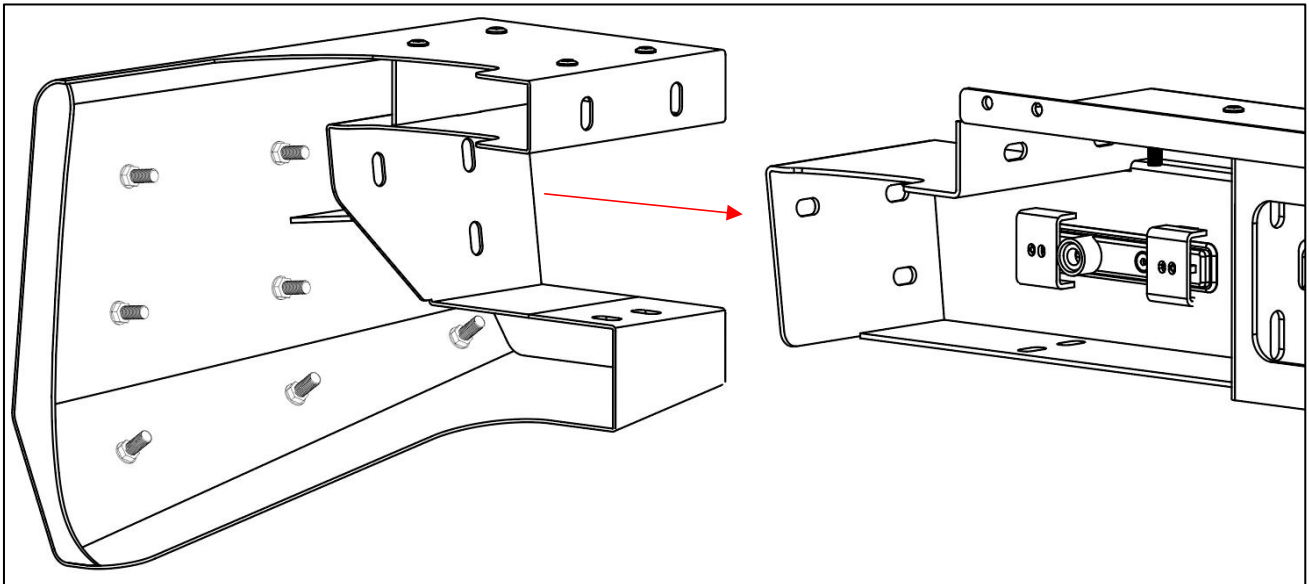
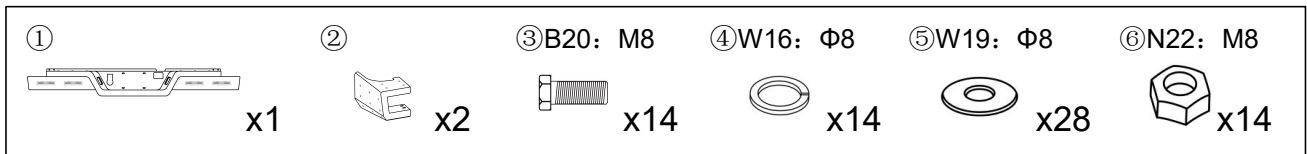

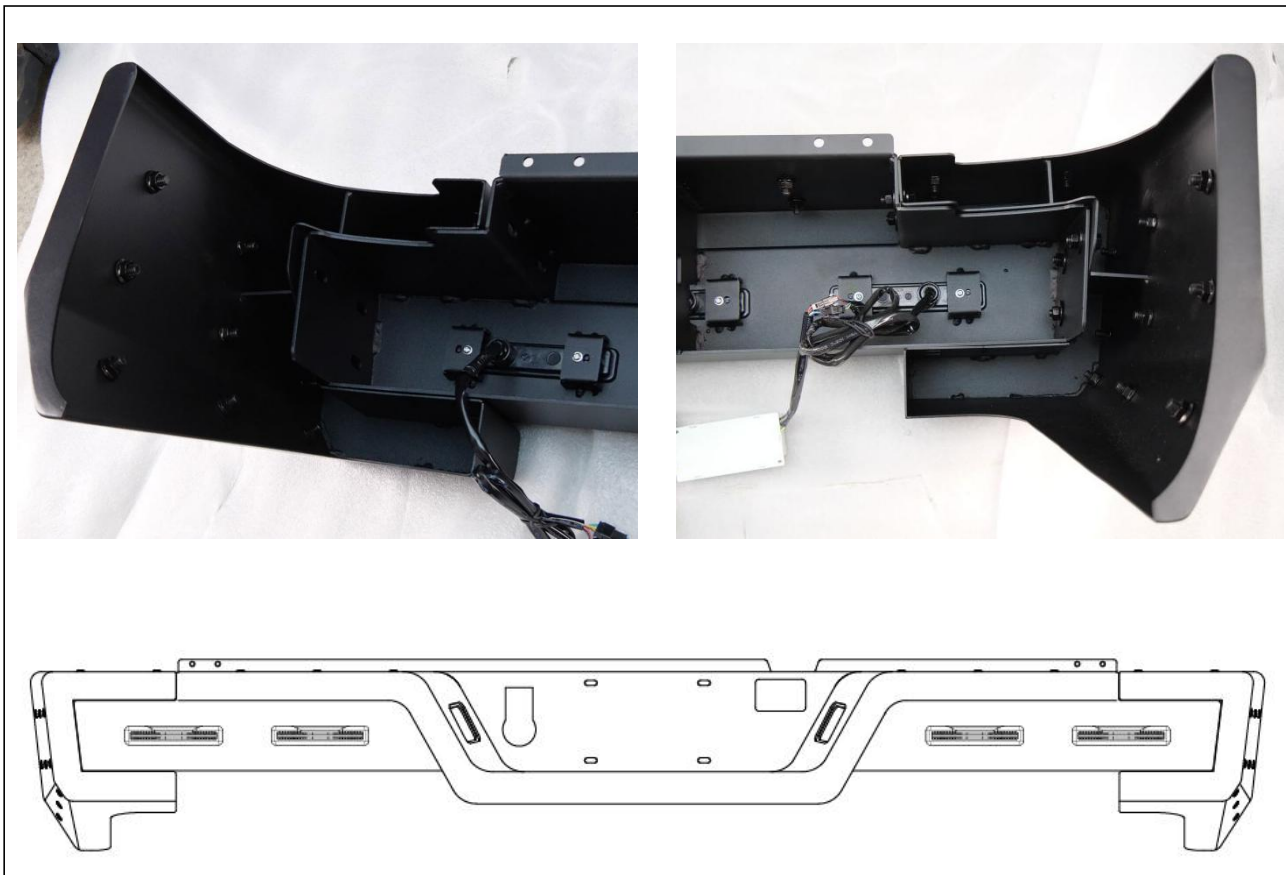



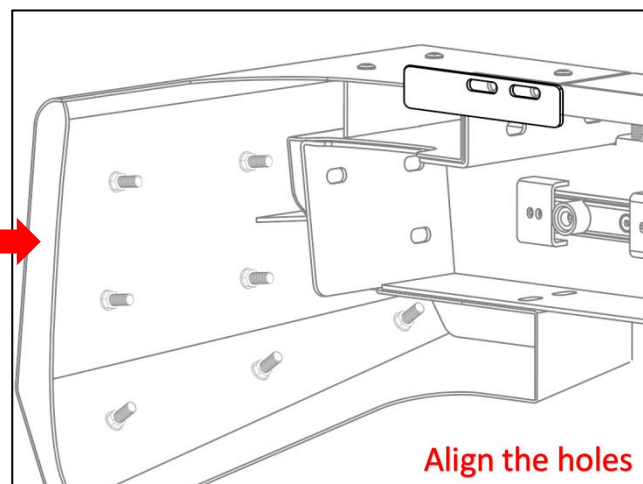
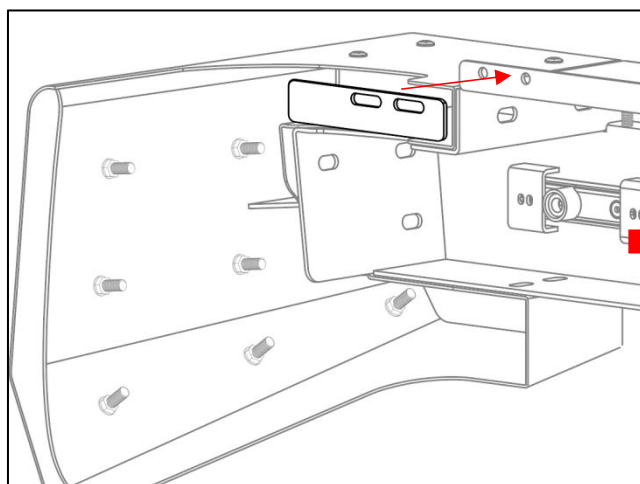
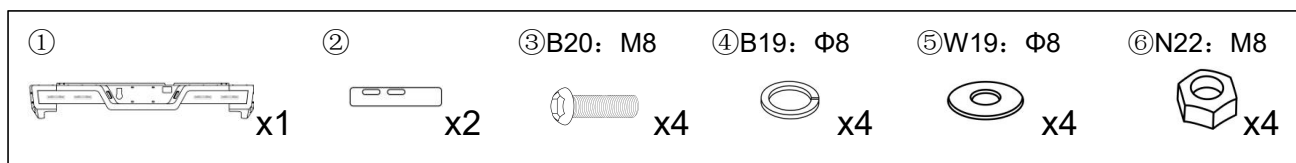

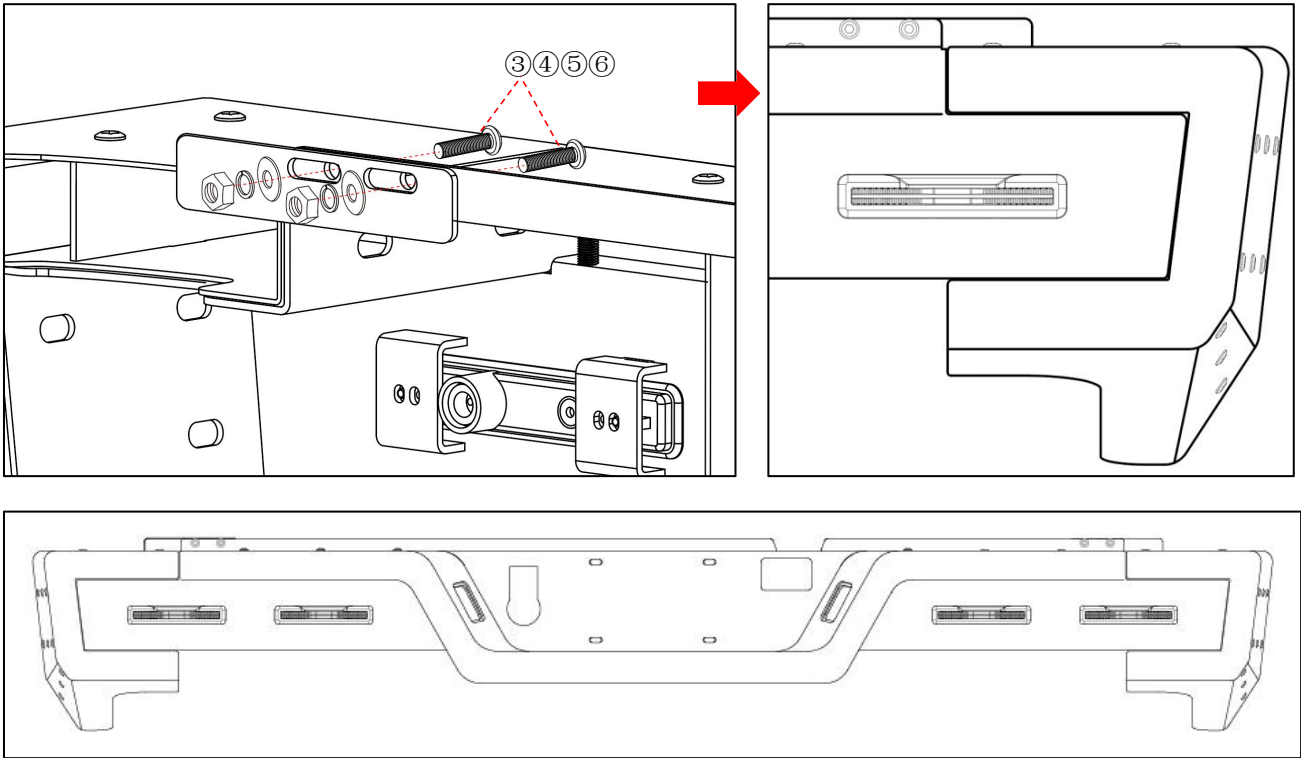

Step 4: Install the Plate.

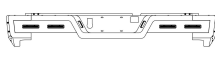





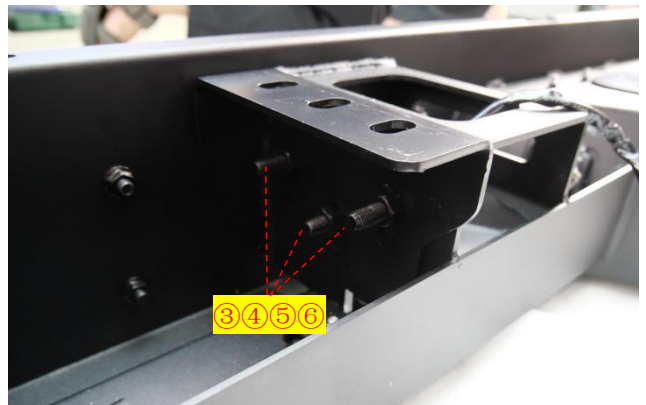
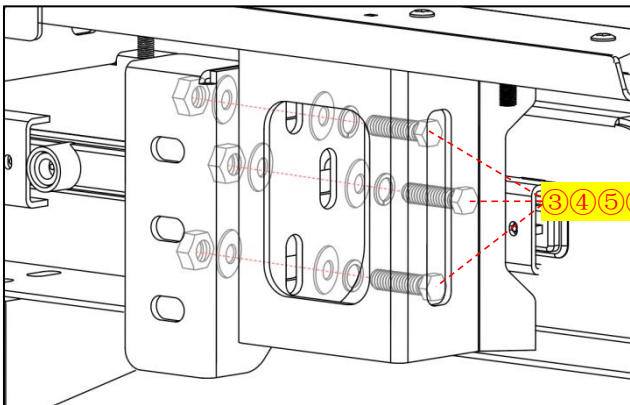

Step 5: Install the Bracket.

- | | | | | | |
|--|--|---|---|---|---|
| ① | ② | ③ B35: M10 | ④ W22: $\Phi 10$ | ⑤ W23: $\Phi 10$ | ⑥ N15: M10 |
|  x1 |  x2 |  x12 |  x12 |  x24 |  x12 |



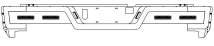

Step 6: Install the bumper.

| | | | | |
|--|---|---|---|---|
| ① | ②B35: M10 | ③W22: $\Phi 10$ | ④W23: $\Phi 10$ | ⑤N15: M10 |
|  x1 |  x12 |  x12 |  x24 |  x12 |

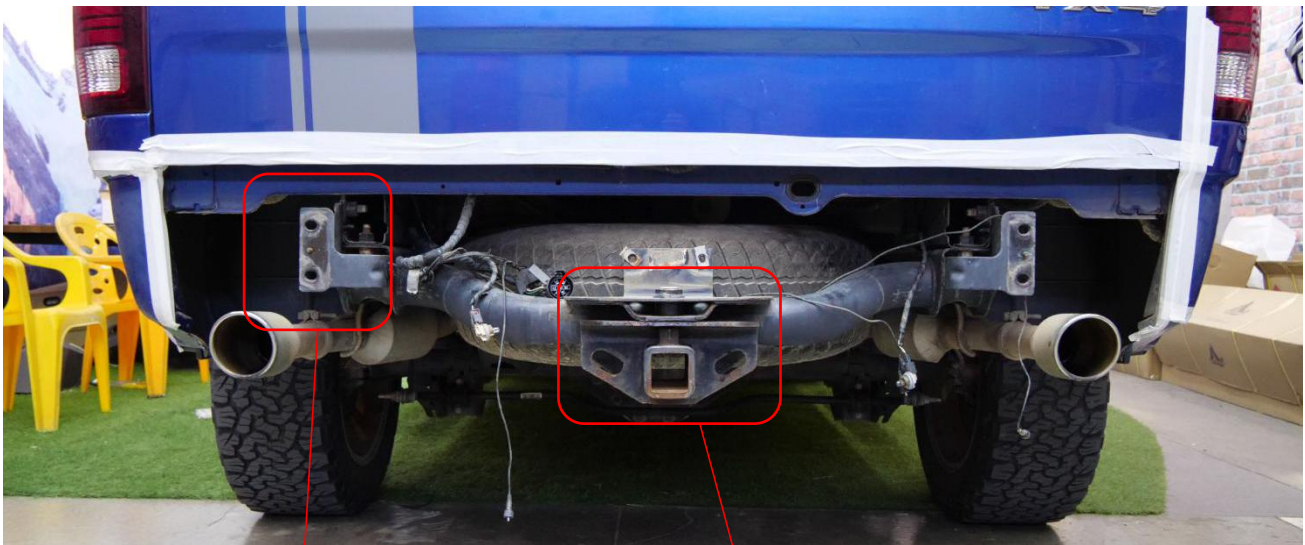

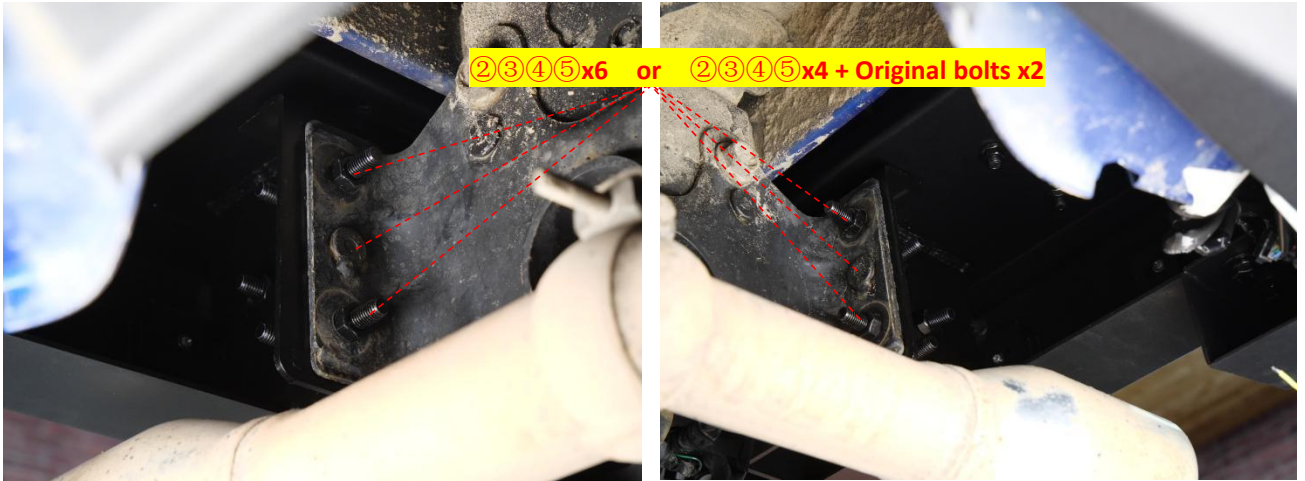

Step 7: Connect the bumper brake light wiring.



Remove the screws and take care.

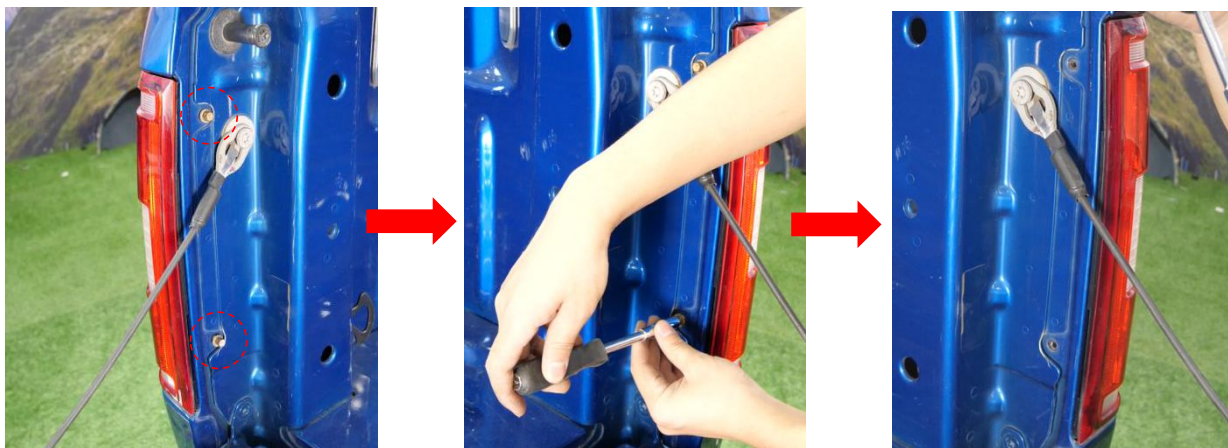

Pull these taillights out by plastic trim tool.

Tips: Please don't puss too hard, they're very prone to breaking the tabs in the back

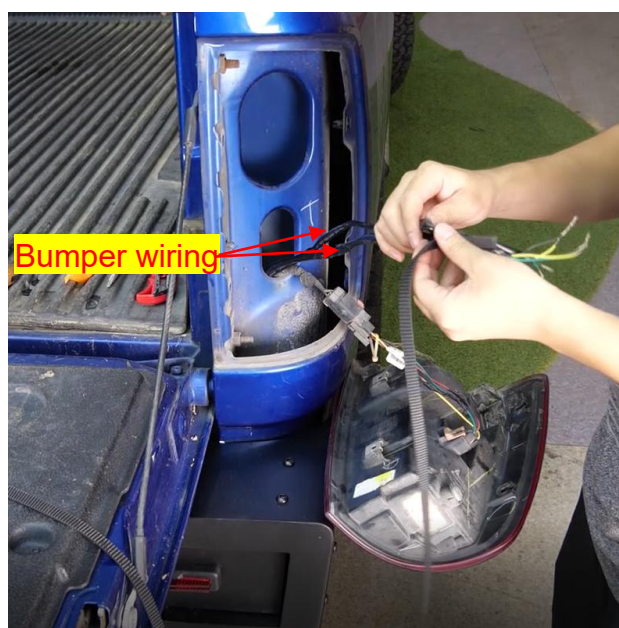
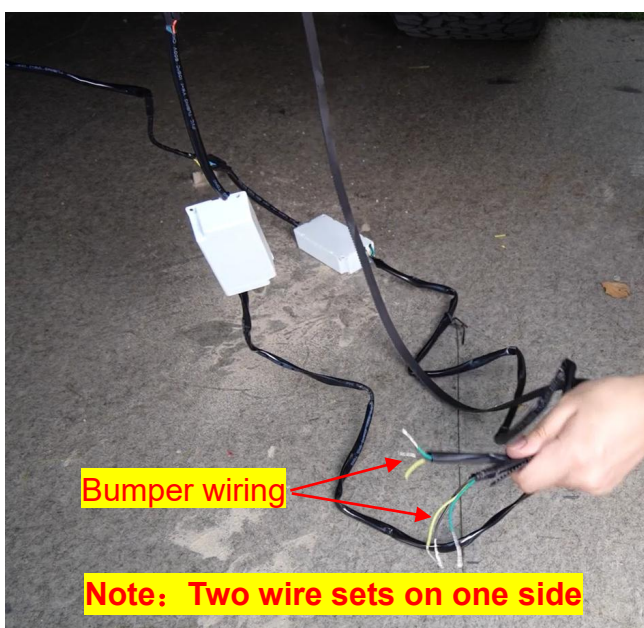

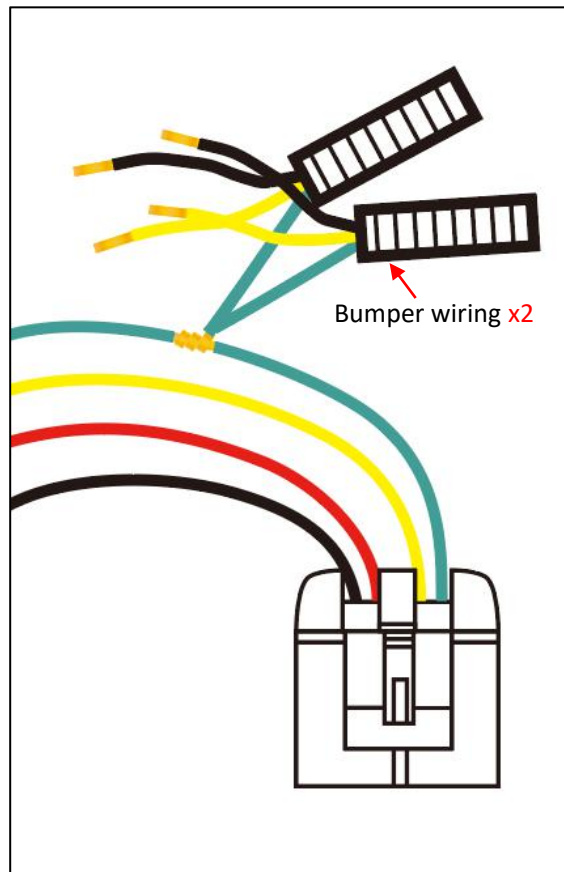
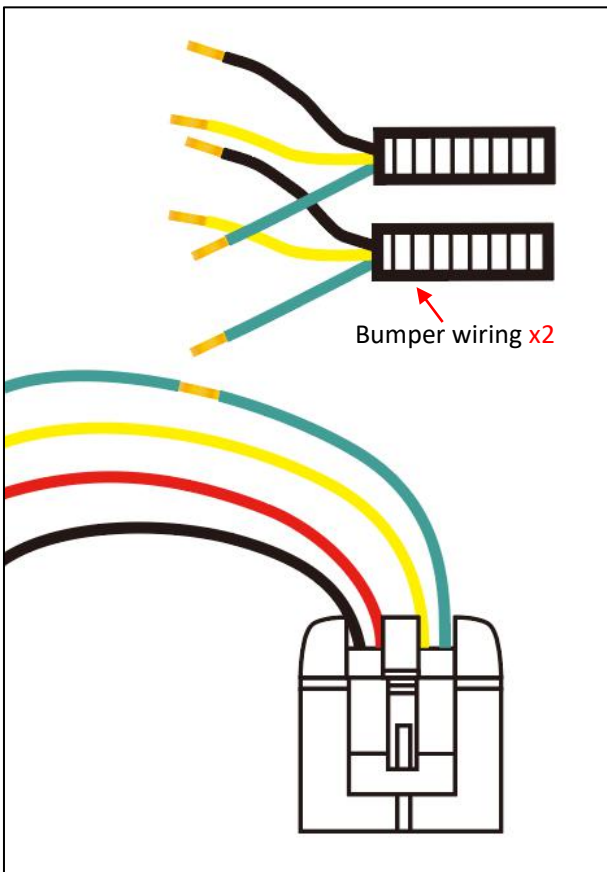
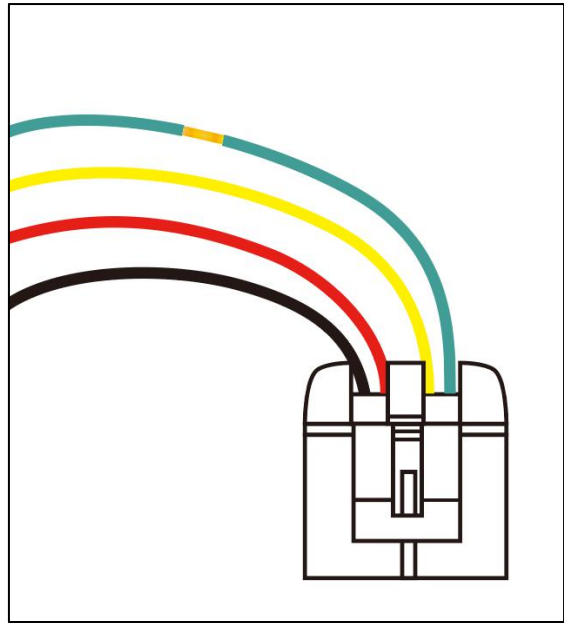
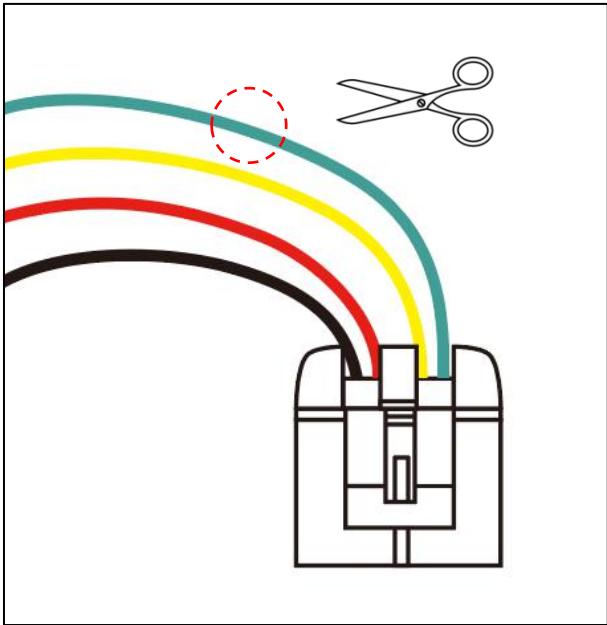

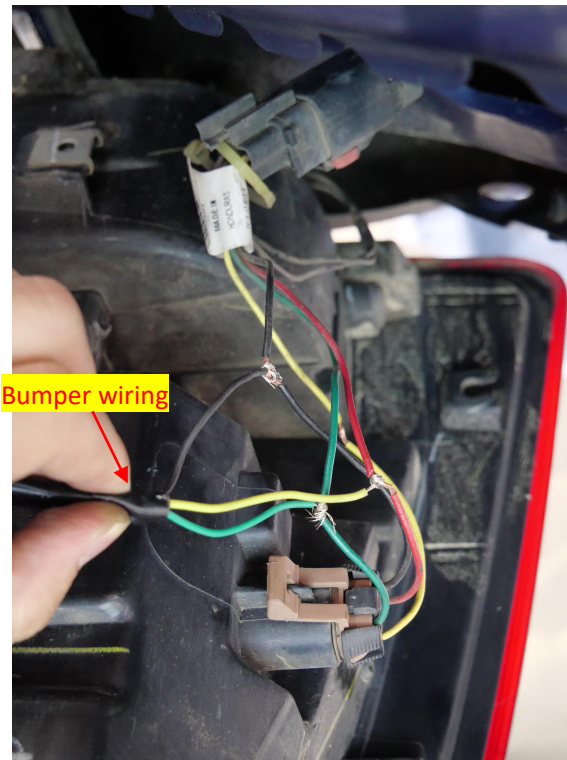
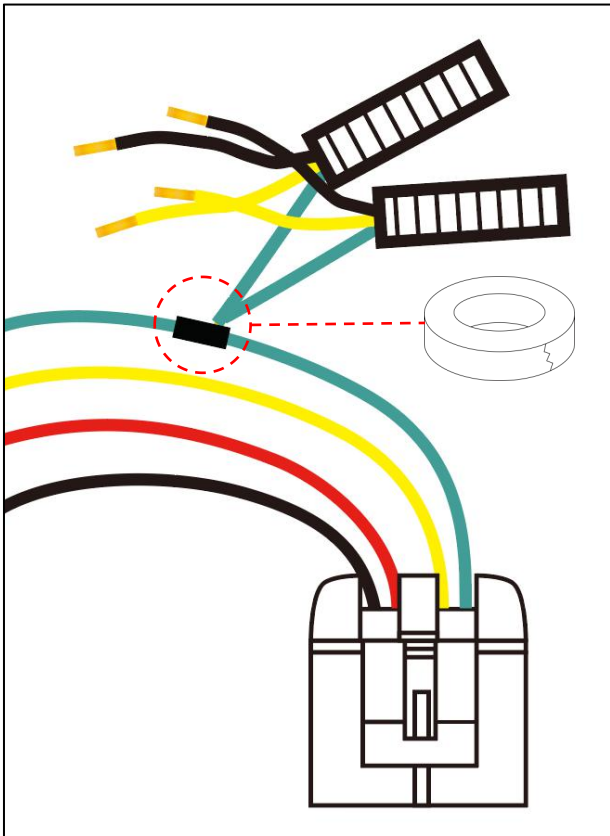

Step 8: Connect the license light wiring.

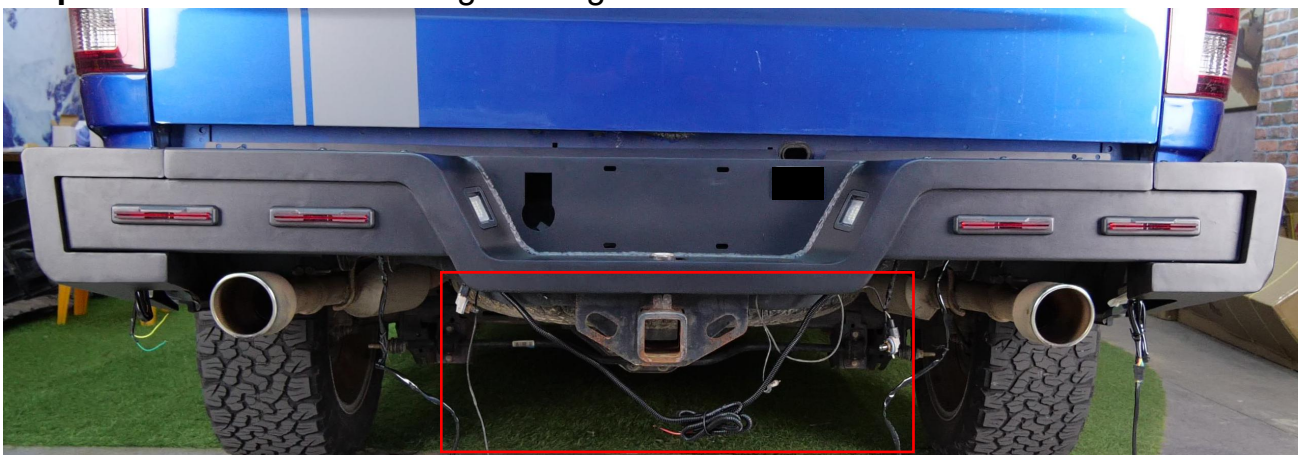

Step 9: Insert the trailer power.



Step 10: Bundling wires.

Step 11: Installation of the Rear Bumper is complete. Please do periodic inspections of the Rear Bumper to make sure that all hardware is secure and tight.