

SIDE STEP

————— User Manual —————

2019-2023 Jeep Gladiator 4 Door



Model:	NJT02C102
Material:	Q235A
Product Dimensions:	78.9 x 5.9 x 2.2 inch
Package Dimensions:	82.3 x 9.4 x 7.9 inch
Product Weight:	61.95 lbs

※ Thank you for purchasing the SIDE STEP. Please read this manual carefully and keep it properly if you need to refer to it afterward. If you need any support or assistance, please contact us with your product model number and order number, and our support team will help you solve problems.

⚠ WARNING





※ This product is designed primarily to enhance the appearance of the vehicle. Do not rely in any way on the components of this product to protect against injury or death in the event of an accident. To reduce the risk of serious injury or property damage, please read all safety messages and understand all instructions and procedure notices before attempting to install or use this product.

⚠ CAUTION







※ Properly torque and recheck fasteners and security of step tread after 250 miles and inspect frequently. Do not use if damaged.

※ Side Steps are heavy, and we strongly suggest the assistance of an able-bodied assistant during the lifting and installation of your Side Step.

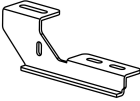
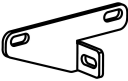
REQUIRED TOOLS

<p>Socket</p> 	<p>Ratchet</p> 	<p>Wrench</p> 	<p>Safety Glasses</p> 
---	--	--	---

Parts Information

Parts NO.	Parts Name	Size	Line Graph	Qty	Color
/	Side Step	/		2	Black
/	Left/Right Bracket	/		6	Black
/	Left/Right Support Bracket 1	/		4	Black
/	Left/Right Support Bracket 2	/		2	Black
B20	Hex Bolts	M8x25-8.8		26	Dacro Black
W16	Spring Washer	Φ8		38	Dacro Black
W19	Flat Washer	Φ8x24x2		38	Dacro Black
N14	Hex Nuts	M8		32	Dacro Black

***Note: spare parts such as B20, W16, W19, N14 are provided with 2PCS each (included in the number of parts details).**

Installation Instructions

※**Note:** This installation manual takes a single side as a sample, please repeat the steps for the other side.

Step 1: Open the carton and take out the parts. Check whether the number of components is complete.

Step 2: Install the bracket and support bracket.

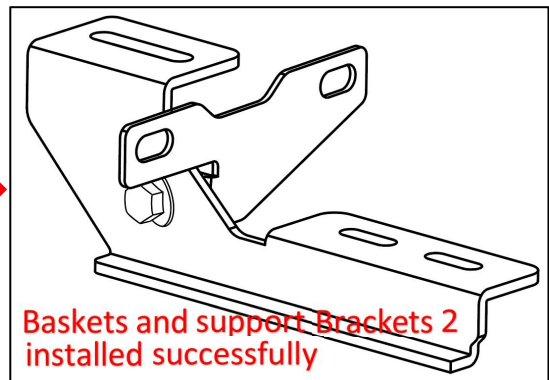
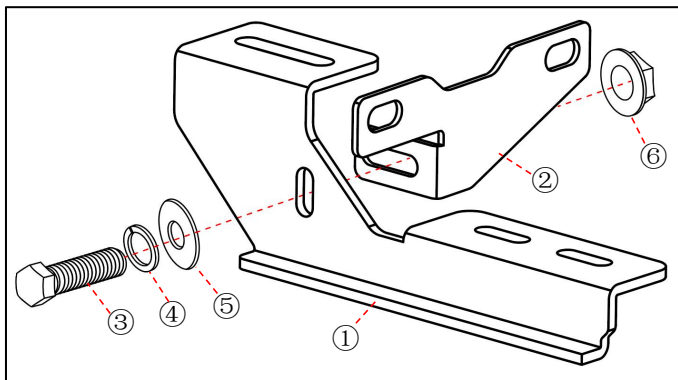
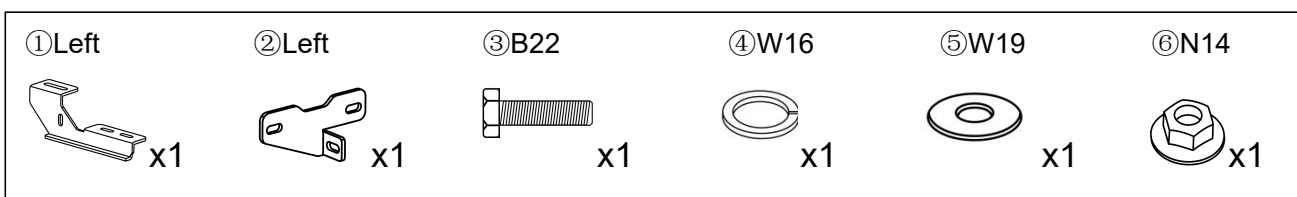
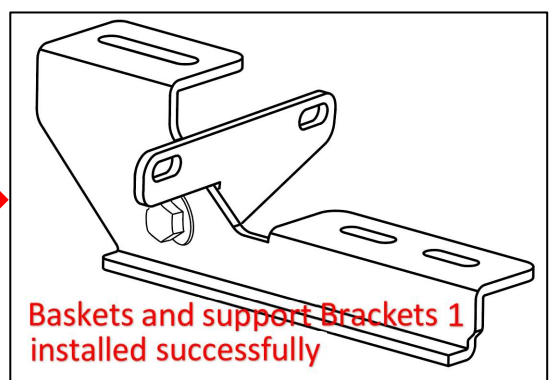
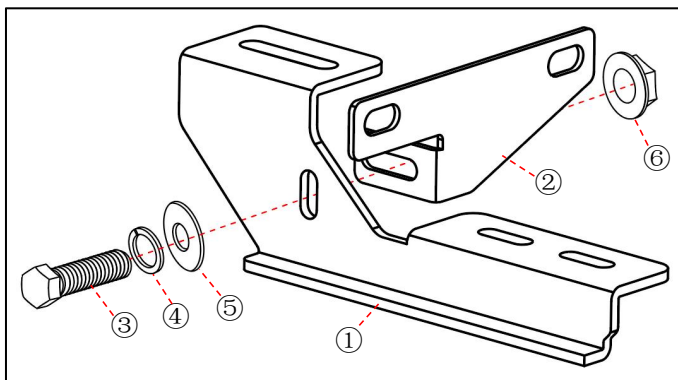
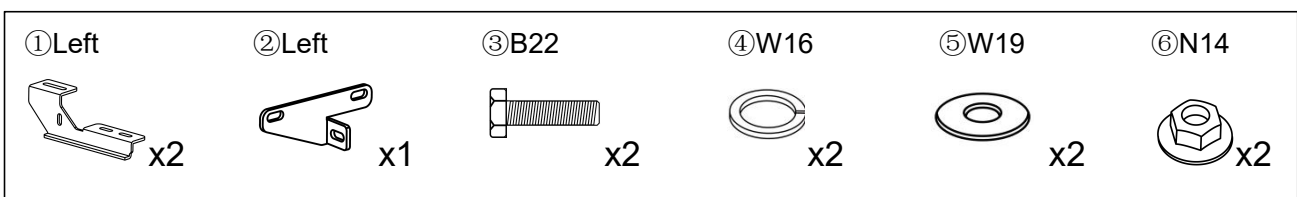

Step 3: Remove the original side skirt and clean the surface of the rocker panel to ensure it is free of dust, dirt, and debris.



Front of the car

Step 4: Install the brackets.

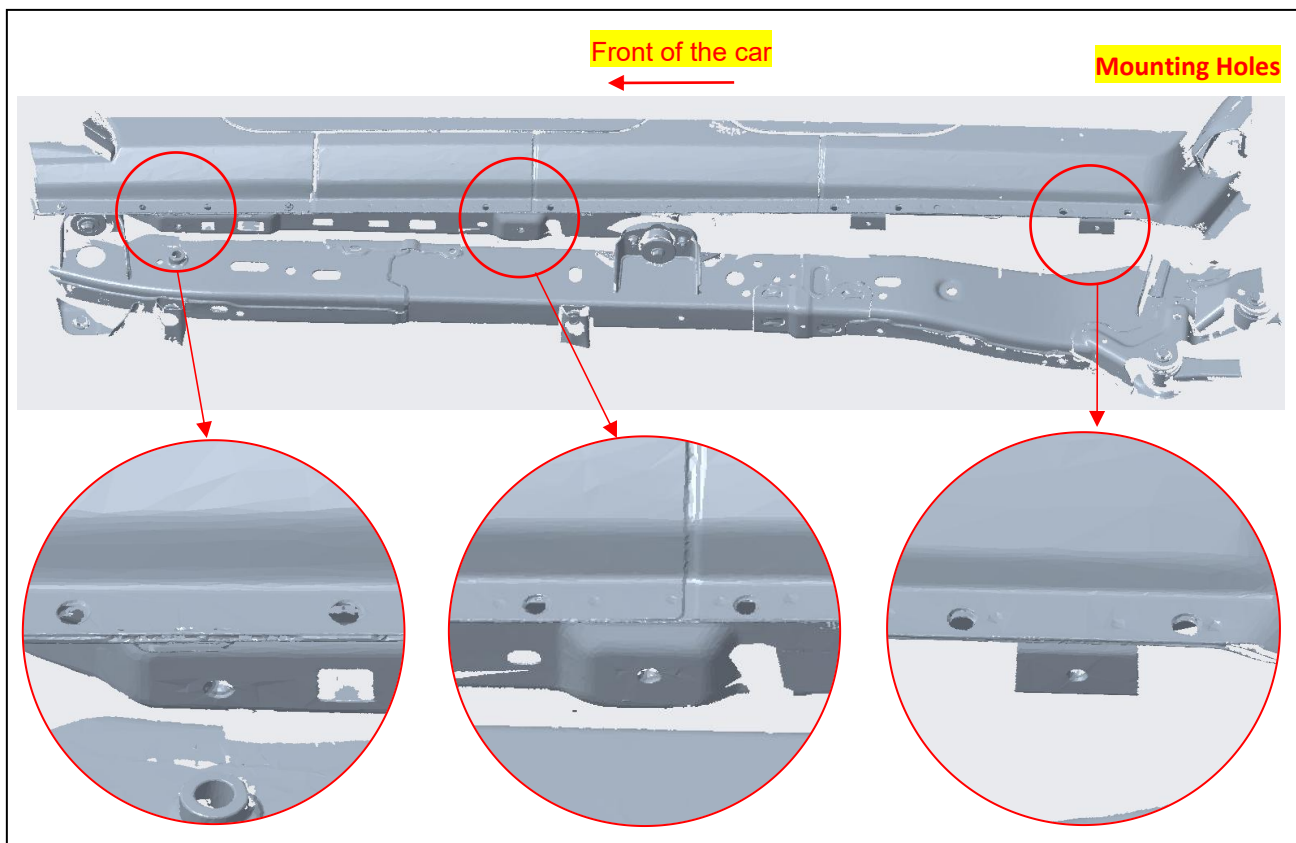
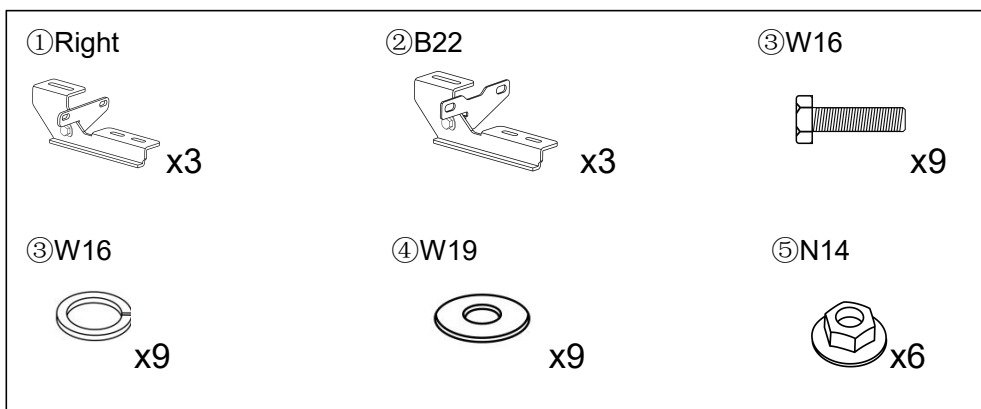

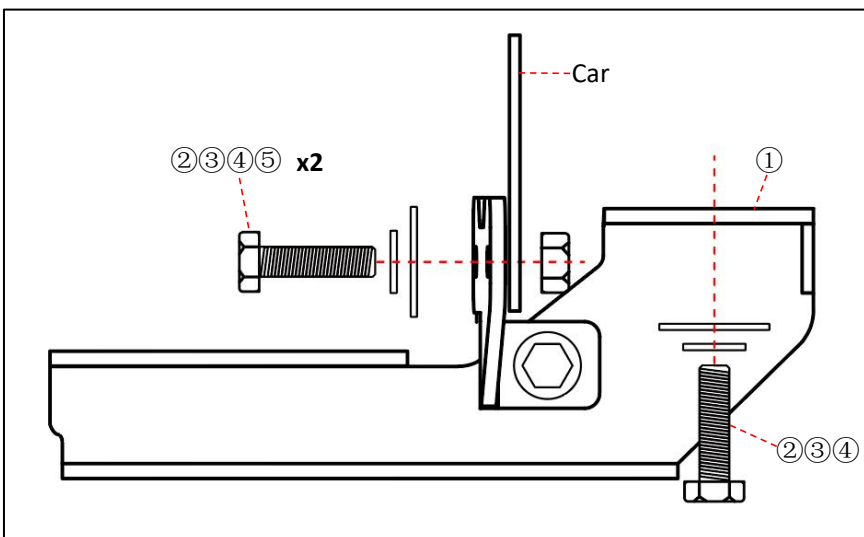
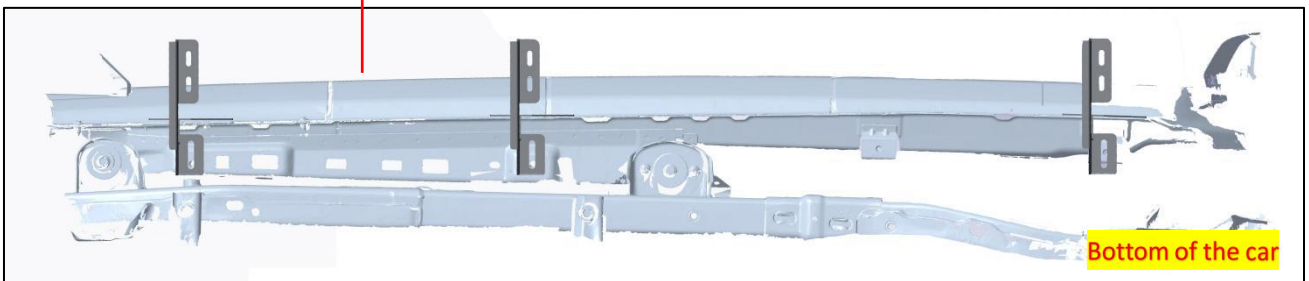
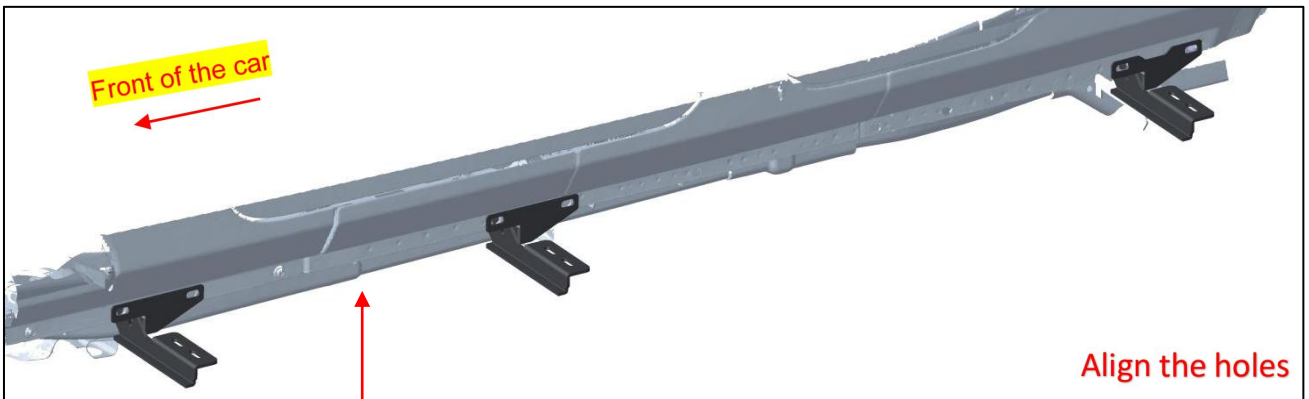
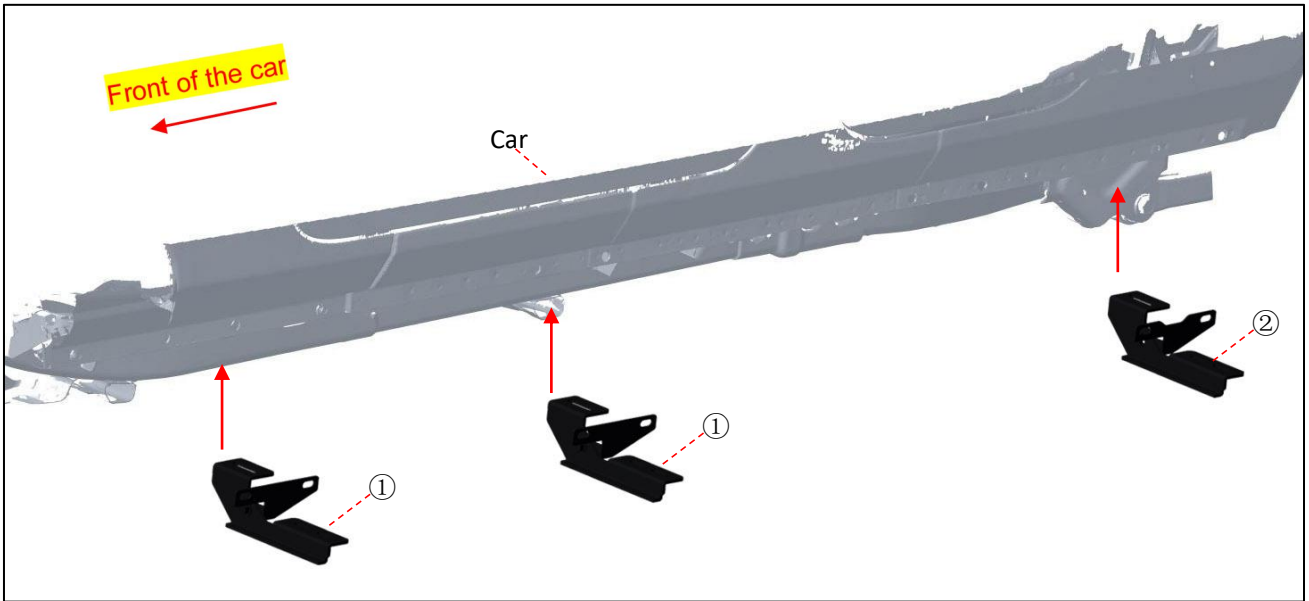

Step 5: Install the Side Step.

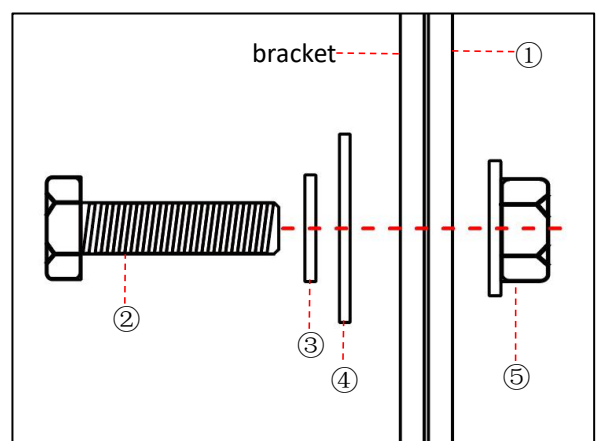
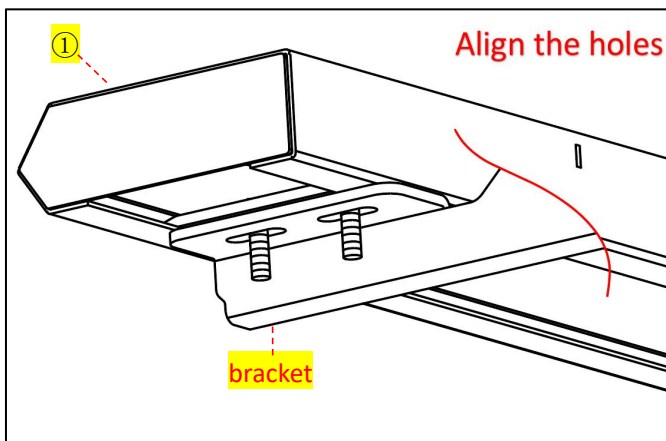
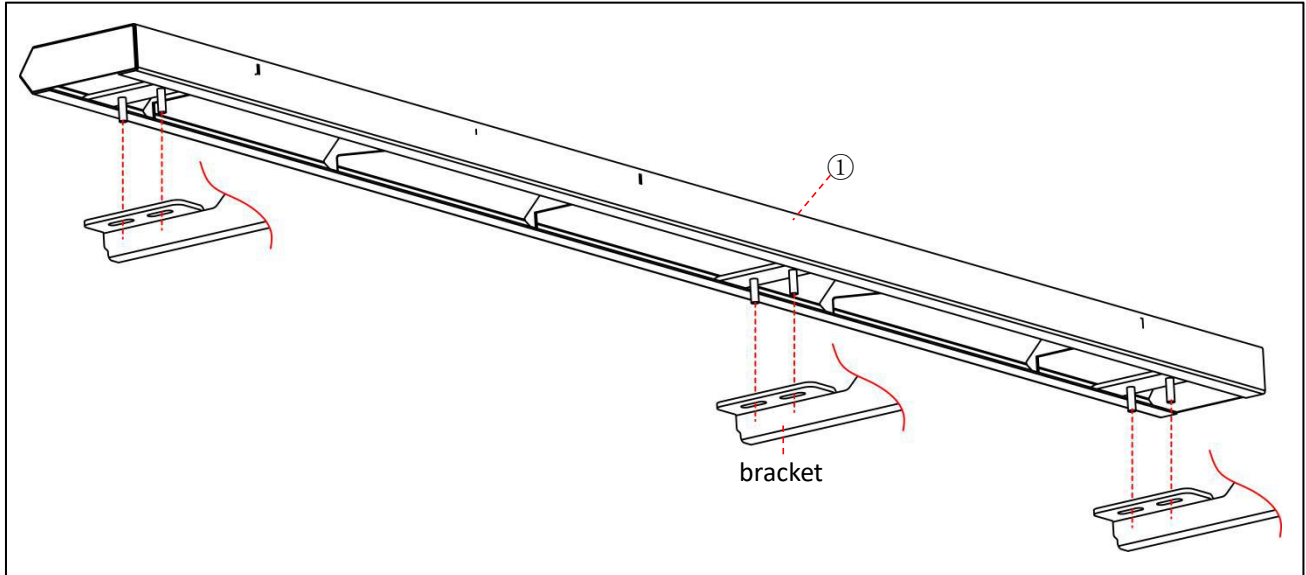
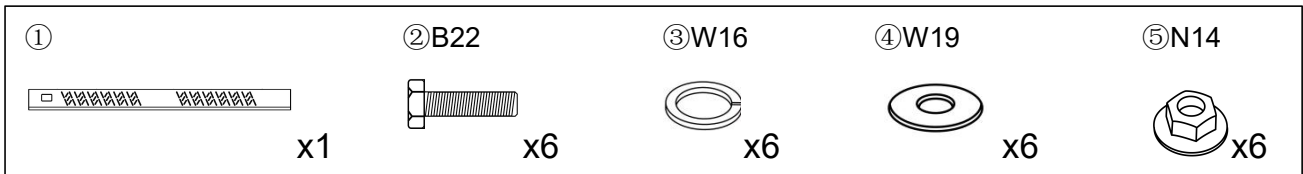

Step 6: Adjust the balance of the Side Step and the car side, and tighten the corresponding bolts.

Step 7: Adjust the balance of the pedal to the ground and tighten the corresponding bolts.

Tips: Use a stretch ruler to measure and balance the left and right sides of the pedal. Please ensure that the pedal has the same distance to the ground on both sides.

Step 9: Installation of a Side Step is complete. Please do periodic inspections of the Side Step to make sure that all hardware is secure and tight.